

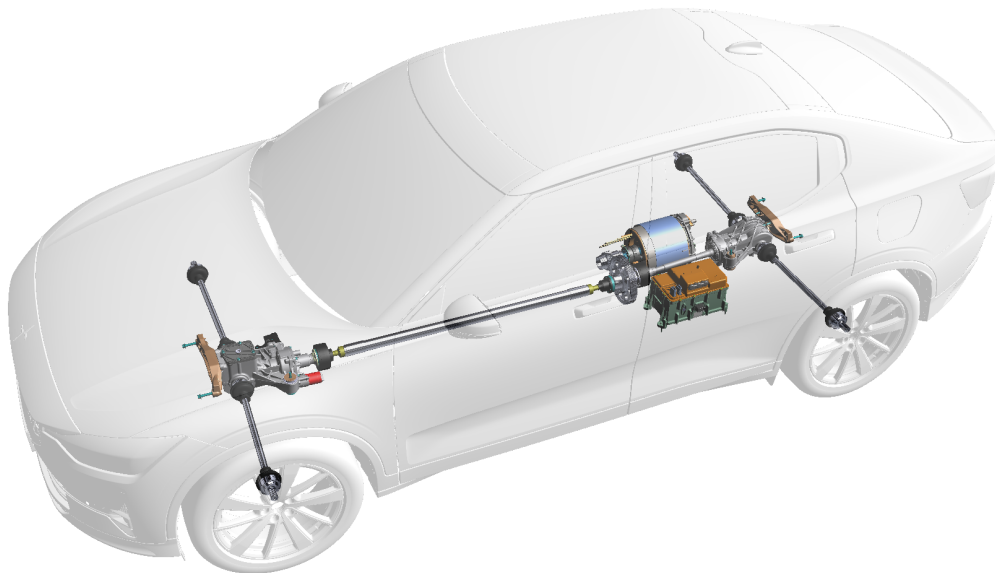

CHALMERS
UNIVERSITY OF TECHNOLOGY



Development of an alternative electric propulsion layout

Dimensioning of the electric propulsion layout and comparison with Polestar 2

Master's Thesis in Product Development

MARIA OTTOSSON NORDIN

ANNA RYDIN

MASTER'S THESIS 2019

Development of an alternative electric propulsion layout

Dimensioning of the electric propulsion layout and comparison with Polestar 2

MARIA OTTOSSON NORDIN

ANNA RYDIN



CHALMERS
UNIVERSITY OF TECHNOLOGY

Department of Industrial and Materials Science
CHALMERS UNIVERSITY OF TECHNOLOGY
Gothenburg, Sweden 2019

Development of an alternative electric propulsion layout

Dimensioning of the electric propulsion layout and comparison with Polestar 2

© Maria Ottosson Nordin and Anna Rydin, 2019.

Supervisor: Lars Stenvall, Volvo Car Group (VCG), Polestar

Supervisor: Johan Malmqvist, Chalmers University of Technology

Examiner: Johan Malmqvist, Department of Industrial and Materials Science (IMS)

Master's Thesis 2019

Department of Industrial and Materials Science (IMS)

Chalmers University of Technology

Chalmersplatsen 4, SE-412 96 Gothenburg

Telephone +46 31 772 1000

Cover: CAD-model. Credit: Lars Stenvall.

Typeset in L^AT_EX

Printed by Reproservice

Gothenburg, Sweden 2019

Abstract

One of the challenges of the automotive industry is the transformation from combustion vehicles to electric propulsion, through optimisation of the vehicle architecture for batteries and electric machines to develop the cars of tomorrow. Today's car OEMs within the premium segment seem all to follow the same trend; to increase the number of electric machines when increasing car performance. In collaboration with Volvo Car Group, this Master's Thesis has been conducted to dimension and compare an alternative electric propulsion layout utilising one electric machine in combination with a conventional AWD system, with the industry standard layout represented by Polestar 2. The two layouts have been compared regarding acceleration capacity and range, followed by a cost and weight analysis.

Initially an extensive literature study was carried out to understand the basic theory behind important components of the battery electric propulsion layout. Subsequently, a technology analysis was conducted including a competitor benchmark resulting in the identification of the industry standard propulsion layout for premium battery electric vehicles. Polestar 2 was confirmed to be a suitable representation of the industry standard.

The alternative propulsion layout was dimensioned by the means of Matlab simulations, focusing on the electric machine, which resulted in a similar performance in terms of range and acceleration compared to Polestar 2. Comparing the cost and weight of the systems resulted in a 4% decrease in cost and a 3% decrease in weight with the alternative propulsion layout. Thus, the new propulsion layout was concluded to be a cost and weight efficient alternative to the industry standard layout.

Keywords: *BEV, electric, propulsion*



Acknowledgements

And so the day was here. Five years at Chalmers University of Technology are wrapped up and finalised with the Master's Thesis. We are grateful to have been given the opportunity to write our Thesis at Volvo Cars and Polestar. It has been a challenging and fun experience where we have learnt a lot. Viewing the findings we have at hand we can humbly conclude that this work would not have been accomplished without the expertise and support from other people. We would like to send our warmest thanks to everyone who has been contributing to this project.

Some people have had extra involvement and importance for this Master's Thesis. Lars Stenvall, not only have you been the creator of the conceptual idea behind the whole project but you have also taken your time to support and help us in any possible way. Always with an optimism and interest we have never seen before. We could not have asked for a better supervisor. Tomas Åhlen, we are grateful for having been welcomed to your group.

Professor Johan Malmqvist, our examiner and supervisor, your feedback has both helped us to improve our report and opened up our eyes for how to visualise results in an intuitive way. Your guidance have helped us to keep on track all the way.

Bengt Noren, your help with navigation in the jungle of calculation methods has meant a great deal to us. The combination of valuable information and fun has been unbeatable. Professor Torbjörn Thiringer, your expertise in electric machines and inverters along with your helpful spirit have been invaluable for us and the project. You have been a true inspiration source for us when it comes to electrification. Viktor Briggner, Kim Bergsro and Mathias Jörgensson, your helpfulness and patience with all our questions have been very much appreciated.

Sara Miric-Smojver, we are impressed by your work as our opponent. You managed to give us valuable feedback of how to improve our report as well as encourage us and highlight good aspects. Lucile Boulainghier, Luisa Zlatoidska and Robin Söderblom, your support and enthusiasm has been important for us.

Thank you!

Elvorna Gothenburg, 2019-06-12

I will take this opportunity to thank my Master's thesis partner Maria Ottosson Nordin. I am so happy to have done this project with you. Apart from always giving your all (which is a lot and more than one can ask for) for the project you are a wonderful friend who supports when needed. Together we have fought with the project, celebrated important milestones and have made this spring a great time. We should be proud of what we have accomplished. I wish you all the best in future!

To my family, thank you from the bottom of my heart for your unconditional love. You are nothing but the best! Karl, your support means the world to me.

Thank you!

Anna

I would like to dedicate a massive thank you to Anna Rydin, my amazing partner in this Master's Thesis. I remember when we worked together for the first time at Chalmers, where I gained a talented colleague, but above all a really good friend. With your drive and passion you have inspired me since day one. Through the ups and downs, I have had so much fun doing this Master's Thesis together with you! And I agree, we should be proud of what we have accomplished. All the best wishes in your future adventures. From one "Elva" to another, thank you!

I would also like to express my deepest gratitude to my family and my boyfriend Viktor for their endless support. I love you!

Thank you!

Maria

Acronyms

4WD Four-Wheel Drive. 13

AC Alternating Current. 6

AD Autonomous Drive. 2

ADAS Advanced Driver Assistance Systems. 2

AFM Axial Flux Machine. 10

AWD All-Wheel Drive. 5

BEV Battery Electric Vehicle. 1

CEO Chief Executive Officer. 28

DC Direct Current. 6

EFAD Electric Front Axle Drive. 7

ERAD Electric Rear Axle Drive. 7

EU European Union. 1

EV Electric Vehicle. 1

FDU Front Drive Unit. 36

FTO Freedom To Operate. 18

FWD Front-Wheel Drive. 14

HEV	Hybrid Electric Vehicle.	1
ICE	Internal Combustion Engine.	1
Li-Ion	Lithium-ion batteries.	15
NEDC	New European Driving Cycle.	6
NVH	Noise, Vibration, and Harshness.	30
OEM	Original Equipment Manufacturer.	1
PHEV	Plug-in Hybrid Electric Vehicle.	2
PM	Permanent Magnets.	9
R&D	Research and Development.	21
RDU	Rear Drive Unit.	36
RFM	Radial Flux Machine.	10
RMF	Rotating Magnetic Field.	9
rpm	revolutions per minute.	43
RWD	Rear-Wheel Drive.	15
SUV	Sport Utility Vehicle.	2
TRL	Technology Readiness Level.	15
VCG	Volvo Car Group.	2
WLTC	Worldwide Harmonised Light-duty Vehicle Test Cycle.	37
WLTP	Worldwide Harmonised Light-duty Vehicle Test Procedure.	6

Contents

Abstract	v
Acknowledgements	viii
Acronyms	x
List of Figures	xiii
List of Tables	xv
1 Introduction	1
1.1 Background	1
1.2 Volvo Car Group	2
1.3 Project background	2
1.4 Scope and Delimitations	3
1.5 Goals and Deliverables	3
1.6 Report Structure	4
2 Theoretical Framework	5
2.1 Electric Vehicles	5
2.2 BEV Propulsion System	6
2.3 Components and their Function	7
2.3.1 Electric Machine	8
2.3.2 Inverter	11
2.3.3 Transmission Elements	12
2.3.4 Disconnect Clutch	14
2.3.5 Battery Pack	15
3 Methodology	17
3.1 Literature Study	17
3.2 Technology Analysis	18
3.3 Preliminary Design	19
3.4 Final Evaluation	19
4 Technology Analysis	21
4.1 Current BEV Environment	21

4.1.1	Benchmark	21
4.1.2	Polestar 2 Comparison	25
4.1.3	Patent Search	27
4.1.4	Summary of the Current BEV Environment	27
4.2	Polestar 2	28
4.3	Polestar 2 Propulsion Layout	29
4.3.1	Electric Machine, Inverter and Transmission	29
4.3.2	Battery Pack	30
4.4	Technical Specifications	30
5	Preliminary Design	33
5.1	Concept Description	33
5.2	Technical Requirements	33
5.3	Alternative Propulsion Layout	34
5.3.1	Components	34
5.3.2	Positioning and Placement	36
5.4	Dimensioning	37
5.4.1	Machine	38
5.4.2	Range	40
5.4.3	Acceleration	41
5.5	Cost and Weight Estimations	43
5.5.1	Cost Estimation	43
5.5.2	Weight Estimation	44
5.6	Sensitivity Analysis	44
6	Final Evaluation	45
6.1	11:an Propulsion Layout	45
6.2	Comparison with Polestar 2	46
6.2.1	Architectural Design	46
6.2.2	Performance Requirement Fulfilment	47
6.2.3	Cost and Weight Analysis	47
7	Discussion	51
7.1	Alternative Propulsion Layout	51
7.2	Goal Fulfilment	52
7.3	Validity	53
7.4	Reflection on Sustainability	54
8	Conclusions and Recommendations	57
8.1	Conclusions	57
8.2	Recommendations and Future Work	58
	References	59

List of Figures

1	BEV Propulsion System. Flow chart showing the propulsion system of a BEV. [Own illustration].	7
2	Conventional BEV System Chart. Tree chart illustrating the hierarchy of the BEV propulsion system, including EFAD and ERAD subsystems. [Own illustration].	8
3	Stator and Rotor. Illustration of the rotor rotating inside the stationary stator. [Own illustration].	9
4	RMF Illustration. Two RMFs, one on the stator and one on the rotor, as a result of the attraction and repulsion of stator- and rotor- poles. [Own illustration].	9
5	Rotor Comparison. The different rotor structures of the PM - and induction - machines.[Own illustration].	10
6	RFM and AFM Comparison. Own illustration of the structure and directional flux flow of the different machine categories, inspired by the graphic illustrations on the Magnax website.	11
7	Inverter Relative Size. Own photograph illustrating the size of an inverter from a current HEV in relation to a pen.	12
8	Inverter Cabling. Own illustration of how the inverter is connected to the machine and battery respectively, converting DC to AC.	12
9	Transmission Components. Illustrations of a bevel- and planetary-gear, which are commonly used transmission elements in BEV- and non-BEV- AWD-systems. Pictures retrieved from Wikipedia.	14
10	Standard Open Differential. Illustration of the structure of a standard open differential, acquired from Wikimedia Commons.	14
11	Methodology. Presenting the process steps that has been followed to conduct this project. [Own illustration].	17
12	Benchmark Segment Representatives. From the left: BMW i3s Comfort Edition, Tesla Model 3 Long Range and Mercedes-Benz EQC 400 4MATIC.	22
13	Medium/Large/Executive Cars. Comparative study of Polestar 2 and its competitors within the corresponding car segment. [Own illustration].	26
14	Polestar 2. Side view of Polestar 2, acquired from Polestar’s website.	28

15	Polestar 2 Propulsion Layout. Top view and side view of the Polestar 2 propulsion layout, acquired from Polestar’s website. The car front is to the left.	29
16	The profile of WLTC. It is represented as a graph describing the velocity as a function of time. The total cycle duration is 1800s and reaches a maximum velocity of 131.3 km/h. [Own graph].	37
17	Alternative Machine Dimensions. Presenting the generated machine specifications and dimensions. [Own figure].	39
18	Final Architectural Design. The final architectural design of the alternative propulsion layout. Modelled by Lars Stenvall.	45
19	Propulsion Layout Comparison. The propulsion system layout of Polestar 2 and 11:an in comparison. The top of the picture represents the rear of the car. Modelled by Lars Stenvall.	46
20	Component Cost Comparison with Polestar 2. Graph showing the cost of the components of 11:an in relation to the corresponding components in the layout of Polestar 2. [Own Illustration].	49
21	Component Weight Comparison with Polestar 2. Graph showing the weight of the components of 11:an in relation to the corresponding components in the layout of Polestar 2. [Own Illustration].	49
22	Cost Walk of 11:an. Graph showing the cost walk of 11:an comparing the component cost in relation to the overall layout of Polestar 2. [Own illustration].	50
23	Weight Distribution of 11:an. Graph showing the weight distribution of 11:an comparing the component cost in relation to the overall layout of Polestar 2. [Own illustration].	50

List of Tables

1	General Benchmark Data. In the left column, car brands are listed followed by corresponding car model. Their acceleration, range, weight, and price are given in the following columns.	24
2	Motor Specific Data. In the left column, car brands are listed following by corresponding car models. Subsequent columns present the number of, type and position of, and drive type of the machine(s) utilised in each car model.	25
4	Polestar 2 dimensions. In the left column the length of the car is presented, followed by the height of-, the width of- (including mirrors) and the wheelbase measurements.	30
3	Polestar 2 data. In the left column the components and subsystems are stated, followed by their weight and cost. X and Y denotes the total cost and weight of the system respectively. X_1 and Y_1 is the cost and weight of EFAD, while X_2 and Y_2 is the cost and weight of ERAD. Moreover the properties of the components and subsystems are presented.	31
5	Technical Requirements. In the left column the criteria is presented, followed by the target value and the level of requirement. Then the weight of the desired criteria is presented along with verification method and specifier. $t_{a,PS2}$ represents the acceleration capacity of Polestar 2 and D_{PS2} its range. X represents the total propulsion cost of Polestar 2, and Y represents its total weight.	35
6	Cost Results. Showing the cost of the alternative propulsion layout expressed as a proportion of the cost of the propulsion layout of Polestar 2. X representing the total cost, x_1 the cost of the machines, x_2 the cost of the inverters, x_3 the transmission cost and x_4 the cost of the battery pack.	47
7	Weight Results. Showing the weight of the alternative propulsion layout expressed as a proportion of the weight of the propulsion layout of Polestar 2. Y representing the total weight, y_1 the weight of the machines, y_2 the weight of the inverters, y_3 the transmission weight and y_4 the weight of the battery pack.	48

1

Introduction

To understand the foundation of the project presented within this report, this chapter aims at introducing the reader to the company- and project background, along with the purpose of execution. Moreover, the scope and necessary delimitations are presented, followed by goals and key deliverables. Finally, the report structure is summarised.

1.1 Background

The World is presently facing enormous challenges regarding environmental issues. The global warming is a hot topic discussed all around the globe in several contexts, political as well as others. To stop the ongoing increase of the global temperature a number of actions have been discussed and taken, many of them regarding CO₂ and other greenhouse gas emissions. According to the European Commission around 12 % of the CO₂ emissions in the European Union (EU) come from cars. To reduce the emission levels in EU a new target will be implemented stating that "by 2021 the fleet average to be achieved by all new cars is 95 grams of CO₂ per kilometre" [1]. Every automotive Original Equipment Manufacturer (OEM) exceeding the target will be penalised with payment for every g/km above the target.

Another problem being discussed is air pollution, specially in big cities having problems with high amounts of harmful particles in the air. Now some cities and countries have indicated that they will ban Internal Combustion Engine (ICE) vehicles in the coming years or decades [2]. A pattern seen in many claims is to first introduce a diesel restriction and then to follow up and ban all ICE cars.

The environmental aspects as well as the legislation around cars, are two strong drivers for the automotive industry to develop technology for more sustainable means of transportation. The introduction of the Electric Vehicle (EV) has been a usual strategy among the car manufacturers and as a first step essentially all big OEMs have launched at least one kind of Hybrid Electric Vehicle (HEV), providing synergistic use of the two power sources of the ICE and an electric machine. The next step seem to be the Battery Electric Vehicle (BEV), also called Fully Electric Vehicle, as there today have been many announcements of BEVs coming in the near future.

While the electrification work is fully going on at some OEMs, others have different strategies. E.g. Toyota has confirmed that they are not planning to launch any

BEV, instead they are focusing on, what they believe will be the next technology phase, hydrogen fuel cell cars [3]. Nevertheless, a lot is happening within the area of BEVs at the moment and most OEMs seem to take part of the race during this technology change.

Apart from the car industry, the electrification of other vehicles such as trucks and buses is well under way [4]. A local example from Gothenburg is ElectriCity, a joint venture that is operating electric buses [5]. Progress is also seen in the electric boat and aircraft industries [6], [7].

1.2 Volvo Car Group

This Master's Thesis has been performed in collaboration with Volvo Car Group (VCG), a car manufacturer within the premium segment offering models of sedan, station wagon, and Sport Utility Vehicle (SUV) types. VCG is to put one million EVs on the road by 2025. Both BEV and Plug-in Hybrid Electric Vehicle (PHEV) models will play a role in this commitment [8].

The company was founded by Assar Gabrielsson och Gustaf Larson as a subsidiary of the rolling-element bearing manufacturer AB SKF (Svenska Kullagerfabriken) in Gothenburg, Sweden. The name Volvo derives from the Latin "I roll" [9]. In 1927 the factory in Torslanda was opened and the first mass produced Volvo entered the roads. Volvo Cars was a part of AB Volvo until 1999, when it was sold to Ford Motor Company [10]. In 2010 Volvo Cars was bought by the current owner Zhejiang Geely holding (Geely Holding) [11].

Today VCG consists of Volvo Cars and five other businesses, all related to Volvo Cars. Polestar is an electric performance car brand, Care by Volvo offers a car subscription service as an alternative to owning or leasing a Volvo car, Zenuity are building Advanced Driver Assistance Systems (ADAS) and Autonomous Drive (AD) systems, M is a mobility company developing an on-demand service for cars, and Lynk & Co is a Chinese car brand [12], [13], [14], [15], [16], [17].

1.3 Project background

Today the automotive industry is facing great challenges. One of them is the transformation from combustion to electric propulsion, e.g. optimising the vehicle architecture for batteries and electric machines to develop the cars of tomorrow. The electrification of cars was initiated over 100 years ago. Electric cars then competed with combustion cars for market share until the beginning of the 20th century, when combustion cars took over the market as they became more affordable and accessible compared to the electric car [18]. This caused the development of electric cars to halt. However, due to e.g. environmental aspects, the interest in and development of electric cars has accelerated in recent decades.

In order to be competitive in the market, efficient electric propulsion layouts need to be in place. This is where the Master's Thesis will contribute. Today's car OEMs within the premium segment seem all to follow the same trend; to increase the number of electric machines when increasing performance (acceleration capacity and top speed). In addition, transmission elements and an inverter is needed for each machine. By investigating an alternative propulsion layout with one machine only, the aim is to reduce the weight and/or cost of the system, two important parameters in the automotive industry that always are desired to be minimised. Components included in the system investigated are the electric machine, inverter, and transmission. However the result will affect other systems, like the battery pack.

1.4 Scope and Delimitations

This project investigates a given alternative propulsion system solution and dimensions its including components. Further, with equivalent performance in terms of range and acceleration, the weight and cost is compared with the industry typical layout, represented by a reference BEV, Polestar 2. The alternative system layout will be built on increased integration of functions which might contribute to a lower weight. Also, the project aims in answering why the typical performance layout includes at least two machines.

In order to focus the scope of the project, relevant delimitations associated with the thesis work are set and presented below.

- The initial concept layout, referring to an electric propulsion system for a car model, will be provided by the company supervisor.
- The components included in the system to be compared are the machine, inverter, and transmission. Other systems, such as the battery pack, will be outside the scope for this project.
- The dimensioned alternative electric propulsion layout will only be compared to Polestar 2.
- The Master's Thesis is not expected to investigate if the alternative solution is possible to be produced in the current factories.
- The project will be limited in time. Two master students will spend approximately 20 weeks, corresponding to 800 hours each. The project will run from January to June 2019.

1.5 Goals and Deliverables

The main goals identified for this project are summarised as follows.

- Performing a competitor benchmark describing the current standard propulsion layout within the BEV premium car segment.
- Mapping the current layout of Polestar 2, including crucial components and their function within the system.

- Proposing an alternative BEV propulsion layout, where components are dimensioned based on a given system solution. Further, investigating the efficiency of the proposed layout in terms of cost and weight.
- Comparing the efficiency of Polestar 2 with the proposed alternative layout regarding cost and weight, given the same capacity in terms of range and acceleration.
- Recommending actions to take regarding future development of the alternative BEV propulsion layout.

Based on the presented goals, important deliverables of the project have been identified. A summary of which is presented below.

- Planning report to structure the thesis work.
- Summary of a benchmark study in order to build knowledge on the industry standard layout and identify possible advantages and innovation potential.
- Summary of a pre-study in order to gather information on weight, cost, range and acceleration properties of the propulsion layout of Polestar 2.
- Geometrical layout of the alternative system solution, with included components dimensioned.
- Comparison of the alternative layout with the one of Polestar 2, in terms of weight and cost, range and acceleration properties.
- List of positive and negative aspects for the alternative layout with respect to Polestar 2.
- Conclusions based on facts and engineering judgement, whether or not the alternative propulsion layout is more efficient, in terms of cost and weight, compared to Polestar 2.
- Final Master's Thesis report.

1.6 Report Structure

The report starts with an *Introduction* of the study, presenting the background from a wide perspective of electrification in general followed by its presence within the car industry, narrowing it down to application at VCG and in detail within the study. In the next chapter the *Theoretical Framework* required to understand the context of EVs is presented, focusing on the architecture of BEVs. Subsequently, the *Methodology* process followed when conducting the project is described. The succeeding chapter presents the *Technology Analysis* that has been carried out including a benchmark study identifying the current BEV environment, an initial patent search and mapping of the reference car, Polestar 2. In the *Preliminary Design* chapter the alternative propulsion layout is presented and dimensioned, including positioning and placement of components. Moreover the *Final Evaluation* is presented in the following chapter, including a comparison with Polestar 2. The final two chapters include *Discussion* of the result and use of methodology, followed by *Conclusions* and *Recommendations* on further development.

2

Theoretical Framework

This chapter aims at providing the reader with a basic understanding of EVs today and more in detail how the components of a BEV propulsion system are laid out. Therefore, relevant theory is presented, starting with a general description of EVs followed by an overview of the BEV propulsion system, including the energy transfer between the components and how they work together to propel the vehicle. Moreover deeper theory on how the components work individually are described to indicate which are prioritised within this project and why. This theory includes non-BEV components and systems as well, such as transmission components used to achieve All-Wheel Drive (AWD), which are relevant to understand the alternative propulsion layout developed in Chapter 5. Further, some theory on the calculations and simulations that has been performed are discussed, to enrich the reader's comprehension of the dimensioning and evaluation of the alternative propulsion layout. Overall, the theory presented constitutes a knowledge base which facilitates a deeper understanding when further reading the report.

2.1 Electric Vehicles

An EV is more or less propelled by electricity. There are different types of EV's on the market today, including fully electric vehicles and different levels of hybrid solutions (HEVs and PHEVs). Hybrid solutions typically use electric machine(s) and an ICE to propel the vehicle, while the BEV is powered solely by electricity through the use of a battery pack [19]. Electric power accumulation in EVs allows for regenerative braking which enables efficient usage of the ICE in HEVs, lowering associated emissions. However, compared to a BEV the main source of power in a HEV is still the ICE [20],[21]. Plug-in EVs are mainly charged by connecting a plug to the electric power source, in addition kinetic energy can be regenerated through braking [22]. The focus of this project is the BEV.

In the ongoing race of electrification in the automotive industry there are some parameters of extra importance as they are used as measurement when the players are comparing one another. The parameters of highest priority are the ones that the customers are valuing in their analysis when choosing a car.

Driving range, henceforth denoted *range*, is a criterion of high concern for both the OEMs and the customers. Range anxiety [23] among potential buyers is one aspect

of it, which according to studies seems to be more commonly present among car owners not owning any BEV [24]. Essentially, the range can be described as the battery capacity minus losses, hence the battery capacity is the most important factor for the range. The losses are related to both vehicle design and driving style [25]. Parameters affecting the range are, e.g., the outside temperature, the usage of heating, air condition or other accessories in the car, the road profile, the speed, and the usage of the accelerator and brakes [26]. Further, the vehicle weight has an influence on the range [27]. Thus, comparing the specifications of two cars, the battery capacity in kWh does not give the full picture.

In order to make a fair range comparison between two BEVs it is important to use the same drive cycle. There are a number of drive cycles and different markets have different standards of which one to use. In EU all new cars, since September 2018, have to be certified according to the Worldwide Harmonised Light-duty Vehicle Test Procedure (WLTP) drive cycle [28]. WLTP is tougher than the previous EU standard New European Driving Cycle (NEDC), thus gives a shorter, more realistic, range [29].

Another important performance parameter is *acceleration*. The time to accelerate from 0 to 100 kmh can easily be compared between several car models. Whereas the range is a parameter discussed by more or less everybody, being a parameter of interest for all BEVs regardless of segment, the acceleration instead divides the models into different segments. For premium cars the acceleration is a factor considered by the consumers and is important for the feeling of a powerful car when driving.

In the automotive industry *weight* is a parameter to consider for every component in every project. Lighter vehicles are advantageous as they require less battery capacity, which in turn has a positive impact on the *cost* as the battery is a significant cost driver. In such a competitive market as the car industry the cost is super important as it has a great impact on the final price tag offered to the customers. Further, cost reduction is important for every company's economical sustainability.

2.2 BEV Propulsion System

The propulsion systems of EVs differ depending on the number and nature of their power source(s). In Figure 1 a schematic overview of the propulsion system of a BEV is presented. The battery pack transmits constant Direct Current (DC) to the inverter that converts it into Alternating Current (AC) that powers the electric motor. The electric motor then transforms the electric energy to mechanical energy through the transmission of torque. The rotation speed is then reduced by a set gear ratio transferring the torque onto the wheel axle. Moreover, energy recovery is possible through regenerative braking, which is further explained in Section 2.3.2.

A central part of the propulsion system is the electric machine, which mainly acts as a motor but periodically takes on the role of a generator, depending on the current

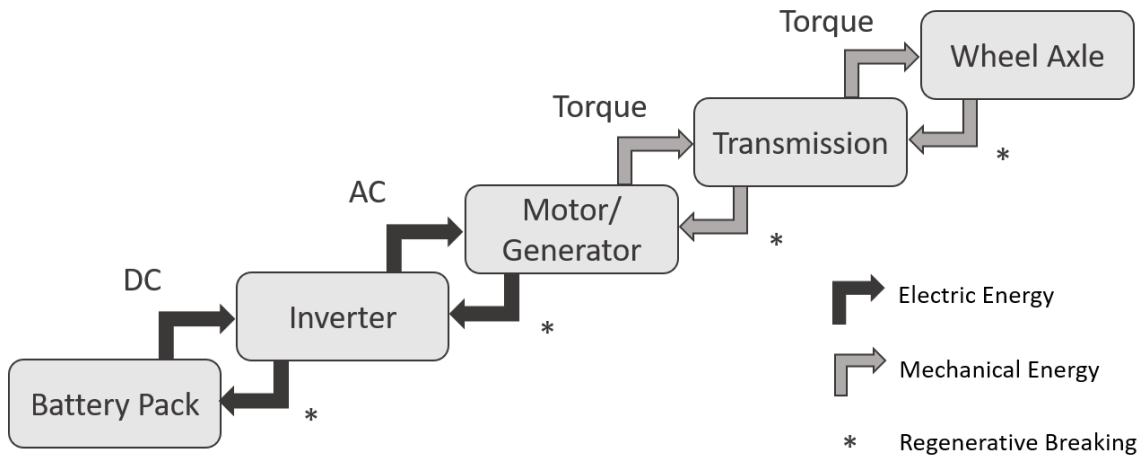

Figure 1: BEV Propulsion System. Flow chart showing the propulsion system of a BEV. [Own illustration].

driving mode. Further, the electric machine refers to motor/generator, while motor and generator refers to the different modes respectively.

BEVs can be front-, rear- or all-wheel driven, depending on the specifications of the vehicle. AWD systems are usually more expensive, because of the increased complexity of the propulsion system. Within electric drive, front- and rear wheel drive axles are denoted Electric Front Axle Drive (EFAD) and Electric Rear Axle Drive (ERAD) respectively. Depending on the propulsion architecture, EFAD and ERAD usually include the layout of the inverter, the electric machine and the transmission component.

The system boundary in this Master’s Thesis is covering EFAD and ERAD, according to Figure 2, including the inverter, machine, and transmission in both subsystems. As can be seen, the propulsion system contains other subsystems, such as the cooling system and battery pack. Those systems are all going to be more or less affected by the alternative layout, but to what extent will not be investigated here. In order to set the system to be compared into context Figure 1 can be helpful since it shows the subsystems to which the energy is flowing from and to.

2.3 Components and their Function

Within this section, theory behind some of the basic components of the BEV propulsion system is presented; the electric machine, transmission elements, disconnect clutch, inverter and battery pack. The summarised transmission theory also includes conventional AWD transmission components as they are relevant for understanding the alternative BEV propulsion layout.

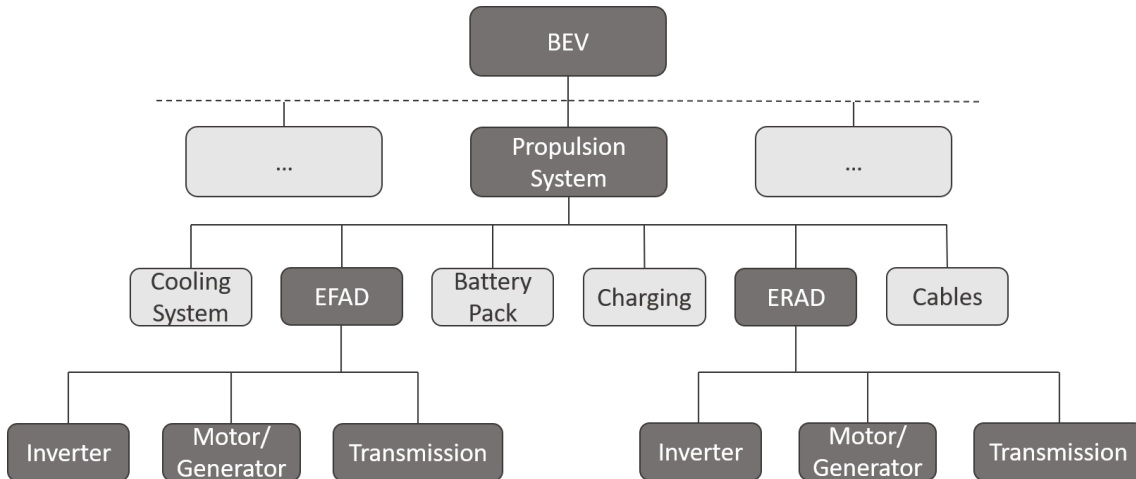

Figure 2: Conventional BEV System Chart. Tree chart illustrating the hierarchy of the BEV propulsion system, including EFAD and ERAD subsystems. [Own illustration].

2.3.1 Electric Machine

One of the driving elements in BEVs is the electric machine, further also denoted the machine, which is powered by electricity and consists of two basic elements; the stator and the rotor. The stator constitutes the stationary part of the machine, while the rotor is the rotating part, see Figure 3. Usually, the stator and the rotor are constructed differently depending on the machine type. The physical effect exploited in the electric machine is magnetism [30]. When a conductor, e.g. the stator, is fed with current a magnetic field is initiated. Moreover, when another magnetic field is introduced, e.g. in the rotor, the interaction between them generates a force which causes the machine to operate [31].

Electric machines in commercial BEVs typically run on three phase AC, since the rotation speed is easily regulated by changing the frequency of the AC. Since the machine rotation speed is very fast it needs to be slowed down through transmission onto the wheel axle, in order to achieve an appropriate wheel torque and speed. DC machines require less control electronics, but are not applied to the same extent in BEVs because of losses caused by physical wear on their brushes and commutators [32].

Furthermore, there are synchronous and asynchronous AC machines, depending on how the rotation speed of the machine matches the frequency of the AC that comes from the inverter, which is another important component of the driveline further explained in Section 2.3.2. In a synchronous machine its rotation speed matches the frequency of the incoming AC, while in an asynchronous machine it does not [33]. If unloaded, the asynchronous machine will rotate with the same speed as the magnetic field of the stator and if subjected to a load the machine will experience a decrease in speed, which is called backlog. This backlog increases with the load, which in turn gives a higher machine torque. Thus, the speed difference between

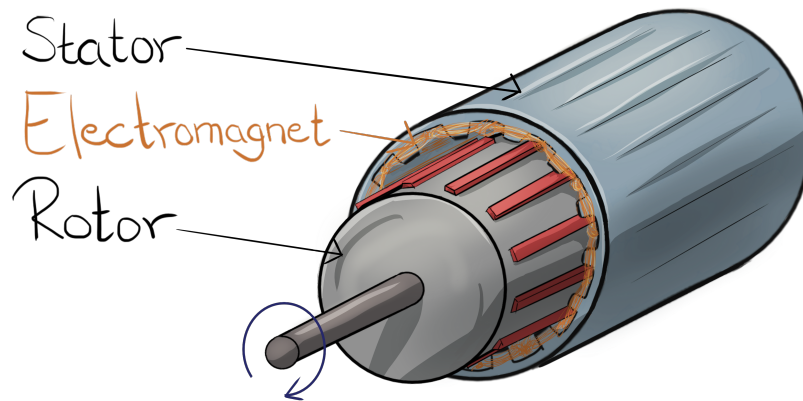

Figure 3: Stator and Rotor. Illustration of the rotor rotating inside the stationary stator. [Own illustration].

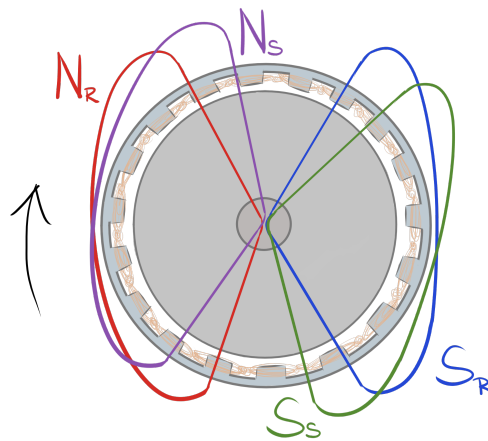

Figure 4: RMF Illustration. Two RMFs, one on the stator and one on the rotor, as a result of the attraction and repulsion of stator- and rotor- poles. [Own illustration].

the Rotating Magnetic Field (RMF) of the stator and the rotor determines the machine torque. The larger the speed difference, the higher the torque. As for synchronous machines, they are working at constant speed despite the load and if the load exceeds the initiate power, the machine will be overloaded and simply stop [34].

The stator of a synchronous and asynchronous machine is built in a similar manner. Usually it consists of copper wound coils constituting an electromagnet, whose poles are constantly switching places as a result of the AC feed, causing a RMF to occur. The rotor of a synchronous machine has magnetic poles made up by Permanent Magnets (PM) generating a magnetic field. The magnetic poles of the rotor chase the stator poles as they *attract* and *repel* each other making the rotor turn [35]. Thus, the RMF of the stator causes the magnetic field of the rotor to rotate resulting in two RMFs, see Figure 4. The PM machine is a commonly used synchronous machine in EVs, because of its efficiency characteristics and its relatively small size. Though it generates magnetic losses that affect its efficiency [36].

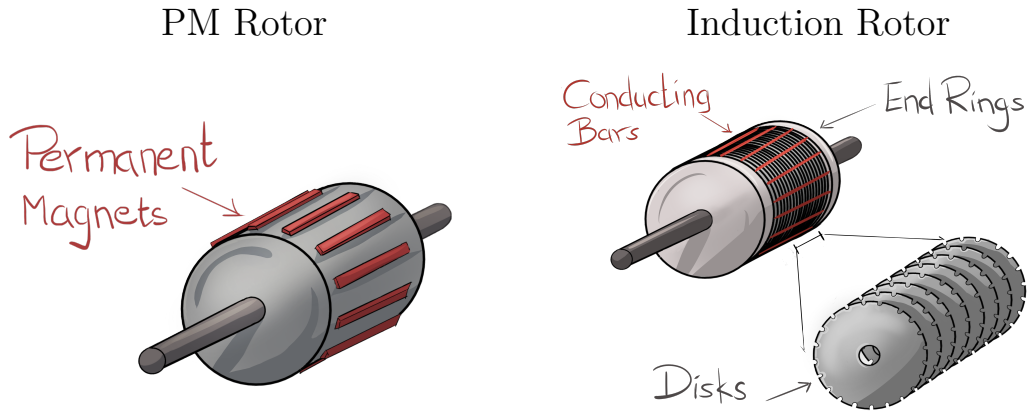

Figure 5: Rotor Comparison. The different rotor structures of the PM - and induction - machines.[Own illustration].

An example of an asynchronous machine is the induction motor invented by Nicola Tesla in 1887. It was the first AC machine not using any brushes or PMs [37],[33]. Instead of using PMs and brushes, the rotor consists of conducting bars of e.g. aluminium in the shape of a squirrel cage, that are short circuited by two end rings. The core of the rotor is made up by a set of disks e.g. of iron [38],[39]. Thus, both the stator and the rotor constitutes electromagnets. The coils in the stator receives three phase AC from the inverter, which generates a RMF as previously described. In turn the RMF of the stator induces the bars of the rotor, creating a second magnetic field which makes the rotor turn. A comparison of the rotors of the PM- and induction- machines, is presented in Figure 5.

In addition to the synchronous PM machine and the asynchronous induction machine, there are other machines used in EVs but to a lower extent. An example of which is the switched reluctance machine whose torque, apart from the previously presented machines, is determined solely by the magnetic *attraction* between the stator electromagnets and the rotor varying reluctance areas [34].

The machines presented are examples of the Radial Flux Machine (RFM), meaning that the direction of the produced magnetic flux is perpendicular the direction of the rotor axis. In addition to the RFMs there is the Axial Flux Machine (AFM) where the direction of the flux is axial and thus parallel the direction of the rotor axis. The structure of the RFM constitutes e.g. an internal rotor and an external stator as previously presented, while the structure of the AFM e.g. has one internal rotor and two external stators, one on each side, or vice versa [40]. The AFM is said to provide a higher power density compared to the conventional RFM, partly because of its electromagnetic topology as the flux path is shorter in the AFM [41],[42]. An illustration of the different structured machines including flux direction, is presented in Figure 6.

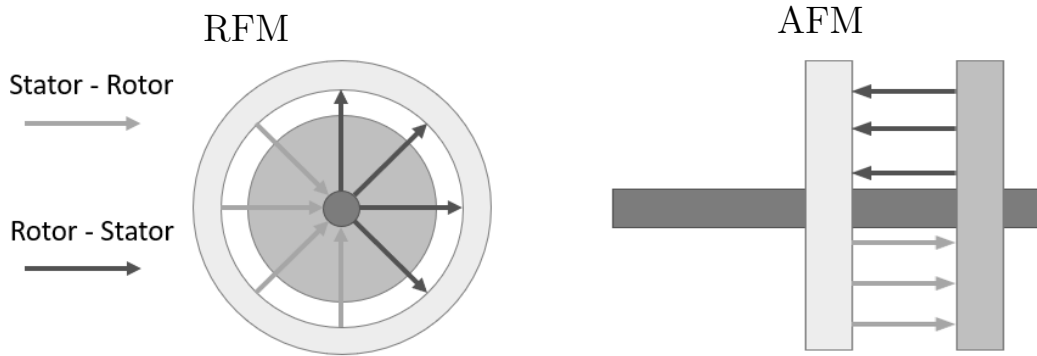

Figure 6: RFM and AFM Comparison. Own illustration of the structure and directional flux flow of the different machine categories, inspired by the graphic illustrations on the Magnax website [42].

The number of electric machines in EVs typically vary, compared to combustion vehicles that use one ICE. HEVs and PHEVs often use one ICE and one or more electric machines, while BEVs only use one or more electric machines. A common way of positioning the electric machine in any EV is coaxial to the drive axle, i.e. transversal to the driving course. Compared to the ICE the electric machine is effective within any speed range, which reduces the complexity of transmission onto the wheel axle, i.e. there is no need for a multi-gear gearbox [38]. Important aspects of the transmission elements utilised in BEVs is presented in Section 2.3.3.

2.3.2 Inverter

AC motors require elements to transform the DC from the battery to AC, which normally constitutes inverters with powerful transistors to be able to withstand the high current [33]. The powerful transistors generate heat and thus require effective cooling systems to function properly. Apart from converting the current, the inverter acts as the brain of the electric machine, regulating the frequency of the AC fed to the stator through intelligent software. To get an idea of the size of the inverter, a picture of an example of an inverter from an existing HEV relative a pen, is presented in Figure 7.

Acceleration is achieved by pressing down the acceleration pedal, causing the inverter to send out an increasing frequency AC to the machine activating its motor function. Moreover, as the acceleration pedal is released, the frequency AC to the machine is decreased and it starts to act as a generator instead. Thus it starts to generate AC that the inverter converts back to DC, which in turn charges the battery pack [43]. This is what is referred to as regenerative braking in EVs. In addition to converting the DC and controlling the frequency of the AC, the inverter can regulate the amplitude of the AC to control the power output of the electric motor [38].

As the machine in the propulsion system requires an inverter, the number of the two components usually align. There are two main ways of installing the inverter, as it can be integrated in the machine-housing or separate in its own housing [44].

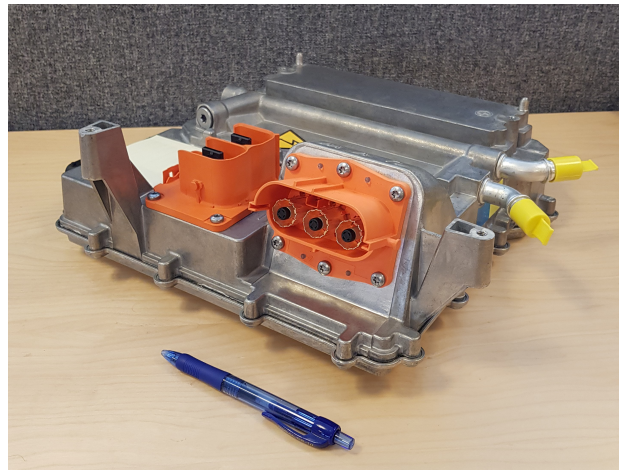

Figure 7: Inverter Relative Size. Own photograph illustrating the size of an inverter from a current HEV in relation to a pen.

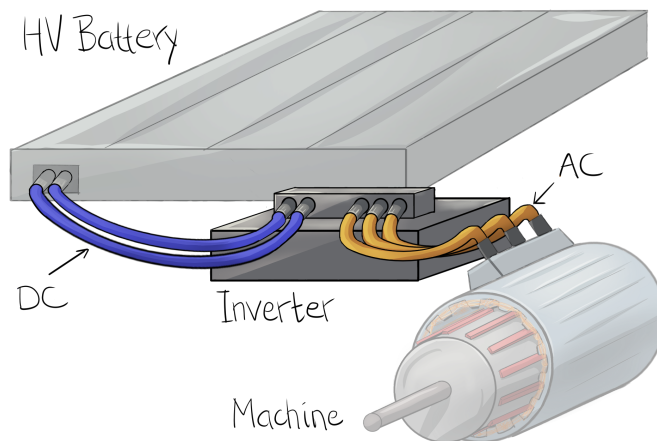

Figure 8: Inverter Cabling. Own illustration of how the inverter is connected to the machine and battery respectively, converting DC to AC.

The separated inverter can be mounted in various ways, which affect the cabling differently. To be able to remove the cabling between the inverter and the machine, the inverter has to be connected directly onto the machine, however the cabling between the inverter and the battery remains. If separated, the inverter can be rigged offset the machine, resulting in cables between them and the battery respectively. An illustration of how the machine, inverter and battery are connected is presented in Figure 8.

2.3.3 Transmission Elements

In most BEVs of today there is no gear shifting since there is one gear only. Hence in connection to the electric machine a fixed gear transmission still needs to be installed to match the speed of which the wheel axle rotates. An important trade-off when it comes to choosing gearbox is the balancing between acceleration and top speed. Many BEVs today use one-speed gears that facilitates high and constant torque from

zero, which contributes to low weight, cost and volume. Fast acceleration typically requires a higher torque at low velocity, and thus a lower gear, while fast top speed instead requires a higher gear. Thus, to be able to achieve both effects, a two-speed gear transmission needs to be installed [45].

ICE vehicles usually achieve AWD through the use of a propeller shaft and various types of gears, to distribute the power to all wheels. There are AWD- and Four-Wheel Drive (4WD) - systems, which are similar apart from 4WD-systems allowing the driver to manually engage or disengage one of the wheel pairs [46],[47]. The propeller shaft connects the front- and rear- wheel axles and is often parted and supported in the middle when the shaft is long and/or heavy, to avoid excess vibration when it rotates which would otherwise have a negative effect on its durability [48]. The two parts are typically connected through a rubber mounted bearing and at an angle, neither too small nor too large, to further decrease wear and noise from vibrations [49].

Another commonly used transmission element is the planetary gear, consisting of three different wheel types, namely; a sun wheel, planet wheels and a ring wheel. The sun wheel is located in the middle of the construction, around which the planet wheels are rotating. They are connected to a movable element that accommodates transferring the rotation onto e.g. a connecting axle. Moreover, the planet wheels are kept in place by the outer element of the construction which is the ring wheel. Hence, torque is being transferred from the sun wheel to the planet wheels [50]. Planetary gears are commonly utilised in connection to coaxially placed machines to transfer the power to the wheels.

Further, bevel gears are common elements used in transmission systems within automotive. They are shaped as cones, along the surface of which the teeth are located, making them well suited for applications including intersecting shafts [51]. There are different types of bevel gears and the angle of the cone can be adjusted depending on the application. Moreover, the teeth of the gear can be straight, spiral or hypoid which gives different characteristics. With straight teeth the entire tooth is engaged simultaneously, while in the case of hypoid teeth, only parts of the tooth are engaged at the same time. Hypoid bevel gears are commonly used in differentials [52]. An example of a bevel gear and a planetary gear is presented in Figure 9.

Differentials are other commonly utilised transmission elements in conventional drivelines. Two of their three main functions within the propulsion system include; transferring the power to the wheel axles and reducing the gear one last time to match the speed of the wheels. Yet the most important feature is their ability to allow wheels on the same axle to rotate at different speed [55].

Differentials include a pinion gear, a ring gear, spider gear(s) as well as side gears connected to the left and right drive shafts respectively, according to Figure 10. The pinion gear (6), at the end of the pinion shaft (7), rotates along the ring gear (2), while the spider gear (4) is mounted on the ring gear. When driving in a straight

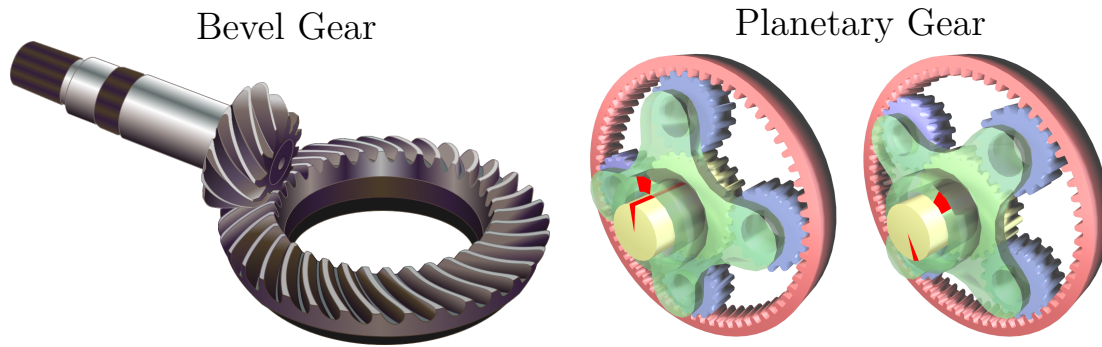

Figure 9: Transmission Components. Illustrations of a bevel- and planetary- gear, which are commonly used transmission elements in BEV- and non-BEV- AWD-systems. Pictures retrieved from Wikipedia [53],[54].

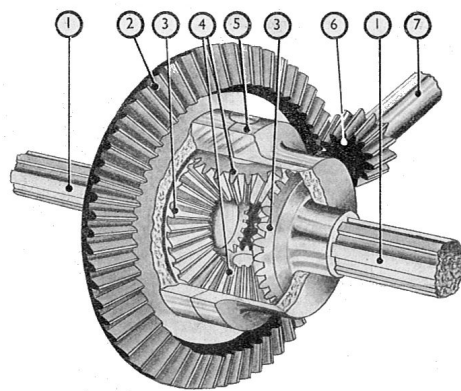

Figure 10: Standard Open Differential. Illustration of the structure of a standard open differential, acquired from Wikimedia Commons [56].

line the spider gears are locked in their position and the two side wheels (3) rotate with the same speed, i.e. the left and right drive shafts (1) rotate with the same speed. When turning, the spider gear starts to turn around its own axis resulting in one side gear rotating faster and the other being slowed down and thus allowing the two drive shafts, ergo the wheels, to rotate at independent speed [55]. The spider- and side- gears are surrounded by a housing (5).

2.3.4 Disconnect Clutch

A clutch is a device located between two working elements, with the function of engaging and disengaging them as needed [57]. Typically there are several types of clutches with different functions placed in a propulsion system. For a car with more than one machine installed, the disconnect clutch can disconnect the machine which does not have to operate in the current driving mode. In a HEV the clutch can disconnect the ICE whenever the electric machine is enough [58]. For a BEV, instead, the clutch can disconnect one of the electric machines if one alone can provide the required torque. In a BEV with two machines, one installed on the front axle and the other on the rear axle, the AWD can be substituted by Front-Wheel Drive

(FWD) or Rear-Wheel Drive (RWD), depending on which machine is the main drive one. Moreover a disconnect clutch can engage or disengage one of the wheel axles in a conventional, mechanical AWD system with one engine, when four wheel drive is redundant.

2.3.5 Battery Pack

The energy in a BEV is stored in the battery package consisting of battery cells connected to achieve a total voltage of about 400 V. Today most electric cars have cuboid shaped battery cells, however, there are also solutions with many small cylinder shaped battery cells similar to AA batteries [59].

A central issue for BEVs is the Technology Readiness Level (TRL) of batteries and studies are ongoing in order to develop and improve them further. TRL refers to the level of maturity of a certain technology [60]. Many different types of batteries have been and are still discussed. The technology that seems most promising in the nearest prospect is Lithium-ion batteries (Li-Ion), that exist in a number of varieties. Design improvements and new materials are studied in order to increase e.g. range and lifespan and to decrease cost [32].

3

Methodology

In this chapter the methodology followed within this project is presented and motivated, focusing on means to conduct the initial literature study followed by the technology analysis, dimensioning of the alternative propulsion layout and evaluating the final architectural design. The purpose of which is to guide the reader through the process and means of which the study has been carried out. An overview of the process that has been followed is presented in Figure 11.

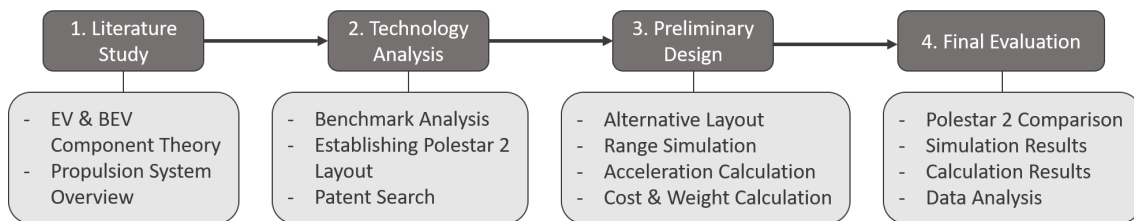

Figure 11: Methodology. Presenting the process steps that has been followed to conduct this project. [Own illustration].

3.1 Literature Study

Initially, a *Literature Study* was carried out to gather information on EVs and more specifically, BEVs, including general information of EVs as well as specific information of BEVs. The general structure of the BEV propulsion layout was established whereby deeper knowledge on its components was obtained. Theory on different implementations of components and their contribution to the function of the propulsion system has been studied and summarised to provide sufficient understanding to lead and follow the reasoning behind the development of the alternative propulsion layout.

Moreover the collection of information has been conducted by the means of scientific literature, including published articles and theses work. Even informative videos e.g. illustrating the functionality of the different components of the propulsion system layout, have been sources of information. Illustrations of theory results are represented by drawings created using the digital painting app Krita Desktop [61].

3.2 Technology Analysis

Next a competitor benchmark has been carried out, as part of the *Technology Analysis*, in order to map out the current BEV market and compare the reference car, Polestar 2, with its competitors. The benchmark has been conducted following the six steps presented in the method by Otto & Wood [62]. Relevant properties for comparison were specified and researched through the utilisation of a number of different sources. To make a fair comparison between various car models could be complicated when the data is collected from separate sources. A2Mac1 and Caresoft are two external companies providing data of different car models [63],[64]. They should be objective in respect to different OEMs, hence they were made the sources of first priority to the benchmarking when it comes to identifying competitors and gathering information on properties for comparison. Other assumed objective sources, such as car magazines, e.g. Teknikens Värld, have been used as priority two. Finally, when data has still been missing, the OEMs own web pages have been utilised. The data gathered was organised in an Excel [65] document and further analysed in terms of performance and segmentation.

In addition to the benchmark, a patent search has been carried out to investigate the Freedom To Operate (FTO) with the alternative propulsion layout following the method presented by Haldorson [66]. Thus a clearance search was conducted to detect the presence of similar solutions and possible infringement on existing patents. The main tools utilised for this purpose was the smart and advanced search options of the database Espacenet [67]. Relevant keywords to be investigated include a combination of electric, powertrain, propulsion and layout. Mainly the category of mechanical engineering was consulted. For further investigation of similar solutions and possible infringement, a more extensive clearance search has been carried out through the help of VCG.

Next the propulsion system layout of the reference car, Polestar 2, was mapped out and compared to other car models investigated in the benchmark. It was of importance to capture the knowledge existing at VCG, thus interviews with internals were conducted. People that have been taking part of the development of the propulsion system, having a good holistic view of it, as well as experts with deep technical knowledge have been answering questions and discussed different aspects of the project. The interviews have been managed in a semi-structured way, with a set of questions prepared in advance, but with a focus of keeping a dialogue and giving room for additional questions coming up along the way.

The main outputs of the technology analysis include the identification of the industry standard propulsion layout regarding premium BEVs as well as the mapping and comparison of the Polestar 2 layout. The result of the data collection has been summarised in tables, see, e.g. Table 1.

3.3 Preliminary Design

Within the *Preliminary Design* phase the alternative propulsion layout is developed based on the originally formulated concept idea. Based on the identified performance parameters of Polestar 2, a technical requirements specification has been formulated for the alternative propulsion layout. The technical requirements specification presents the *System*, *What* criteria has been set, *How* they should be verified and *Who* is the specifier [68]. The requirements have been updated as the development of the alternative propulsion layout has proceeded and make up the foundation for the comparison of the new propulsion layout and the one of Polestar 2.

Furthermore, based on the literature study results and the semi-structured interviews performed with technical experts within VCG, possible implementations of the alternative propulsion layout have been discussed. These implementations include which components that can be used and how they can be placed and positioned within the propulsion system, based on the wheelbase of the car.

The process of how the alternative propulsion layout has been dimensioned is then presented, starting with the electric machine. An existing machine has been scaled up and dimensioned in combination with the mechanical AWD transmission system, with the ambition to match the performance level of Polestar 2. The calculations used to assess the dimensions of the machine, the required power and torque, range and so on, are described in detail within Chapter 5.4. All calculations have been performed by the means of Matlab [69] simulations. Moreover, the range has been calculated through WLTC simulations in Matlab. To enable a fair comparison, both the propulsion layout of Polestar 2 and the alternative have been subjected to the same simulations.

Following the dimensioning, a cost- and weight- analysis was performed on both the propulsion layout of Polestar 2 and the alternative layout. The point of the analysis is to evaluate the effect of the dimensioning work and enable comparison between the two layouts. As information regarding cost and weight are confidential, the properties of the alternative propulsion system has been assessed in relation to Polestar 2. Conclusively, the main output of the preliminary design phase is an extensive description of how the methodology has been applied in the case of this study. Moreover, a minor sensitivity analysis has been carried out to evaluate the robustness of the dimensioning.

3.4 Final Evaluation

After the process of describing how the alternative propulsion layout has been dimensioned, it has been compared with Polestar 2 in the *Final Evaluation* phase. Based on the results of the calculations and consultation with technical experts within VCG, the final implementation of the alternative propulsion layout was established. The final propulsion layout, henceforth denoted *11:an*, has been compared to the

layout of Polestar 2 in terms of analysing the architectural design of the two. Further, the final dimensions of the machine utilised in the layout of 11:an are presented.

Moreover, a data analysis has been performed to evaluate the fulfilment of performance requirements as well as the target values on cost and weight. Since the data on cost and weight are confidential, variables have been assigned to the cost and weight of Polestar 2 respectively. Both the individual- and total- cost and weight of the layout components have been assessed. Hence, the result of 11:an has been presented as a percentage of the values of Polestar 2. This was done to be able to identify which parts of the propulsion layout increased and decreased in cost and weight and further to assess the total cost and weight of the system.

Regarding the results on acceleration and range, they have been presented in numbers obtained through the Matlab simulations as previously presented. Both the Polestar 2 layout and 11:an have been simulated using the same scripts to be able to compare the results. The results of the concept dimensioning and final architectural design have been illustrated by the means of tables and charts for transparency. Furthermore, the final layout of 11:an has been illustrated on its own as well as in comparison with the layout of Polestar 2. In all cases, the layout illustrations have been obtained from CAD models that have been assembled by reusing and adapting existing components. These CAD models have been achieved through the help of the project supervisor at Polestar [70].

4

Technology Analysis

With the ongoing technology shift from ICEs every automotive OEM will have to make a decision in which direction to invest Research and Development (R&D). Many OEMs plan for introducing BEVs in the market in the near future. This chapter aims to introduce the reader to the current BEV market, some of the active players, and available models within different segments. An outcome of the benchmark is the answer on how various OEMs have achieved AWD on an architectural level. Moreover the reference car, Polestar 2, is compared to its competitors in terms of performance followed by a dedicated presentation of its layout and technical specifications.

4.1 Current BEV Environment

In order to get a perspective of the present BEV environment, a benchmark and a patent search have been conducted. The results of which are presented and analysed within the following sections.

4.1.1 Benchmark

Volvo Cars is producing cars within the premium segment. Therefore, the benchmark has been focused towards cars within the same segment, although other models available in the market have been investigated. In Table 1 general data gathered in the search for information regarding relevant properties, such as performance parameters like acceleration and range, of some car models presently available on the market are listed. Polestar 2, which the alternative propulsion layout will be compared to, is included. It is analysed compared to its competitors separately in Section 4.1.2.

Many of the data are gathered from external databases, including Caresoft and A2Mac1 [64], [63], others are referred to within the table. The year presented within brackets in the *Car Model* column, refers to the model year the data concerns. In some cases there exist both prior and latter releases of the car model, however the ones presented are deemed most interesting for this project. As can be seen the acceleration from zero to 100 km/h, measured in seconds, varies from Tesla Model S Ludicrous Performance's 2.6 to Renault Zoe's 10.3. Moreover the range, measured in km, varies from BMW i3s Comfort Edition at 245 to Tesla Model S Long Range's 632. The values for the different ranges are for the most part based on the WLTP



Figure 12: Benchmark Segment Representatives. From the left: BMW i3s Comfort Edition, Tesla Model 3 Long Range and Mercedes-Benz EQC 400 4MATIC [71],[72],[73].

driving cycle, while others are based on NEDC.

The curb weight of the cars in total ranges from around 1500 to 2500 kg. The smaller cars weight roughly up to 1500 kg, while the Medium/Large/Executive Cars weight around 1500 - 2000 kg and SUVs weight circa 2000 - 2500 kg with some overlap. Pricing of the cars varies between brands, segments and car models from around 400 000 to 1 086 000 SEK. The price is for the most part based on the retail price in Sweden. In some cases, when the car models are not advertised and sold on the European market, but are interesting in terms of performance, the price has been converted from said currency into SEK for comparison. The BMW i3s Comfort Edition, Tesla Model 3 Long Range and Mercedes-Benz EQC 400 4MATIC representing the smaller-, medium/large/executive- and SUV cars respectively, are presented in Figure 12.

Another aspect is that several car models are offered in different versions, a standard and a longer range version for instance. In addition, there are usually a number of add-on options, hence each model are produced in several variants, for which cost, weight, acceleration and range can differ. Further, there are sometimes varieties between the different markets. This Master Thesis compare cars from the European market as the Volvo Cars headquarters are located in Gothenburg, Sweden, which is also the place where the Master Thesis is produced. Whenever data for such a model is not to be found, because of e.g. the model is not yet offered in Europe, the corresponding model from another market will do.

Analysing the data gathered, the different car segments provide different performance characteristics. The data presented in Table 1 gives an overview of the market offerings from the more affordable, smaller BEVs around 400 000 SEK, like the Renault Zoe or the BMW i3s, to the more expensive higher performance cars around the million SEK mark like the performance cars of Tesla. Polestar 2 belongs to the Medium/Large/Executive Cars segment. Since it is the reference car to which the alternative layout will be compared the premium cars within this segment, such as Tesla Model S and Model 3, are relevant to analyse in terms of performance. They both feature longer range and faster acceleration compared to their competitors. Overall, Tesla seem to surpass their competitors on performance in all segments they are present, though the competition within the SUV segment is more even.

Car models of extra interest are those available in two or more variants, where the most extreme one in terms of performance, has a higher number of machines. Tesla Model 3 is the one model investigated that comes in one- and two-machine variants. Apart from that, cars representative of the SUV segment are included because of their premium- and performance- characteristics. Data for the machines of these models are presented in Table 2. In all of the BEV car models investigated, the orientation of the machine(s) is transversal to the driving course as the machine(s) is mounted coaxial the wheel axle(s). Furthermore, the use of synchronous PM machines is common among the car models presented within this benchmark. As previously stated they provide high power whilst maintaining a small size. Tesla models utilise a combination of these PM machines and asynchronous induction motors to achieve the desired performance level. Tesla has several different models on the market today that all come in different versions in terms of performance level. These include standard, long range and (ludicrous) performance versions on top of which the customer can choose between RWD and AWD [87]. Thus, the different variants come with different number and type of machines.

The Tesla Model 3 Standard presented in Table 2 is a one machine RWD vehicle. It has a PM reluctance machine. The Long Range AWD version instead has two machines including an asynchronous induction motor in the front and a synchronous PM machine in the rear [79]. According to Tesla, the Model S and Model X variants utilise a combination of smaller and larger machines to achieve the desired specifications, depending on their performance level. Thus it is a way of managing the performance of the car models. E.g. the RWD- and the performance AWD- versions of Model S have a large machine installed in the rear to provide enough power to match the desired performance level. A smaller machine is mounted both in the front and the rear on non-performance AWD variants and in the front of performance AWD vehicles to compliment the larger machine in the rear [88]. Similarly for Model X, a larger machine is installed in the rear on performance vehicles, while a smaller machine is installed in the front of all AWD variants and in the rear of non-performance AWD vehicles [89]. Apart from the technological aspects of switching between smaller and larger machines to achieve a certain top speed or acceleration capacity, it is a way of communicating performance status to the customers.

Hence, as a first step of upgrading their vehicles Tesla adds a machine in the front and downsizes the rear machine of the vehicle when going from RWD to AWD. When increasing the performance further, the rear machine is sized up again while keeping the smaller machine in front. Many OEMs have been identified to follow their way of designing the propulsion system when developing their own BEVs and so Tesla has been the leading producer of BEVs. E.g. other car models interesting in terms of performance, include the Jaguar Land Rover I-Pace EV 400 and the Mercedes-Benz EQC 400 4MATIC. Both of which featuring a two-machine AWD solution, with one machine placed in the front and one in the rear. Thus, the way of achieving AWD in a BEV can be identified as having a machine mounted separately on the front and rear wheel axles of the car.

Table 1: General Benchmark Data. In the left column, car brands are listed followed by corresponding car model. Their acceleration, range, weight, and price are given in the following columns.

Benchmark Table - General Benchmark Data					
Brand	Car Model	Acc.[s] (0-100 km/h)	Range [km]	Weight [kg]	Price [kSEK]
Small Cars					
BMW	i3s Comfort Edition (2018)[74]	6.7	245 ¹	1385	410.4
Chevrolet	Bolt (2017) [75]	5.8	380 ¹	1618	450*
Renault	Zoe R110 Intens (2018)[74]	10.3	311 ¹	1581	347.1
Medium/Large/Executive Cars					
Hyundai	Ioniq electric ComfortEco (2018)[74]	9.3	280 ²	1520	397.9
Nissan	Leaf Acenta 40 kWh (2018)[74]	8.5	285 ¹	1655	374.9
Polestar	2 (2020)[76][77]	4.7	500¹	2155	640.1
Tesla	Model S Standard (2013)[78]	4.4	520 ²	1955	879
	Model S Long Range (2013)[78]	4.3	632 ²	2215	923
	Model S Ludicrous Perform- ance (2013)[78]	2.6	613 ²	2241	1 013
	Model 3 Standard (2018) [79]	5.1	415 ¹	1764	450
	Model 3 Long Range (2018)[72]	4.7	560 ¹	1747	616
	Model 3 Performance (2018)[72]	3.4	530 ¹	1847	733
SUVs					
Hyundai	Kona Electric Long Range Trend (2018)[80]	7.2	482 ¹	1792	409
Jaguar	Land Rover I-Pace EV 400 (2018) [81],[82]	4.8	470 ¹	2257	884.9
Mercedes- Benz	EQC 400 4MATIC (2019*) [83],[84]	5.1	425 ¹	2425	686*
Tesla	Model X P90D Long range (2016)[85]	4.9	565 ²	2459	1 004
	Model X P90D Ludicrous Performance (2016)[85]	3.0	542 ²	2509	1 086
	Model Y Long Range (RWD) (2019)[86]	5.8	540 ¹	–	621
	Model Y Long Range (AWD) (2019)[86]	5.1	505 ¹	–	666
	Model Y Performance (2019)[86]	3.7	480 ¹	–	757

* Values are based on estimations, ¹ WLTP, ² NEDC.

Table 2: Motor Specific Data. In the left column, car brands are listed following by corresponding car models. Subsequent columns present the number of, type and position of, and drive type of the machine(s) utilised in each car model.

Benchmark Table - Motor Specific Data				
Brand	Car Model	No.	Type & Position	Drive
Jaguar	Land Rover I-Pace EV 400	2	Synchronous AC PM machine front and rear [81]	AWD
Mercedes-Benz	EQC 400 4MATIC	2	Asynchronous AC machine front and rear [83]	AWD
Polestar	2	2	Synchronous AC PM machine front and rear [76]	AWD
Tesla	Model 3 Standard	1	Synchronous AC PM reluctance machine rear [79]	RWD
	Model 3 Long Range	2	Asynchronous AC induction motor front and synchronous PM machine rear	AWD
	Model 3 Ludicrous Performance	2	Asynchronous AC induction motor front and rear [79]	AWD
	Model X P90D Long Range	2	4 pole asynchronous AC induction motor with a copper rotor	AWD
	Model X P90D Ludicrous Performance	2	4 pole asynchronous AC induction motor with a copper rotor front and rear [90]	AWD

Apart from the recently released Tesla Model 3, looking into the upcoming release of BEVs, there is the Volkswagen Neo and Porsche Taycan that are both expected to be released in 2020 [74]. Moreover, Audi’s E-Tron GT and BMW i4 are both presented to rival Tesla and will be released in 2020 and 2021 respectively [91], [92]. As previously presented, Polestar 2 belongs to the generation of BEVs that will roll the streets in year 2020.

4.1.2 Polestar 2 Comparison

When comparing the acceleration capacity of the car models presented in Table 1, values within the span of ± 0.5 from Polestar 2’s 4.7 s has been investigated. Thus, to compare Polestar 2 with its premium competitors in the Medium/Large/Executive Cars segment, its acceleration capacity is identical to Tesla Model 3’s Long Range performance of 4.7 s. Furthermore, Tesla Model S Long Range- and Standard- variants provides faster acceleration in 4.3 s and 4.4 s respectively, while Tesla Model 3 Standard accelerates in 5.1 s which is slower. Moreover, Polestar 2 is significantly faster than non-premium Hyundai Ioniq and Nissan Leaf, but not on the same level as the performance versions of Tesla Model S and Model 3. Providing fast acceleration is considered a positive feature. How Polestar 2 performs compared to its

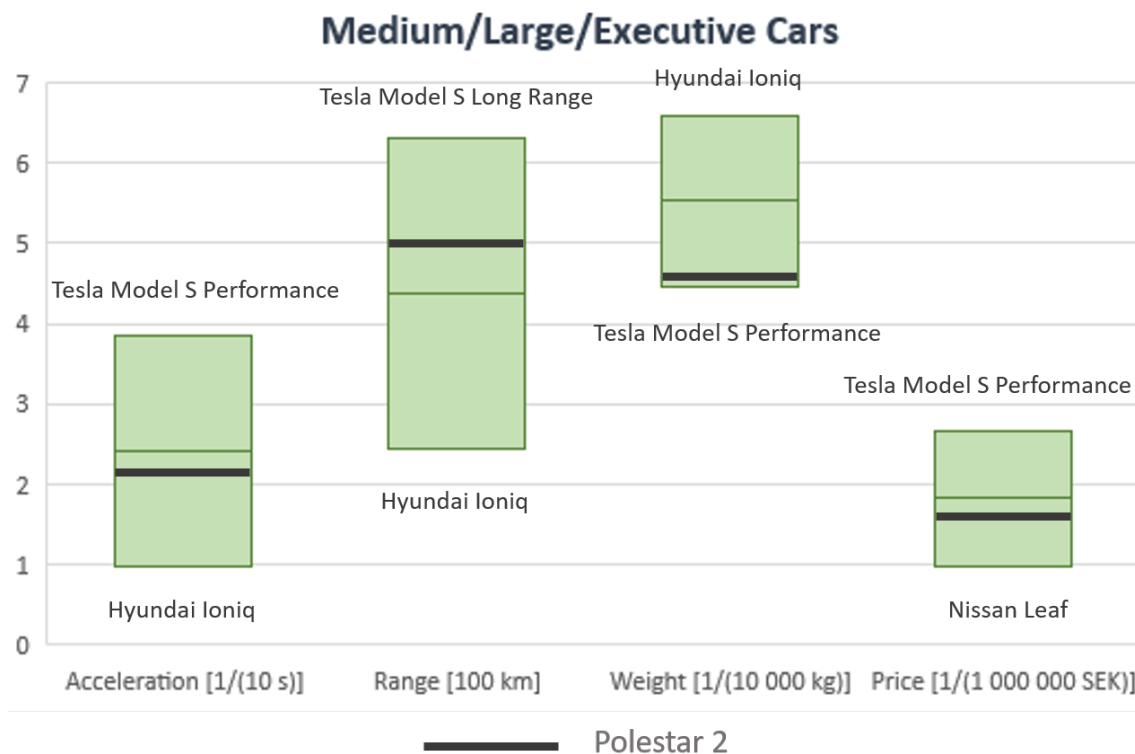

Figure 13: Medium/Large/Executive Cars. Comparative study of Polestar 2 and its competitors within the corresponding car segment. [Own illustration].

lowest- and highest- performing competitors within this car segment, is illustrated in Figure 13. As can be seen Polestar 2 performs better than average compared to the other car models within the segment.

When it comes to range, the longer is considered the better. Polestar 2 is said to reach 500 km, which is above the average range. Moreover it is rather longer than Tesla Model 3 Standard’s 415 km. Polestar 2 is somewhat comparable with the Performance version of Tesla Model 3’s 530 km. Tesla Model S Standard performance has a range of 520 km according to NEDC, which is closer to Polestar 2, however the test cycles used differ which impedes direct comparison. WLTP, which the Polestar 2 range is based upon, is considered a tougher method of testing. Again, Polestar 2 has considerably longer range than Hyundai Ionic and Nissan Leaf, but it does not top the range of Tesla Model 3 Long Range featuring 560 km. Tesla Model S Long Range and Ludicrous Performance both exceed 600 km according to NEDC.

Like many of the car models presented in Table 2, Polestar 2 uses two machines to achieve AWD. The two PM machines are located in the front- and rear- axles respectively, alike other two-machine solutions. Regarding weight, Polestar 2 is on the heavier side weighing over 2000 kg along with Tesla Model S Long Range and Ludicrous Performance. A lower weight is considered a positive feature as it e.g. enables longer range. As for the price, it starts at 640 100 SEK which is below average and comparable with the starting price of Tesla Model 3 Long Range. Here

a lower price has been considered a positive feature as it corresponds to being more competitive. However, what is considered positive regarding price depends on the customer's perceived value of the car.

Apart from the car models within the Medium/Large/Executive Cars segment, there are SUVs with performance parameters comparable with Polestar 2. However, since they belong to another segment of cars they have not been examined in detail within this project. Overall, looking at the data presented in Table 1 and 2, Polestar 2 can be compared to Tesla Model 3 Long Range. The major difference, regarding the data presented, lies in the front machine type. A more detailed description of Polestar 2 is presented in Section 4.2.

4.1.3 Patent Search

Initially a brief patent search was carried out to investigate the BEV environment and the uniqueness of the idea behind the alternative propulsion system layout, which is presented in Section 4.2. The results of which indicating little or no risk of infringement at the current level of detail. A trend of optimising the BEV driveline towards higher performance, lower weight and compactness has been identified [93],[94]. There are however patents on AWD systems including different clutches and their position in the powertrain [95],[96], which should be considered when developing a more detailed level of the alternative concept layout. Moreover, developments of the PLM in EVs have been identified [97].

The matter was then investigated further in a more extensive patent search through the help of VCG, resulting in findings of similar solutions utilising one electric machine and mechanical transmission to achieve AWD [98]. This patent is expired and thus the risk of infringement was established to be low.

4.1.4 Summary of the Current BEV Environment

To conclude the findings of the current BEV environment, an increasing number of OEMs are embracing electrification and entering the BEV market. From the car brands and models investigated, the industry standard layout of a premium BEV achieving AWD has been identified as using two electric machines, one on the front- and one on the rear- axle of the car. The machines are mounted transversal to the driving course and coaxial to the wheel axles. Moreover, Tesla has been identified as the leading technology actor on the premium BEV market, by whom other OEMs seem inspired when it comes to propulsion layouts.

Comparing Polestar 2 with the Tesla models in the Medium/Large/Executive Cars segment, it rivals Model 3 Standard and Long Range in terms of acceleration capacity. Further it is fairly close to Tesla Model 3 Performance when it comes to range and it out-ranges Tesla Model 3 Standard. Looking at both acceleration capacity and range, Polestar 2 is comparative with Tesla Model 3 Long Range. The most expensive and highest performance premium BEVs still provide superior ac-

celeration and range characteristics. However, it can be concluded that Polestar 2 aims at providing performance rivalling the performance market leading actor Tesla.

4.2 Polestar 2

The reference car, with which the alternative driveline layout will be compared, is Polestar 2. Polestar's very first BEV was revealed on the 27th February 2019 through a live broadcast where the car was presented by the Chief Executive Officer (CEO) Thomas Ingenlath. The production of the car is planned to start in February 2020 [99]. Figure 14 shows the side view of the car model.

Polestar 2 is marketed to offer sustainable mobility and a truly modern driving experience through "outstanding design, a powerful electric performance, and a seamless integration to your digital life" [99]. The OEM claims that the Polestar 2 provides electric performance and efficiency by means of their electric drivetrain. Further, the car features regenerative braking [76]. In connection with the reveal the configuration tool was opened, hence one can already now order a Polestar 2. At an initial stage the AWD version with two machines, one EFAD and one ERAD, will be available. This is of interest for the Master's Thesis since Polestar 2 has the set up with two machines to increase the power. There is also an optional performance package including special brakes, dampers, rims, and golden seat belts and brake calipers [99].

Representing the "industry standard" propulsion system layout, from what has been found through the benchmark, Polestar 2 makes a good reference for the Master Thesis. Also, offering a dual motor version with high performance is in line with the trend seen among other car models.



Figure 14: Polestar 2. Side view of Polestar 2, acquired from Polestar's website [13].

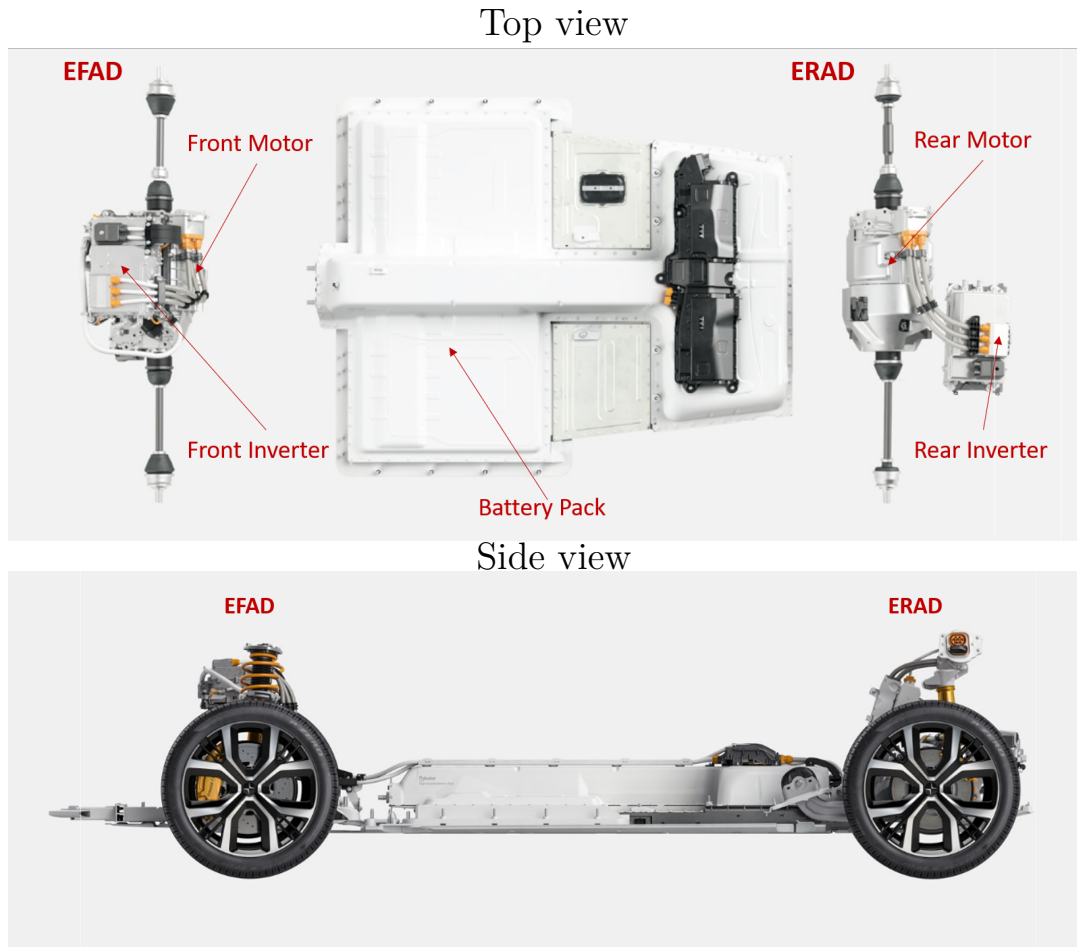

Figure 15: Polestar 2 Propulsion Layout. Top view and side view of the Polestar 2 propulsion layout, acquired from Polestar’s website [76]. The car front is to the left.

4.3 Polestar 2 Propulsion Layout

The focal points of the propulsion system of Polestar 2 are the EFAD and ERAD, as they make the foundation for the comparison with the alternative layout. Components included in the subsystems are the electric machine, inverter, and transmission. The battery pack is not scrutinised here since it is not within the scope. It is however an interesting and important component from both a cost and a weight point of view. Additionally, as the battery capacity is highly correlated with the vehicle range the system is most likely affected by the result of the study. In Figure 15 the top- and side views of the system are shown and the different components are indicated, where the front of the car is to the left.

4.3.1 Electric Machine, Inverter and Transmission

Polestar 2 has two PM machines, one placed in the front and rear respectively, as previously presented. The machines can provide a power of 150 kW and a torque of

330 Nm each. Thus the total power and torque the machines can minister is 300 kW and 660 Nm [76]. The machines are placed coaxial to the wheel axles, which can be seen in Figure 15.

In connection to the front and rear machines, Polestar 2 has a DC to AC inverter mounted respectively [76]. As can be seen in Figure 15 the front inverter is positioned above the front machine housing, while the rear inverter is placed aslant to the rear drive axle. Thus the inverters are both installed separated, or offset, from respective machine housing.

Polestar 2 provides fixed gear transmission and AWD. Moreover, transmission of torque from the machines onto the drive axles is achieved through the use of planetary gears integrated in respective machine housing.

4.3.2 Battery Pack

The lithium-ion battery pack of 27 modules has a capacity of 78 kWh. Each module consists of 12 battery cells, thus there are in total 324 cells in the entire battery pack. With flat pouch cells multiple layers are packed in a compact way. In the bottom of the pack there is a cooling plate and the whole battery is protected by a rigid enclosure. The stiffness of the battery is also positive from a Noise, Vibration, and Harshness (NVH) point of view as it is utilised to reduce noise and vibrations [99]. How the battery size is related to the other components in the propulsion system can be viewed in the top view in Figure 15.

4.4 Technical Specifications

The data gathered on Polestar 2 characteristics have been summarised in a list of technical specifications, as can be found in Table 3. EFAD and ERAD, as defined by this project, both include machine, respective inverter and transmission elements. These data make up the foundation of how the requirement specification of the alternative propulsion layout has been formulated, which is presented in Chapter 5.2. Capacity parameters that need to be fulfilled by the alternative propulsion layout are those on range and acceleration. Other parameters like the motor power, torque, etc. are expected to deviate from the reference values in order to reach the required range and acceleration properties. Moreover, general dimensions including length and height of Polestar 2 are presented in Table 4.

Table 4: Polestar 2 dimensions [76]. In the left column the length of the car is presented, followed by the height of-, the width of- (including mirrors) and the wheelbase measurements.

Technical Specifications - Polestar 2 Dimensions			
Length [mm]	Height [mm]	Width [mm]	Wheelbase [mm]
4607	1478	1859	2735

Table 3: Polestar 2 data. In the left column the components and subsystems are stated, followed by their weight and cost. X and Y denotes the total cost and weight of the system respectively. X_1 and Y_1 is the cost and weight of EFAD, while X_2 and Y_2 is the cost and weight of ERAD. Moreover the properties of the components and subsystems are presented.

Technical Specifications - Polestar 2 Data			
Components	Cost [SEK]	Weight [kg]	Properties
Total vehicle	–	2155	Curb weight
Propulsion system	X	Y	Including EFAD, ERAD and battery pack
EFAD	X_1	Y_1	PM motor, total power 150 kW, total torque 330 N m
ERAD	X_2	Y_2	PM motor, total power 150 kW, total torque 330 N m

5

Preliminary Design

The following chapter aims at guiding the reader through the process of defining the alternative propulsion layout, starting with a description of the new concept idea of achieving AWD in a premium BEV. Moreover, a technical requirements specification for the alternative propulsion layout is presented, followed by possible ways of implementing the different components in the layout. The chosen implementations of components are then motivated. Further, the process of dimensioning the layout is presented, including calculations performed on machine dimensions as well as performance parameters such as range and acceleration. Lastly, the process of which the cost- and weight- analysis has been conducted is explained. The results of the dimensioning process are compared with Polestar 2 in Chapter 6 and are further evaluated in terms of fulfilment of said technical requirements.

5.1 Concept Description

The idea behind the alternative electric propulsion layout is to achieve AWD with *one* large machine in combination with a propeller shaft and transmission components, typically used in ICE vehicles, as opposed to using *two* smaller machines on the front and rear wheel axles which has been identified as the industry standard when it comes to premium BEVs. Hence, the alternative layout combines the new electric system with a traditional, mechanical way of obtaining AWD. Thus, the alternative propulsion system needs to include wheel axles, a propeller shaft, a machine, inverter, transmission components and a battery pack.

5.2 Technical Requirements

Target values are set for important criteria that need to be fulfilled by the alternative propulsion layout, which are presented as list of technical requirements, see Table 5. In order to be able to make a reasonable comparison between the alternative propulsion layout and the reference one, target values on performance are based on the performance parameters of Polestar 2. The level of the requirement is identified as a *need* or a *want*, where a need requirement represents criteria that has to be fulfilled.

Requirements marked with want indicate criteria that are desirable to fulfil, however the solution will not necessarily fail if they are not met. These desirable criteria are weighted on a scale of one-to-five, where a higher number represents increased desirability, illustrating which ones are more or less important to fulfil. Methods

used to verify the fulfilment of the criteria include e.g. calculations and consultation with experts. Moreover the stakeholders who are responsible for the requirements are the project owners for the most part, who are further referred to as *Elvorna*.

5.3 Alternative Propulsion Layout

Based on the original concept idea presented in Section 5.1, components required to propel the vehicle have been specified. Moreover, possible implementation variations of the components, including positioning and placement have been identified. Within the following sections, the development process of the alternative propulsion architecture is presented. The final result of what components were decided upon, their positioning within the layout and why, is then motivated.

5.3.1 Components

Starting with the electric machine, it can be e.g. a PM synchronous machine, an induction motor or an axial flux machine as are presented in Chapter 2.3.1. These have different characteristics and thus provide different advantages and disadvantages. Looking at automotive applications, the PM synchronous machine and the induction motor has a higher TRL compared to the axial flow machines. Moreover the PM synchronous machine produces magnetic losses, however it is efficient relative its small size. While the induction motor is a more complex construction, it does achieve the RMFs without the use of PMs or brushes. Since the PM synchronous machine is utilised in Polestar 2, the comparison between the machines is more intuitive if such a machine is dimensioned for the alternative layout. Thus a PM synchronous machine has been dimensioned for 11:an, for the calculations see Section 5.4.1.

In connection to the machine, an inverter needs to be installed to transform the DC from the battery pack to AC. The inverter needs to be compatible with the 400 V system as presented in Table 5, while having the capacity to feed the machine with the amount of current it requires. In order to be compatible with the machine, an alternative is to size-up an existing inverter in terms of capacity. Consulting with technical experts, such an inverter can be estimated by assuming a cost of 85 % of the total inverter cost of Polestar 2. Another alternative similar to the first, include integrating two inverters in the same housing, whereas a third alternative would be to include two separate inverters and connect each to a connector on the machine. Using two inverters will enable achievement of capacity, however it will have a neutral effect on the cost and weight of the propulsion system. Consequently in 11:an, an up-sized inverter with the corresponding capacity of the new machine is assumed with a cost of 85 % of the inverter cost of Polestar 2.

Regarding the transmission components, the front- and rear- drive shafts are the same in the alternative propulsion layout and Polestar 2. When integrating the electric- and mechanical- systems, a fixed gear transmission is required between the machine and propeller shaft to transfer the power to the front- and rear- wheel

Table 5: Technical Requirements. In the left column the criteria is presented, followed by the target value and the level of requirement. Then the weight of the desired criteria is presented along with verification method and specifier. $t_{a,PS2}$ represents the acceleration capacity of Polestar 2 and D_{PS2} its range. X represents the total propulsion cost of Polestar 2, and Y represents its total weight.

Technical Requirements					
Criteria	Target Value	Need / Want	Weight	Verification Method	Stakeholder
Performance					
Acceleration (0-100 km/h)	$t_{a,PS2} \pm 5\%$	N	–	Matlab Simulation	VCG
Acceleration (0-100 km/h)	$t_{a,PS2} \pm 1\%$	W	3	Matlab Simulation	Elvorna
Range	$D_{PS2} \pm 5\%$	N	–	Matlab Simulation, WLTC	VCG
Range	$D_{PS2} \pm 1\%$	W	3	Matlab Simulation, WLTC	Elvorna
Weight & Cost					
Propulsion System cost	$\leq X$	N	–	Excel Calculations	VCG
Propulsion System cost	$< 0.95X$	W	4	Excel Calculations	Elvorna
Propulsion System weight	$\leq Y$	N	–	Excel Calculations	VCG
Propulsion System weight	$< 0.95Y$	W	5	Excel Calculations	Elvorna
Dimensions					
Machine Diameter	≤ 300 mm	N	–	Matlab Calculations	Elvorna
Machine Length	≤ 500 mm	N	–	Matlab Calculations	Elvorna
Voltage System	400 V	N	–	Matlab Calculations	VCG

axles. This can be achieved through the use of gears with e.g. straight or angled teeth. The fixed gear transmission of the alternative layout consists of angled gears to transfer the power to the front and rear wheel axles. Moreover, to transfer the power from the propeller shaft to the wheels, front- and rear - drive units needs to be installed. Hence a Front Drive Unit (FDU) is mounted between the propeller shaft and the front wheel axle, while a Rear Drive Unit (RDU) is installed in connection to the rear wheel axle of 11:an. These drive units include e.g. bevel gears and a differential. Sometimes also a disconnect clutch is included. The FDU constitutes a mirrored and adapted version of an existing RDU component used in conventional AWD cars of Volvo. The RDU presented is also a modified version of the existing RDU. However, in the alternative layout the disconnect clutch is being excluded in both the FDU and RDU, for AWD comparison.

The propeller shaft, stretching from the front- and rear- wheel axles, can be a one part straight component or parted at an angle on one or more places to improve NVH characteristics. Whether or not it can be a one part component depends on the length of the shaft. The propeller shaft of the alternative propulsion layout is a two part shaft connected at an angle to improve NVH characteristics and it is based on existing components utilised in AWD cars of Volvo today. Most of the transmission elements should be based on existing components within the company, since the technology is well know.

5.3.2 Positioning and Placement

The wheel axle dimensions depend on the wheelbase and width of the car, which in turn varies with different vehicle platforms. Thus, the wheelbase makes up a set foundation for the rest of the layout. The propeller shaft is preferably placed in the middle of the propulsion system and stretches between the two wheel axles.

When it comes to the machine, it can be positioned transversal to, at an angle to or aligned with the propeller shaft. Moreover it can be placed on either side of the propeller shaft and in the front-, middle- or rear- of the vehicle. Further, the machine can be mounted offset or coaxial to the propeller shaft. Mounting the machine coaxial to the shaft results in a more complex and expensive construction as both axles are coincided, in which case a planetary gear is required to ratio the motor speed onto the propeller shaft. Thus, in 11:an the machine is positioned parallel and offset the propeller shaft. When the machine is placed offset the propeller shaft the fixed gear transmission needs to be installed between the two. Thus the positioning of the fixed gear transmission is depending on the placement of the machine.

The positioning and placement of the inverter is not necessarily restricted by the positioning and placement of the machine, though the resulting cabling is affected by the distance between them. Consequently, the inverter can be placed on either side of the propeller shaft and in the front-, middle- or rear- of the vehicle. Furthermore it can be positioned bolt on- or offset- the machine in any direction. In 11:an the up-sized inverter is installed offset the machine, parallel to the propeller shaft

on the opposite side of the machine. The position of the inverter is also parallel to the ground.

From the machine to the wheels there is an overall gear transmission of about 10:1. Between the machine and the propeller shaft a fixed gear transmission with the ratio of about 4:1, is installed to transfer the power to the front- and rear- wheel axles. The propeller shaft itself is installed in the centre of the driveline, stretching from the front- to the rear- wheel axle with the total length of about 2740 mm. In the front of the propeller shaft the FDU is installed while the RDU is installed in the rear, to further transfer the torque to the wheels. The size and positioning of the battery pack will be affected by the new layout, especially since the propeller shaft is added. This is further discussed in Chapter 7.1.

5.4 Dimensioning

The electric *machine* has been dimensioned and the *range* and *acceleration time* from 0 to 100 km/h has been determined by the means of Matlab simulations. The machine requirements, the range, and the acceleration time depend on each other, hence iterative calculations were done. To enable fair cost and weight comparisons the capacity of 11:an has to be adequately equal to the capacity of Polestar 2. The dimension work is based on the requirements specification, presented in Table 5.

The Worldwide Harmonised Light-duty Vehicle Test Cycle (WLTC) was utilised to decide the range of the alternative- as well as the reference propulsion layout. Both layouts have been tested in order to make the comparison between the two as fair as possible. WLTC is a 30 minutes long test drive cycle based on real driving data coming from several parts of the world [100]. The profile of WLTC can be seen in Figure 16. The total distance of the cycle is approximately 23.3 km.

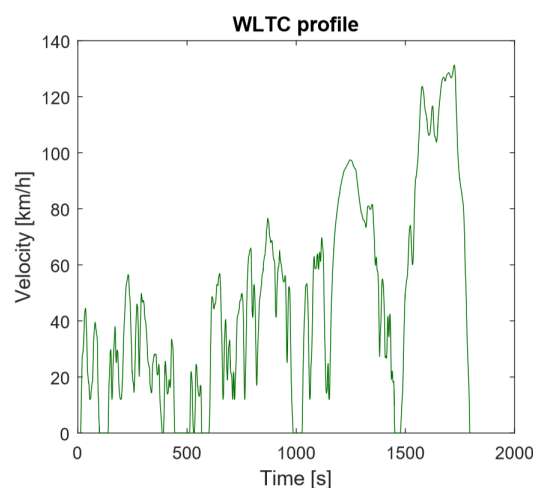

Figure 16: The profile of WLTC. It is represented as a graph describing the velocity as a function of time. The total cycle duration is 1800 s and reaches a maximum velocity of 131.3 km/h. [Own graph].

5.4.1 Machine

The electric machine was the first component to be dimensioned, with the target to get sufficient torque and power. Equation (1) has been utilised to set the machine measures. The equation has been derived from a general electric machine formula [101] with the only modification that the constant has been set to $\frac{\pi}{2}$, due to simplification. The choice of equation has been proposed and discussed with Professor Torbjörn Thiringer [102].

$$P = T\omega \approx \frac{\pi}{2}(\bar{B}\bar{A})D^2L\omega, \quad (1)$$

where

P is the machine power [W],

T the machine torque [Nm],

ω the angular frequency [rad/s],

\bar{B} the specific magnetic loading [T],

\bar{A} the specific electric loading [A/m],

D the machine diameter [m], and

L the machine length [m].

An existing machine, henceforth denoted *Alpha*, made the starting point for the calculations. In order to meet the desirable properties the machine was scaled up accordingly. Some modifications were needed as the power of Alpha does not reach the required power level. The power can be increased by increased torque, rotational speed, or both, as can be seen in Equation (1). Furthermore, the torque is proportional to the product of the specific magnetic loading and the specific electric loading and the volume of the machine. The torque/range proportions for the the two Polestar 2 machines and Alpha are not identical, hence various combinations were tested until the iterating process resulted in the configurations that from here and on will be denoted *Beta*.

Equation (1) was used to determine the parameters for Beta in the *field weakening point*. The product $(\bar{B}\bar{A})$ was kept constant, at the level of Alpha. A table with various combinations of power, rotational frequency and diameter was created and based on those values the torque and machine length was calculated for each alternative. The different machine settings is shown in Figure 17. The final combination of parameters was then elaborated to enable the machine characteristics of Alpha to be scaled to the desirable levels of Beta.

Machine specifications									
Variables			P [kW]	T	w	BA	D	L	
1	P_1	w_A	D_I	205	652.5353	3000	40000	0.25	0.166167
2			D_II	205	652.5353	3000	40000	0.26	0.15363
3			D_III	205	652.5353	3000	40000	0.27	0.142461
4		w_B	D_I	205	593.2139	3300	40000	0.25	0.151061
5			D_II	205	593.2139	3300	40000	0.26	0.139664
6			D_III	205	593.2139	3300	40000	0.27	0.12951
7	P_2	w_A	D_I	220	700.2817	3000	40000	0.25	0.178325
8			D_II	220	700.2817	3000	40000	0.26	0.164872
9			D_III	220	700.2817	3000	40000	0.27	0.152885
10		w_B	D_I	220	636.6198	3300	40000	0.25	0.162114
11			D_II	220	636.6198	3300	40000	0.26	0.149883
12			D_III	220	636.6198	3300	40000	0.27	0.138987
13	P_3	w_A	D_I	260	827.6057	3000	40000	0.25	0.210748
14			D_II	260	827.6057	3000	40000	0.26	0.194848
15			D_III	260	827.6057	3000	40000	0.27	0.180682
16		w_B	D_I	260	752.3688	3300	40000	0.25	0.191589
17			D_II	260	752.3688	3300	40000	0.26	0.177135
18			D_III	260	752.3688	3300	40000	0.27	0.164257
19	P_4	w_A	D_I	300	954.9297	3000	40000	0.25	0.243171
20			D_II	300	954.9297	3000	40000	0.26	0.224825
21			D_III	300	954.9297	3000	40000	0.27	0.20848
22		w_B	D_I	300	868.1179	3300	40000	0.25	0.221064
23			D_II	300	868.1179	3300	40000	0.26	0.204386
24			D_III	300	868.1179	3300	40000	0.27	0.189527

Figure 17: Alternative Machine Dimensions. Presenting the generated machine specifications and dimensions. [Own figure].

Effective power can be expressed as

$$P = UI \cos \varphi, \quad (2)$$

where

P is the power [W],

U the voltage [V],

I the current [A], and

φ the phase difference [rad], and $\cos \varphi$ makes the power factor [103].

Thus, the power is proportional to the voltage and the current. It implies that the voltage, the current, or both needs to be increased to meet the required increase in power. Here, the maximum voltage will be a limiting factor, as a requirement is that the alternative should be a 400 V system. Consequently, it requires the system to manage high currents.

Based on the calculations performed, Beta has a diameter of 260 mm, a length of 195 mm and thus a volume of around 10.4 dm³, which is equal to 10.4 litres. Further, Beta has a maximum torque of more than 800 Nm, a base speed of 3000 rpm, and a maximum power of almost 260 kW.

5.4.2 Range

The range has been simulated by means of a Matlab script for which the WLTC cycle has been utilised. The estimated range for one full charge has been set according to Equation (3). The procedure and set of equations for the range calculations are proposed by technical specialist Bengt Noren [104].

$$D = \frac{E_{battery}}{e}, \quad (3)$$

where

D is the range (distance of travel) [m],

$E_{battery}$ the battery capacity [Ws]=[J], and

e the energy consumption per length unit [Ws/m]=[J/m].

This approach uses the WLTC but is not following the WLTP completely. Instead an average level of required energy is estimated. Assuming that WLTC is representing a good estimation of a typical average energy consumption, the range can be estimated by the relation between e and the battery capacity, which is known. Based on the WLTC, e is the total energy required to generate the necessary torque over the travel distance of the same cycle and calculated according to Equation (4).

$$e = \frac{E}{d}, \quad (4)$$

where

E is the energy [J], and

d the travel distance of the WLTC [m].

The distance of the WLTC is known. The energy consumed during the cycle is determined by Equation (5).

$$E = \int (P + P_L) dt, \quad (5)$$

where

P is the machine power [W], and

P_L the power loss in the machine and the inverter [W].

By representing the machine and inverter losses the power losses are taken into consideration during all the driving modes, thus enables the regenerative braking to be included in the calculations. Here " P_L -maps" where the power loss is indicated for a given machine torque and a given rotational speed have been used. The P_L -map of Alpha has been utilised also for range simulations of Beta due to simplicity and with the assumption that the losses for the driver pattern in WLTC would be relatively close for the two machines. P , the machine power needed to generate the required torque, is the product of the machine torque and rotational speed according to the first equivalence in Equation (1). The rotational speed of the machine, ω_m , is determined by the means of the vehicle velocity. The machine torque, T_m , is calculated with Equation (6).

$$T_m = \begin{cases} \frac{F_D R}{i \eta_{tr}}, & \text{if driving,} \\ \frac{F_D R \eta_{tr}}{i}, & \text{if braking,} \end{cases} \quad (6)$$

where

F_D is the drive force [N],

R the wheel radius [m],

i the ratio between wheels and machine, and

η_{tr} the transmission efficiency [-].

The wheel radius is known, the value used in the calculations is the distance between the wheel centre and the touching point on the ground to give the actual circumference of the wheel in motion and not the circumference of an unloaded wheel. The ratio and transmission efficiency of the system are also known. The product $F_D R$ makes the wheel torque. The drive force represents the force needed to push the car forward in the desired speed. It is a function of the vehicle velocity and has been calculated with Equation (7).

$$F_D = \frac{1}{2} C_D A \rho v^2 + m g f_R b + (m + m_D) a, \quad (7)$$

where

C_D is the drag coefficient [-],

A the frontal area [m²],

ρ the density of air [kg/m³],

v the vehicle velocity [m/s],

m the vehicle mass [kg],

g the gravity of Earth [m/s²],

f_R the rolling resistance coefficient [-],

$$b = \begin{cases} 0, & \text{if } v = 0 \\ 1, & \text{if } v > 0 \end{cases}$$

m_D the vehicle dynamic mass [kg], and

a the vehicle acceleration [m/s²].

The first term in Equation (7) describes the drag [105], the second the rolling resistance [106] where function b [107] indicates that it is only considered when the vehicle is in motion, and the third the net force according to Newton's second law [103]. As can be seen in the equation, the first factor in the net force consists of two contributors; the mass of the vehicle and the dynamic mass of the vehicle which is related to the inertia of the rotating parts in the system. Both these masses are known. Further are the drag coefficient, the frontal area, the density of air, the gravity of Earth, and the rolling resistance known parameters. The velocity and the acceleration, which is the derivative of the velocity, follow the WLTC.

5.4.3 Acceleration

Acceleration times for 0-100 km/h have been estimated for 11:an, with both Alpha and Beta, as well as for Polestar 2 with its existing machines. The aim is to compare

the systems and to see whether the machines considered for 11:an are powerful enough. The procedure and set of equations for the acceleration calculations are proposed by technical specialist Bengt Noren [104]. Newton's second law have been used to calculate the acceleration [103]. Here the acceleration, a , has been converted to $\frac{dv}{dt}$ according to Equation (8). As can be seen in the equation, the total mass is the sum of the vehicle mass and the dynamic mass related to the inertia of the rotating parts in the system.

$$(m + m_D)a = F \Rightarrow (m + m_D)\frac{dv}{dt} = F \Rightarrow dv = \frac{F}{m + m_D}dt, \quad (8)$$

where

m is the vehicle mass [kg],
 m_D the dynamic mass [kg],
 a the vehicle acceleration [m/s^2],
 F the net force [N],
 v the vehicle velocity [m/s], and
 t the time [s].

The vehicle mass and the dynamic mass are known and the time step dt has been set to 10 ms. Iterations are done for each time step until 100 km/h is reached. The sum of the time steps make the total acceleration time. The net force has been determined with Equation (9).

$$F = T_m \frac{i}{R} \eta_{tr} - \frac{1}{2} C_D A \rho v^2 - mg f_R, \quad (9)$$

where

T_m is the machine torque [Nm],
 i the total ratio between wheels and machine [-],
 R the wheel radius [m],
 η_{tr} the transmission efficiency [-],
 C_D the drag coefficient [-],
 A the frontal area [m^2],
 ρ the density of air [kg/m^3],
 g the gravity of Earth [m/s^2], and
 f_R the rolling resistance coefficient [-].

The first term in the equation describes the force delivered from the machine [104], the second the drag [105], and the third the rolling resistance [106]. The ratio, wheel radius, transmission efficiency, drag coefficient, frontal area, air density, vehicle mass, gravity of Earth, and rolling resistance coefficient are known. The velocity is increased for every time step in the iterating loop according to Equation (8). The machine torque is a function of the rotational speed, ω , and the voltage, U . Every machine has their own characteristics. For simplicity constant voltage is assumed here, hence the machine torque is a function of the rotational speed, which in turn is determined as

$$\omega = v \frac{i}{R}, [\text{rad/s}]. \quad (10)$$

Here the rotational speed is given in the SI derived unit rad/s. The machine torque was extracted from a predefined table of data where the input parameter rotational speed is given in revolutions per minute (rpm). Therefore, the constant $\frac{30}{\pi}$ is added to convert the rotational speed from rad/s to rpm, hence it can be denoted n and be expressed as

$$n = \omega \frac{30}{\pi}, [\text{rpm}]. \quad (11)$$

5.5 Cost and Weight Estimations

In addition to range and acceleration, the layout of 11:an has been compared to the propulsion layout of Polestar 2 in terms of cost and weight. Thus, the two layouts have been evaluated in a cost- and weight- analysis. The comparison has been conducted on a component level, followed by an investigation of how the component cost and weight contributes to the total propulsion system cost and weight. The categories which the analysis include are *Machine(s)*, *Inverter(s)*, *Transmission Elements*, *Battery Pack* and *Total Cost/Weight*. The actual data on cost and weight are confidential and has been acquired through internal sources such as consultation with technical experts. Thus, the cost and weight of 11:an are presented in relation to those of Polestar 2. To enable a fair comparison all components and subsystems have been set up in the same manner, e.g. including housing. Moreover the cost and weight of the battery pack of the two propulsion layouts have been estimated as identical.

5.5.1 Cost Estimation

Starting with the cost estimation, the total cost of the propulsion layout of Polestar 2 has been expressed as X . Moreover the cost of the machines is denoted x_1 , inverters x_2 , transmission elements x_3 and battery pack x_4 . Hence, the total cost of the Polestar 2 propulsion system has been calculated using Equation (12).

$$X = x_1 + x_2 + x_3 + x_4, \quad (12)$$

As for the total cost of the layout of 11:an, it has been calculated in a similar manner through estimations of the cost of the individual components. The cost of the machines of Polestar 2 and Beta, have been assessed through the help of cost engineering experts at VCG. Thus the cost of Beta is based on the machines of Polestar 2, with altered dimensions. When assessing the cost of the new inverter, it was estimated to be around 85% of the combined cost of the two inverters of Polestar 2. The reason for which being the need for a higher level of capacity inverter compared to what is available within automotive today, to be able to sustain Beta. To relate the cost of 11:an with the propulsion layout of Polestar 2, the ratio has

been obtained by dividing the component- and total- costs of the propulsion layouts. The results of the cost estimations are presented within Chapter 6.2.3.

5.5.2 Weight Estimation

As for the weight estimation, it has been conducted similarly to the cost assessment. The total weight of the Polestar 2 propulsion layout has been denoted Y , while the weight of the machines is denoted y_1 , inverters y_2 , transmission elements y_3 and battery pack y_4 . Thus, the total weight of the propulsion system of Polestar 2 is calculated using Equation (13).

$$Y = y_1 + y_2 + y_3 + y_4, \quad (13)$$

Regarding the weight of 11:an, it has been calculated in a similar manner. As for the new machine, Beta, its mass has been calculated by scaling the mass of the Alpha machine, which was done based on the volume ratio of the two machines. By multiplying the mass of Alpha with the volume ratio between said machine and Beta, the mass of Beta was obtained. Moreover, the increased capacity inverter required to match such a machine, has been estimated to weigh 90 % of the combined weight of the two inverters of Polestar 2. This because combining the capacity of the two inverters within a single housing, would eliminate the need for all the walls of the housing and thus result in a reduced total weight. Finally, the propulsion system cost of 11:an has been calculated in relation to the one of Polestar 2. The results of the weight estimation is presented in Chapter 6.2.3.

5.6 Sensitivity Analysis

To account for uncertainties, a sensitivity analysis has been carried out on certain aspects of the project. E.g. an investigation of the robustness of the performance results (acceleration and range) with the chosen machine dimensions, has been conducted. Accordingly the range and acceleration simulations have been subjected to the machine specifications of the different machine dimensions presented in Section 5.4.1. In addition, the weight of all machines have been calculated. The heaviest and the lightest machines have been accounted for in an uncertainty check of the results of the weight analysis.

Furthermore, the possible future expansion of the 400 V system to a 800 V system and its impact on the alternative propulsion layout has been assessed and is further discussed in Chapter 7.

6

Final Evaluation

The purpose of this chapter is to indulge the reader in the evaluation of the final architectural design of the developed alternative propulsion layout, 11:an, compared to Polestar 2. Initially an illustration including a conceptual model of the final components and subsystems, dimensions and positions, as well the overall layout of 11:an is presented. Furthermore, the comparison between 11:an and the mainstream standard layout, represented by Polestar 2, is given to point out similarities and differences between the two. How 11:an performs on range and acceleration compared to Polestar 2 is evaluated, followed by how efficient it is in terms of cost and weight. This comparison constitutes the foundation on which the discussion of the alternative propulsion layout is based.

6.1 11:an Propulsion Layout

In Figure 18 the final architectural design of the alternative propulsion layout is illustrated at a conceptual level. Based on the results from the literature study and consultation with technical experts, the variants of components were chosen, followed by their positioning and dimensions as presented in Chapter 5.3.

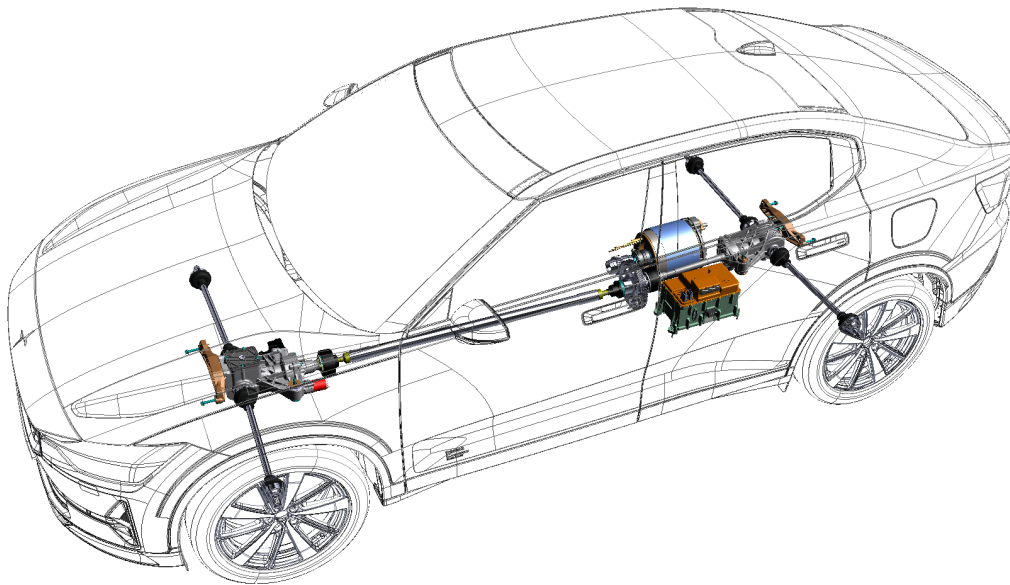

Figure 18: Final Architectural Design. The final architectural design of the alternative propulsion layout. Modelled by Lars Stenvall [70].

6.2 Comparison with Polestar 2

To be able to reach a conclusion on whether 11:an is a more efficient propulsion layout than the one of Polestar 2, from a cost- and weight- perspective, the two layouts have been compared with equal performance levels for range and acceleration. Initially a comparison of the architectural design is presented, followed by fulfilment of performance requirements and results on the cost- and weight- analysis.

6.2.1 Architectural Design

A comparison of the overall architecture of the two layouts on a conceptual level, is presented in Figure 19. The wheelbase measurements and drive shafts of the two layouts are assumed identical. One of the major differences is the propeller shaft included in the alternative propulsion system layout. Moreover it utilises a lesser number of machines and inverters compared to Polestar 2. The positioning and placement of the machines and inverters differ too, as the machines are placed coaxial the wheel axles in Polestar 2, while the machine of the alternative layout is placed parallel the propeller shaft and driving course. The inverters are placed offset the machines in both layouts.

The fixed gear transmission between the machine and the propeller shaft differ from the one between the machines and wheel axles in Polestar 2, because of the different machine installations. Moreover, the alternative layout requires the use of a FDU and RDU respectively to transfer the power to the wheels, while such a function is integrated in the EFAD and ERAD of Polestar 2. As for the battery pack, its installation in the alternative layout will be affected by the propeller shaft and will thus differ from the battery pack installation of Polestar 2.

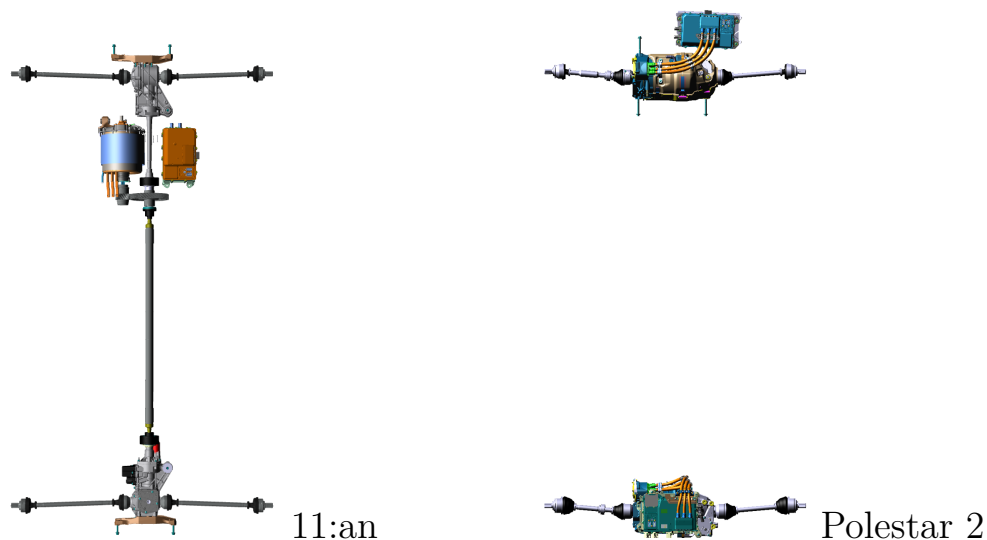

Figure 19: Propulsion Layout Comparison. The propulsion system layout of Polestar 2 and 11:an in comparison. The top of the picture represents the rear of the car. Modelled by Lars Stenvall [70].

6.2.2 Performance Requirement Fulfilment

The system layout of 11:an has a sufficient performance level based on the calculations. In order for the cost and weight comparisons with Polestar 2 to be fair, 11:an should have accurate capacity in terms of range and acceleration. Thus, the results should be within the interval of the target value $\pm 5\%$. The target value is here the level of Polestar 2.

Based on Equations (3)-(7) the range for 11:an is 0.4% longer than Polestar 2. Hence, 11:an has a slightly better range than the reference and is within the target margin of the tighter tolerance interval stated in the requirements specification, see Table 5.

According to Equations (8)-(10) the acceleration time from 0 to 100 km/h is 4.43 and 4.30s for 11:an and Polestar 2 respectively. Thus, the estimated acceleration time for 11:an is 3% longer than the target value, the acceleration time of Polestar 2. To put it into context of the requirements specification it does not fulfil the desired tighter tolerances, yet it is within the required target interval.

6.2.3 Cost and Weight Analysis

The result of the cost- and weight- calculations of 11:an in relation to the layout of Polestar 2, presented in Chapter 5.5, can be found in Table 6 and 7 respectively. Analysing the total cost- and weight- results, based on the components included in the assessment, the layout of 11:an is both lighter and costs less than the one of Polestar 2. It costs roughly 4% less and it weighs circa 3% less than the Polestar 2 layout, which corresponds to a weight reduction of around 21 kg. Keeping in mind that other systems related to the propulsion layout, such as cooling systems and charging, might be affected by the way the propulsion system of 11:an is laid out. Thus, the total cost and weight could vary slightly. This is further discussed in Chapter 7.

Table 6: Cost Results. Showing the cost of the alternative propulsion layout expressed as a proportion of the cost of the propulsion layout of Polestar 2. X representing the total cost, x_1 the cost of the machines, x_2 the cost of the inverters, x_3 the transmission cost and x_4 the cost of the battery pack.

Cost Results - Alternative Propulsion Layout				
Machine	Inverter	Transmission Elements	Battery Pack	Total
$0.63x_1$	$0.85x_2$	$1.23x_3$	$1x_4$	$0.96X$

As the number of machines is reduced in the new layout, an induced lower weight and cost was assumed. However, it was unclear if and by how much these aspects would be improved. Starting with the component comparison, the cost and weight

Table 7: Weight Results. Showing the weight of the alternative propulsion layout expressed as a proportion of the weight of the propulsion layout of Polestar 2. Y representing the total weight, y_1 the weight of the machines, y_2 the weight of the inverters, y_3 the transmission weight and y_4 the weight of the battery pack.

Weight Results - Alternative Propulsion Layout				
Machine	Inverter	Transmission Elements	Battery Pack	Total
$0.68y_1$	$0.90y_2$	$1.30y_3$	$1y_4$	$0.97Y$

comparison with the corresponding Polestar 2 components is found in Figure 20 and 21. As can be seen, the machine cost of 11:an is reduced by 37% while its weight is reduced by 32%, compared to the machines of Polestar 2. Compared to the total cost of the Polestar 2 inverters, the resulting cost reduction of the inverter of 11:an corresponds to 15%. Similarly, the weight of the up-sized inverter was assumed to make up 90% of the weight of the Polestar 2 inverters, resulting in a weight reduction of 10%.

Regarding the transmission elements, their cost and weight in the layout of 11:an was expected to increase as the propeller shaft, FDU and RDU was added. Accordingly, the cost of the transmission elements in 11:an constitutes an increase of 23% compared to the transmission elements of Polestar 2. In total the transmission elements of 11:an weigh 30% more compared to the transmission components in Polestar 2, currently constituting the only component or subsystem whose cost and weight increases with 11:an. As for the battery pack, its cost and weight has been estimated the same for the two propulsion layouts, as previously stated.

In Figure 22, the cost walk of 11:an is presented, showing how the components contribute to the reduction of the overall propulsion system cost. Similarly, the weight distribution of 11:an is presented in Figure 23, showing the component contribution to the overall propulsion system weight. As can be seen, the total cost reduction with 11:an constitutes 4%, while the weight reduction is 3% which corresponding to 21 kg. The machine, Beta, is the component that contributes most to the reduction of the total propulsion system cost and weight. It lowers the total cost of the system with 3%, while it reduces the cost with 6%. The inverter cost of 11:an reduces the total propulsion system cost with 2%, while its weight does not contribute much to the overall propulsion weight. As for the transmission elements of 11:an, they increase the total propulsion system cost and weight with 1% and 3% respectively. Lastly, the cost and weight of the battery pack is assumed the same for both layouts. Thus, the cost and weight of the battery pack appears to not contribute much to the propulsion system. However, any changes to the battery pack will contribute to the cost and weight of the overall system as it is the largest part of the propulsion system.

The result of the uncertainty analysis of the machine weight, presented in Chapter 5.6, constitutes a total machine weight reduction span of 23 – 47% compared to machines of Polestar 2. As for the total propulsion weight of 11:an compared to

Polestar 2, the weight reduction spans from 1 – 6% analysing the heaviest and the lightest machines presented in Chapter 5.4.1. Thus, using Beta as the machine of 11:an, both the comparison on machine and total weight reduction lies in the middle of the two spans presented.

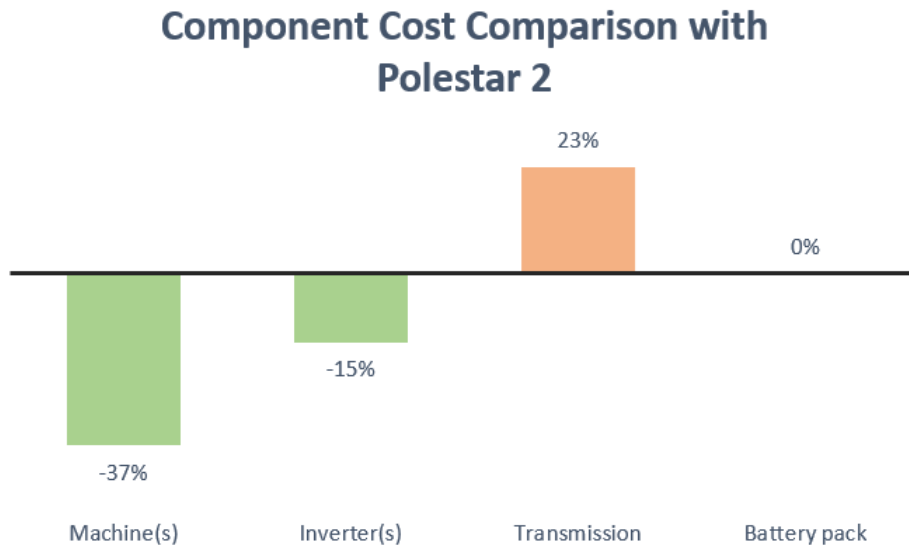

Figure 20: Component Cost Comparison with Polestar 2. Graph showing the cost of the components of 11:an in relation to the corresponding components in the layout of Polestar 2. [Own Illustration].

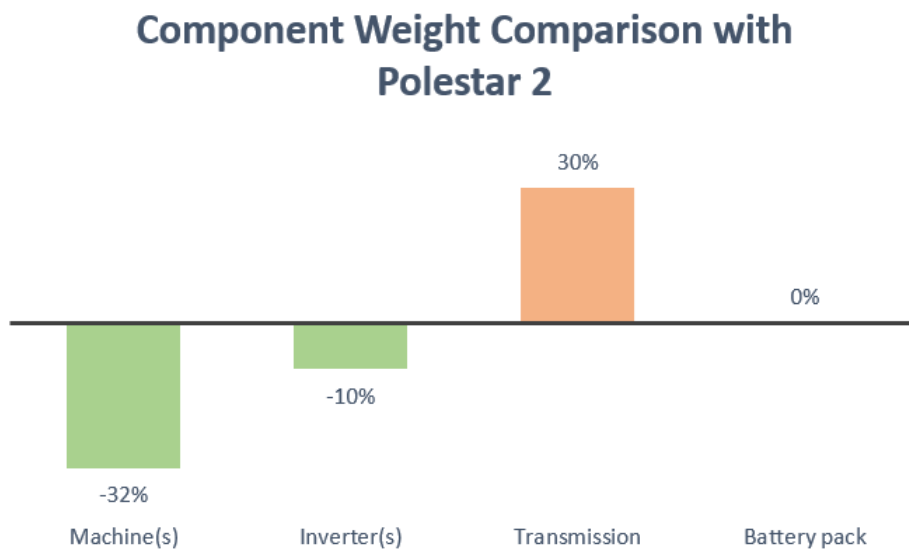

Figure 21: Component Weight Comparison with Polestar 2. Graph showing the weight of the components of 11:an in relation to the corresponding components in the layout of Polestar 2. [Own Illustration].

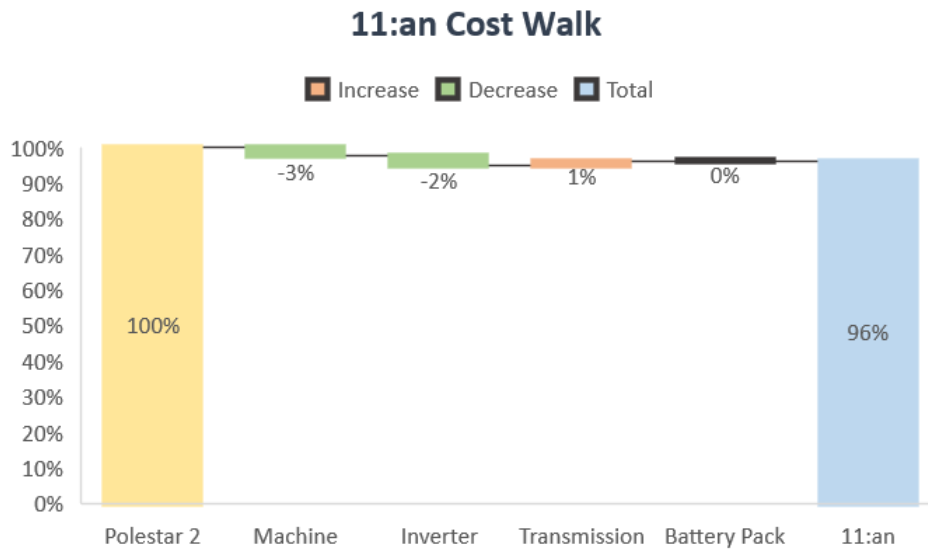

Figure 22: Cost Walk of 11:an. Graph showing the cost walk of 11:an comparing the component cost in relation to the overall layout of Polestar 2. [Own illustration].

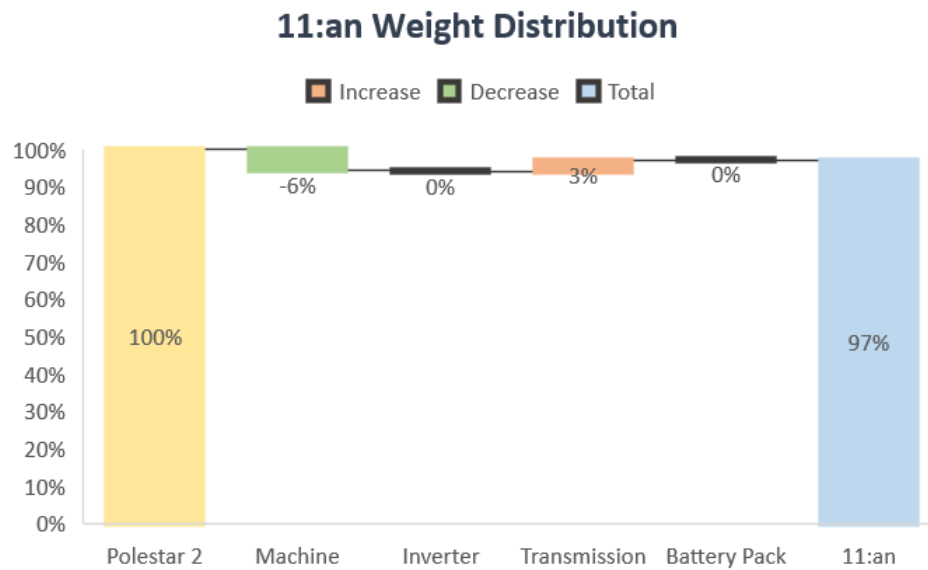

Figure 23: Weight Distribution of 11:an. Graph showing the weight distribution of 11:an comparing the component cost in relation to the overall layout of Polestar 2. [Own illustration].

7

Discussion

In the following chapter the results of the study, as well as the utilisation of methodology, are critically discussed with the aim of illuminating important aspects and trade-offs related to this project. Moreover, the purpose of which is to provide the reader with knowledge to better understand the reasoning behind the conclusions and recommendations presented in Chapter 8. Advantages and drawbacks of the alternative propulsion layout are discussed based on the comparison between it and Polestar 2 featured in Chapter 6.2. Further on the methods used in this study and why, are discussed and criticised. Lastly, this chapter is wrapped up by addressing sustainable aspects regarding the project, focusing on BEVs in general. Environmental-, economical- and social aspects of sustainability are discussed.

7.1 Alternative Propulsion Layout

The main advantage of the alternative propulsion layout is the decrease in number of machines and inverters. It results in a decrease in both cost and weight, which are vital factors in the the automotive industry. The new layout does not only have a decreased number of components, but is also enabling a change of position of the machine, which may open new possibilities of how to create BEV architectures. The machine position in Polestar 2 implies machine dimension limits in terms of diameter and length of the machine because of its coaxial installation on the drive axle. The layout of 11an is permitting a bigger machine volume.

It should also be noted that 11:an showed a slightly slower acceleration compared to Polestar 2. Instead, the results indicated a somewhat increased range with 11:an. Like so, increasing the total gear ratio should result in a faster acceleration. Though the weight of the transmission elements would likely increase, which could contribute to a shorter range.

The implementation of a propeller shaft has both positive and negative aspects. For OEMs, such as Volvo Cars, that are producing combustion cars it can be a cost saver as the knowledge and technology already exist within the company. A propeller shaft already being in production can be modified and implemented in a new BEV. Using an old reliable technology signifies that the TRL is high and the investment cost is low, which is important to consider.

Adding a propeller shaft, however, also comes with some problems. As it is a rotating part the propeller shaft will contribute to an increased dynamic mass. Typically, it is preferable to have a system with as few rotating parts as possible. Further, its position most likely hinders a flat floor interior design in the rear seat area, thus the bump in the middle existing in today's Volvo cars will remain. Moreover there will be an impact on the battery pack as the propeller shaft goes where the battery is located in Polestar 2, hence some battery modules would have to be moved. Also a propeller shaft might impact the NVH in the vehicle.

Another interesting aspect is the possible shift of the centre of gravity. Considering the new layout opens up many packing options with a high degree of freedom of where to place the system components the centre of gravity may be elaborated.

It is however important to emphasise that only some propulsion components have been investigated in this thesis. Many other components and systems will be effected in a positive or negative way. With a lower weight a decrease in required battery size may be possible. With fewer components the complexity of the propulsion system is decreased. That in combination with an increased possibility to affect their positions, shorter cables may be possible, which has a positive effect on cable weight. With an increase in machine size its cooling system may need to be increased more than linearly. Consequently resulting in a possible increased weight of the cooling system.

7.2 Goal Fulfilment

As for the goals and deliverables set for this project, the process followed to perform the literature study and the benchmark enabled identification of the premium BEV standard propulsion layout. Moreover, the layout of Polestar 2 was identified to follow the same standard layout and can thus be argued a suitable reference to compare the layout of 11:an with. Regarding the question as to why the standard propulsion system is laid out with two motors instead of one larger and more powerful alternative, seems to be answered when analysing the benchmark results.

Many OEMs seem to follow leading actor Tesla when it comes to the technological aspects of how the architectural design of the BEV propulsion system is laid out. Since Tesla have been producing BEVs from scratch and not having to adapt their conventional ICE vehicles to an electric platform, they have the advantage of adapting surrounding systems to the electric propulsion layout instead of having to do it the other way around like most OEMs. Hence, the two-machine-solution has been considered best practice.

Due to the time limit of the project, in combination with an extended time required to complete the dimensioning phase, not as many iteration loops of the calculations were performed as was originally planned. A possible reason for which being the amount of time required to gather the input data, as many stakeholders had to be

contacted. Nevertheless, all planned deliveries were achieved within the time frame of the project. 11:an was realised and analysed in terms of performance, cost and weight. Furthermore it was evaluated in comparison to Polestar 2 and the level of fulfilment of the requirements specification.

7.3 Validity

A difficulty with performing a benchmark of several competitors is to make a fair and comprehensible comparison. When comparing data from different sources it is important to be aware of the fact that the "same" measurement can be defined differently at different sources. And the definitions are not always to be found. Further, sometimes the figures can be rounded off in the most beneficial way to the company publishing them, hence they must be viewed with a critical eye.

When comparing the *weight* the vehicle load must be taken into consideration. There are different load conditions, e.g. if all liquids such as windscreen washer fluid are at maximum level, if the driver and any passengers are included, or if additional load is included. The masses calculated with in this project has been the curb weight plus 100 kg representing the driver.

The *range* of a BEV for instance, depends on many parameters, such as speed, load, outdoor temperature, and use of electrically driven equipment in the coupé [108], [109]. When determining which range a certain car model can achieve with a fully charged battery a set test drive cycle is used. There exist a large number of official drive cycles [108]. Making a comparison of car models that have been tested in different drive cycles with different settings would prevent a fair judgement.

Considering the fact that there are not a huge amount of commercial EV models out on the roads yet, it is of interest for the the benchmark to include announced upcoming ones as well. Comparing these with the already existing ones would not be fair though, as the data available almost exclusively comes from the OEMs themselves stating that they aim to reach a certain range etc. What the actual range will be cannot be judged before a prototype of the final car is produced. Investigating which models are introduced in the market in the near future has certainly been of high interest when mapping up the EV environment.

The calculation methods used have been simplified with regards to several factors. This can for example be seen in the result of the acceleration time, which is a bit lower than the official data given by Polestar. However, as the range and acceleration time has been made as comparisons between 11:an and Polestar 2 the results may still be accurate enough to tell if the two systems are at an equal level. By using the same methods and simplifications when calculating range and acceleration both the systems have been treated the same. An example is the charging losses that have not been considered here. They are typically not big enough to make a significant impact on the result.

Also the comparisons of the efficiency in terms of cost and weight have been done in the same way for both the layouts, hence the results can be compared. When assessing the propulsion system cost and weight of both of Polestar 2 and 11:an, the values have been obtained through a variety of sources, which constitutes a possible source of error as they affect the results differently. As a way of compensating for the possible errors the calculations have been performed using conservative estimations of the obtained values.

It is also of importance to consider the background of the students performing this study being mechanical engineering. As an extensive part of the project involves the dimensioning of the electric machine, certain assumptions and simplifications have been made in order to achieve a feasible result within the given time frame. However, the methods utilised when performing the dimensioning along with the product itself being a propulsion system, made the project suitable for a background within mechanical engineering.

Since there is no single inverter utilised within automotive today that provides the capacity needed to sustain the Beta machine, the TRL of the concept is questionable. Nevertheless, in short term this can be avoided by connecting two inverters to each end of the machine, which would induce an increased weight. Currently the standard voltage system of the BEV constitutes 400 V. However, there is a possibility of that system being extended to 800 V in the future [110]. In such a situation it is of interest to evaluate how the layout of 11:an would be affected. The 800 V system would enable a high power output without having to increase the amount of current that is required with today's 400 V system. Thus, it would reduce the need for larger cables with an increased diameter, to be able to transport a sufficient amount of current within the system. Consequently, the possible future change to such a system would serve in favour of the concept of 11:an.

7.4 Reflection on Sustainability

Will EVs be a sustainable alternative for transportation? One of the main drivers for EVs is the climate change and accordingly the initiatives to find means of transportation generating less CO₂ emissions. In the user phase an EV produces less CO₂ emissions compared to an ICE vehicle. However, the production of an EV results in higher emissions. That means that an EV driven less than to the break even point has a greater impact on the environment [111].

Another important aspect when comparing ICE vehicles and BEVs is that the electricity can be more or less sustainable. Burning coal to generate electricity has a very negative environmental impact and generating electricity from renewable energy sources, e.g. wind, is a better alternative. Yet another aspect to keep in mind is that there are more environmental concerns than the climate change; e.g. resource depletion and human toxicity are factors to be taken into consideration when comparing different options.

From a company point of view the economic sustainability has a great importance. Moving from one technology to another requires investments that in time needs to be covered. In order to make BEVs an appealing option to as many people as possible the battery costs needs to be decreased, which also would result in lower prices for the end consumer. Since the layout of 11:an utilises a mechanical AWD system, which is a well known technology at VCG, the investment cost of such a system is relatively low for them compared to if e.g. Tesla would try to implement such a solution.

8

Conclusions and Recommendations

In the following chapter final conclusions are drawn from the execution of the project. Firstly, remarks on the results of the technology analysis and layout dimensioning are presented, followed by the methodology used. Moreover, recommendations regarding actions to take when developing the alternative layout further are submitted.

8.1 Conclusions

From the benchmark results it can be concluded that the industry standard of achieving AWD with a premium BEV, is through the use of two electric machines and two corresponding inverters connected to the battery pack. Tesla has been identified as the leading actor on the premium BEV market when it comes to technology, as other OEMs has been noted to follow the same propulsion system layout. Polestar 2 was confirmed as a reference representative of this industry standard layout. Moreover, Polestar 2 was identified as part of the *Medium/Large/Executive Cars* segment and was compared with Tesla Model 3 Long Range regarding performance and cost. The patent search showed little risk of infringement on existing solutions today.

The final machine dimensions of Beta in 11:an is comprised by a diameter of 260 mm and the active length of 195 mm which corresponds to a volume of around 10.4 dm³. It is placed parallel the ground and the propeller shaft with a fixed gear transmission installed between the two components. The corresponding up-sized inverter is placed on the other side of the propeller shaft.

Considering the results obtained from the acceleration- and range- simulations, while 11:an currently features a 3% slower acceleration capacity compared to Polestar 2, its range exceeds Polestar 2 with roughly 0.4% which is well within the margin of error. Thus, the requirements on performance are met as the final value lies within the 5% margin stated in the requirements specification.

Regarding cost and weight, the layout of 11:an shows a cost reduction of around 4% compared to the propulsion layout of Polestar 2, which fulfils the requirement identified when mapping Polestar 2. Moreover, the results of the weight analysis indicate a weight reduction of 3% with 11:an compared to the layout of Polestar 2,

which corresponds to roughly 21 kg. Thus, as the performance parameters of range and acceleration are comparable between Polestar 2 and 11:an, the new propulsion layout shows improved efficiency compared to the industry standard layout when it comes to both cost and weight.

8.2 Recommendations and Future Work

For further development of the alternative propulsion layout, the system boundary should successively be expanded to include other components relevant to the propulsion layout such as battery pack, cooling system and cabling. The first step would be to investigate the possibilities of adapting the battery pack to the alternative layout in terms of sizing and placement, followed by further iterations of range and acceleration simulations and calculations of cost and weight.

Also, considerations to be made include a more extensive analysis on packaging aspects when it comes to verification on positioning and placement of the components of the alternative propulsion layout. E.g. the modules in the battery pack need to be rearranged in order to fit the propeller shaft. At the same time there will be more space around the drive shafts which perhaps can be utilised.

Moreover, the implementation of a disconnect clutch in either the FDU or RDU should be considered to be able to disengage one of the wheel axles in driving modes when AWD is not required. This to make the energy usage more efficient and minimise losses.

Since the current system is 400 V, an increased amount of current required to sustain a more powerful machine would result in larger cables. Thus, if an increased amount of current is needed, the possibility of implementing a 800 V system should be investigated.

Furthermore, the possibility to implement other machine types, such as an axial flux machine, should be investigated to evaluate which is most efficient and powerful for the application.

References

- [1] European Commission, “Reducing CO2 emissions from passenger cars,” retrieved on 2019-03-22. [Online]. Available: https://ec.europa.eu/clima/policies/transport/vehicles/cars_en
- [2] M. J. Coren, “Nine countries say they’ll ban internal combustion engines. so far, it’s just words.” *Quartz*, 2018, retrieved on 2019-03-22. [Online]. Available: <https://qz.com/1341155/nine-countries-say-they-will-ban-internal-combustion-engines-none-have-a-law-to-do-so/>
- [3] M. Stjerna, “Toyota: ’elbilar måste bli överkomliga’,” *Teknikens Värld*, 2018, retrieved on 2019-03-22. [Online]. Available: <https://teknikensvarld.se/toyota-elbilar-maste-bli-overkomliga/>
- [4] Scania, “Electrification,” retrieved on 2019-04-04. [Online]. Available: <https://www.scania.com/group/en/electrification/>
- [5] L. S. Park, “Exciting cooperation for sustainable public transport,” retrieved on 2019-04-04. [Online]. Available: <https://www.electricitygoteborg.se/en>
- [6] M. Jenkins, “7 reasons why electric boats will be the best in the world,” *Medium*, 2017, retrieved on 2019-04-04. [Online]. Available: <https://medium.com/from-the-exosphere/7-reasons-why-electric-boats-will-be-the-best-in-the-world-8443758858a>
- [7] M. Ros, “7 electric aircraft you could be flying in soon,” *CNN travel*, 2017, retrieved on 2019-04-04. [Online]. Available: <https://edition.cnn.com/travel/article/electric-aircraft/index.html>
- [8] V. Cars, “This is volvo cars,” retrieved on 2018-08-28. [Online]. Available: <https://www.volvocars.com/uk/about/our-company/this-is-volvo-cars>
- [9] B. Hasselgren, “Volvo fyller år,” *BizStories*, 2017, retrieved on 2019-03-25. [Online]. Available: <https://naringslivshistoria.se/bizstories-nyheter/naringslivshistoria/volvo-fyller-ar/>
- [10] Volvo Car Sverige AB, “1927 - 2007 - 80 år med Volvo-bilar,” retrieved on 2019-03-25. [Online]. Available: <https://www.media.volvocars.com/se/sv-se/media/pressreleases/11209/1927-2007-80-r-med-volvo-bilar>
- [11] —, “Detta är Volvo,” retrieved on 2019-03-25. [Online]. Available: <https://www.media.volvocars.com/se/sv-se/corporate/this-is-volvo>
- [12] Volvo Car Corporation, “Volvo car Group,” retrieved on 2019-03-25. [Online]. Available: <https://group.volvocars.com/company>
- [13] Polestar, “Polestar,” retrieved on 2019-03-25. [Online]. Available: <https://www.polestar.com/>
- [14] Volvo Car Corporation, “Care by Volvo,” retrieved on 2019-03-25. [Online]. Available: <https://www.volvocars.com/intl/cars/care-by-volvo>

- [15] Zenuity AB, “Make it real,” retrieved on 2019-03-25. [Online]. Available: <https://www.zenuity.com/make-it-real/>
- [16] Volvo Car Mobility, “Move freely,” retrieved on 2019-03-25. [Online]. Available: <https://m.co/>
- [17] Lynk & Co International AB, “Lynk & Co,” retrieved on 2019-03-25. [Online]. Available: <https://www.lynkco.com/company>
- [18] R. Matulka, “The history of the electric car,” retrieved on 2019-02-13. [Online]. Available: <https://www.energy.gov/articles/history-electric-car>
- [19] C. J. Cleveland and C. Morris, “Dictionary of Energy,” retrieved on 2019-02-22. [Online]. Available: <https://www-sciencedirect-com.proxy.lib.chalmers.se/science/article/pii/B9780080968117500020>
- [20] G. Pistoia, “Automakers’ powertrain options for hybrid and electric vehicles,” *Electric and Hybrid Vehicles*, pp. 579 – 636, 2010, retrieved on 2019-02-22.
- [21] A. McEachern, “Hybrids: What is the difference between traditional and plug-in?” *Electric Vehicle News*, 2012, retrieved on 2019-02-26. [Online]. Available: <https://www.fleetcarma.com/hybrids-what-is-the-difference-between-traditional-and-plug-in/>
- [22] C. J. Cleveland and C. Morris, “Dictionary of energy,” retrieved on 2019-02-22. [Online]. Available: <https://www-sciencedirect-com.proxy.lib.chalmers.se/science/article/pii/B9780080968117500160#p2020>
- [23] Petter Lydén, “Räckviddsångest,” retrieved on 2019-04-01. [Online]. Available: <http://www.klimatordlista.se/rackviddsangest/>
- [24] E. Söderholm, “Räckviddsångest vanligast hos bilägare som inte har någon elbil,” *Recharge*, 2018, retrieved on 2019-04-01. [Online]. Available: <https://www.mestmotor.se/recharge/artiklar/nyheter/20170207/elbil-rackviddsangest/>
- [25] M. Mruzek, “Analysis of parameters influencing electric vehicle range,” *Procedia Engineering*, vol. 134, pp. 165 – 174, 2016, retrieved on 2019-04-05.
- [26] A. Moir, “Which factors impact an electric car’s driving range?” *Arnold Clark*, 2017, retrieved on 2019-04-15.
- [27] M. Bull, “Mass reduction performance of pev and phev vehicles,” *The Aluminum Association, Aluminum Transportation Group (ATG)*, 2011, retrieved on 2019-04-15.
- [28] WLTPfakta.se, “Övergångstidslinje: Från nedc till wltp,” retrieved on 2019-04-16. [Online]. Available: <http://wltpfakta.se/>
- [29] M. Stjerna, “Wltp: Törstigare bilar och kortare räckvidd,” *Teknikens Värld*, 2018, retrieved on 2019-04-01. [Online]. Available: <https://teknikensvarld.se/wltp-torstigare-bilar-och-kortare-rackvidd/>
- [30] M. Salutskij, “Elmotorn – så fungerar den,” *Teknikens Värld*, 2014, retrieved on 2019-03-25. [Online]. Available: <https://teknikensvarld.se/elmotorn-sa-fungerar-den-116707/>
- [31] drivteknik.nu, “Princip - Asynkronmotor,” retrieved on 2019-03-25. [Online]. Available: <http://www.drivteknik.nu/skolan/motor/asynkronmotor>
- [32] A. M. Andwari, A. Pesiridis, S. Rajoo, R. Martinez-Botas, and V. Esfahanian, “A review of battery electric vehicle technology and readiness levels,” *Renew-*

- able and Sustainable Energy Reviews*, vol. 78, pp. 414 – 430, 2017, retrieved on 2019-02-22.
- [33] T. Blomhäll, “Så fungerar motorn i elbilar,” *Elbilsskolan*, 2016, retrieved on 2019-02-25. [Online]. Available: <https://www.mestmotor.se/recharge/artiklar/artiklar/20160927/elbilsskolan-sa-fungerar-motorn-i-elbilar/>
- [34] J. Jenkins, “A closer look at switched reluctance motors,” *Charged*, 2013, retrieved on 2019-03-25. [Online]. Available: <https://chargedevs.com/features/a-closer-look-at-switched-reluctance-motors/>
- [35] drivteknik.nu, “Princip - Synkronmotor,” retrieved on 2019-03-25. [Online]. Available: <http://www.drivteknik.nu/skolan/motor/synkronmotor>
- [36] A. G. Gonzalez, “Magnet losses in inverter-fed high-speed pm machines,” Master Thesis, Royal Institute of Technology, 2015.
- [37] A. K. Rajvanshi, “Nikola tesla – the creator of the electric age,” *Resonance*, vol. 12, pp. 4 – 12, 2007, retrieved on 2019-02-27.
- [38] L. Engineering, “How does an electric car work? | tesla model s,” retrieved on 2019-02-05. [Online]. Available: <https://www.youtube.com/watch?v=3SAxXUIre28>
- [39] H. S. P. Explained, “Ac and induction motors explained,” retrieved on 2019-03-25. [Online]. Available: <https://www.youtube.com/watch?v=urfpZo1j9yI>
- [40] A. Cavagnino, M. Lazzari, F. Profumo, and A. Tenconi, “A comparison between the axial flux and the radial flux structures for pm synchronous motors,” *IEEE Transactions on Industry Applications*, vol. 38, pp. 1517 – 1524, 2002, retrieved on 2019-05-22.
- [41] Magnax, “The technology: Next-gen axial flux machines,” retrieved on 2019-05-22. [Online]. Available: <https://www.magnax.com/technology>
- [42] D. Moreels, “Axial flux vs radial flux: 4 reasons why axial flux machines have a higher power density,” retrieved on 2019-05-22. [Online]. Available: <https://www.magnax.com/magnax-blog/axial-flux-vs-radial-flux.-4-reasons-why-does-axial-flux-machines-deliver-a-higher-power-density>
- [43] T. Blomhäll, “Så fungerar växelriktaren i elbilar,” *Elbilsskolan*, 2016, retrieved on 2019-02-25. [Online]. Available: <https://www.mestmotor.se/recharge/artiklar/artiklar/20160927/elbilsskolan-sa-fungerar-motorn-i-elbilar/>
- [44] Danfoss, “Electric traction inverter (HEV/EV),” retrieved on 2019-04-05. [Online]. Available: <https://www.danfoss.com/en/markets/automotive/dsp/electric-traction-inverter-hevev/#tab-overview>
- [45] A. Sorniotti, S. Subramanyan, A. Turner, C. Cavallino, F. Viotto, and S. Bertolotto, “Selection of the optimal gearbox layout for an electric vehicle,” *SAE Int. J. Engines*, vol. 4(1), pp. 1267 – 1280, 2011, retrieved on 2019-03-05.
- [46] P. Gareffa, “Awd vs. 4wd: What’s the difference?” *edmunds*, 2018, retrieved on 2019-04-10. [Online]. Available: <https://www.edmunds.com/car-buying/awd-vs-4wd-whats-the-difference-and-which-to-choose.html>
- [47] x engineer, “Types of four-wheel drive (4wd) and all-wheel drive (awd) systems,” *AWD Technologies*, 2019, retrieved on 2019-04-10. [Online]. Available: <https://x-engineer.org/automotive-engineering/drivetrain/awd-technologies/types-four-wheel-drive-4wd-all-wheel-drive-awd-systems/>

- [48] what-when how, “Propeller shaft and drive shaft (automobile),” retrieved on 2019-04-15. [Online]. Available: <http://what-when-how.com/automobile/propeller-shaft-and-drive-shaft-automobile/>
- [49] K. Lacey, “Driveshaft angles: Why they matter and how to keep them in check,” retrieved on 2019-04-25. [Online]. Available: <https://www.chevyhardcore.com/tech-stories/chassis-safety/driveshaft-angles-why-they-matter-and-how-to-keep-them-in-check/>
- [50] G. Motions, “The fundamentals of planetary gear systems,” retrieved on 2019-04-15. [Online]. Available: <https://gearmotions.com/fundamentals-planetary-gear-systems/>
- [51] K. S. Gears, “Types of gears,” retrieved on 2019-04-16. [Online]. Available: https://khkgears.net/new/gear_knowledge/introduction_to_gears/types_of_gears.html
- [52] H. S. Works, “How gears work,” retrieved on 2019-04-16. [Online]. Available: <https://science.howstuffworks.com/transport/engines-equipment/gear4.htm>
- [53] Wikipedia, “Bevel gear,” retrieved on 2019-05-03. [Online]. Available: https://en.wikipedia.org/wiki/Bevel_gear
- [54] —, “Epicyclic gearing,” retrieved on 2019-05-03. [Online]. Available: https://en.wikipedia.org/wiki/Epicyclic_gearing
- [55] R. Biermann, “Tech talk – what are differentials?” *Torquing Cars*, 2017, retrieved on 2019-05-22.
- [56] W. Commons, “File:differential (manual of driving and maintenance).jpg,” retrieved on 2019-05-22. [Online]. Available: [https://commons.wikimedia.org/wiki/File:Differential_\(Manual_of_Driving_and_Maintenance\).jpg](https://commons.wikimedia.org/wiki/File:Differential_(Manual_of_Driving_and_Maintenance).jpg)
- [57] T. F. D. by Farlex, “Clutch,” retrieved on 2019-04-25. [Online]. Available: <https://www.thefreedictionary.com/clutch>
- [58] M. Di Russo, J. Ku, and J. Briones Idrovo, “Control development for an engine-disconnect clutch in a pre-transmission parallel hybrid electric vehicle,” *SAE International*, 2016, retrieved on 2019-03-08.
- [59] T. Blomhäll, “Så fungerar batterierna i elbilar,” *Elbilsskolan*, 2016, retrieved on 2019-02-25. [Online]. Available: <https://www.mestmotor.se/recharge/artiklar/artiklar/20160927/elbilsskolan-sa-fungerar-motorn-i-elbilar/>
- [60] O. Isaksson, “Strategic technology planning and development,” lecture in Product planning PPU085, Chalmers University of Technology. 2017-11-08.
- [61] Krita, “Krita desktop,” retrieved on 2019-05-25. [Online]. Available: <https://krita.org/en/>
- [62] K. Otto and K. Wood, *Product Design - Techniques in Reverse Engineering and New Product Development*. Prentice-Hall, Upper Saddle River, Ne Jersey, 2000, retrieved 2017 on lecture with Prof. Johan Malmqvist.
- [63] A2Mac1, “Your global partner for benchmarking,” retrieved on 2019-04-05. [Online]. Available: <https://portal.a2mac1.com/?redirect=%3Ffromredirect>
- [64] Caresoft, “Automotive,” retrieved on 2019-04-05. [Online]. Available: <https://www.caresoftglobal.com/automotive.html>
- [65] Microsoft, retrieved on 2019-05-25. [Online]. Available: <https://www.microsoft.com/sv-se/>

-
- [66] E. Haldorson, “Patent searching and analysis: I,” 2016, lecture, Chalmers University of Technology.
- [67] Espacenet, “Patent search,” retrieved on 2019-05-27. [Online]. Available: <https://worldwide.espacenet.com/>
- [68] P. L. Almfelt, “Requirements management with product innovation in mind,” 2018, lecture, Chalmers University of Technology.
- [69] MathWorks, “Math. graphics. programming.” retrieved on 2019-05-25. [Online]. Available: <https://www.mathworks.com/products/matlab.html>
- [70] L. Stenvall, “Cad renderings,” 2019, polestar.
- [71] UPTO, “Bmw i3,” retrieved on 2019-05-22. [Online]. Available: <https://www.upto.ch/en/product/bmw-i3/>
- [72] Tesla, “Designa din Model 3,” retrieved on 2019-03-19. [Online]. Available: https://www.tesla.com/sv_SE/model3/design#battery
- [73] Y. Motor, “Mercedes-benz eqc 2019 400 4matic,” retrieved on 2019-05-22. [Online]. Available: <https://uae.yallamotor.com/new-cars/mercedes-benz/eqc/400-4matic>
- [74] O. Krueger, “Högspänning,” *Teknikens Värld*, vol. 20, 2018, retrieved on 2019-03-21.
- [75] Chevrolet, “Bolt EV,” retrieved on 2019-03-22. [Online]. Available: <https://www.chevrolet.com/electric/bolt-ev-electric-car/build-and-price/features/trims/table?section=Highlights&styleOne=399469>
- [76] Polestar, “Polestar 2,” retrieved on 2019-03-26. [Online]. Available: <https://www.polestar.com/se/cars/polestar-2>
- [77] —, “Polestar 2 Konfigurator,” retrieved on 2019-05-02. [Online]. Available: https://www.polestar.com/se/polestar-2/configurator/534EDPI1E00070700RF8000_00000__R14B#summary
- [78] Tesla, “Designa din Model S,” retrieved on 2019-03-19. [Online]. Available: https://www.tesla.com/sv_SE/models/design
- [79] E. Wedberg, “Allemans-teslan,” *Teknikens Värld*, vol. 21, 2018, retrieved on 2019-03-14.
- [80] L. P. et al., “Nästa steg i evolutionen?” *Teknikens Värld*, vol. 26, 2018, retrieved on 2019-03-21.
- [81] Jaguar, “I-Pace Detaljer,” retrieved on 2019-03-22. [Online]. Available: <https://www.jaguar.se/i-pace>
- [82] Hedin Bil, “Jaguar I-Pace,” retrieved on 2019-03-22. [Online]. Available: <https://www.hedinbil.se/bilar/446897>
- [83] Mercedes-Benz, “The new Mercedes-Benz EQC,” retrieved on 2019-03-19. [Online]. Available: <https://tveassetsprod.blob.core.windows.net/editorial/2018/09/mercedes-eqc-400-4matic.pdf>
- [84] Electric Vehicle Database, “Mercedes EQC 400 4MATIC,” retrieved on 2019-03-22. [Online]. Available: <https://ev-database.uk/car/1135/Mercedes-EQC-400-4MATIC>
- [85] Tesla, “Designa din Model X,” retrieved on 2019-03-19. [Online]. Available: https://www.tesla.com/sv_SE/modelx/design
- [86] —, “Designa din Model Y,” retrieved on 2019-03-19. [Online]. Available: https://www.tesla.com/sv_SE/modely/design#battery

- [87] Tesla, “Tesla,” retrieved on 2019-04-03. [Online]. Available: <https://www.tesla.com/>
- [88] —, “MODEL S OWNER’S MANUAL,” retrieved on 2019-03-19. [Online]. Available: https://www.tesla.com/sites/default/files/model_s_owners_manual_north_america_en_us.pdf
- [89] Tesla, “MODEL X OWNER’S MANUAL,” retrieved on 2019-03-19. [Online]. Available: https://www.tesla.com/sites/default/files/model_x_owners_manual_north_america_en.pdf
- [90] Tesla, “2016 Tesla Model X P90D Ludicrous First Test Review,” retrieved on 2019-03-19. [Online]. Available: <https://www.motortrend.com/cars/tesla/model-x/2016/2016-tesla-model-x-p90d-ludicrous-first-test-review/>
- [91] G. Kable, “Bmw i4 four-door ev coupé to rival tesla model 3,” *Autocar*, 2018, retrieved on 2019-05-02.
- [92] L. Allan, “Audi e-tron gt tesla-baiting ev prototype rated,” *Autocar*, 2018, retrieved on 2019-05-02.
- [93] C. T. (CN), “Two-speed transmission powertrain for use in purely electric vehicle,” May 3 2018, wO2018076847 (A1). [Online]. Available: https://worldwide.espacenet.com/publicationDetails/biblio?CC=WO&NR=2018076847A1&KC=A1&FT=D&ND=3&date=20180503&DB=&locale=en_EP#
- [94] M. Zhou, R. Wang, and X. Xu, “Installation structure of electric vehicle powertrain,” July 16 2014, cN203713508 (U). [Online]. Available: https://worldwide.espacenet.com/publicationDetails/biblio?CC=CN&NR=203713508U&KC=U&FT=D&ND=4&date=20140716&DB=&locale=en_EP#
- [95] B. Peglowski, K. Martin, C. Campton, C. Blair, and B. Lee, “Rotating multimode clutch module for all wheel drive system,” February 28 2019, uS2019063513 (A1). [Online]. Available: https://worldwide.espacenet.com/publicationDetails/biblio?DB=EPODOC&II=0&ND=3&adjacent=true&locale=en_EP&FT=D&date=20190228&CC=US&NR=2019063513A1&KC=A1#
- [96] P. Valente, “All-wheel drive driveline with front limited slip differential,” November 22 2018, uS2018335121 (A1). [Online]. Available: https://worldwide.espacenet.com/publicationDetails/biblio?DB=EPODOC&II=1&ND=3&adjacent=true&locale=en_EP&FT=D&date=20181122&CC=US&NR=2018335121A1&KC=A1#
- [97] J. Kim, S. Youn, and Y. Kim, “Electric vehicle powertrain and parking control method thereof,” July 07 2019, uS2019072180 (A1). [Online]. Available: https://worldwide.espacenet.com/publicationDetails/biblio?CC=US&NR=2019072180A1&KC=A1&FT=D&ND=3&date=20190307&DB=&locale=en_EP#
- [98] B. Hoff, “In-line drivetrain and four wheel drive work machine using same,” April 26 2007, uS2007093343 (A1). [Online]. Available: https://worldwide.espacenet.com/publicationDetails/biblio?II=0&ND=3&adjacent=true&locale=en_EP&FT=D&date=20070426&CC=US&NR=2007093343A1&KC=A1#

-
- [99] Polestar, “Polestar 2 reveal | 100% electric | full presentation 40 min |,” retrieved on 2019-03-26. [Online]. Available: <https://www.youtube.com/watch?v=kVg5ycWTAhQ>
- [100] TransportPolicy.net, “International light-duty worldwide harmonized light vehicles test procedure (wltp),” retrieved on 2019-04-30. [Online]. Available: <https://www.transportpolicy.net/standard/international-light-duty-worldwide-harmonized-light-vehicles-test-procedure-wltp/>
- [101] S. T. Lundmark, “Course compendium part ii for the course lup 625 electric drives,” 2012.
- [102] T. Thiringer, “Electric machines,” March-May 2019, professional communication. Chalmers University of Technology, Volvo Cars.
- [103] C. Nordling and J. Österman, *Physics Handbook for Science and Engineering*, 7th ed. Studentlitteratur, 2004.
- [104] B. Noren, “Calculations and simulations,” May 2019, professional communication. Volvo Cars.
- [105] F. M. White, *Fluid Mechanics*, 7th ed. McGraw-Hill Education, 2011.
- [106] E. ToolBox, “Rolling reststance,” 2008, retrieved on 2019-05-21. [Online]. Available: https://www.engineeringtoolbox.com/rolling-friction-resistance-d_1303.html
- [107] F. Eriksson, E. Larsson, and G. Wahde, *Grundläggande matematisk analys för teknik och naturvetenskap*, 15th ed., 1984.
- [108] E. A. Grunditz and T. Thiringer, “Characterizing bev powertrain energy consumption, efficiency, and range during official and drive cycles from gothenburg, sweden,” *IEEE Transactions on Vehicular Technology*, 2016, retrieved on 2019-03-20.
- [109] Miljöfordon.se, “Elbil och laddhybrid,” retrieved on 2019-03-21. [Online]. Available: <https://www.miljofordon.se/bilar/elbil-och-laddhybrid/>
- [110] newsroom, “800-volt charging,” retrieved on 2019-05-27. [Online]. Available: <https://newsroom.porsche.com/en/technology/porsche-engineering-e-power-electromobility-800-volt-charging-12720.html>
- [111] M. P. Francesco Del Pero, Massimo Delogu, “Life cycle assessment in the automotive sector: a comparative case study of internal combustion engine (ice) and electric car,” *ScienceDirect*, 2018, retrieved on 2019-05-14.