

IMAGINING

ARCH

ITEC

TURE

DESIGN THROUGH SEQUENTIAL PERSPECTIVE DRAWINGS



CHALMERS
UNIVERSITY OF TECHNOLOGY

Imagining Architecture

*Design through sequential
perspective drawings*

© 2018 Björn Lindell
Chalmers University of Technology
Master Thesis in Architecture and Civil Engineering
Matter, Space, Structure Studio
Gothenburg, Sweden 2018

Examiner: Morten Lund
Supervisor: Peter Christensson

Abstract

Perspective drawings or perspective illustrations has long been part of the architect's two-dimensional tool box, alongside the plan and the section. It seems, however, that the perspective illustration has been consigned to, perhaps what its name implies: a mainly illustrative or representative role.

This thesis investigates the potential of a method solely relying on sequential perspective drawings when designing space.

The approach of the project was to investigate the theorized method by applying it to a specific program. This program was a place for ceremony and contemplation and the design consideration was limited to four aspects of exploration: form, space, light and color. Each aspect of exploration was investigated through sequential perspective drawings, realized as walks through the space. The sequences were drawn iteratively with an increasing degree of complexity, which resulted in a substantial collection of perspective sequences illustrating this process.

From producing this material, conclusions could be drawn about the benefits, limitations and potential applications of the proposed method. The method inherently holds a certain resistance that makes it time-intensive, which imposes limitations in regards to its applicability. However, this inherent resistance, when conquered, brings with it a deep understanding of one's own imagined spaces. This way of working can therefore hold high didactic value in relation to imagination and spatial understanding.

Foreword

Just a week before I entered the architecture programme at Chalmers University of Technology, my close friend and mentor, Tage, a man who taught me how to draw and paint, understand composition and color and who encouraged me to study architecture, passed away.

Last year we were given the chance to formulate our own project and I decided to take that opportunity to work on something personal: a memorial site for my friend. I wanted to work in a way that reminded me of the time the we had spent together and of what he taught me, so I chose to limit the project to the one thing that he and I spent most of our time together on: perspective illustrations.

Then, I did not see my way of working as anything resembling a method; I only saw it as, a small gesture and way of feeling close to my friend. It was only after the project was over, when I looked at the material I had produced and reflected on the process itself that a new idea was born. This idea is what I have explored further in my thesis.

Table of contents

Abstract.....	6
Foreword.....	8
Discourse.....	11
Preface.....	14
Approach.....	14
Starting point.....	16
Layers of complexity.....	16
Layers, Iterations.....	17
Iteration 1, <i>Rough outlines</i>	
<i>walk</i> (fragmented).....	19
Iteration 2, <i>Simple lines</i>	
<i>walk 1</i>	33
<i>walk 2</i>	39
<i>walk 3</i>	45
Iteration 3, <i>Simple line and shadow</i>	
<i>walk 1</i>	51
<i>walk 2</i>	57
<i>walk 3</i>	63
Iteration 4, <i>Refined line</i>	
<i>walk 1</i>	69
<i>walk 2</i>	75
<i>walk 3</i>	81
Iteration 5, <i>Refined line and shadow</i>	
<i>walk 1</i>	87
<i>walk 2</i>	93
<i>walk 3</i>	99
Iteration 6, <i>Color</i>	
<i>walk 1</i>	105
<i>walk 2</i>	143
<i>walk 3</i>	181
Drawings.....	219
Discussion.....	235
Conclusions.....	235
Recommendations / perspectives.....	236
Bibliography.....	238

Discourse

Gordon Cullen, *The Concise Townscape*. (1961)

The British architect Gordon Cullen states in his book *The Concise Townscape* (1961) that our environment is almost entirely apprehended through vision and he introduces the idea of what he calls “serial vision”. Cullen (1961) describes a sequence where one is walking through a town, along a strait road off which is a courtyard. One’s first view is of the street, turning in to the courtyard. A new view is revealed when turning, and this new view remains whilst crossing the courtyard.

“The human mind reacts to a contrast, to the difference between things, and when two pictures (the street and the courtyard) are in the mind at the same time, a vivid contrast is felt and the town becomes visible in a deeper sense.”

Here Cullen is speaking of experience and imagery in sequence, how the experience or imagery of one thing is stronger in contrast to another.

Sergei Eisenstein, *Montage And Architecture* (1989)

Sergei Eisenstein, the Soviet film director and film theorist, refers to space and imagery in sequence in his text *Montage and Architecture* (1989). Saying that architecture undoubtedly holds an historic role as an ancestor of film, of shot design and shot length, he even goes as far as to say that the Acropolis of Athens can be viewed as an example of one of the world’s most ancient films.

Both Eisenstein and Cullen use perspective illustration viewing the world, spaces, and architecture captured from the eyes of someone walking through a sequence of spaces, and they use the perspective to investigate, illustrate and communicate existing architecture.

Søren Kierkegaard, Concluding Unscientific Postscript (2009) PAGE 157

“For when all join together in making everything easier in every way, there remains only one possible danger, namely, that the ease becomes so great that it becomes altogether too easy; then there will be only one lack remaining, if not yet felt, when people come to miss the difficulty.

...

and out of a genuine interest in those who make everything easy, I conceived it as my task everywhere to create difficulties.”

This quote by Søren Kierkegaard (2009) which talks about the potential risks of ease, and hints at the possible rewards of difficulty, expresses something one, with benefit, can bear in mind when digesting this work.

Preface

This thesis is called *Imagining Architecture, Design Through Sequential Perspective Drawings*, and similarly to Cullen and Eisenstein it uses the view captured from the eyes of someone walking through a sequence of spaces. In contrast, it does not use the perspective illustration to investigate existing architecture or spaces, but rather in creating new ones.

This thesis investigates the potential of a method solely relying on sequential perspective drawings when designing space.

Approach

The approach of the project was to investigate the theorized method by applying it to a specific program. This program was a place for ceremony and contemplation and the design consideration was limited to four aspects of exploration: form, space, light and color. Each aspect of exploration was investigated through sequential perspective drawings, realized as walks through the space. The sequences were drawn iteratively with an increasing degree of complexity, which resulted in a substantial collection of perspective sequences illustrating this process.

Starting point

This project started with an idea, the program of ceremony and contemplation, and a limited site with an area of 150 x 60 meters. Beyond the more tangible starting point of the project, there were also partially formed pictorial ideas that held potential, informed the first steps of the design, and focused the scope of the investigation. This is important to know, as it explains that the method was used deliberately, investigating a specific situation and idea, rather than employed aimlessly.

Layers of complexity

In the case of the different areas of exploration, or layers of complexity, as they henceforth will be referred to as, each speaks to a different aspect of the design, and each gives you different knowledge when investigated. The delimitation to four layers of complexity in this project is just that, delimitation. There are other layers to explore than the ones chosen for this project: space, form, light and color. A couple of examples would be materiality and seasonal change, but there are naturally many more. What to choose or how to draw limitations entirely depends on what one wishes to explore. It does however seem to make sense, at least for most situations, to start with space and form, as they generally seem to hold the most fundamental information. This project does just that, starting with space and form, before expanding in to the two additional aforementioned layers.

ITERATIONS. LAYERS OF COMPLEXITY

1. Rough outlines. The first iteration looks at space and form through simple line drawings; drawings that are searching after space and form in a loose and intuitive manner, with little to no regard given to a sequence as a whole. Parts of sequence, the ideas that are clearest and most prominent, do however start to take form, a process that might be likened to that of laying a puzzle, working on several different areas at once, without yet seeing the full picture.

2. Simple lines. The second iteration stays with space, form and simple lines, but expresses itself in a more distinct and resolved way. The drawings are still searching, but are now clearer in their expression and content. The second iteration also establishes the sequence for the first time. The walk does not have to be fully resolved at this point; it can remain fluid and changeable throughout the entire process, it is however important that walk is established early on, as it effectively forms a framework from within which to continue iterating.

3. Simple line and shadow. The third iteration adds light and shadow to the existing line drawings. A lot of emphasis is placed on creating the right atmosphere and in establishing that the light - environment is uniform from drawing to drawing. This means assuring that the light is coming from the right, three-dimensional, direction in each frame and that the shadows are of a fitting length, as it greatly matter in creating a cohesive, interconnected and believable walk through the spaces.

(This iteration requires trial and error, a lot of time and careful planning; it truly forces one to be in the imagined space.)

4. Refined line. The fourth iteration is a re-drawing of the lines of the second iteration now in more rigged digital tool, (2D CAD) in order to increase the precision within each drawing. It is quite easy to hide unresolved areas or details in a hand drawing behind some squiggly lines or smudges; this however is not so easy in a strict digital tool like AutoCAD LT which was used in this case. This shift to a different and more precise tool forces one, when drawing the spaces again, to view them with new, and more exacting eyes.

4. Refined line and shadow. The fifth iteration is a re-drawing of the light and shadow in the third iteration, now, also done in 2D CAD. All consideration given to the light in the third iteration is revisited and overhauled ones more. The rigidity and precision given by the strict digital tool, described in the previous iteration, applies to the light and shadow in this iteration as well.

6. Color. The sixth iteration merges all the produced knowledge from the previous iterations before adding the final layer of complexity of this project: color. Working with the color in sequential drawings holds some similarities to working with the light. It is important that the color, from drawing to drawing, stays cohesive and interconnected; meaning that a particular surface in a space holds the same color from one drawing to the next.

In this project special consideration has been given to all drawings. There has been a conscious effort in making each drawing well composed, balanced and dynamic in regards to geometry, light and color. The color pallet is rich, varied and vibrant, which increases the complexity of its implementation, putting increased difficulty in to its balanced resolution, while, at the same time, hopefully establishing the desired atmosphere.

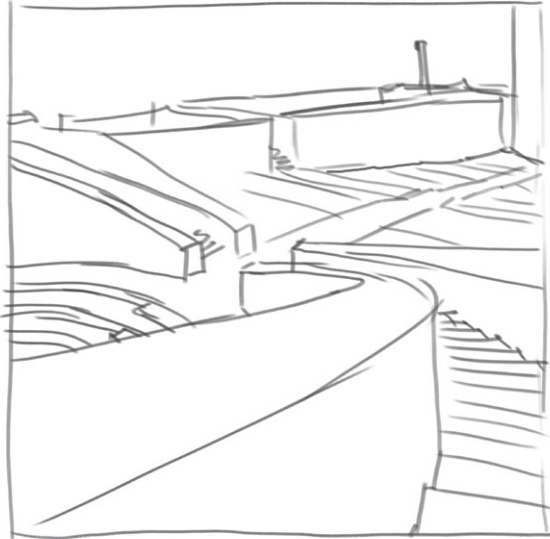

1

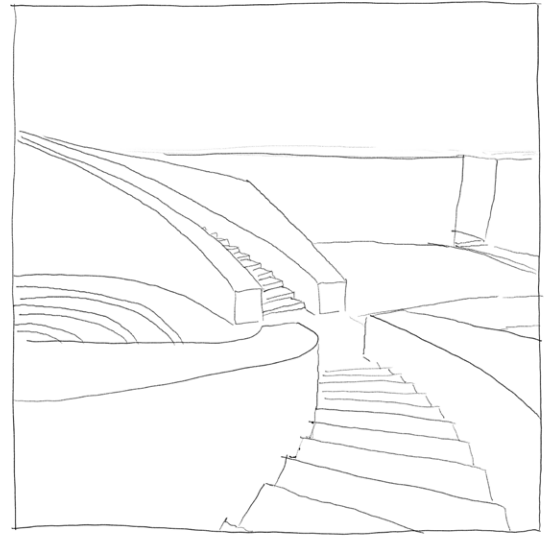

2

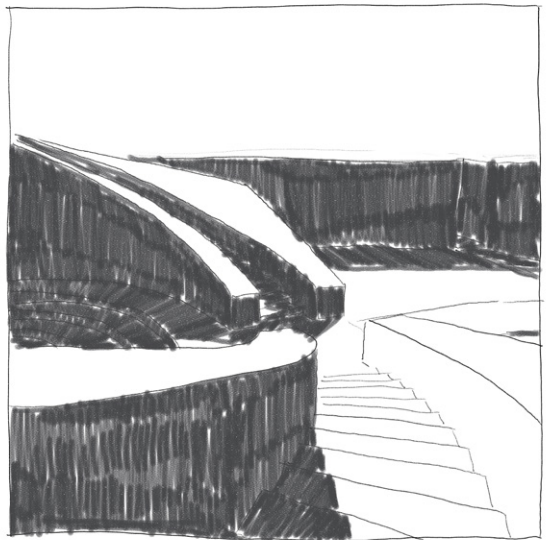

3

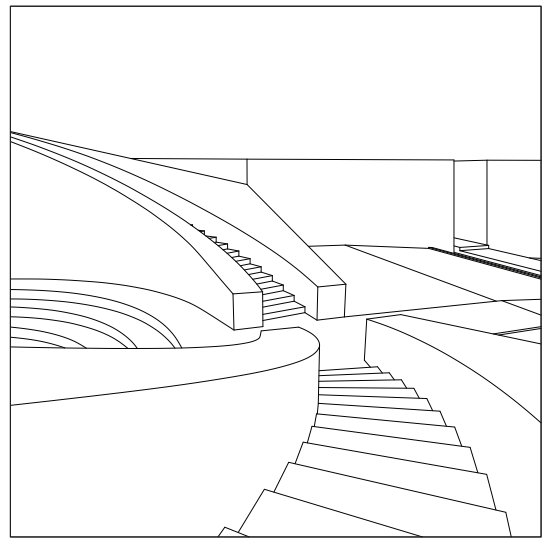

4

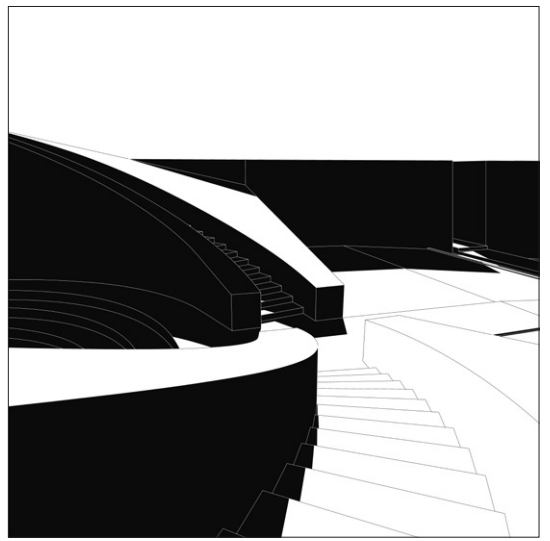

5

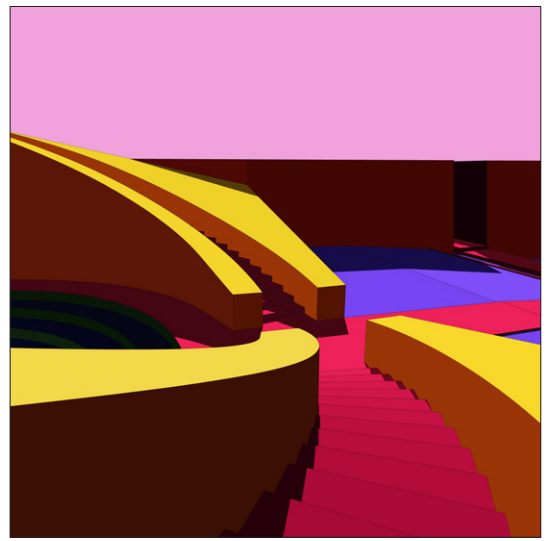

6

ITERATION 1. ROUGH OUTLINES

walk (fragmented)

layers of complexity (space and form)

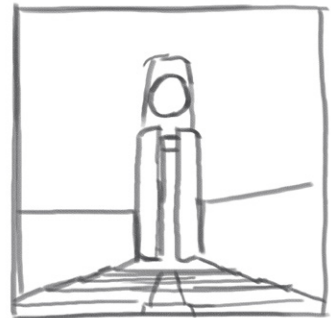
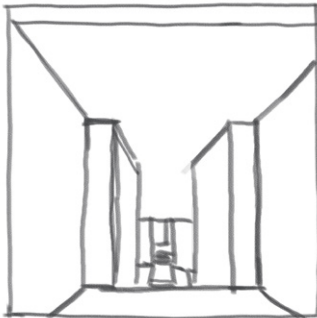
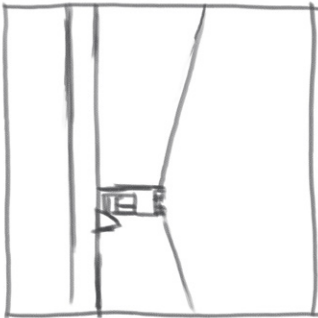
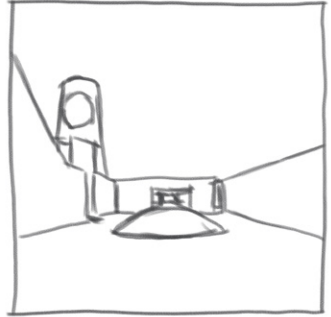
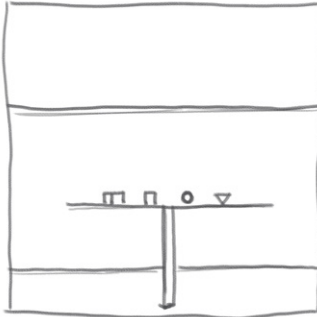
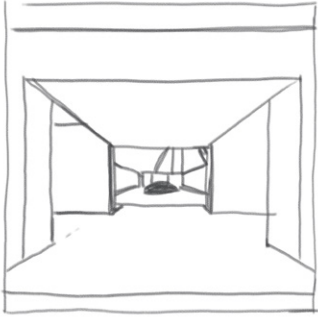
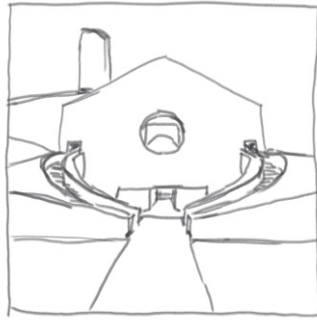
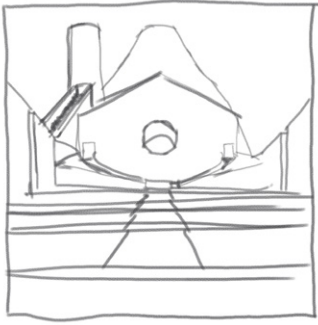

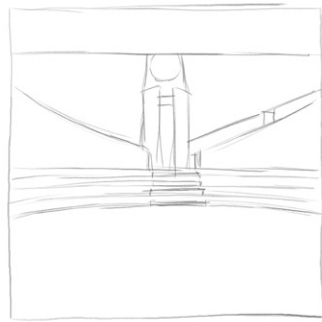
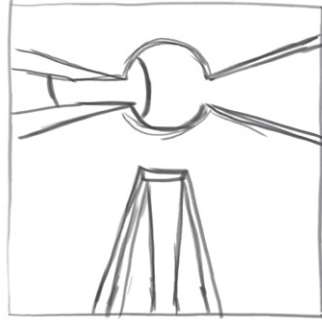
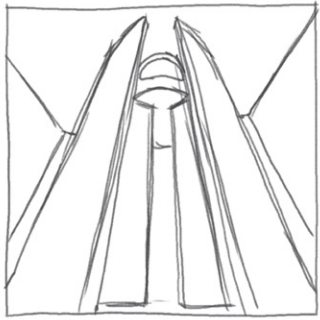
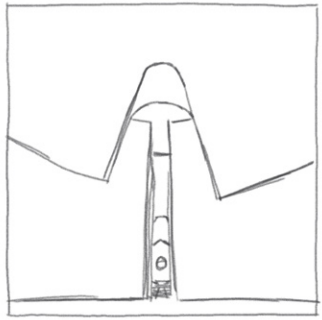
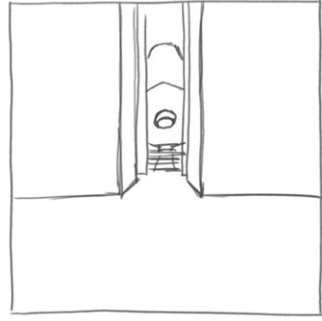
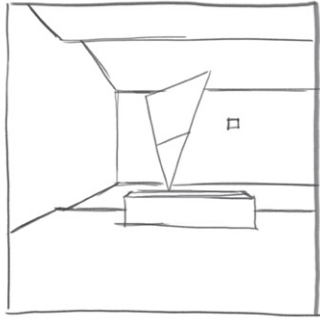

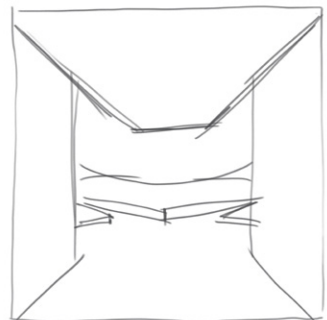
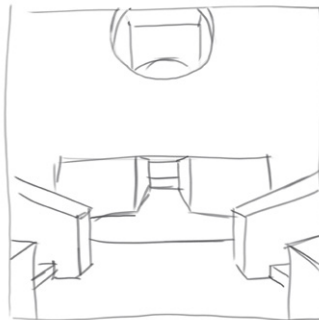
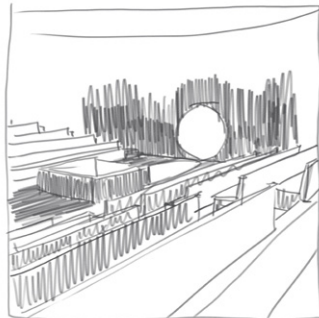
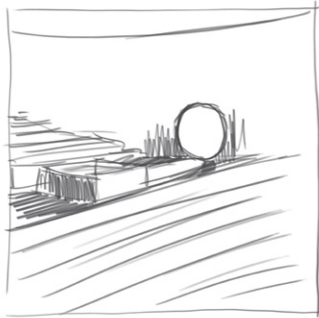
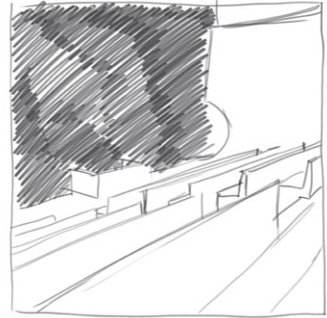
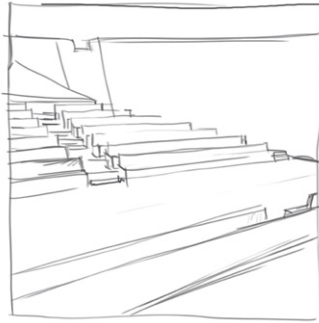
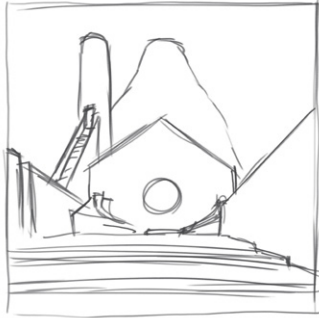

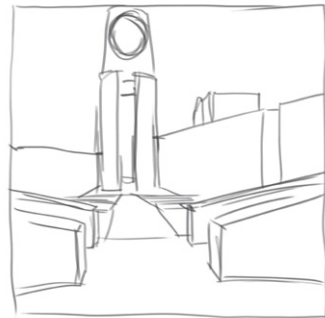
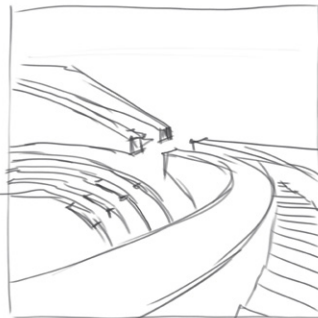
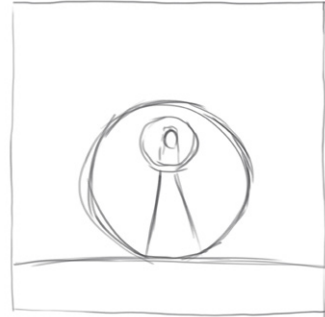
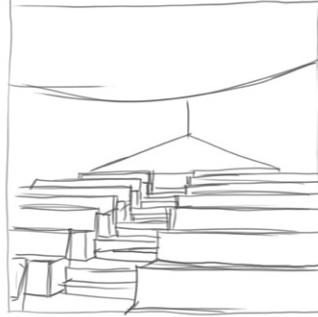
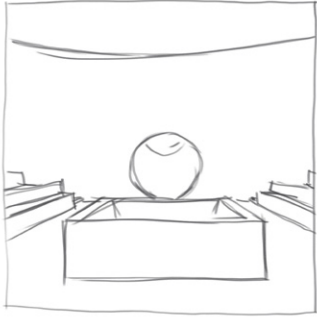
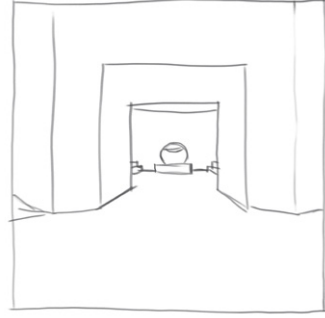
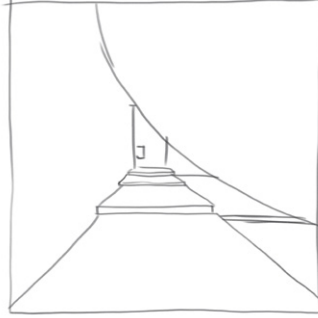

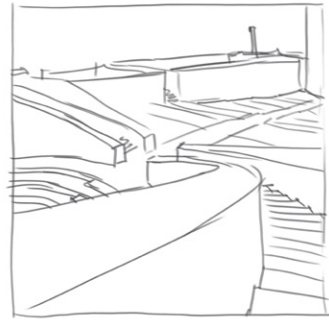
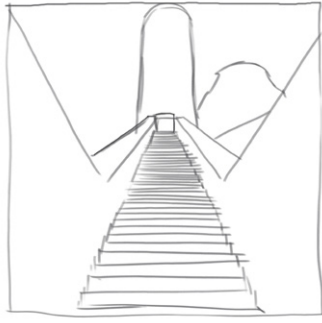
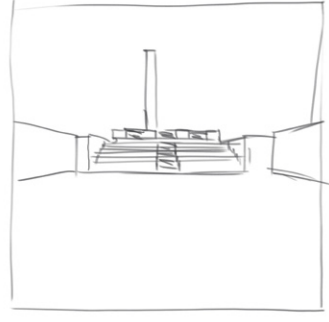
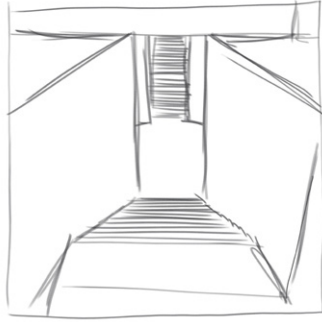
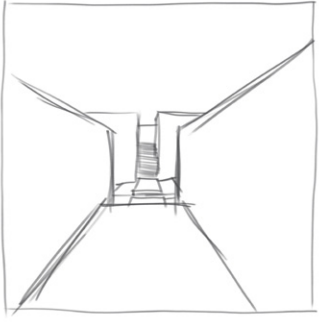
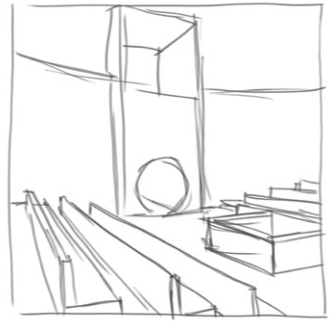
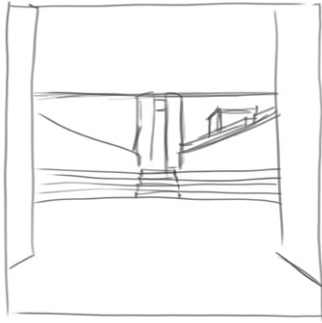

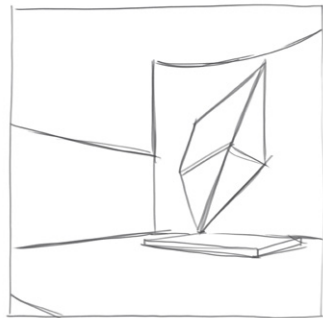
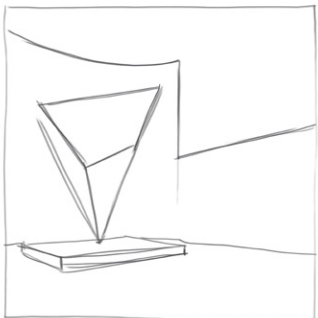
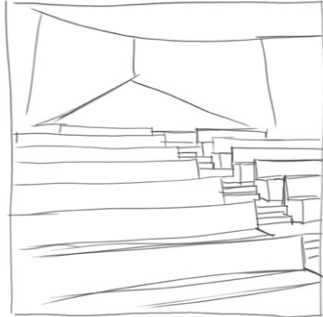
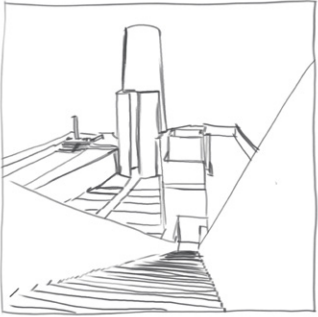
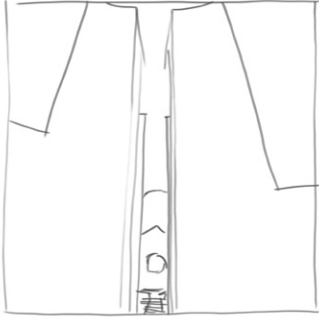
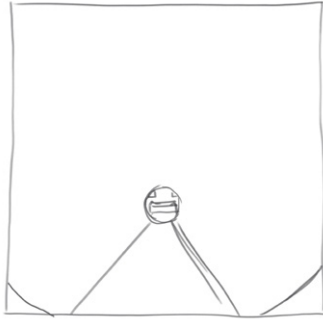
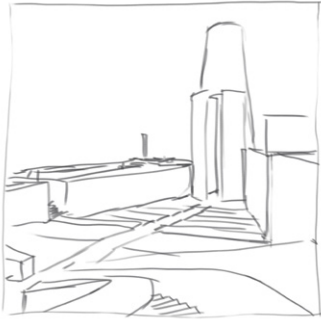

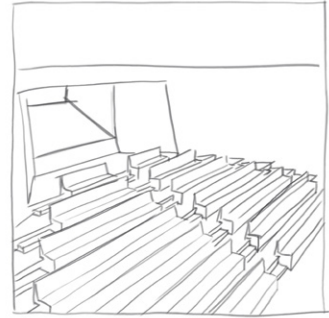
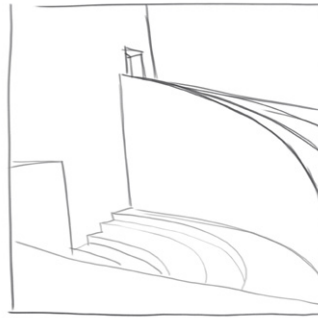
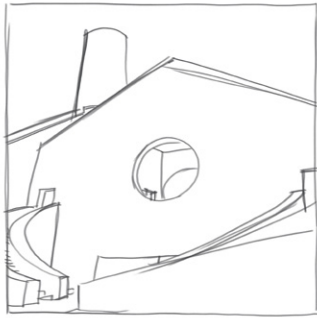
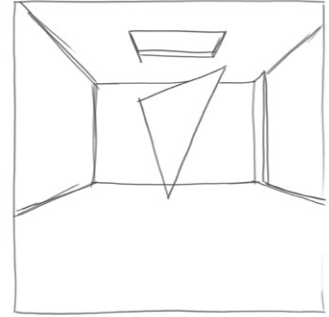
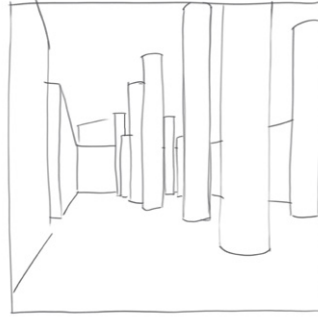
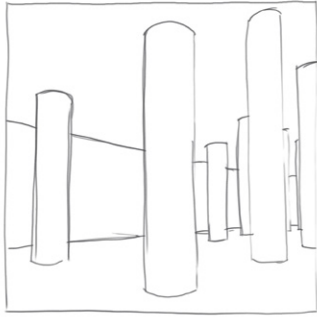
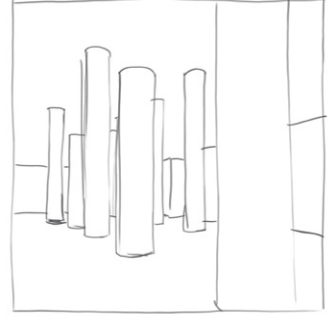
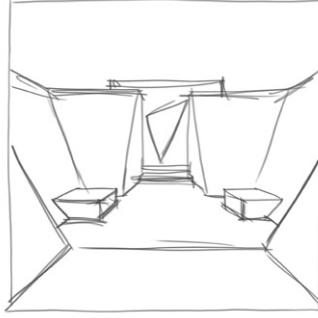
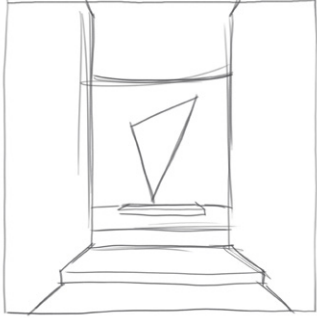

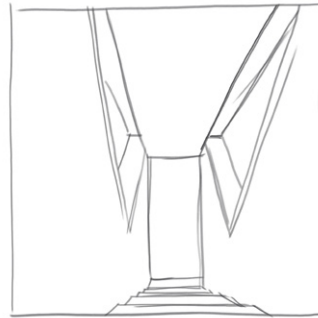
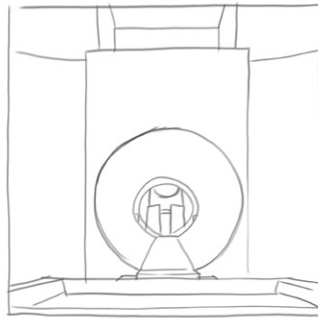
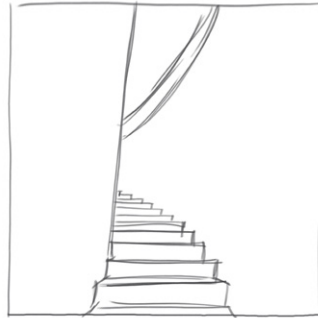
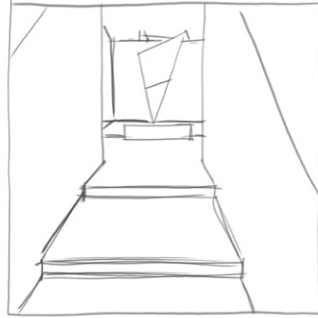
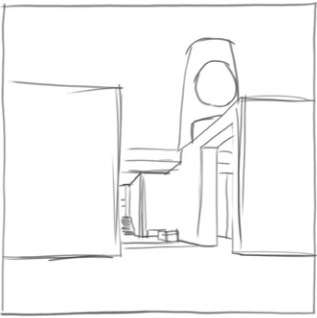
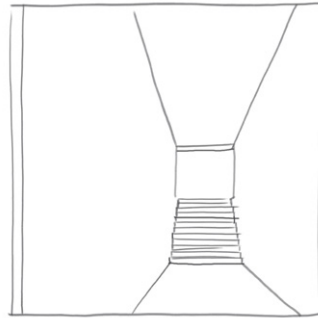
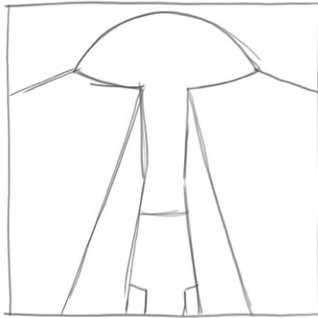
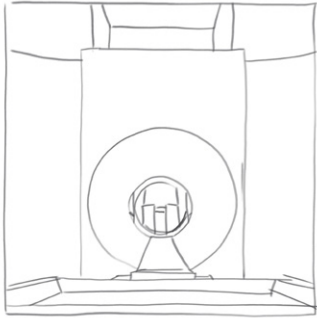

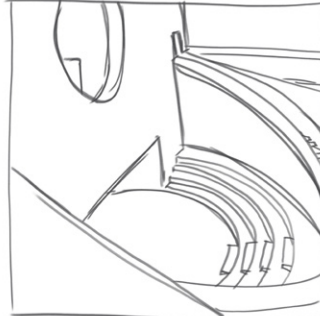
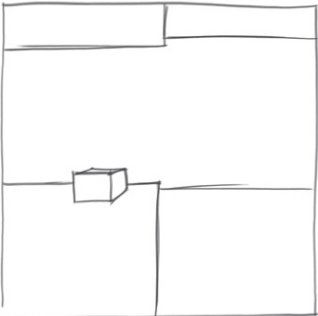
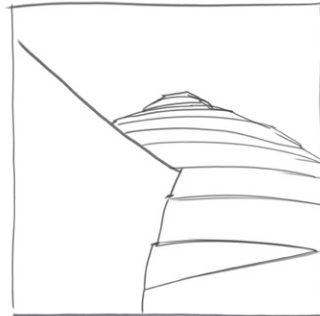
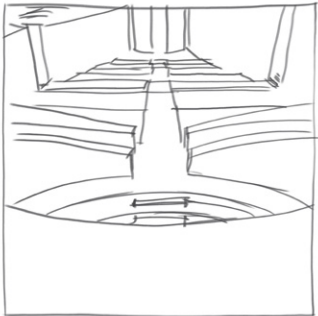
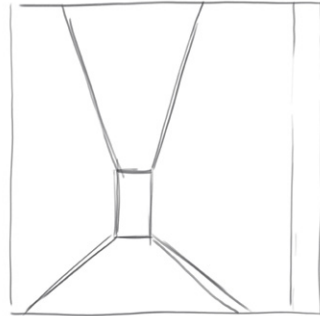
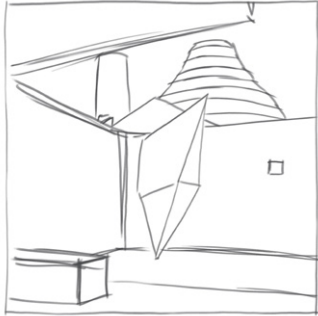
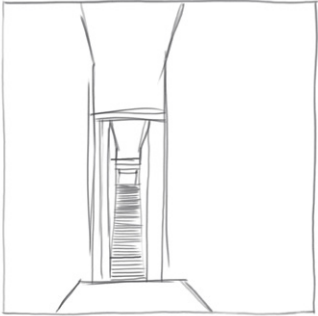

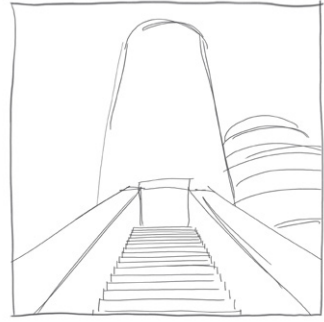
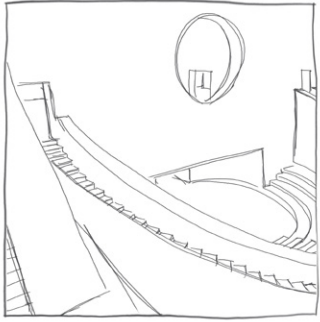
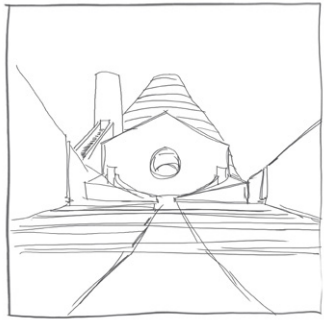
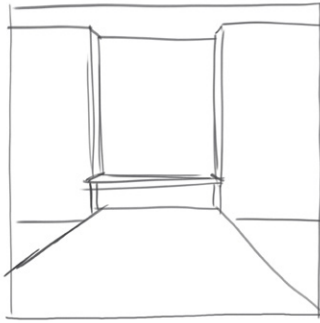
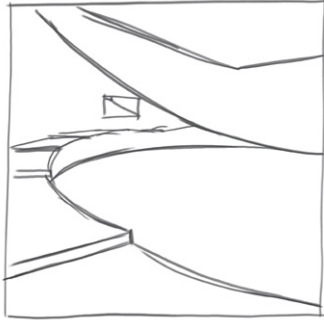
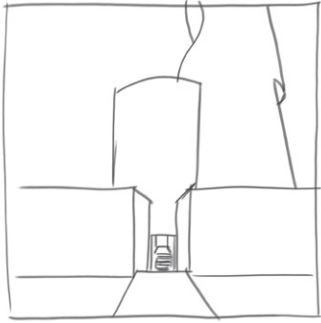

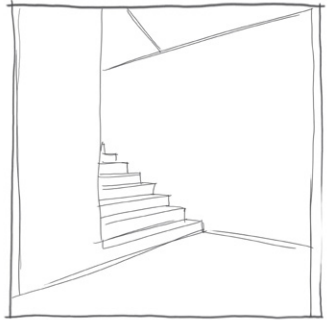
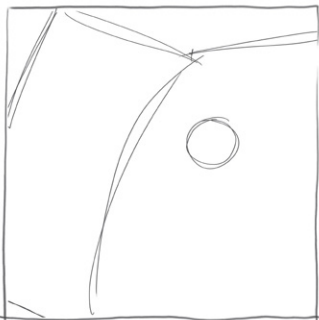
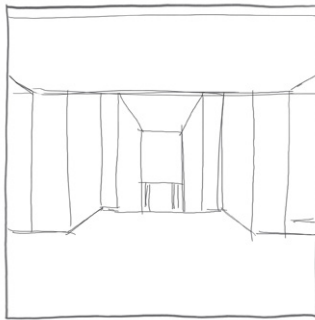
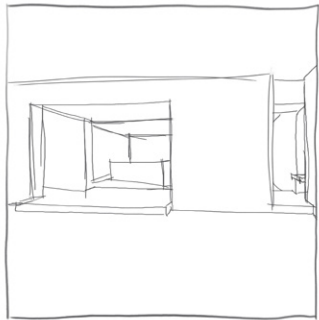
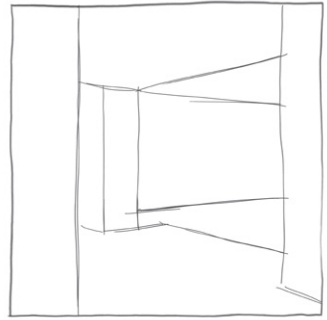
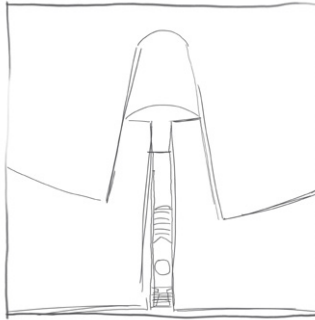
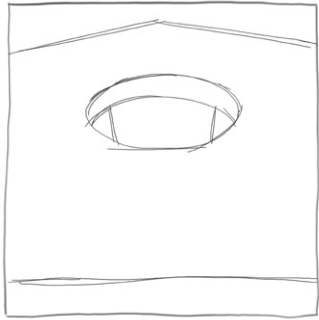

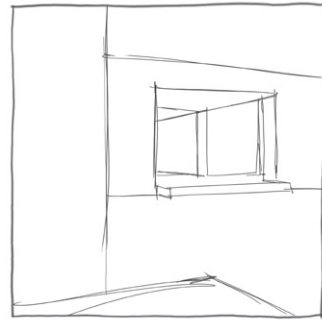
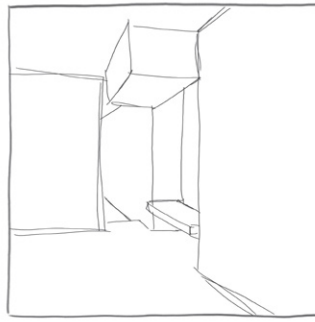
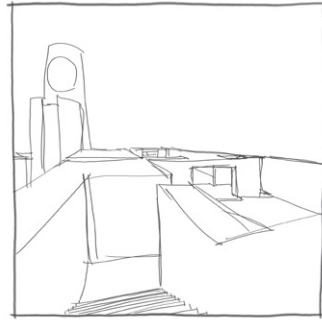
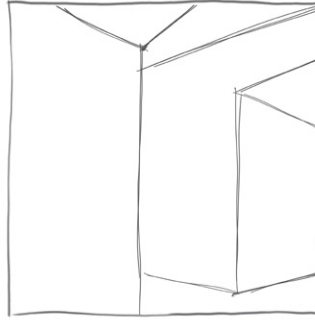
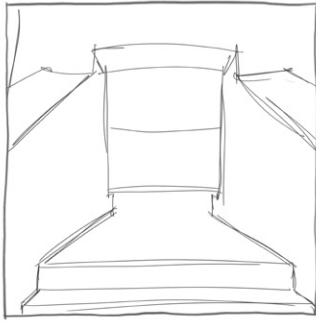
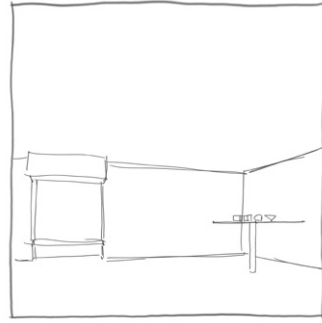
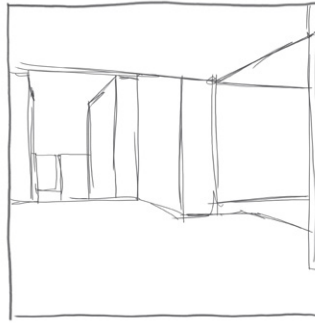
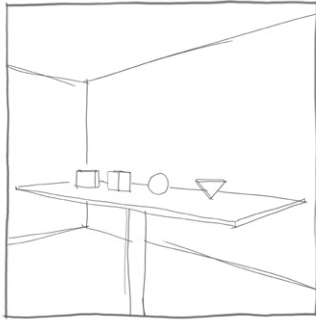

ITERATION 2. SIMPLE LINES

walk (1)

layers of complexity (space and form)

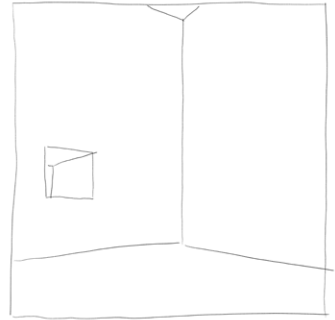
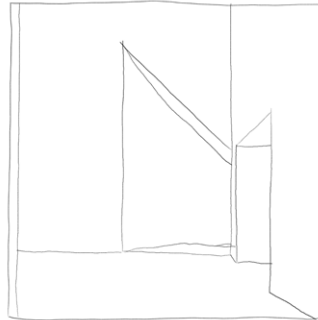
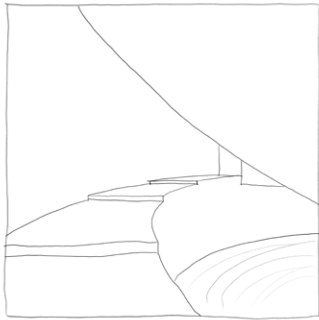
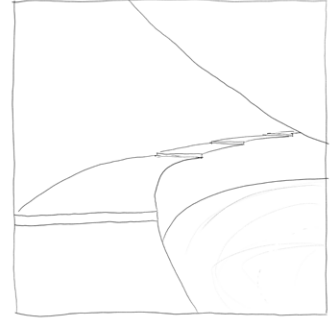
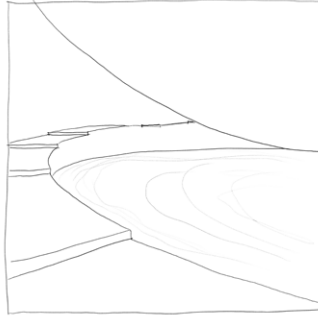
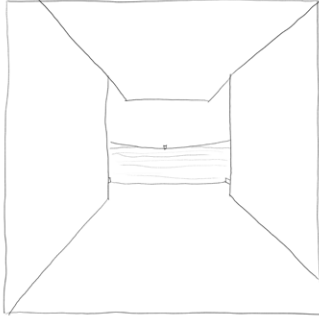
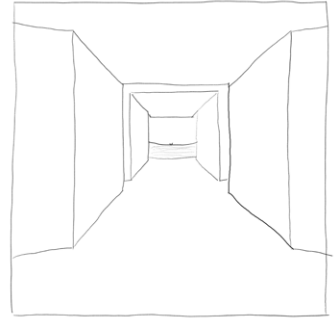
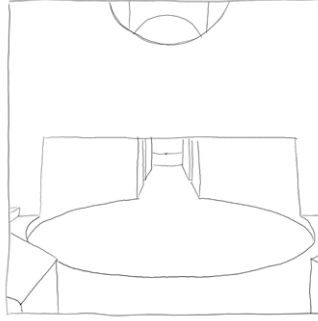
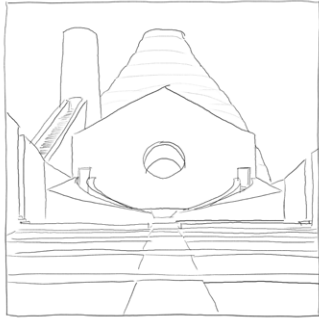

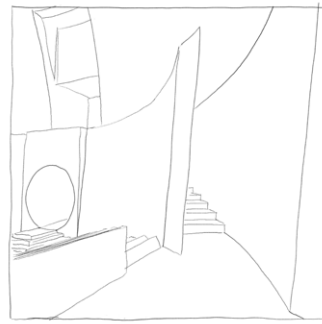
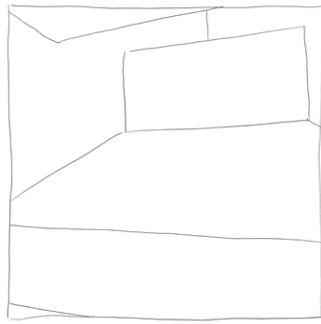
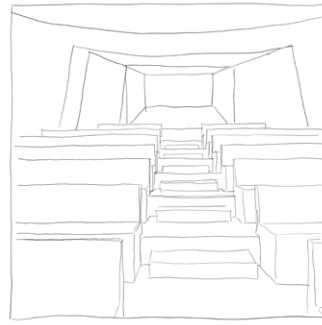
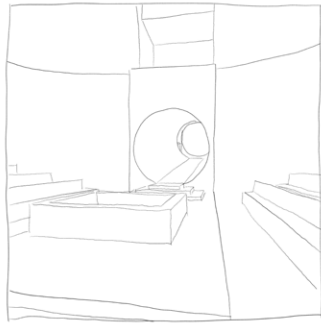
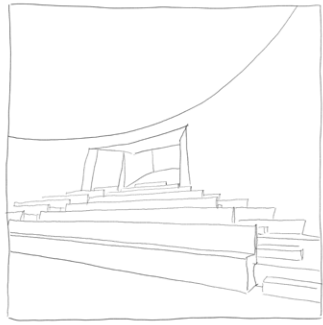
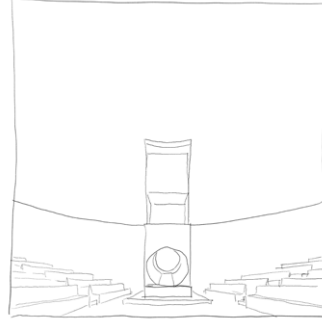
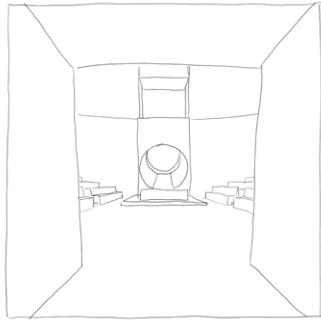
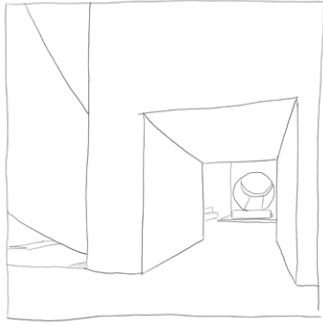

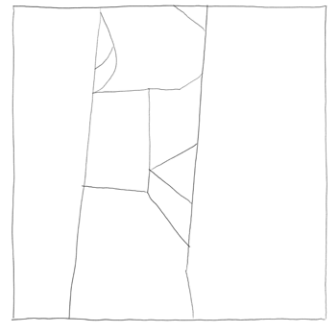
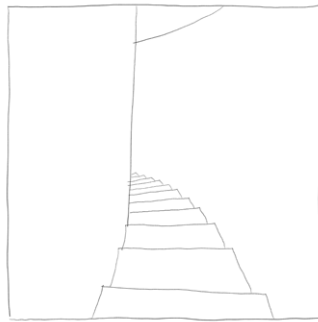
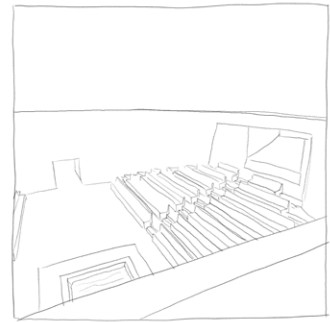
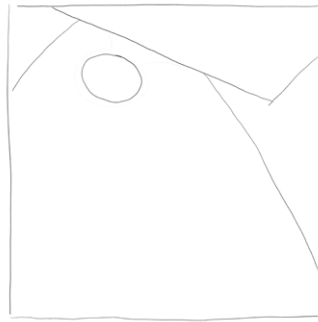
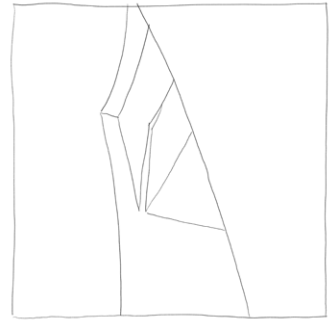
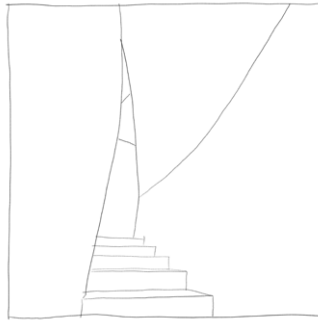

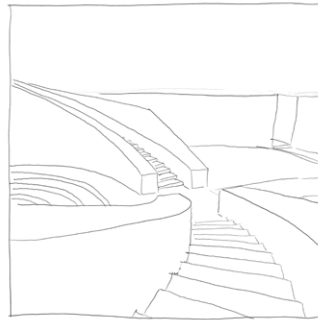
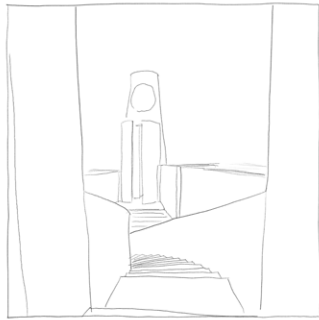
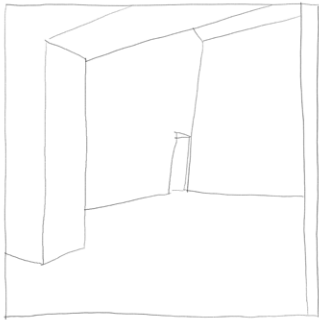
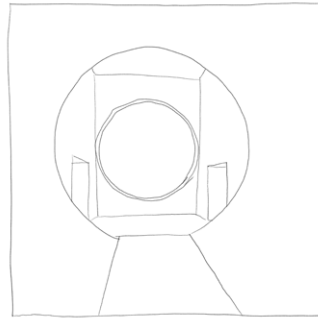
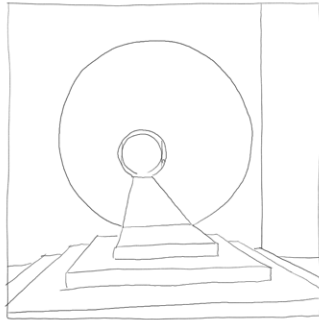
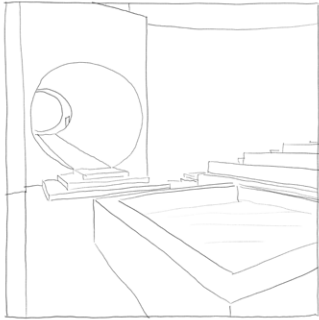
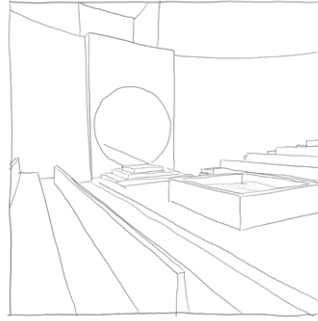
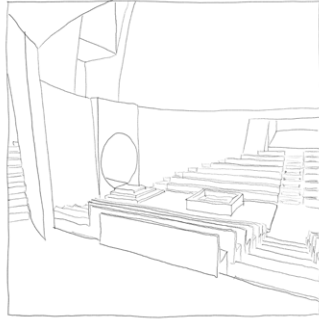
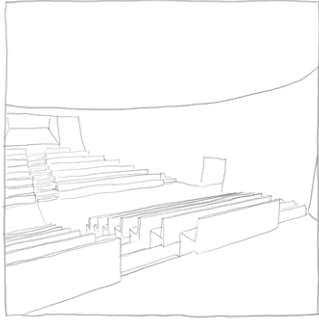

ITERATION 2. SIMPLE LINES

walk (2)

layers of complexity (space and form)

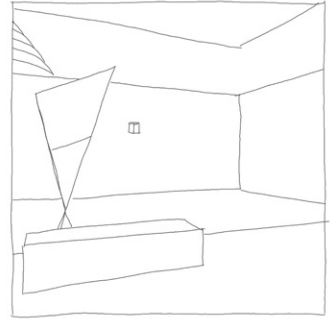
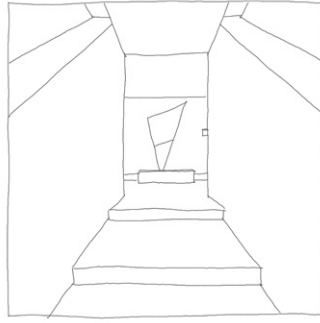
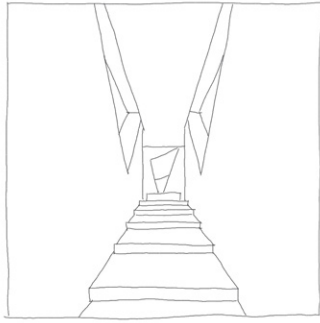
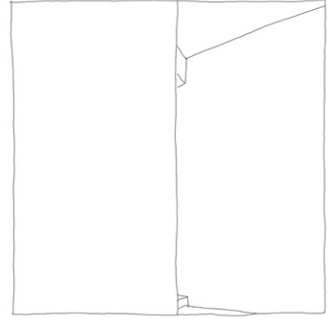
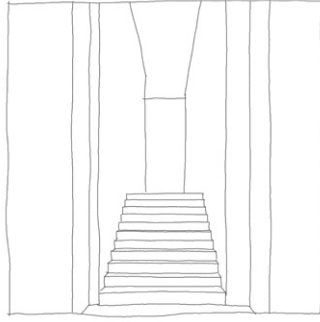
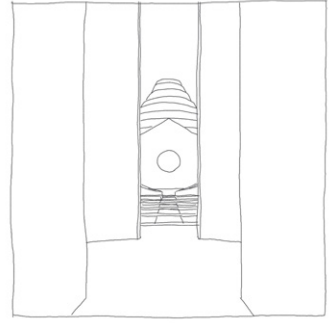
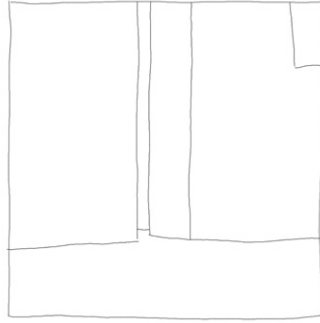

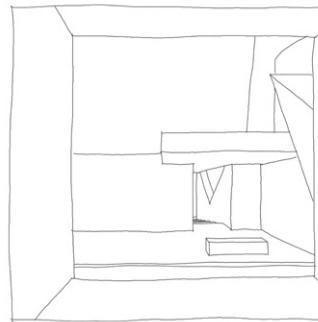
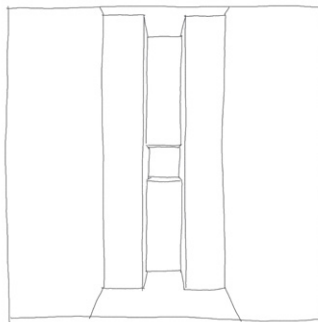
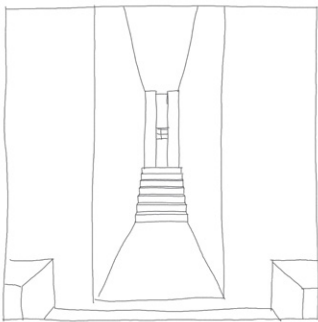
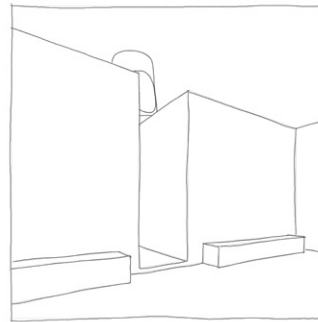
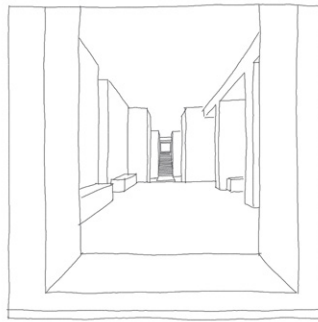
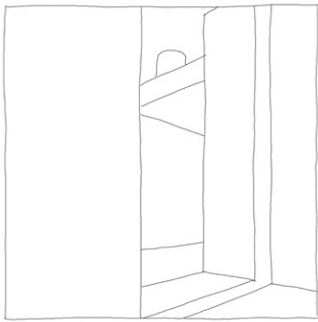
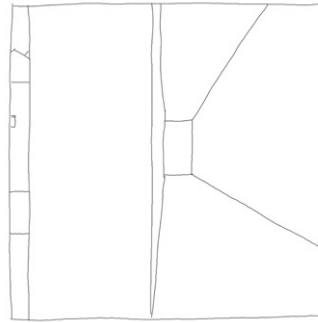
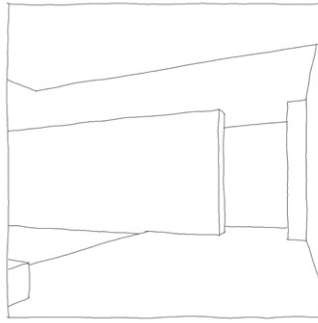
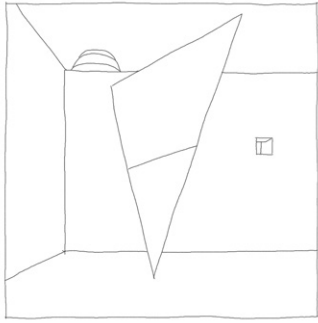

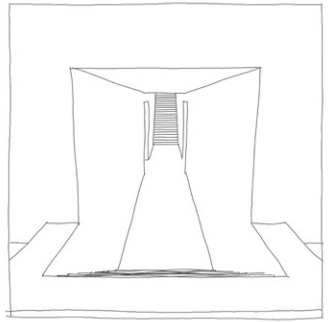
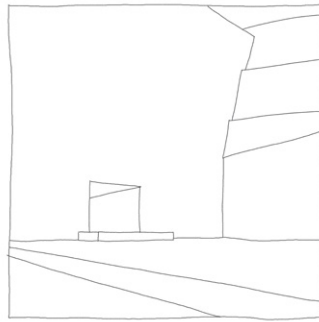
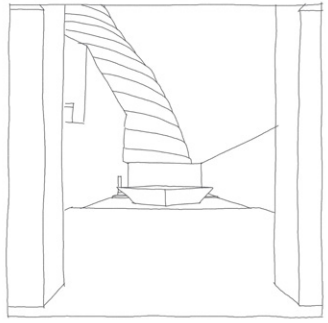
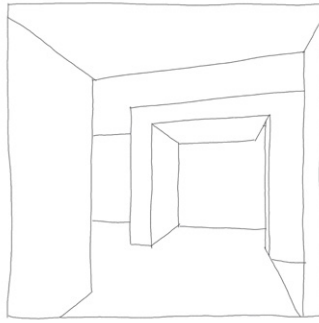
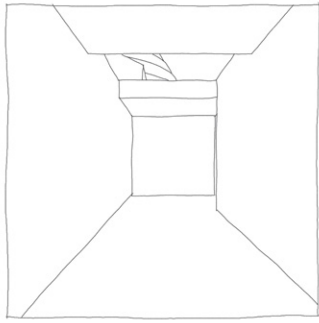
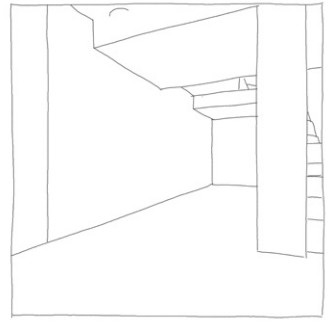
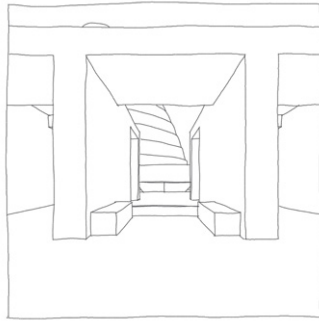
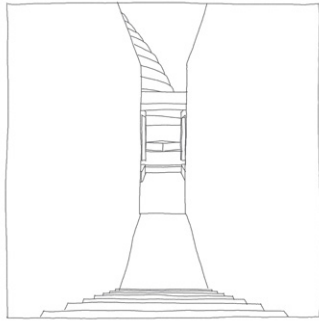

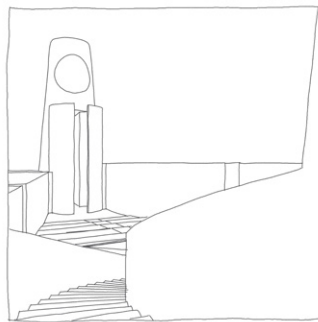
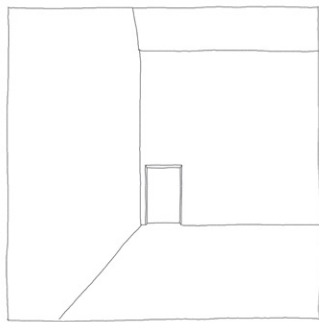
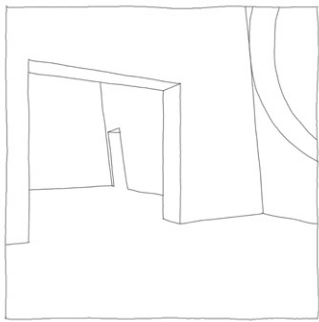
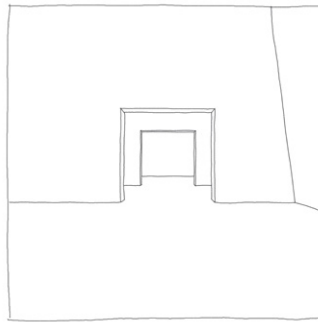
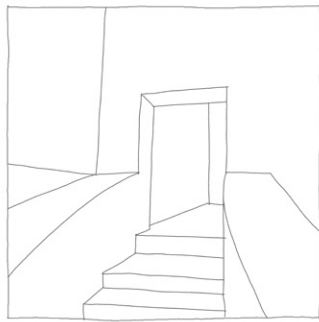
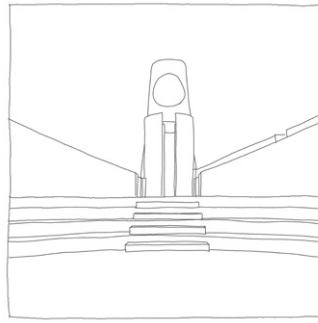
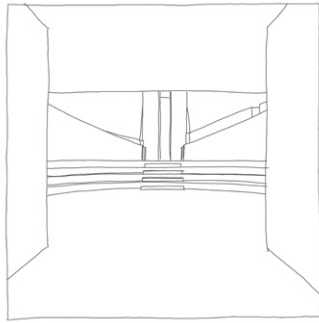
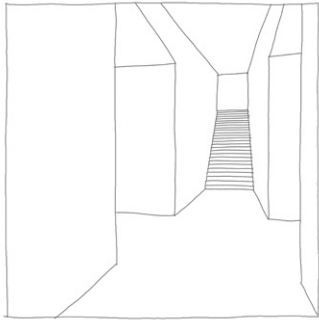

ITERATION 2. SIMPLE LINES

walk (3)

layers of complexity (space and form)

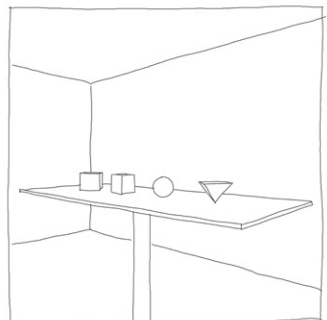
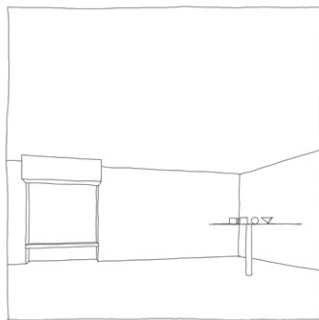
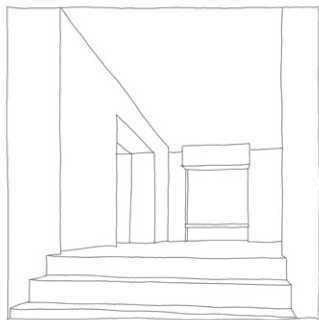
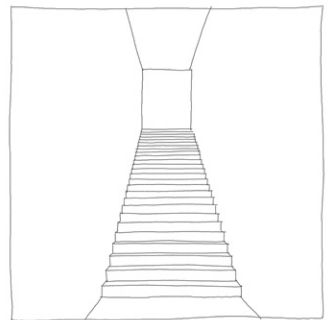
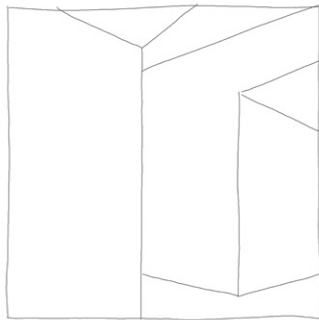
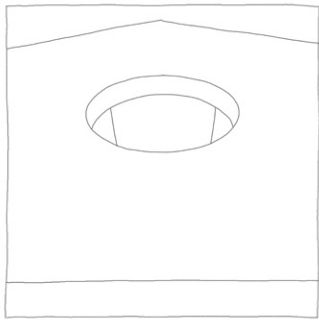
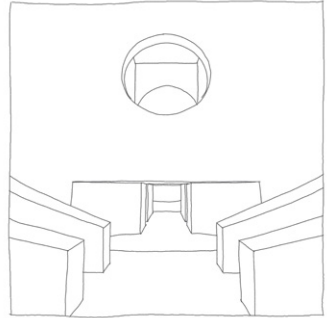
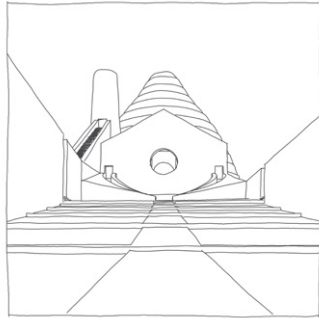
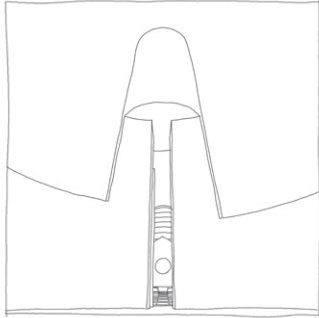

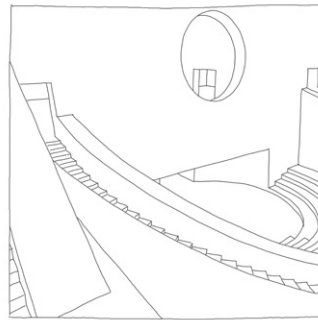
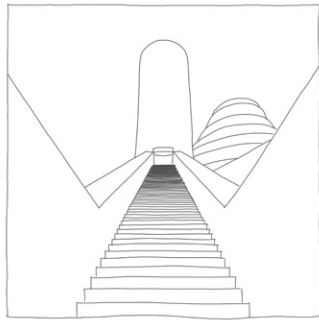
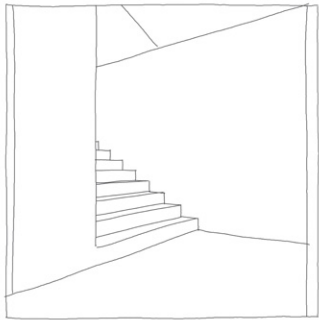
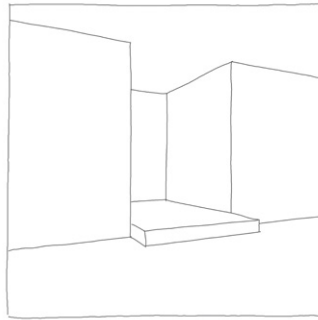
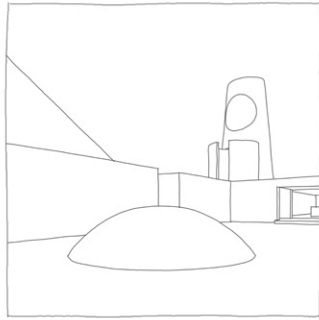
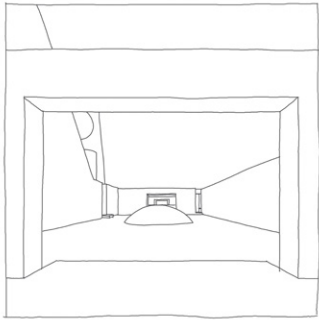
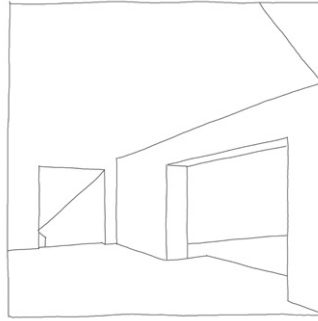
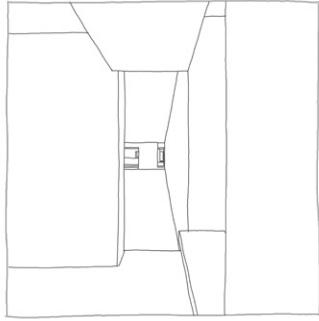
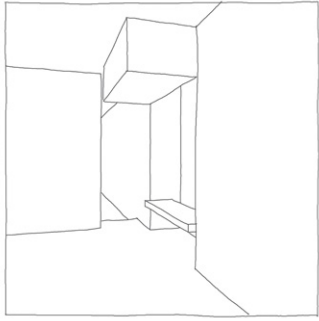

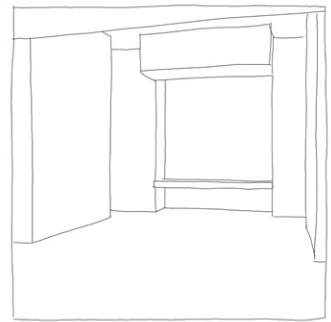
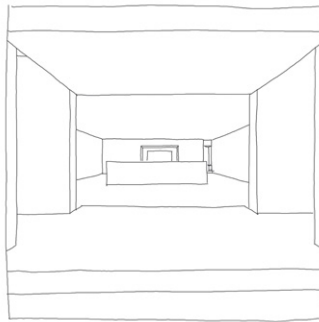
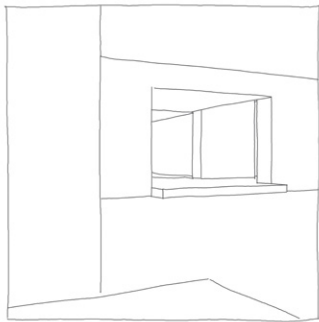
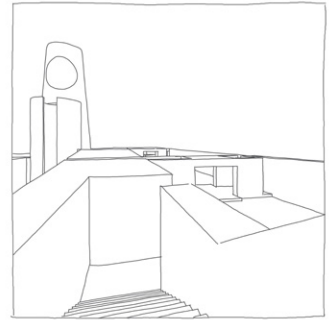
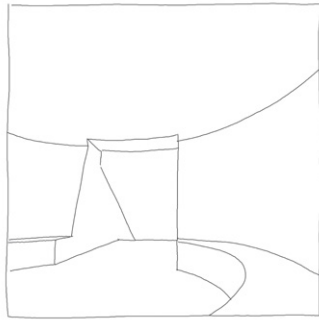
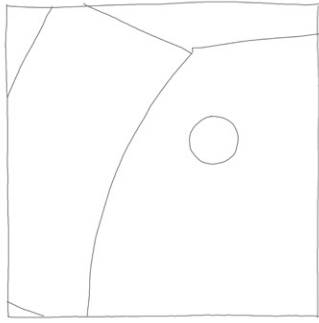
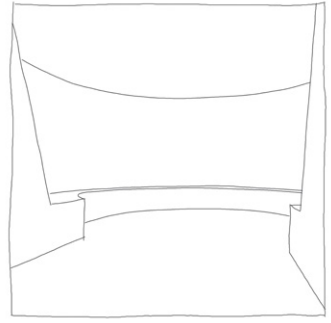
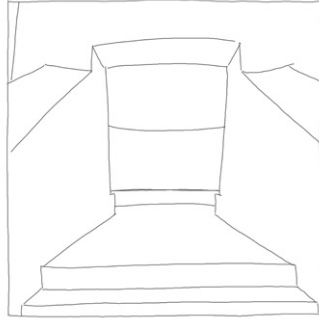

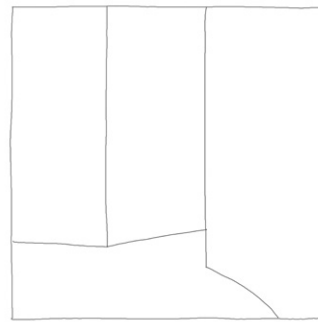
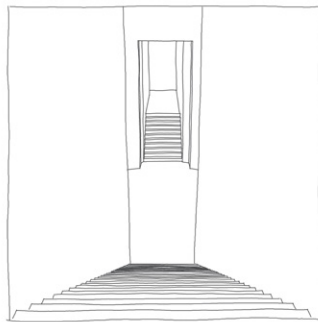
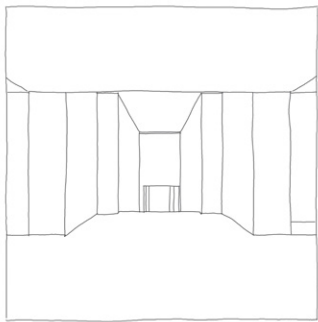
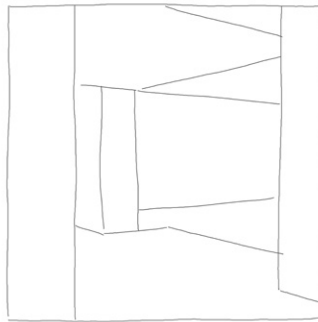
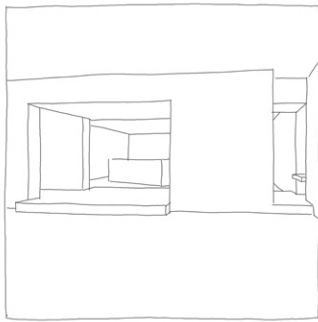
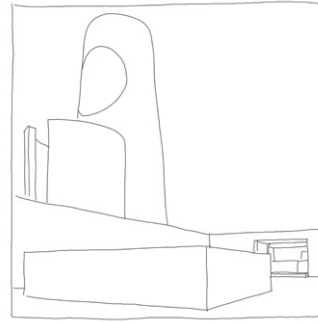
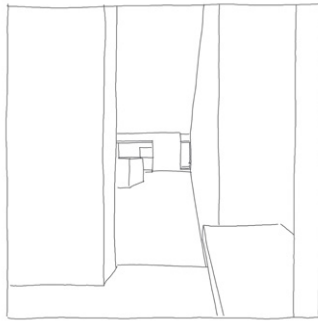
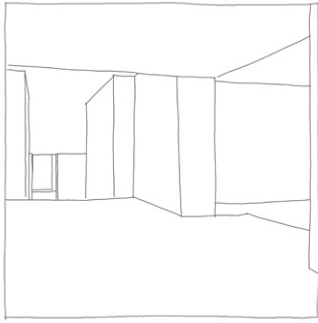

ITERATION 3. SIMPLE LINE AND SHADOW

walk (1)

layers of complexity (space, form and light)

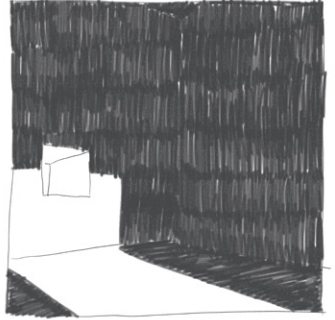
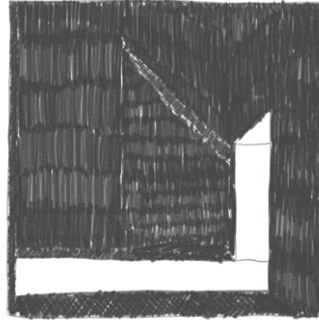
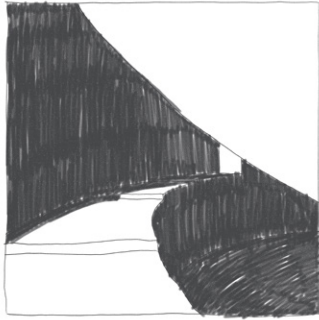
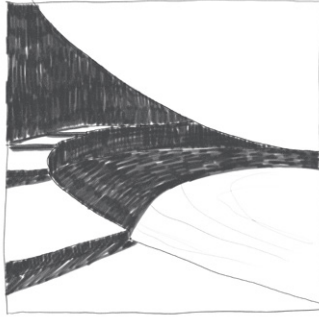
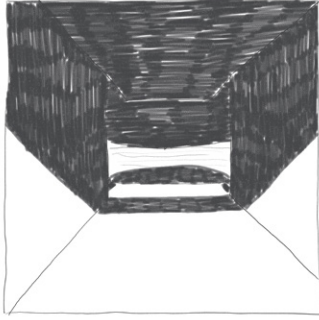
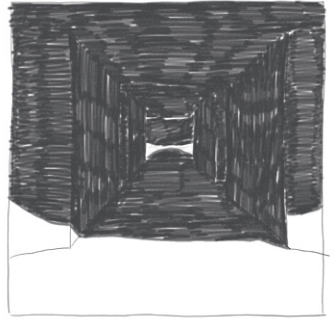
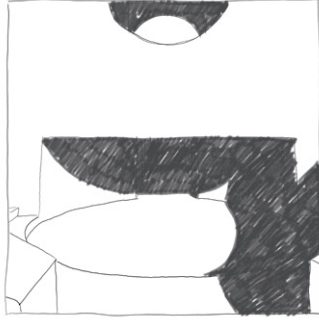
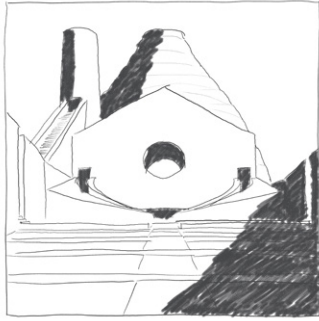

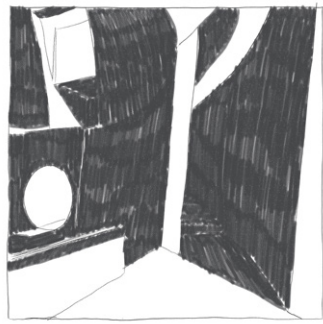
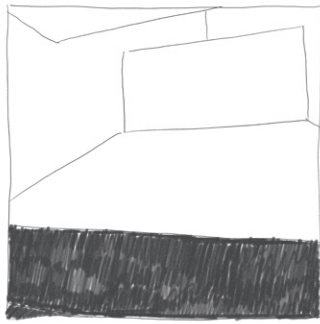
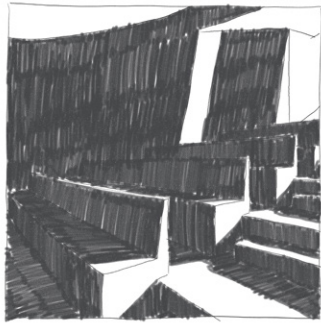
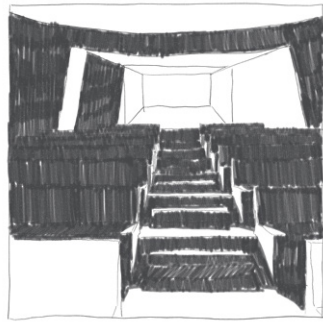
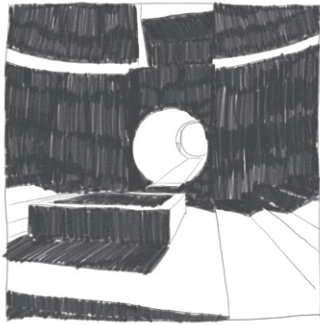
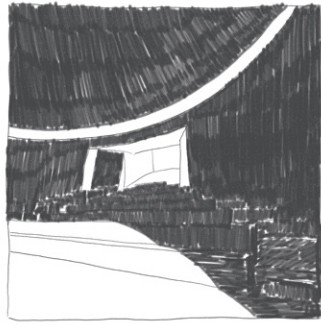
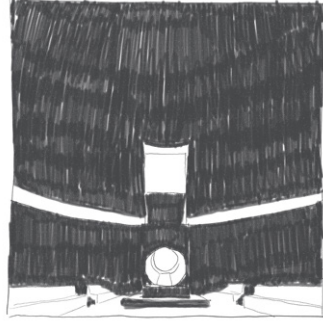
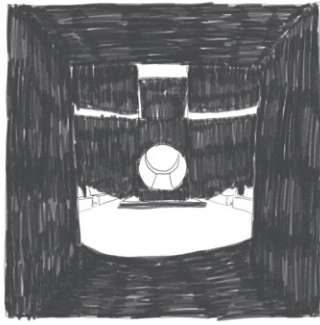
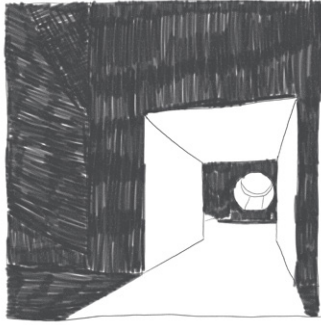

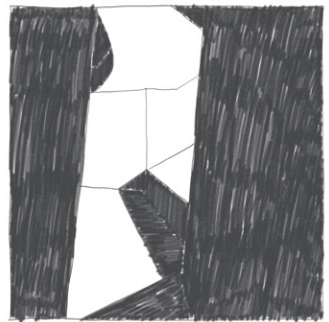
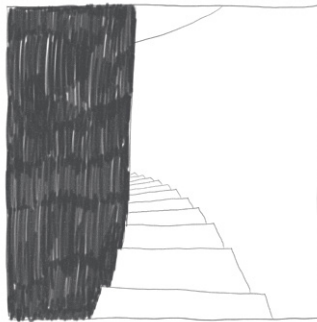
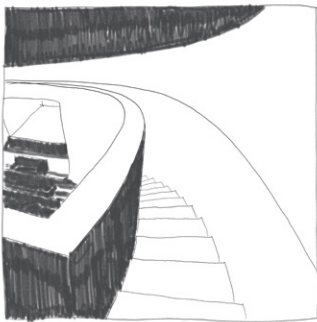
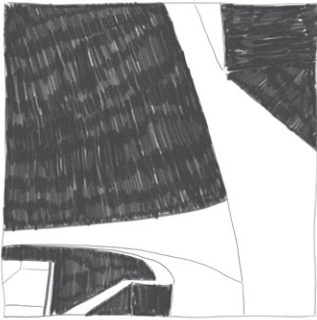
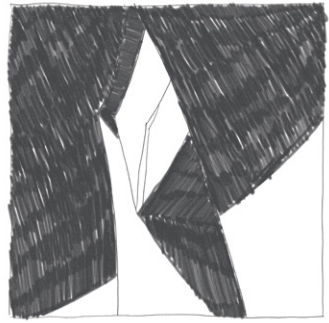
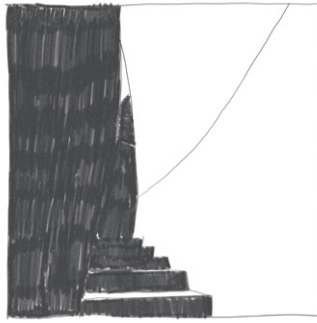
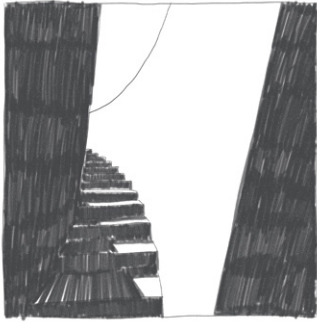

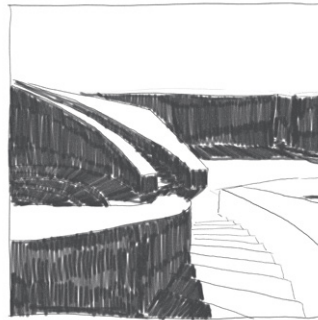
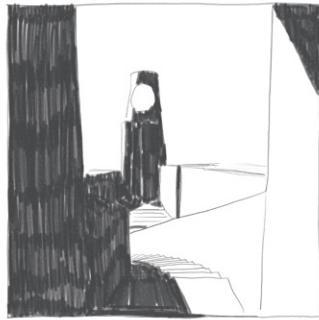
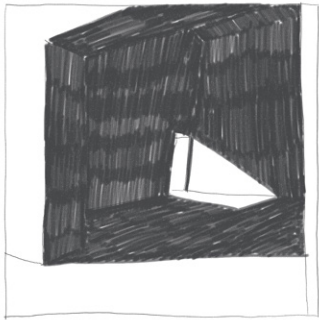
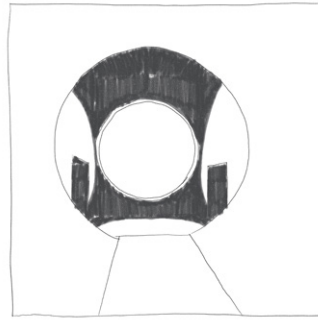
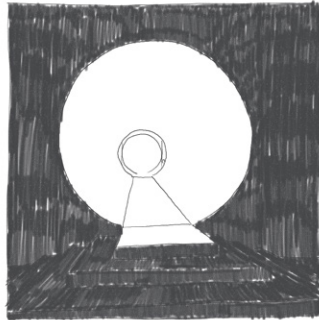
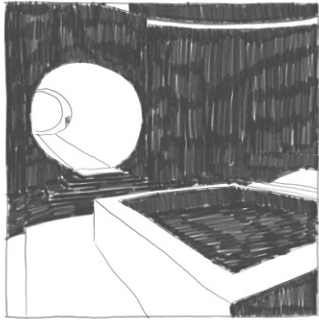
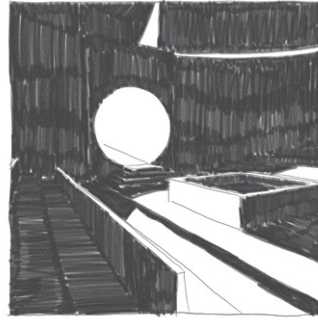
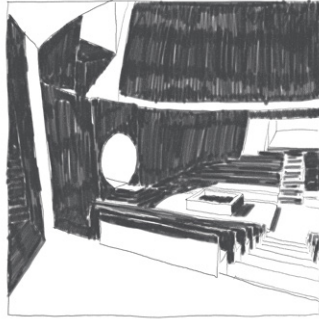
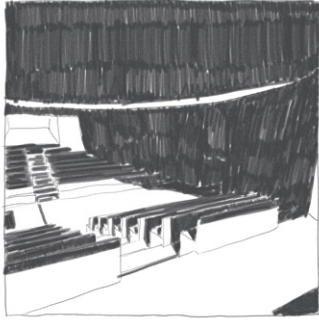

ITERATION 3. SIMPLE LINE AND SHADOW

walk (2)

layers of complexity (space, form and light)

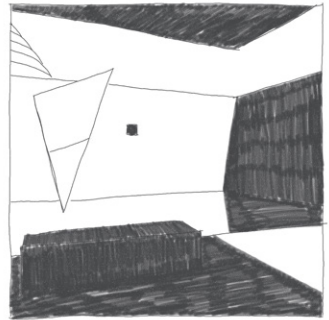
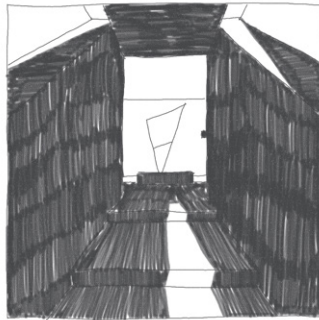
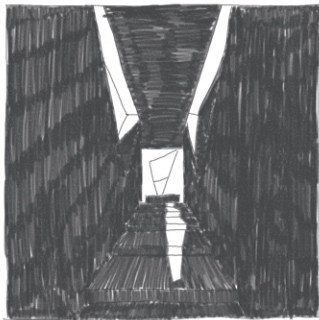
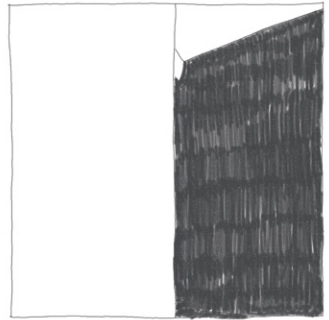
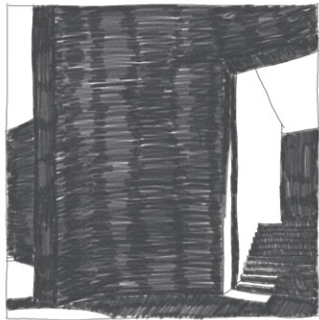
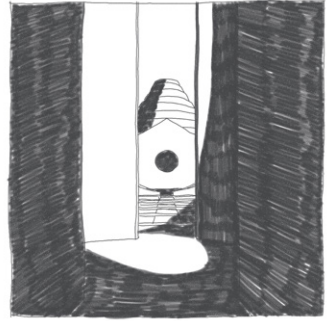
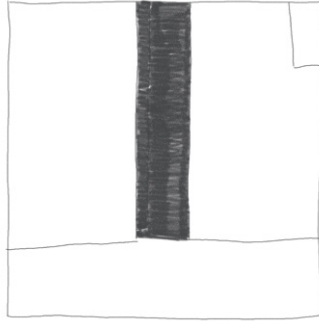

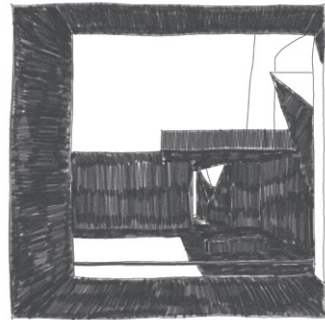
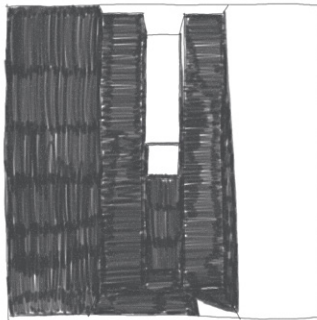
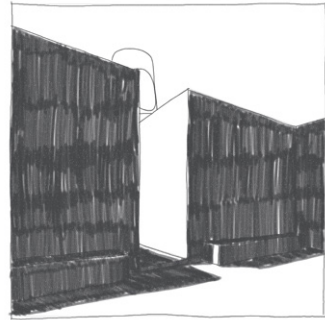
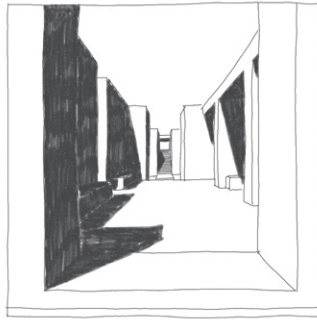
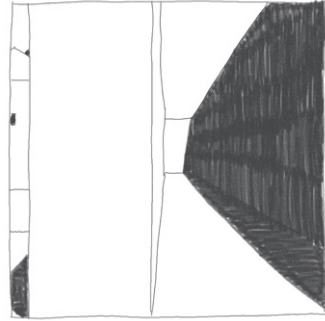
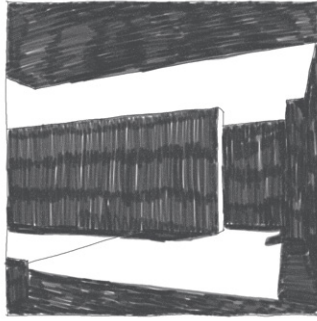
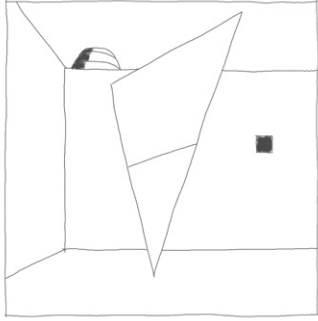

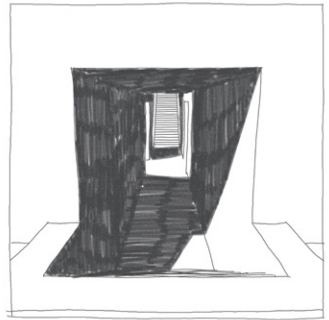
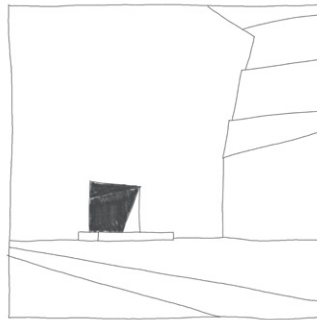
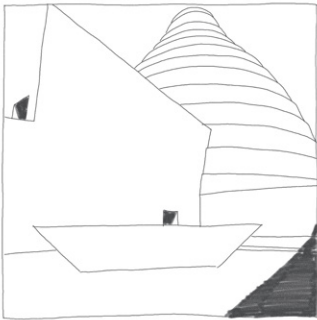
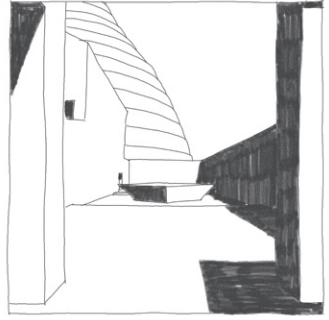
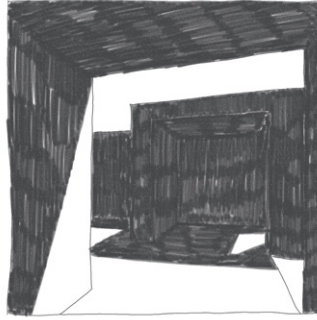
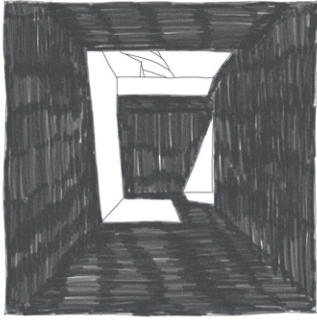
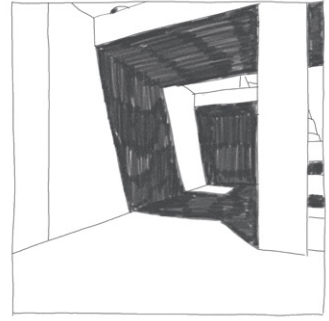
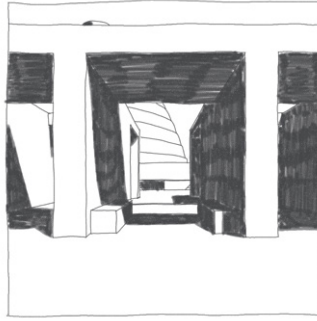
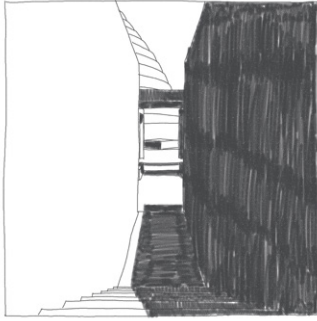

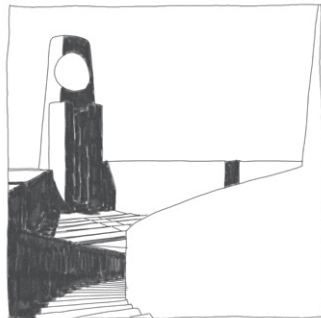
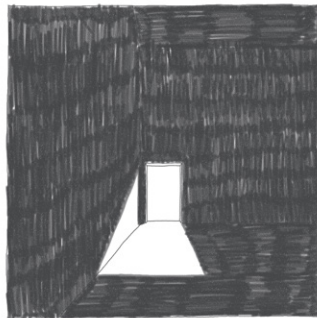
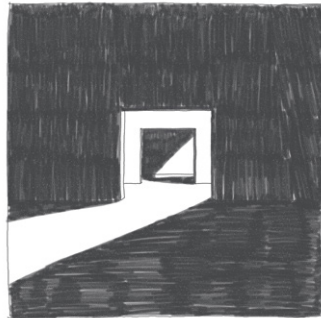
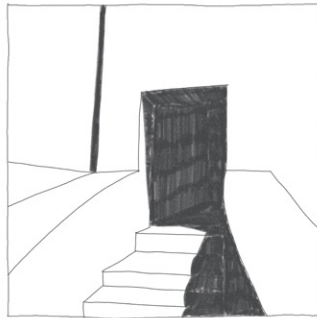
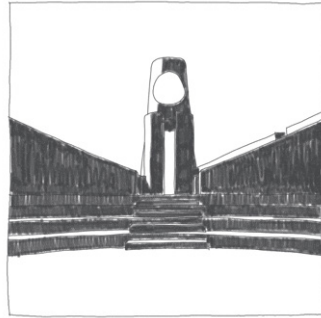
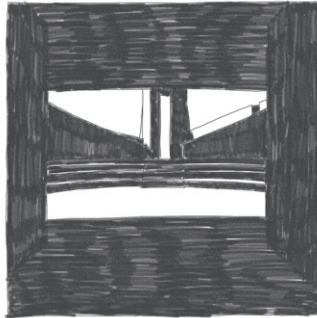
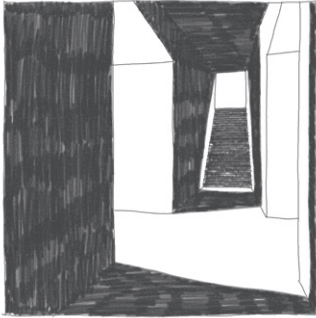

ITERATION 3. SIMPLE LINE AND SHADOW

walk (3)

layers of complexity (space, form and light)

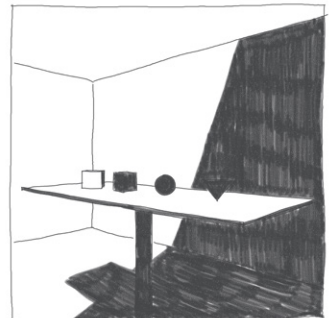
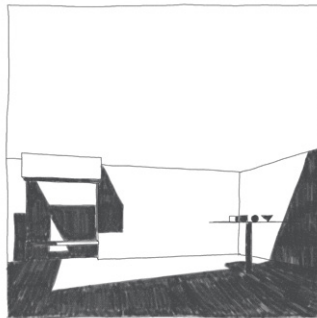
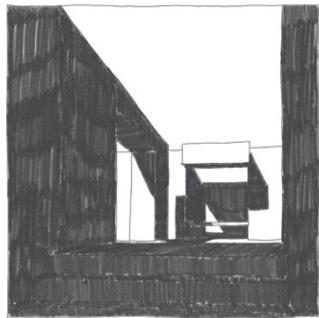
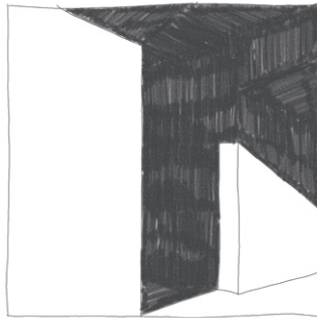
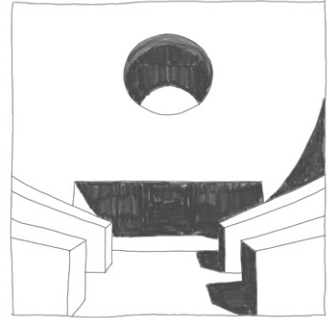
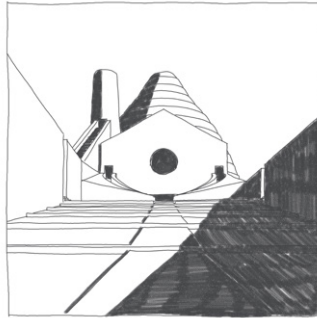

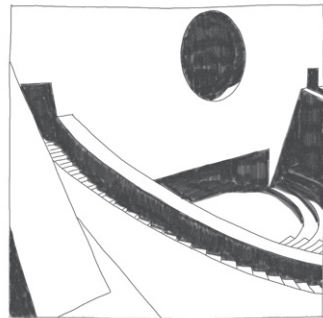
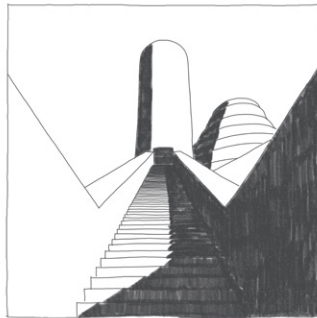
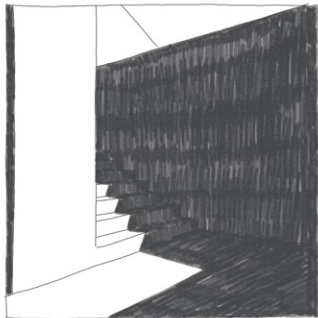
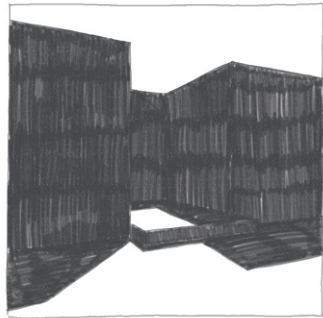
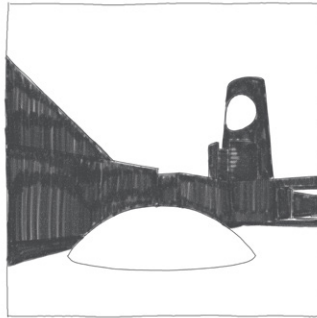
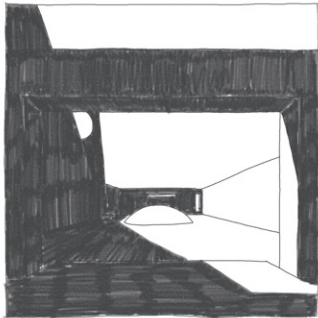
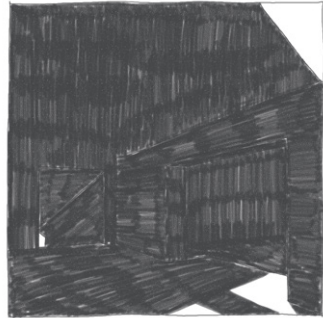
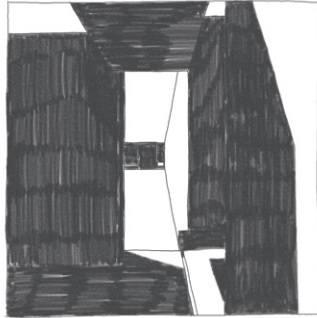
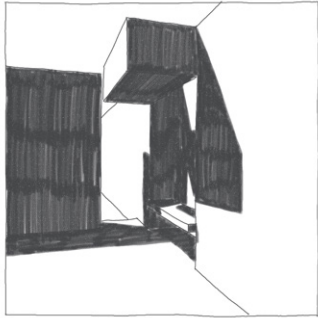

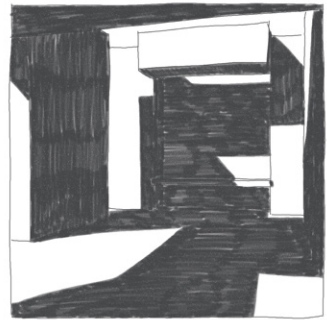
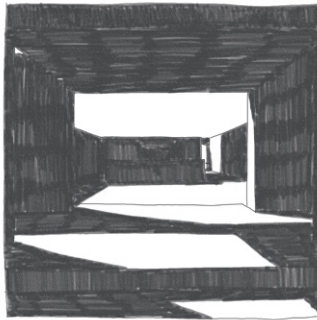
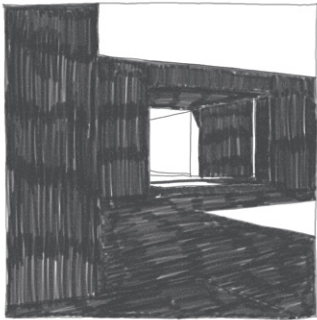
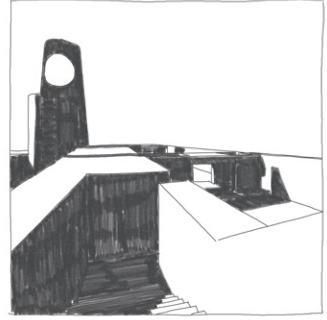
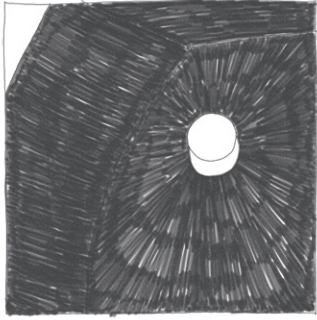
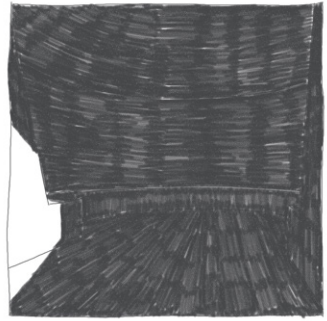
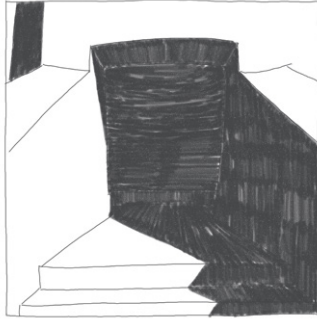

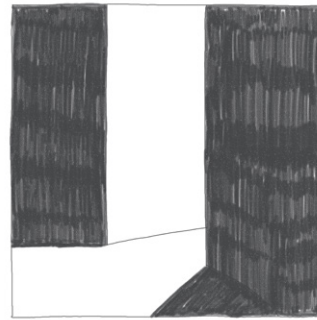
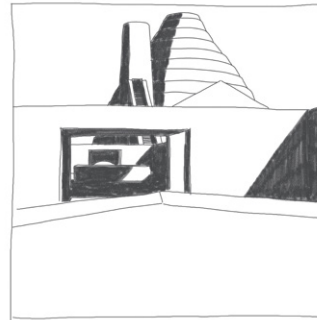
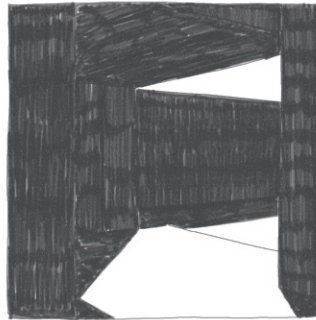
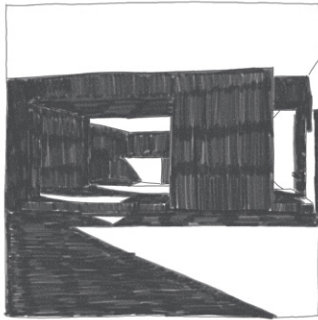
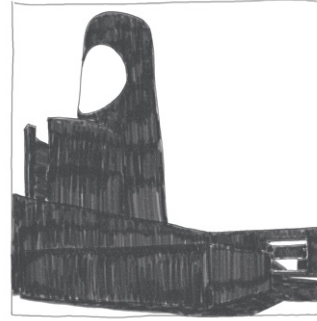
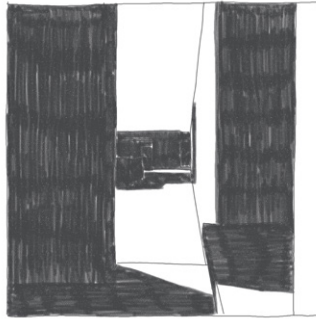
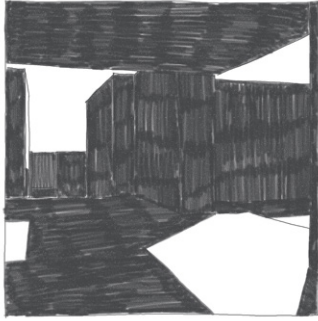

ITERATION 4. REFINED LINE

walk (1)

layers of complexity (space and form)

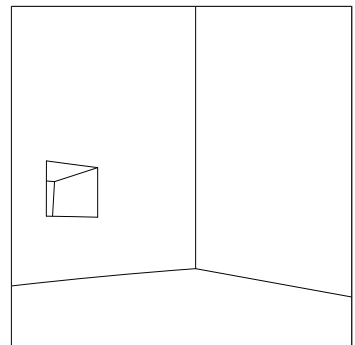
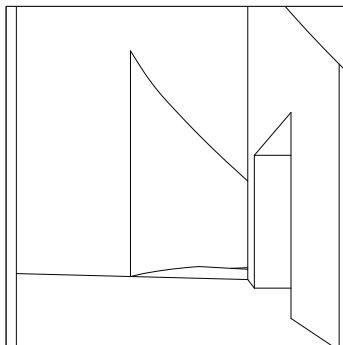
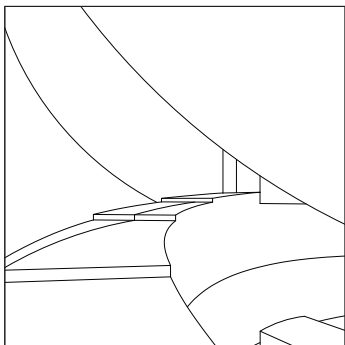
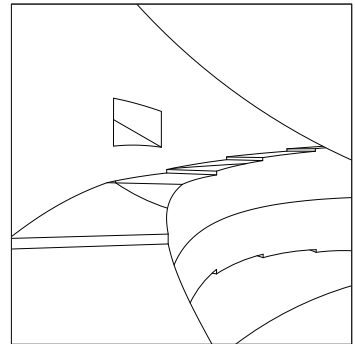
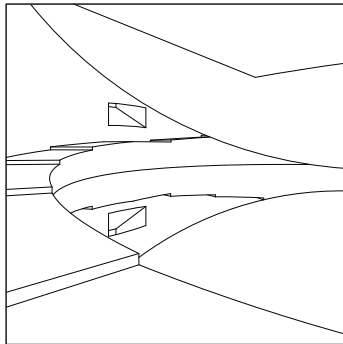
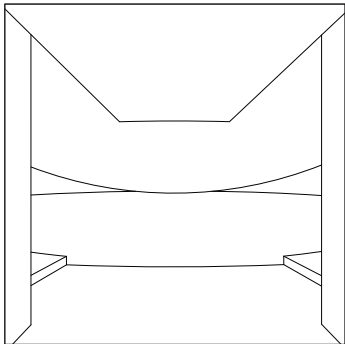
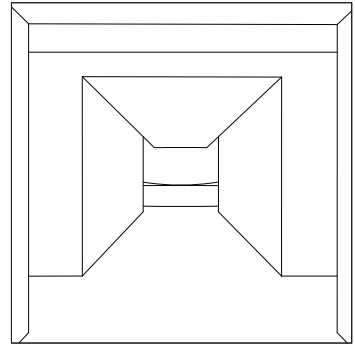
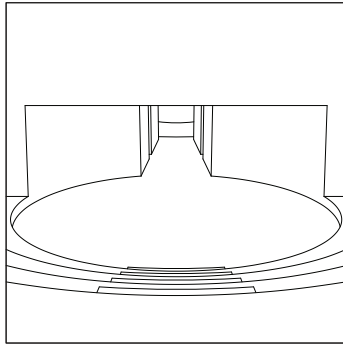
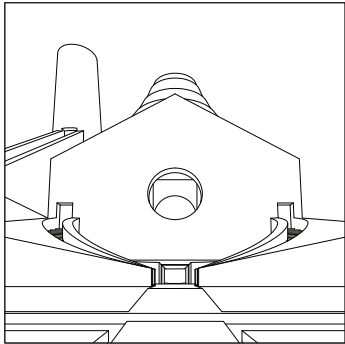

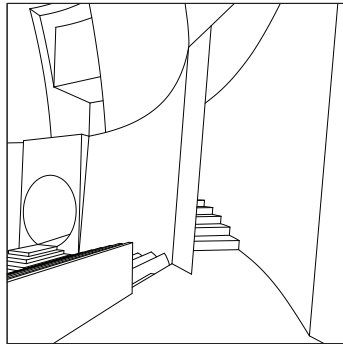
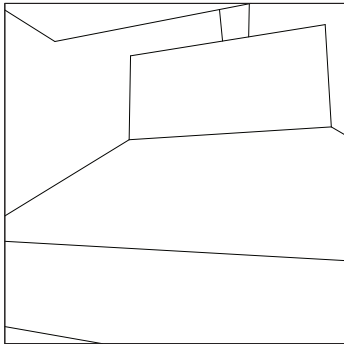
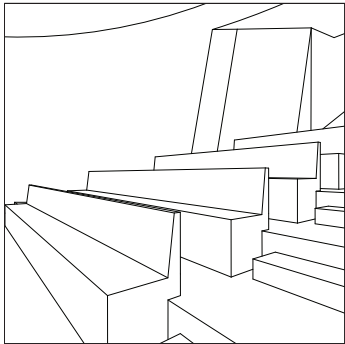
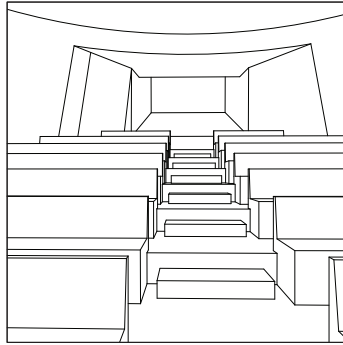
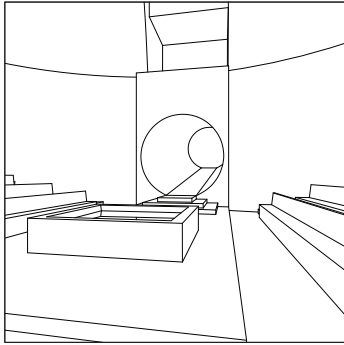
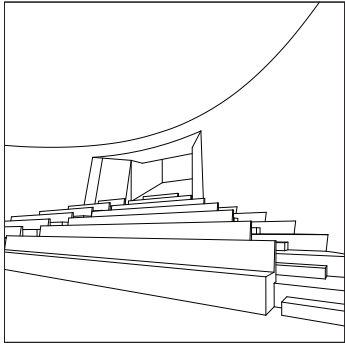
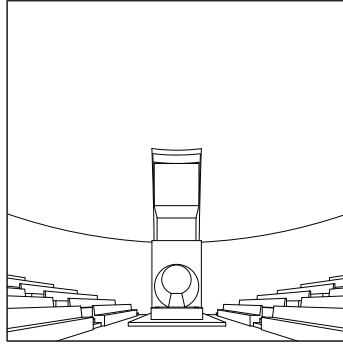
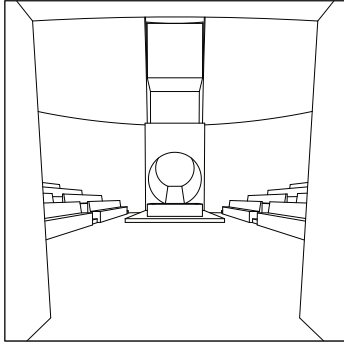
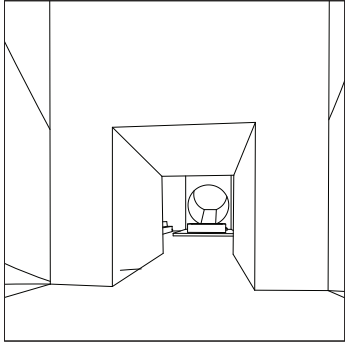

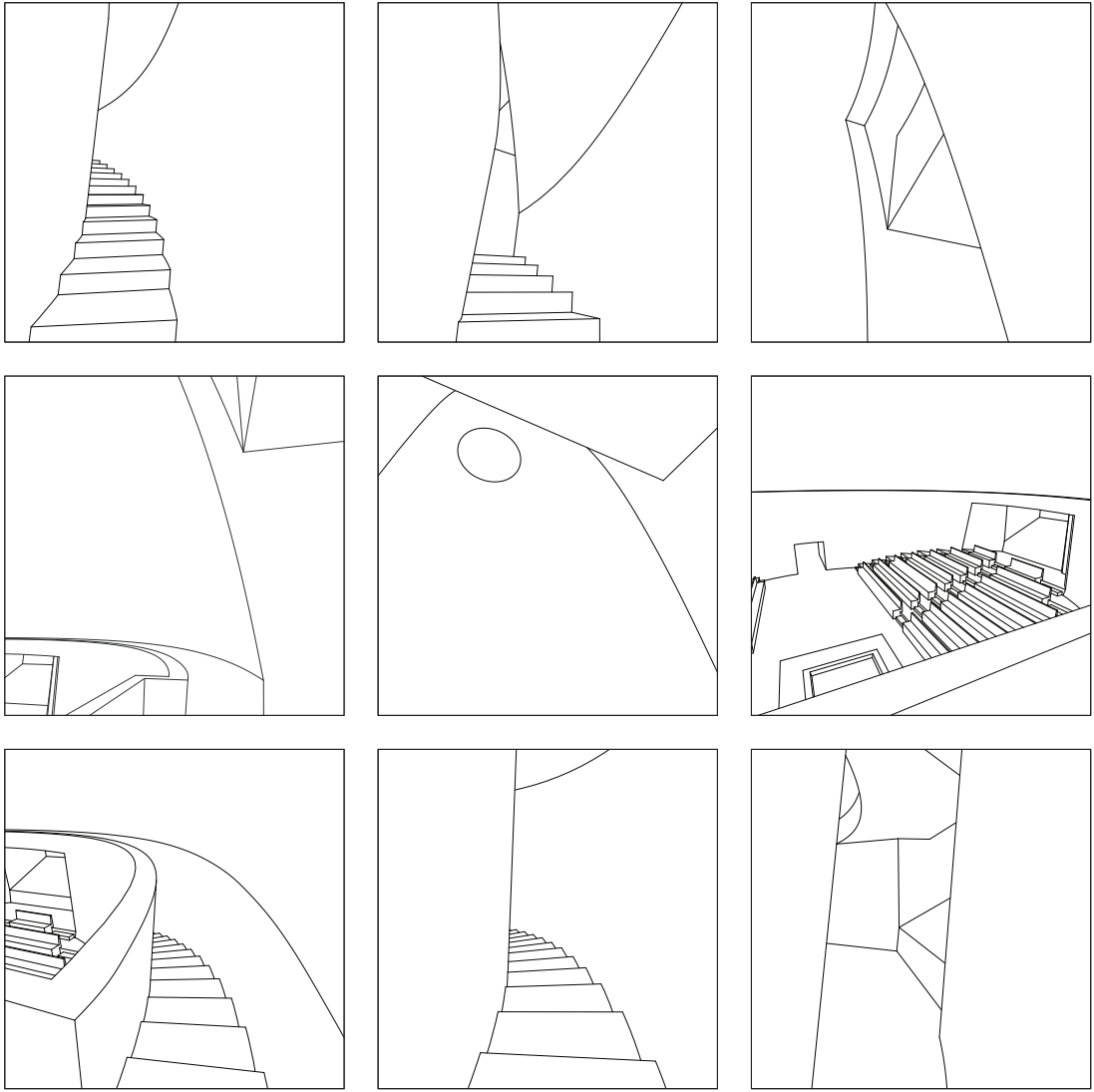

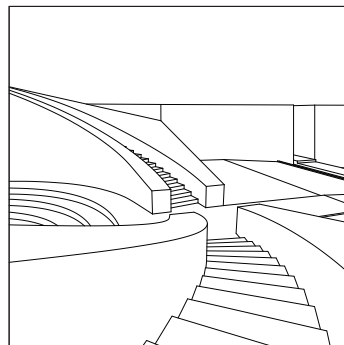
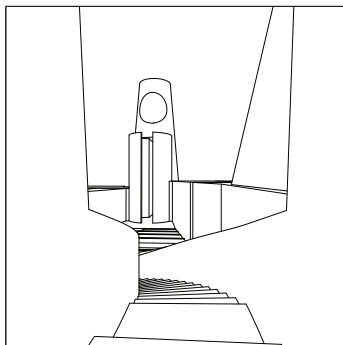
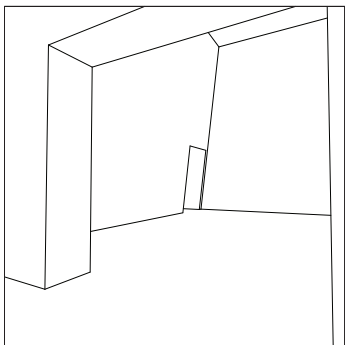
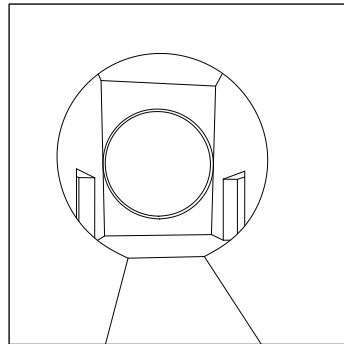
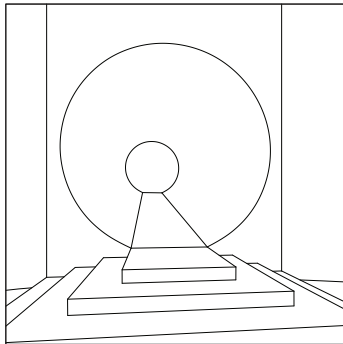
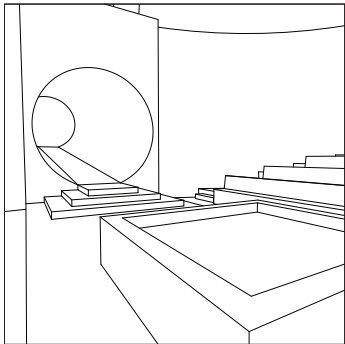
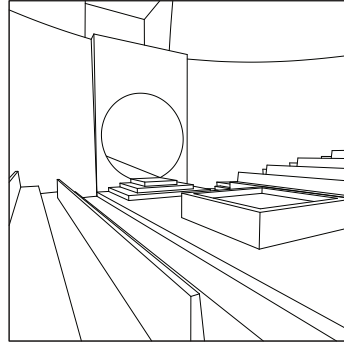
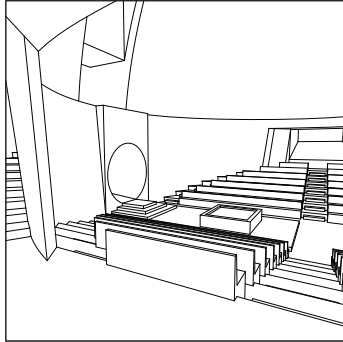
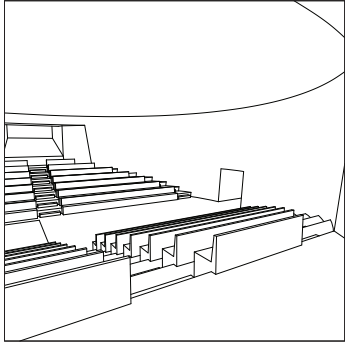

ITERATION 4. REFINED LINE

walk (2)

layers of complexity (space and form)

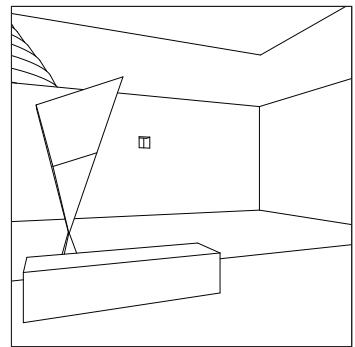
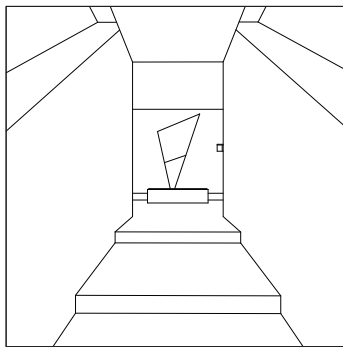
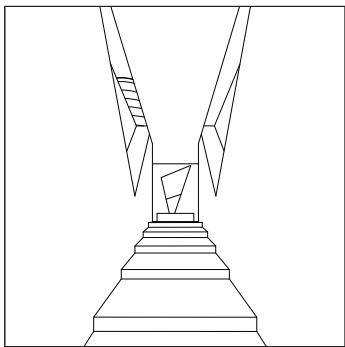
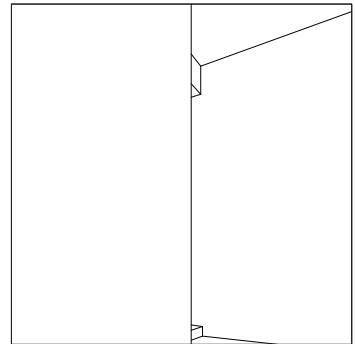
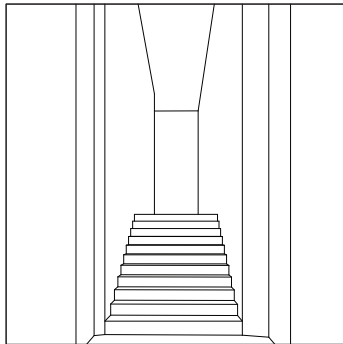
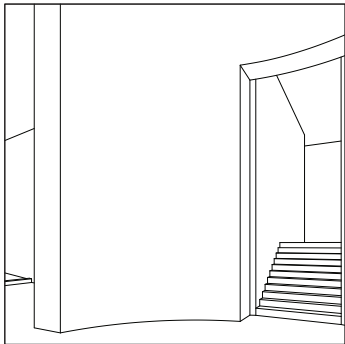
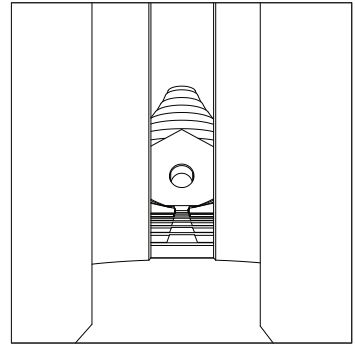
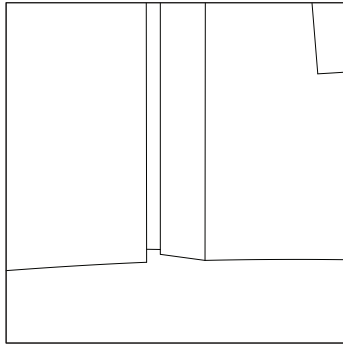
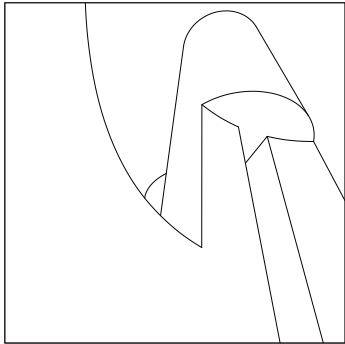

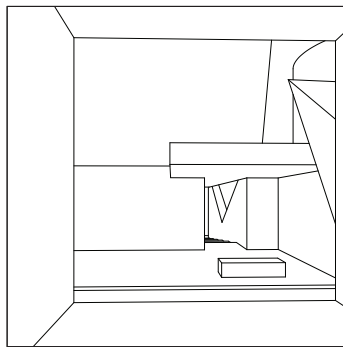
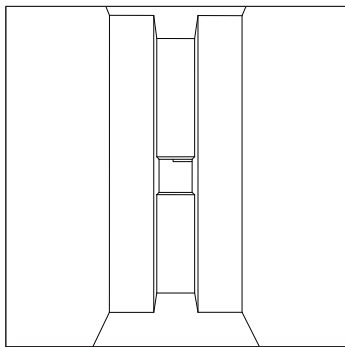
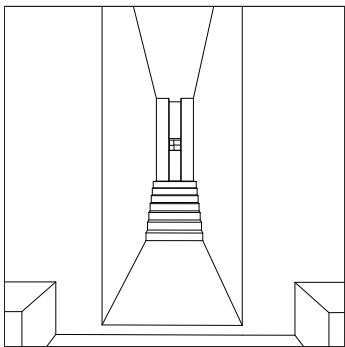
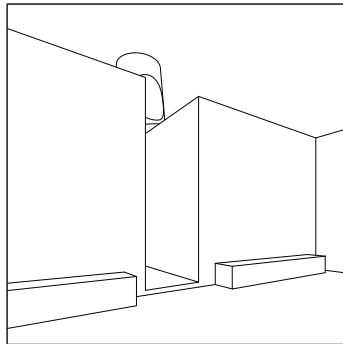
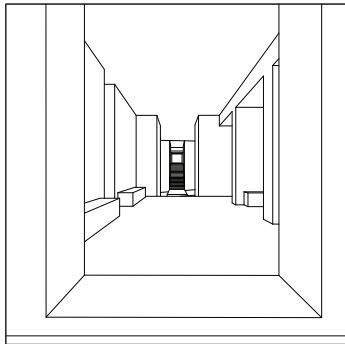
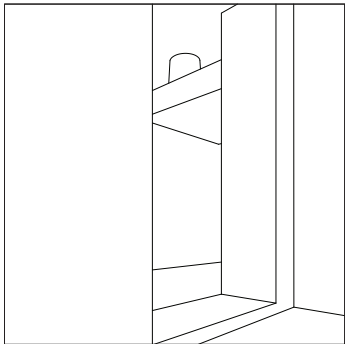
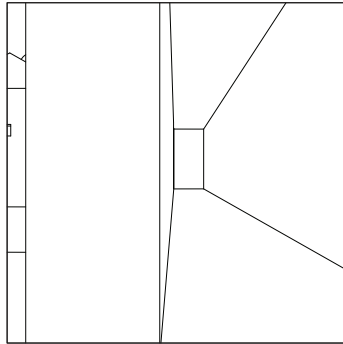
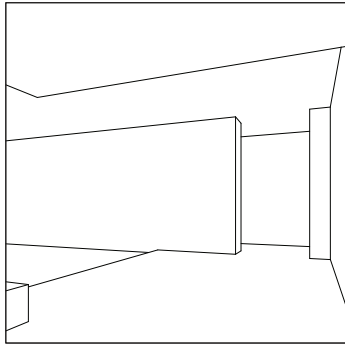
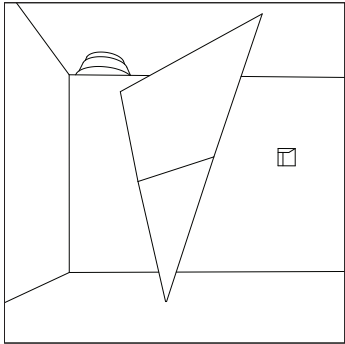

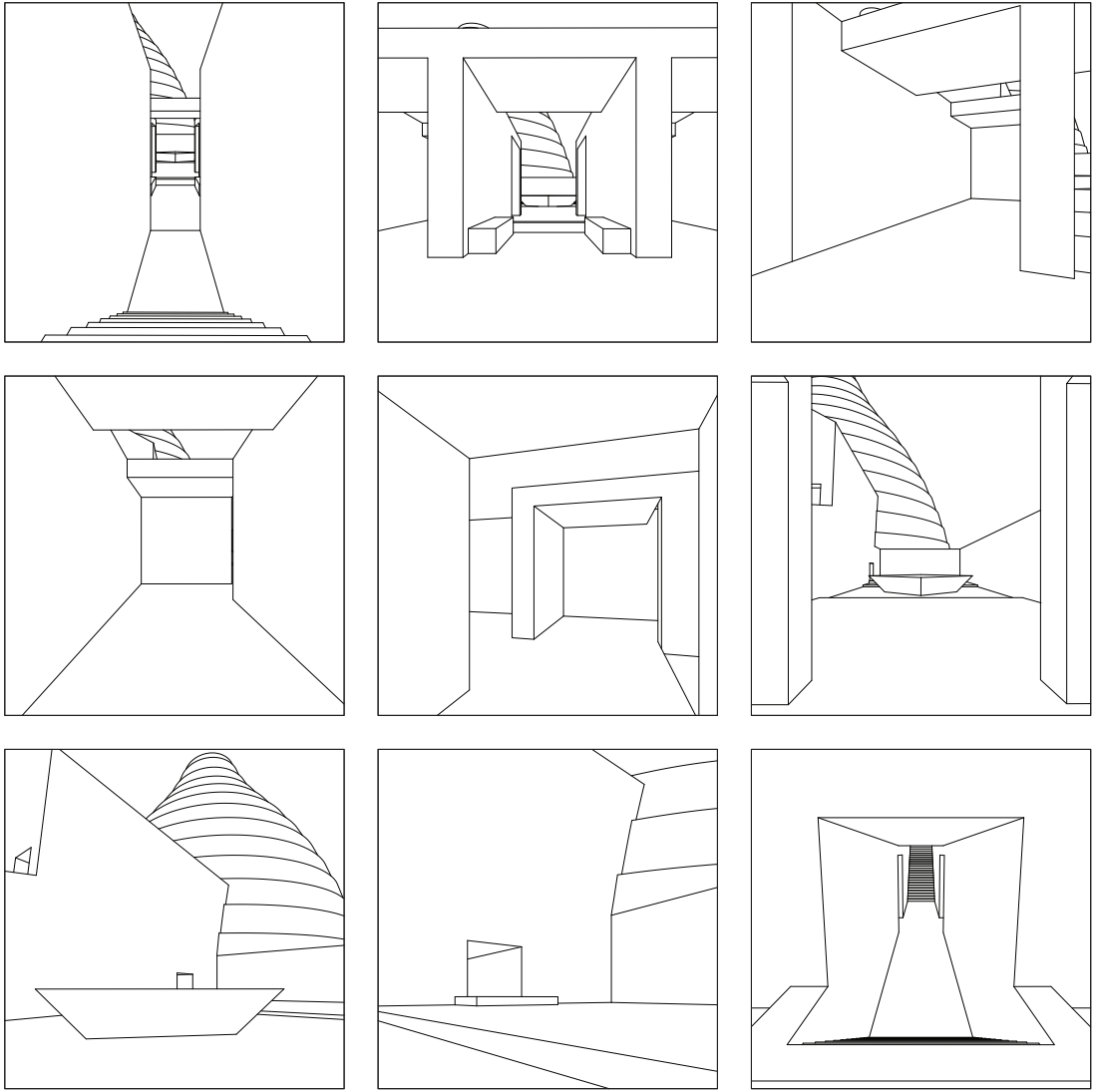

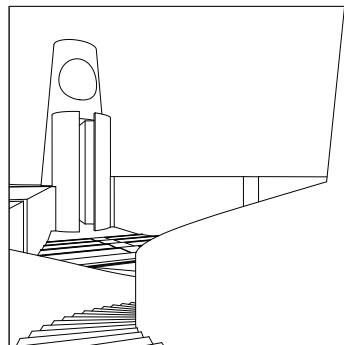
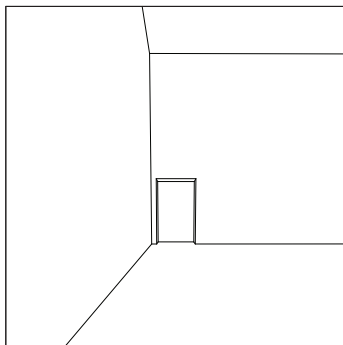
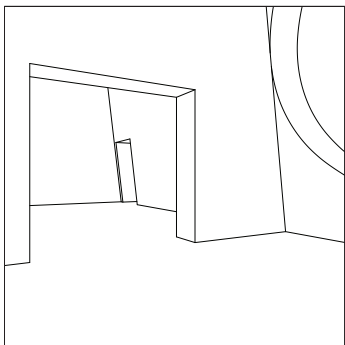
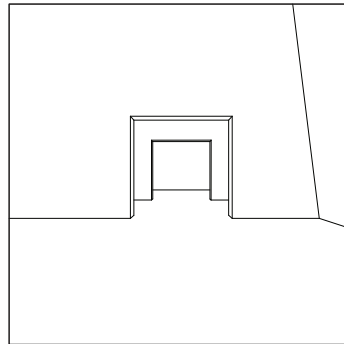
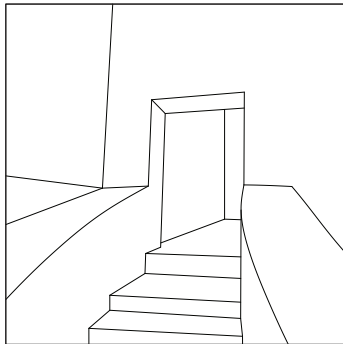
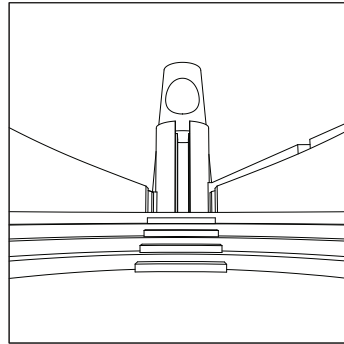
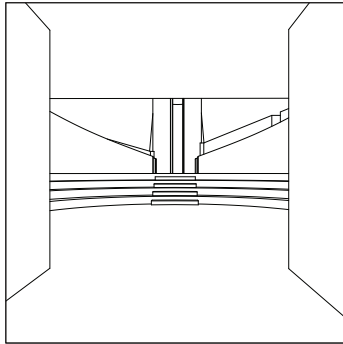
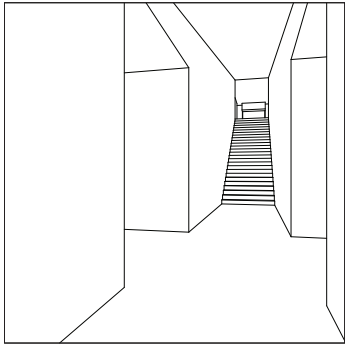

ITERATION 4. REFINED LINE

walk (3)

layers of complexity (space and form)

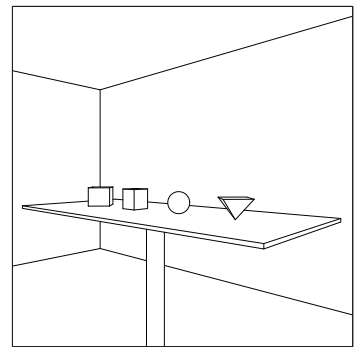
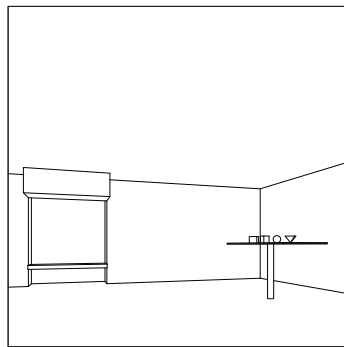
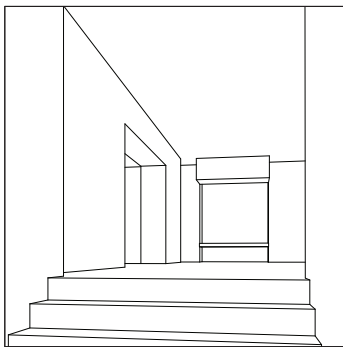
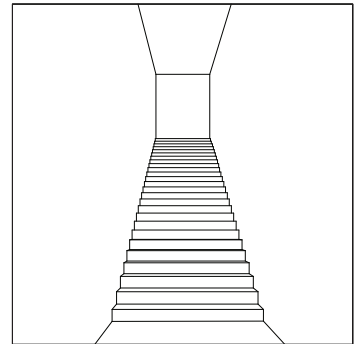
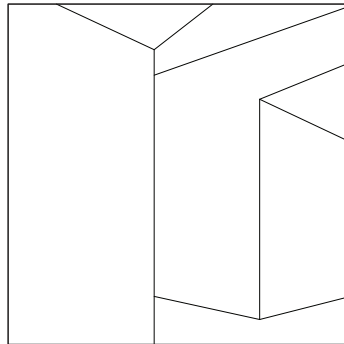
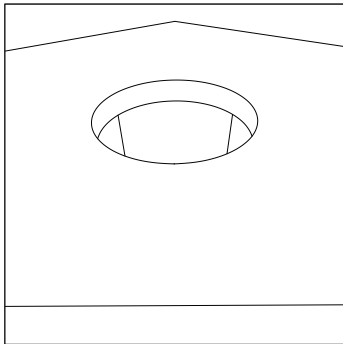
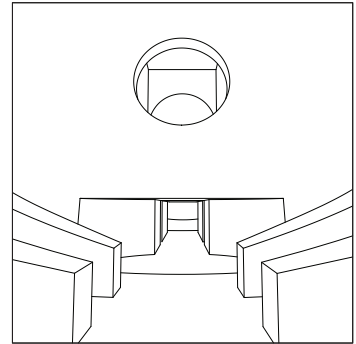
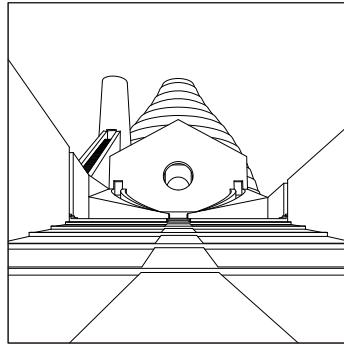
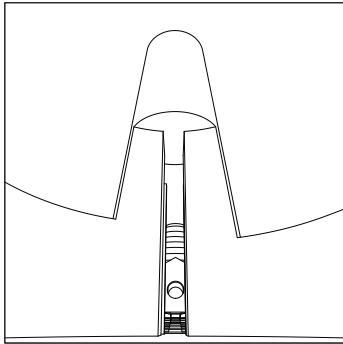

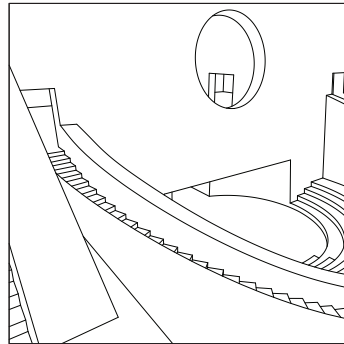
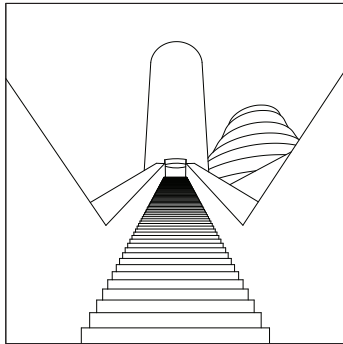
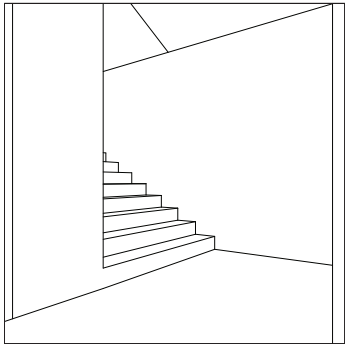
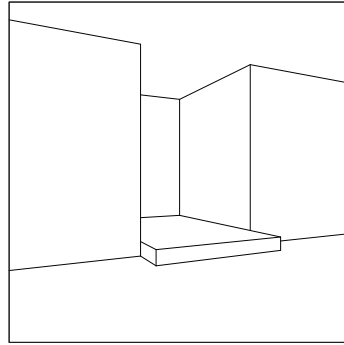
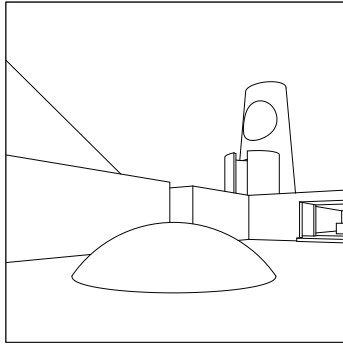
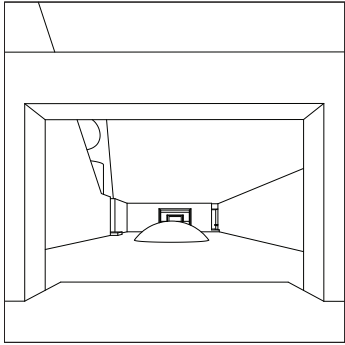
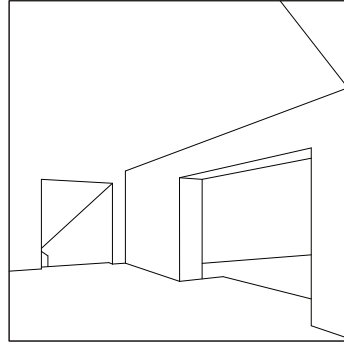
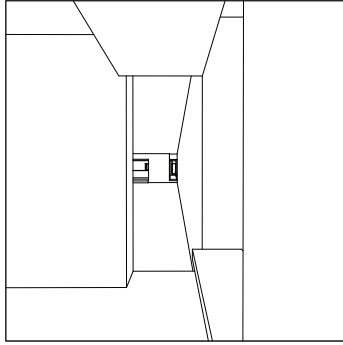
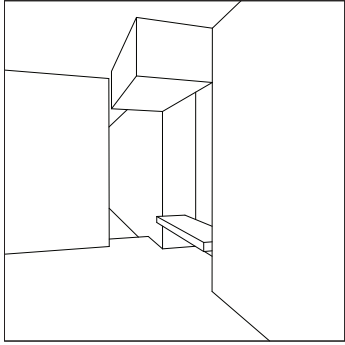

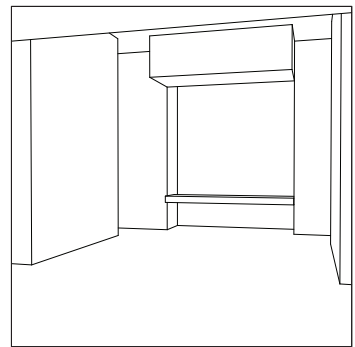
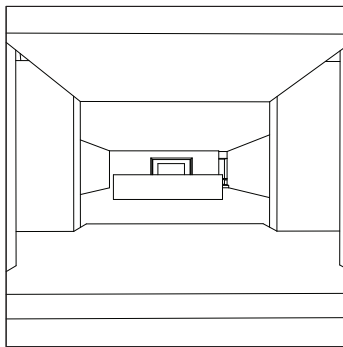
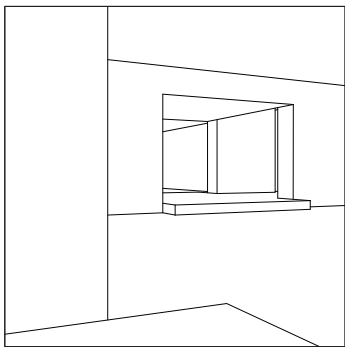
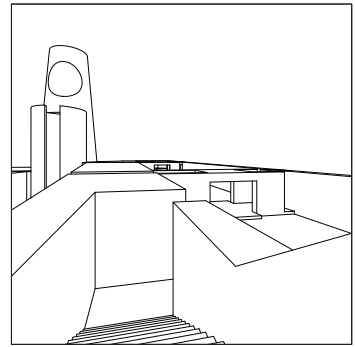
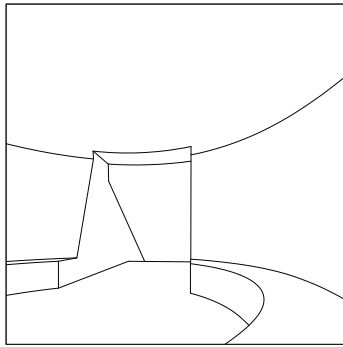
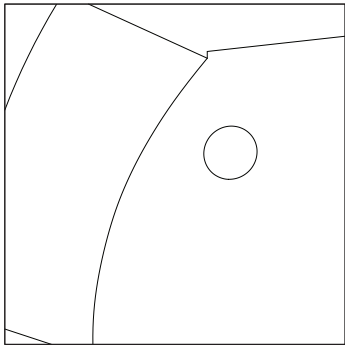
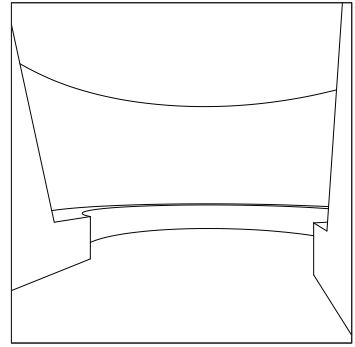
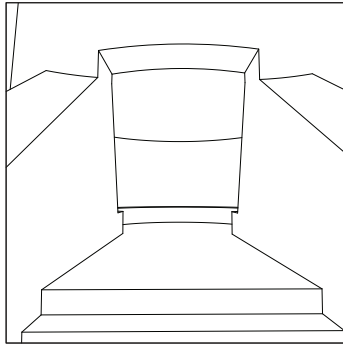
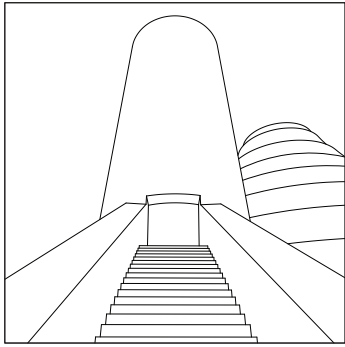

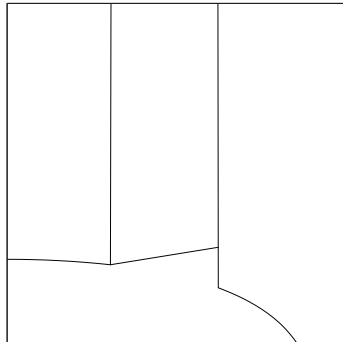
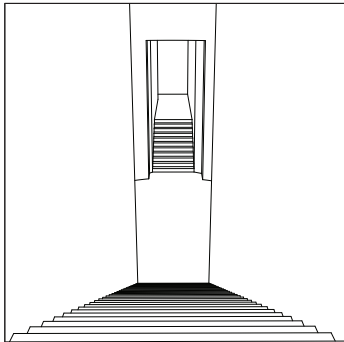
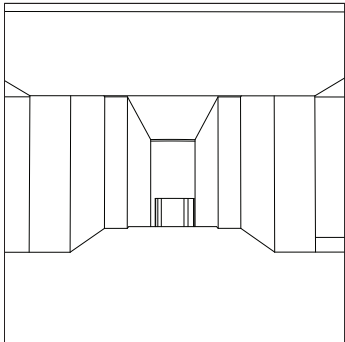
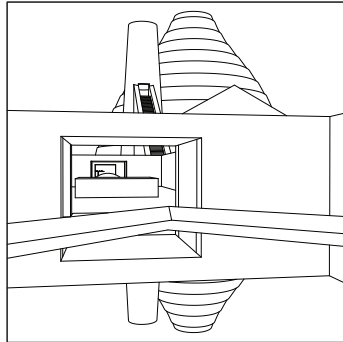
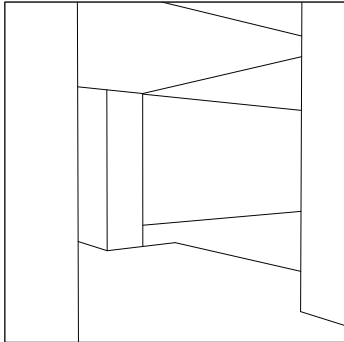
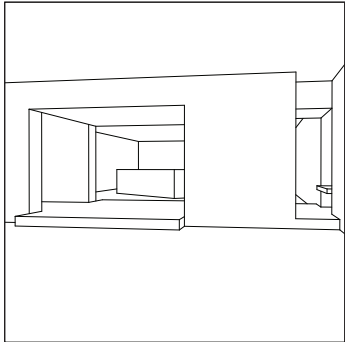
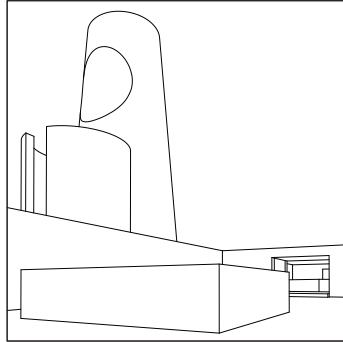
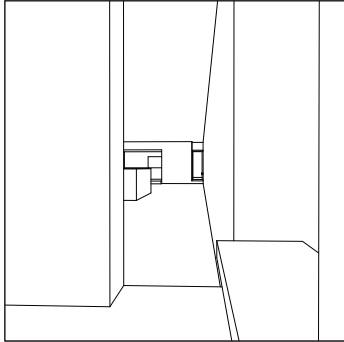
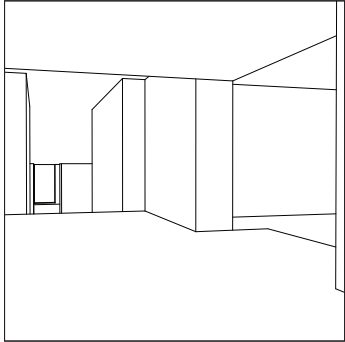

ITERATION 5. REFINED LINE AND SHADOW

walk (1)

layers of complexity (space, form and light)

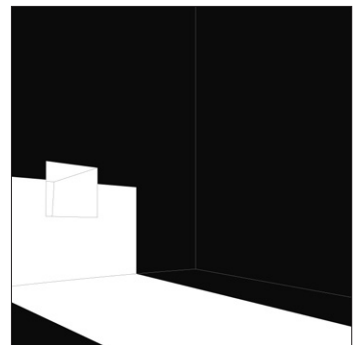
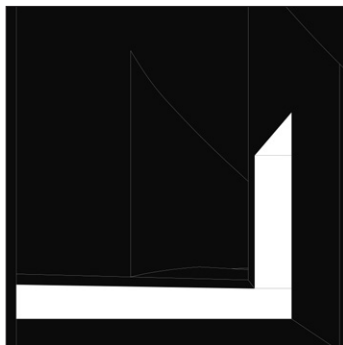
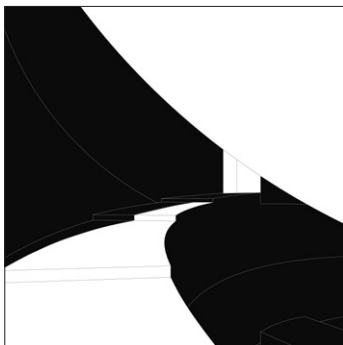
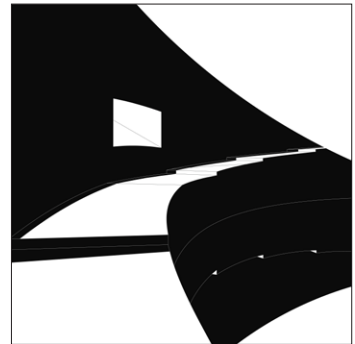
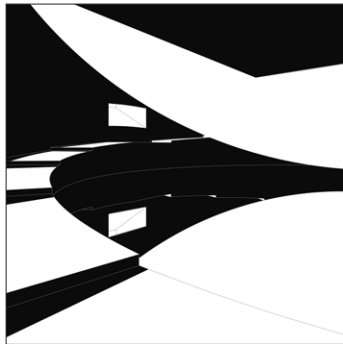
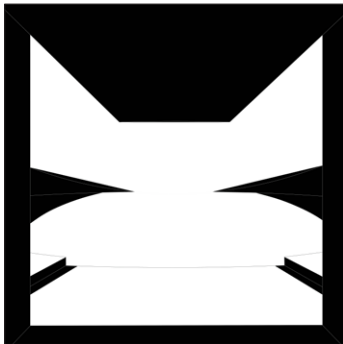
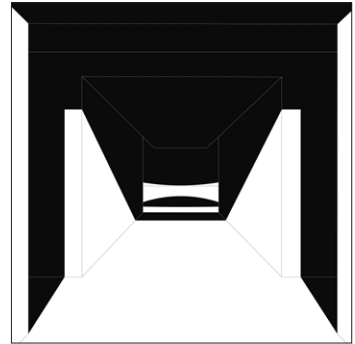
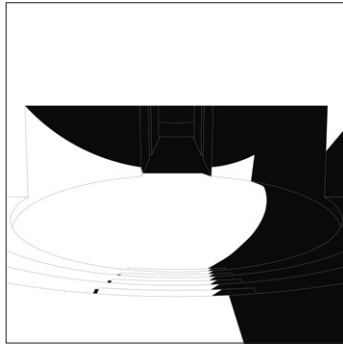
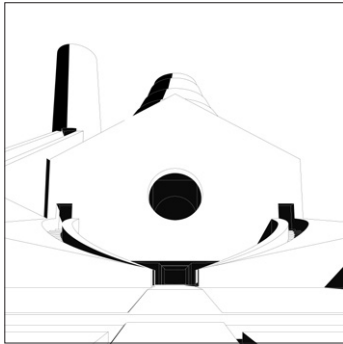

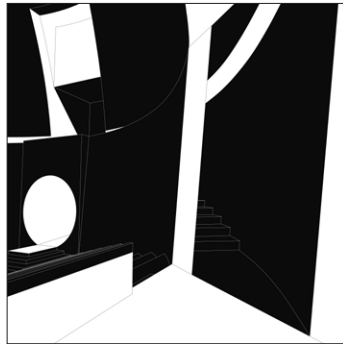
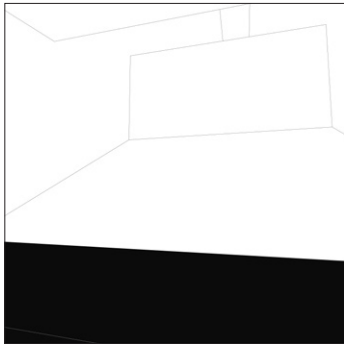
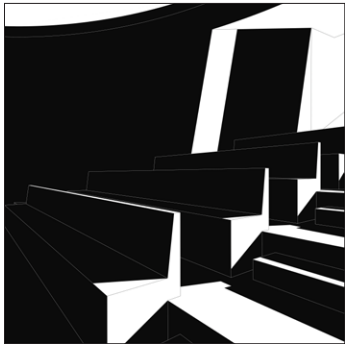
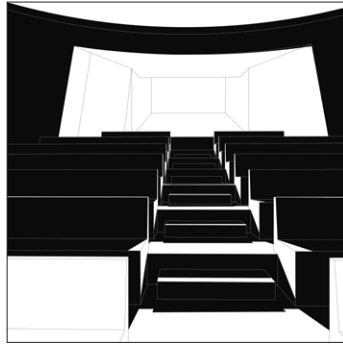
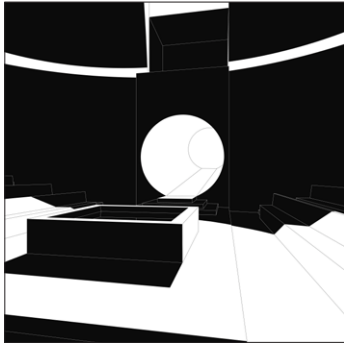
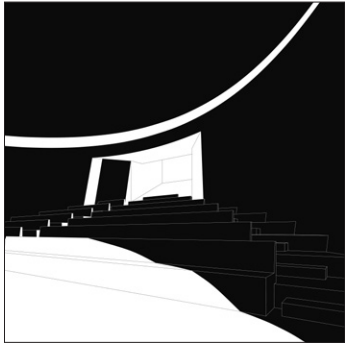
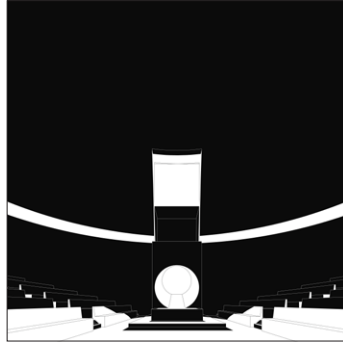
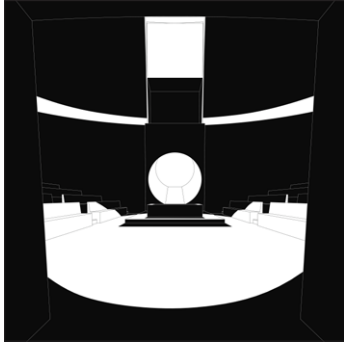
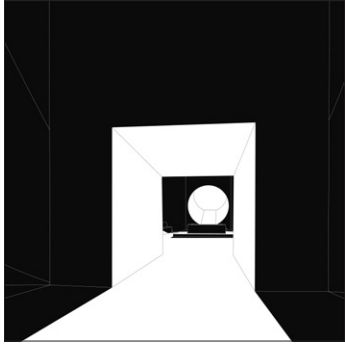



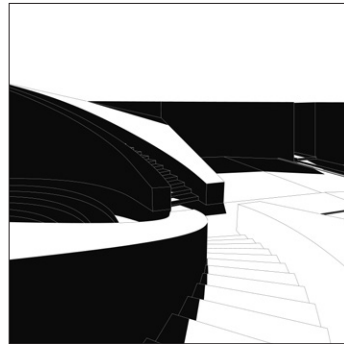
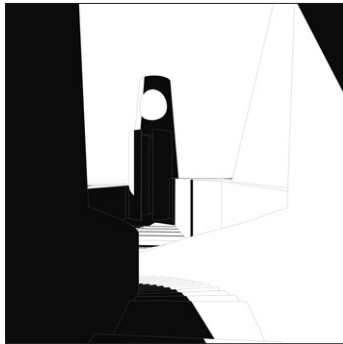
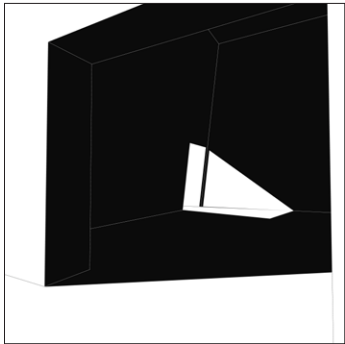
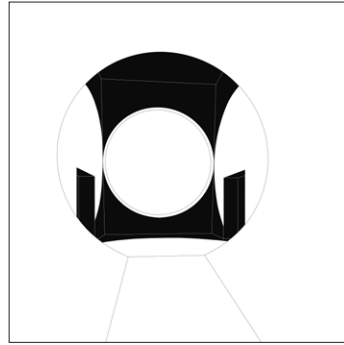
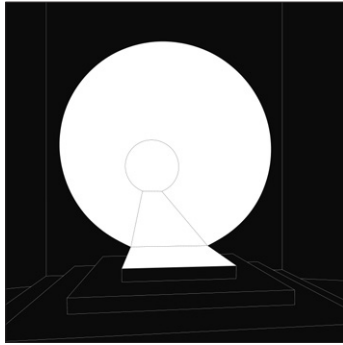
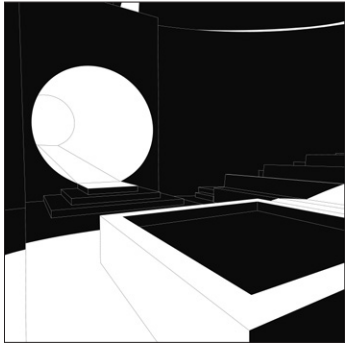
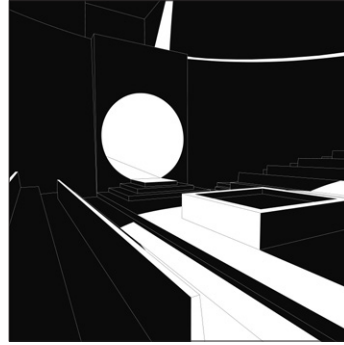
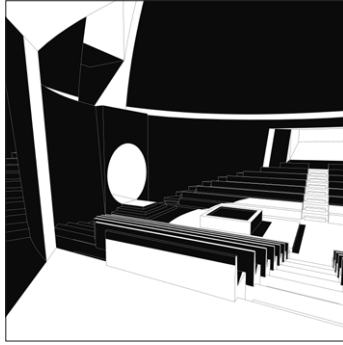
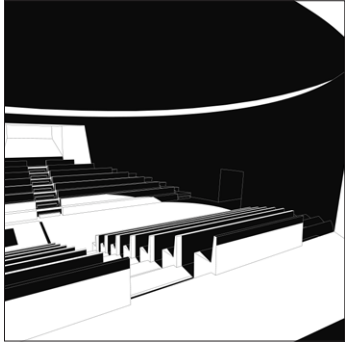

ITERATION 5. REFINED LINE AND SHADOW

walk (2)

layers of complexity (space, form and light)

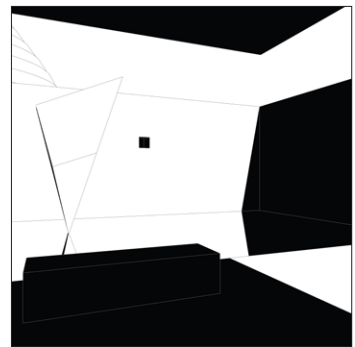
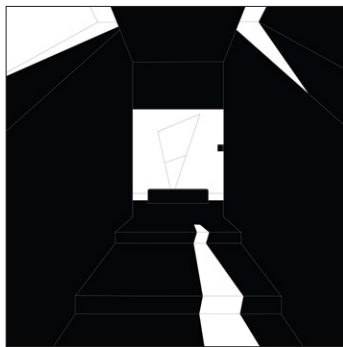
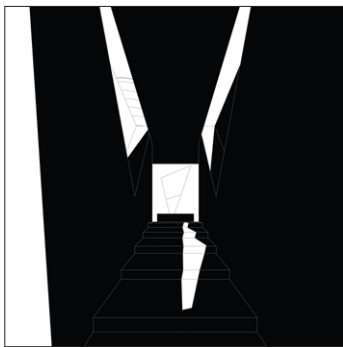
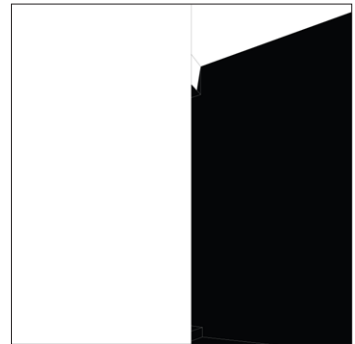
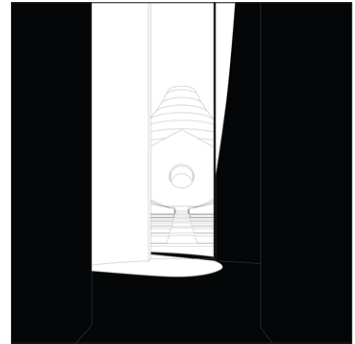
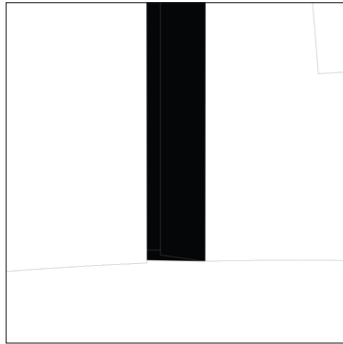
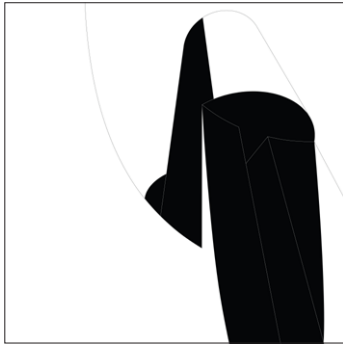

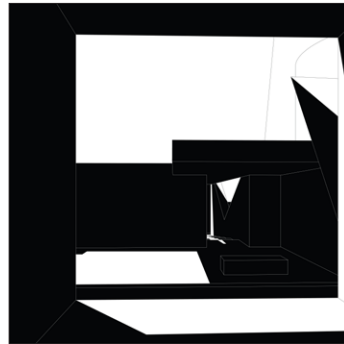
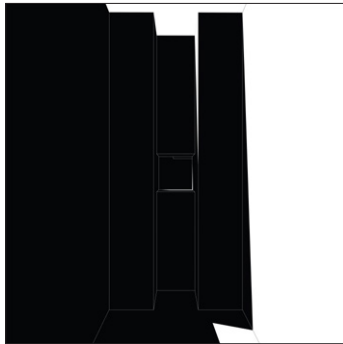
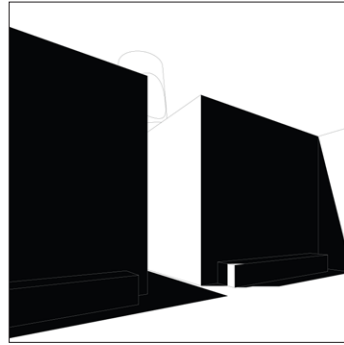
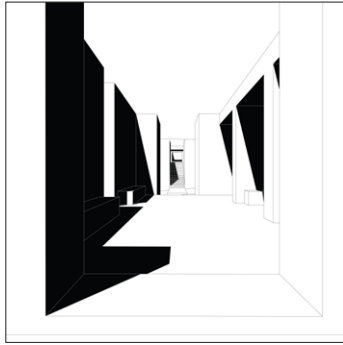
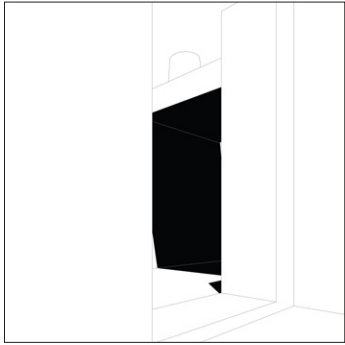
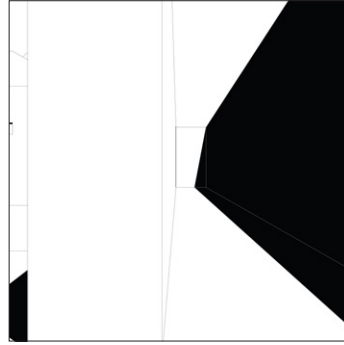
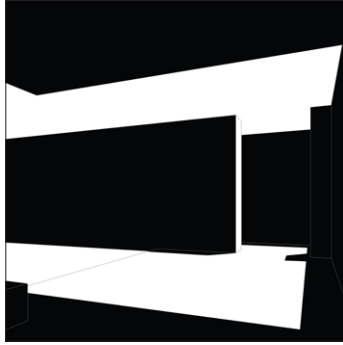
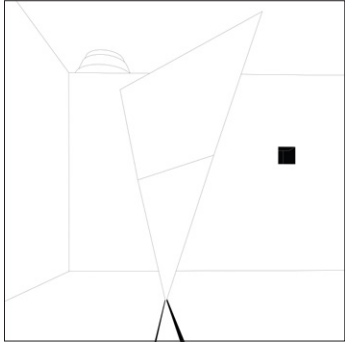

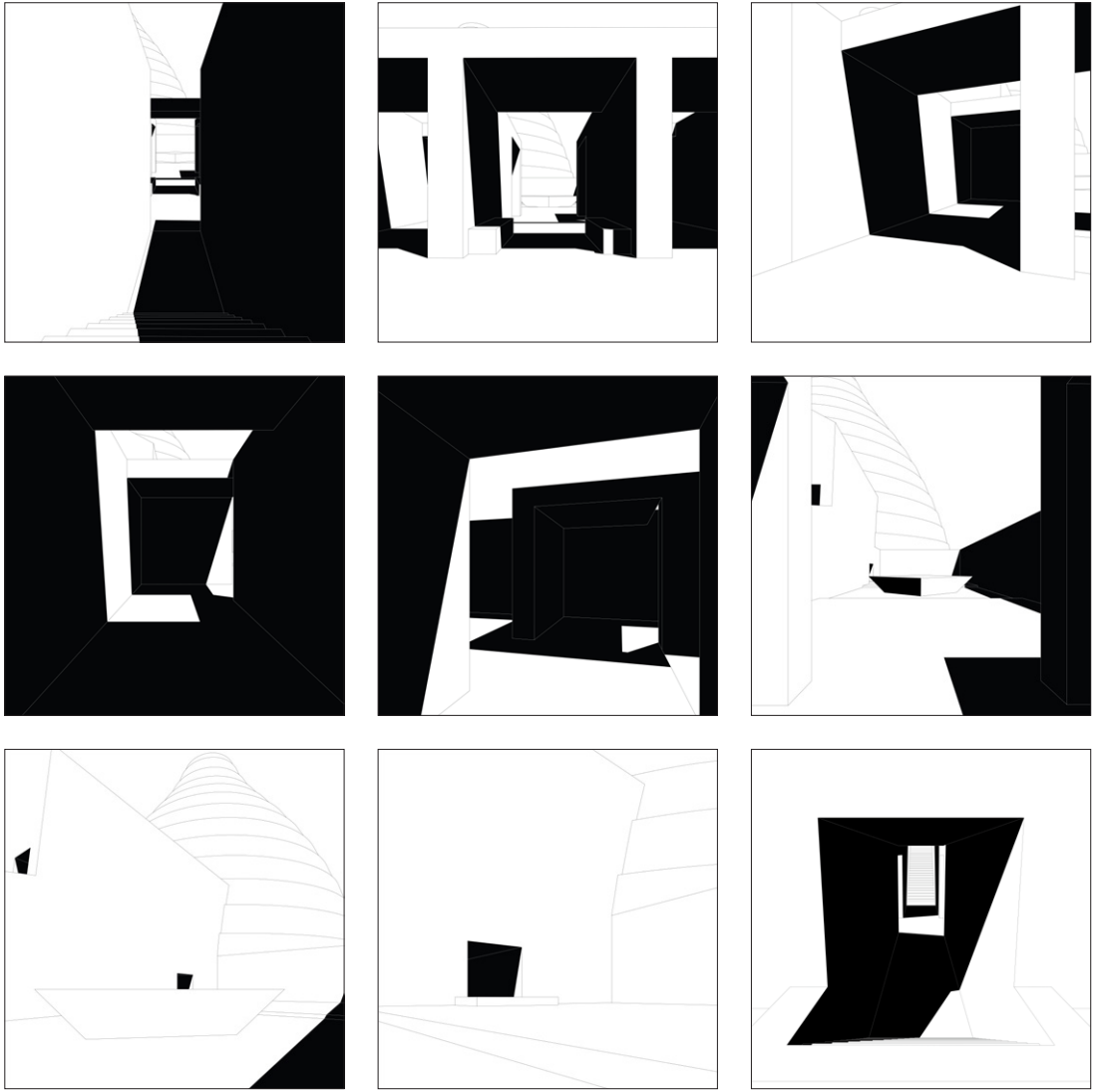

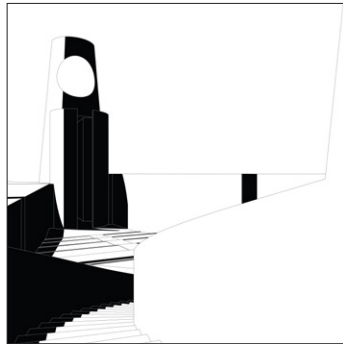
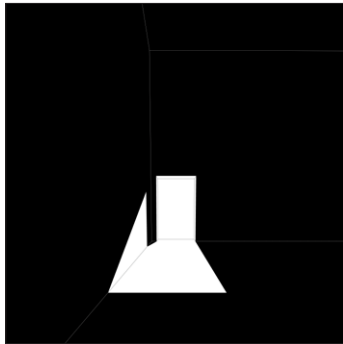
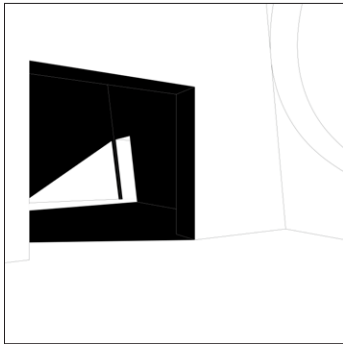
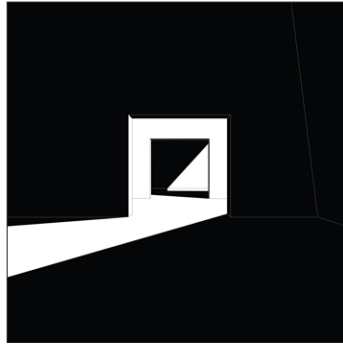
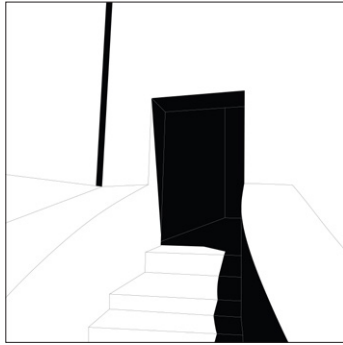
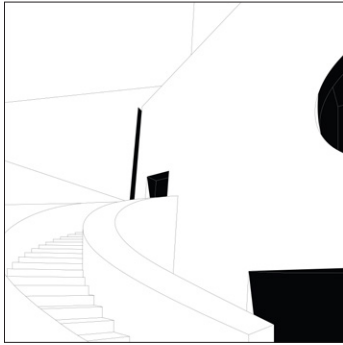
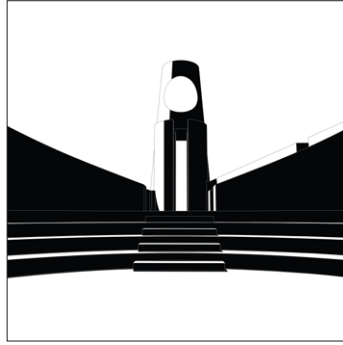
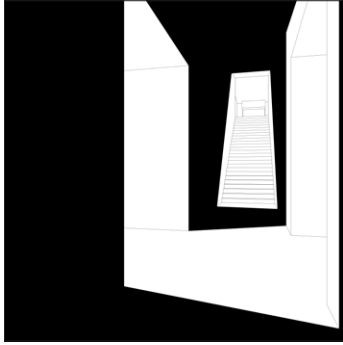

ITERATION 5. REFINED LINE AND SHADOW

walk (3)

layers of complexity (space, form and light)

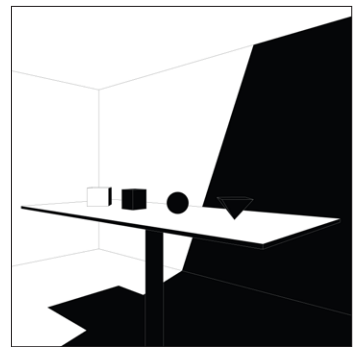
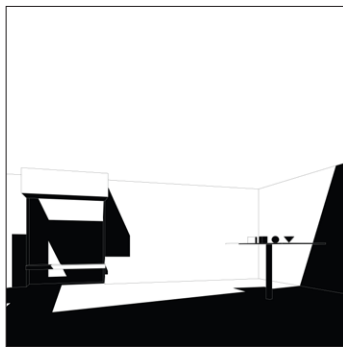
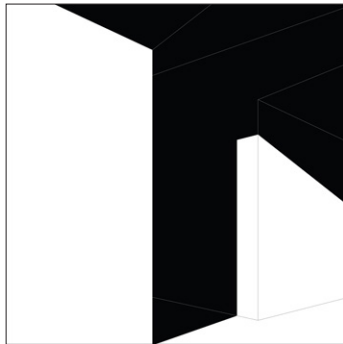
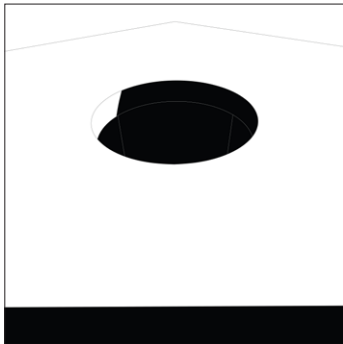
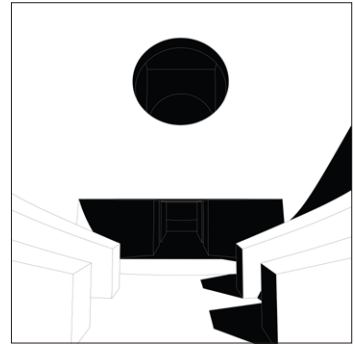
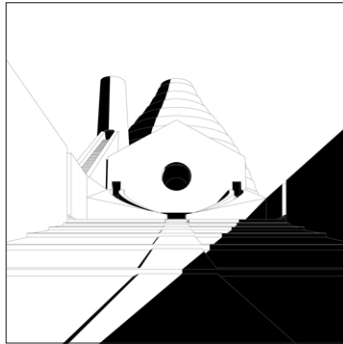
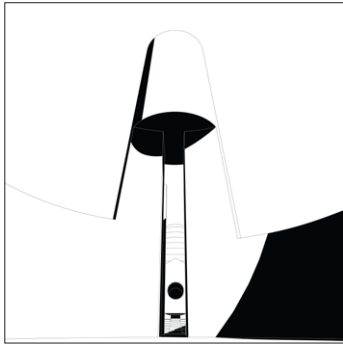

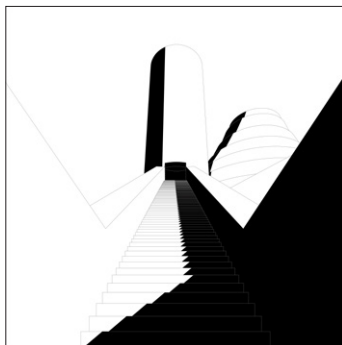
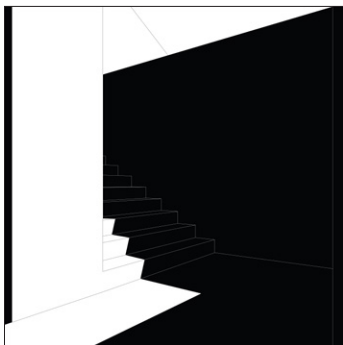
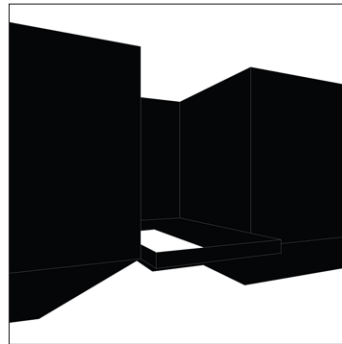
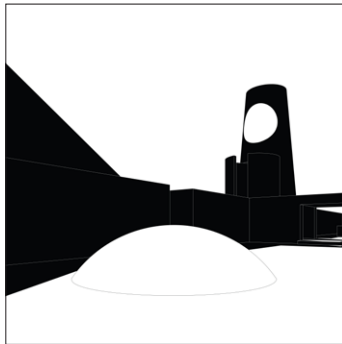
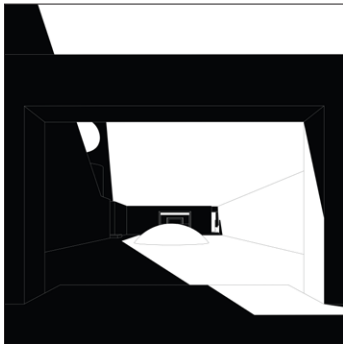
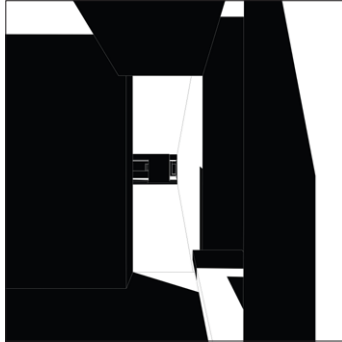
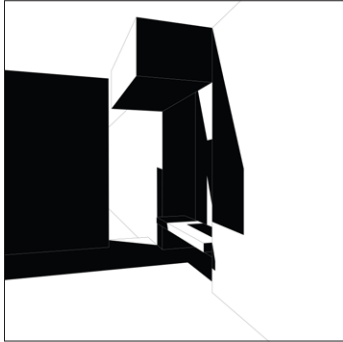

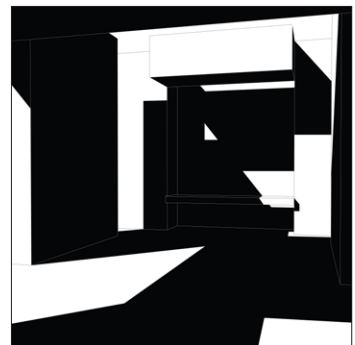
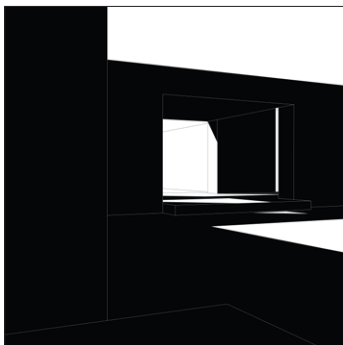
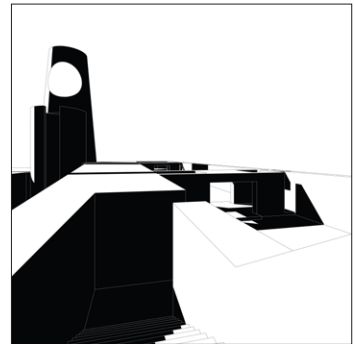
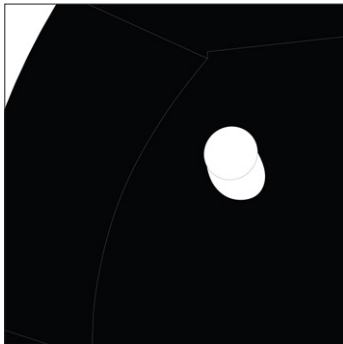
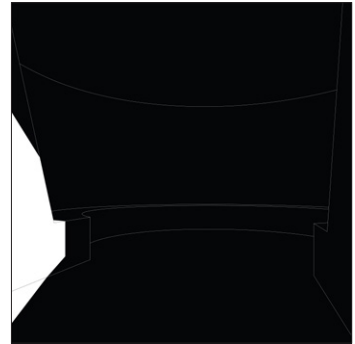
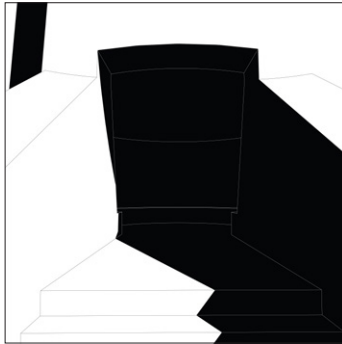
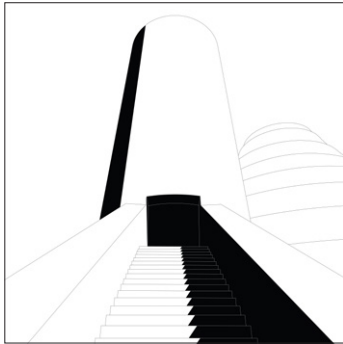

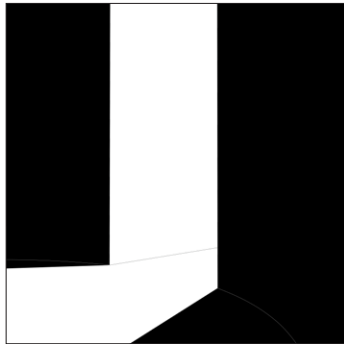
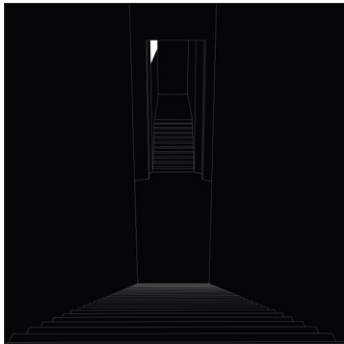
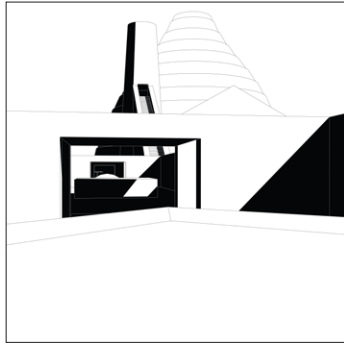
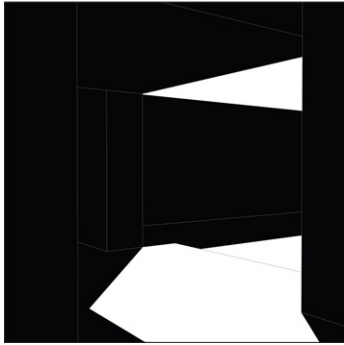
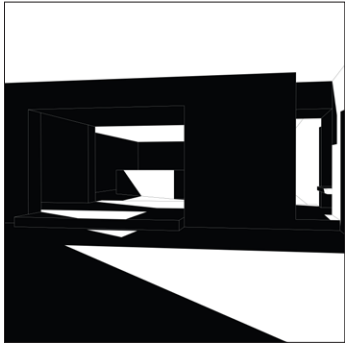
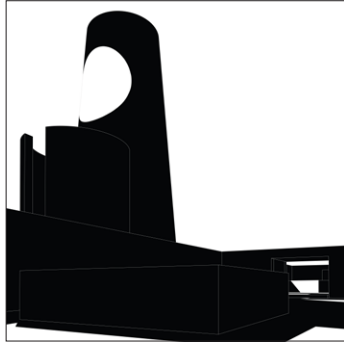
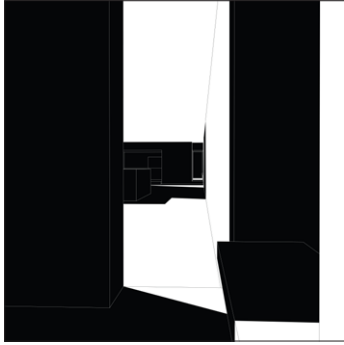
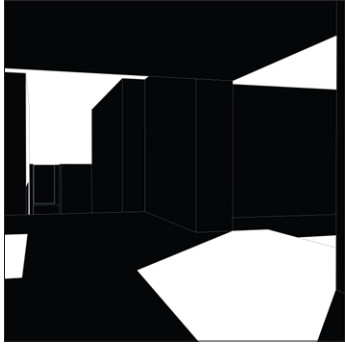

ITERATION 6. COLOR

walk (1)

layers of complexity (space, form, light
and color)

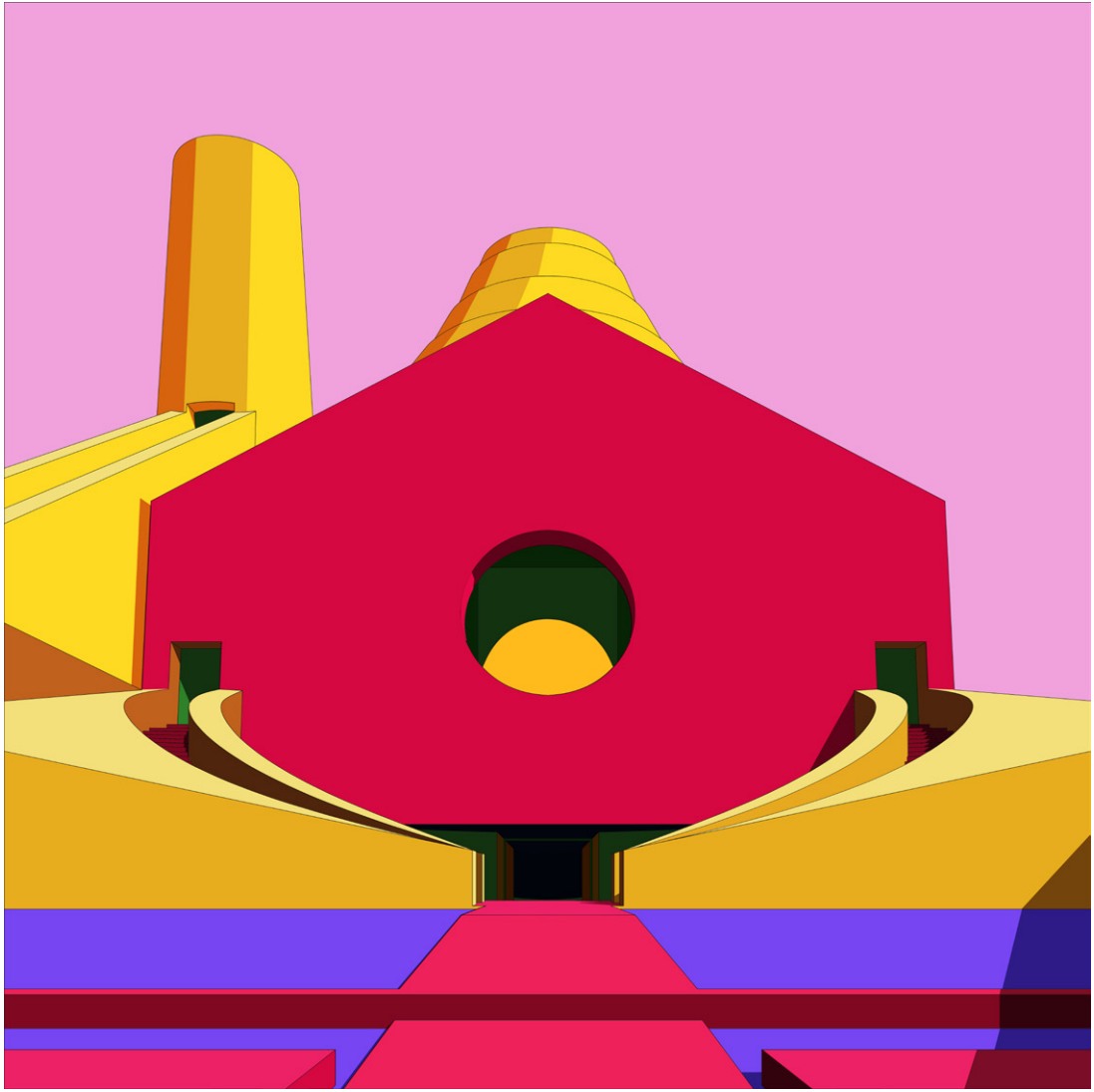



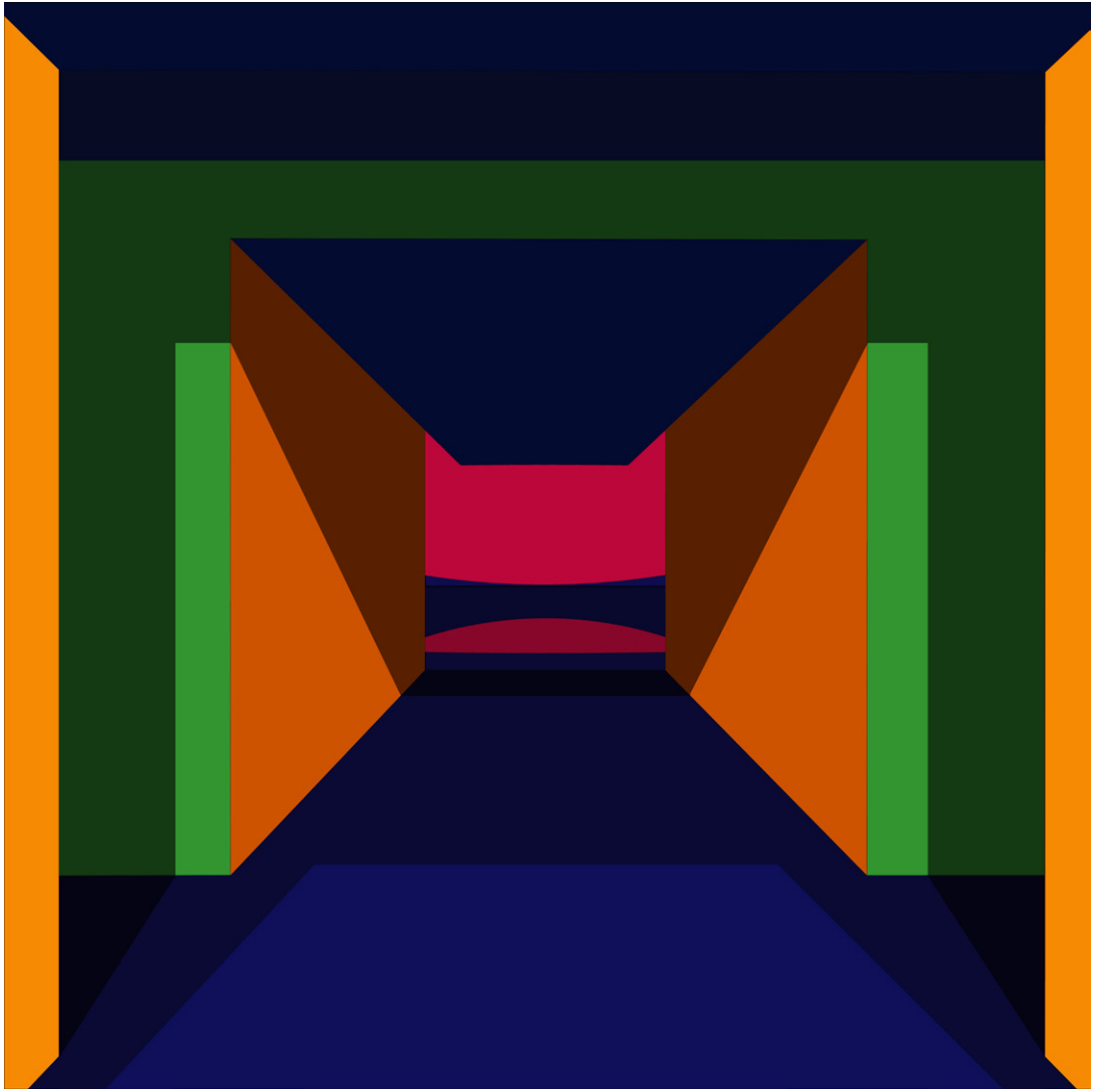

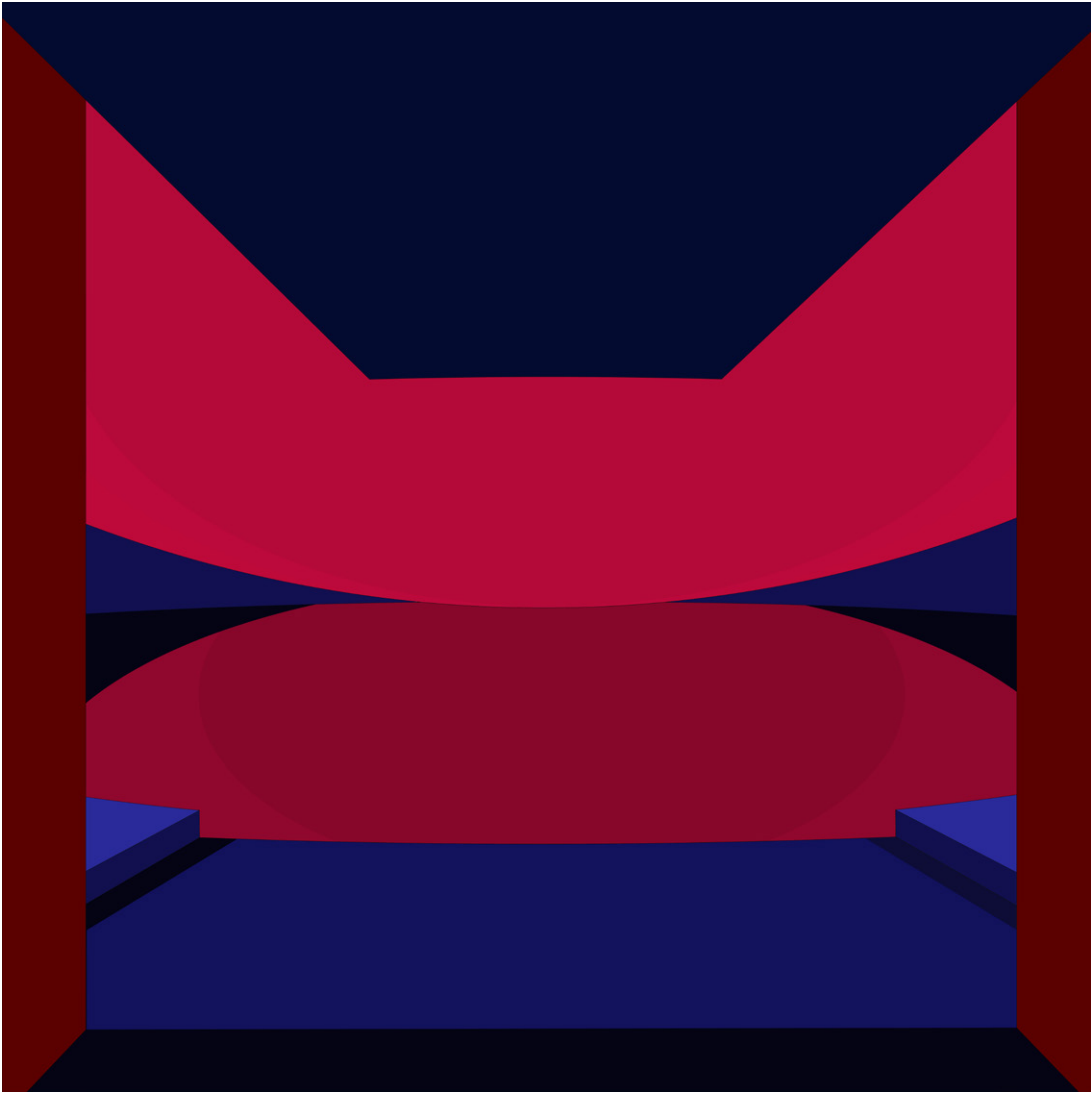

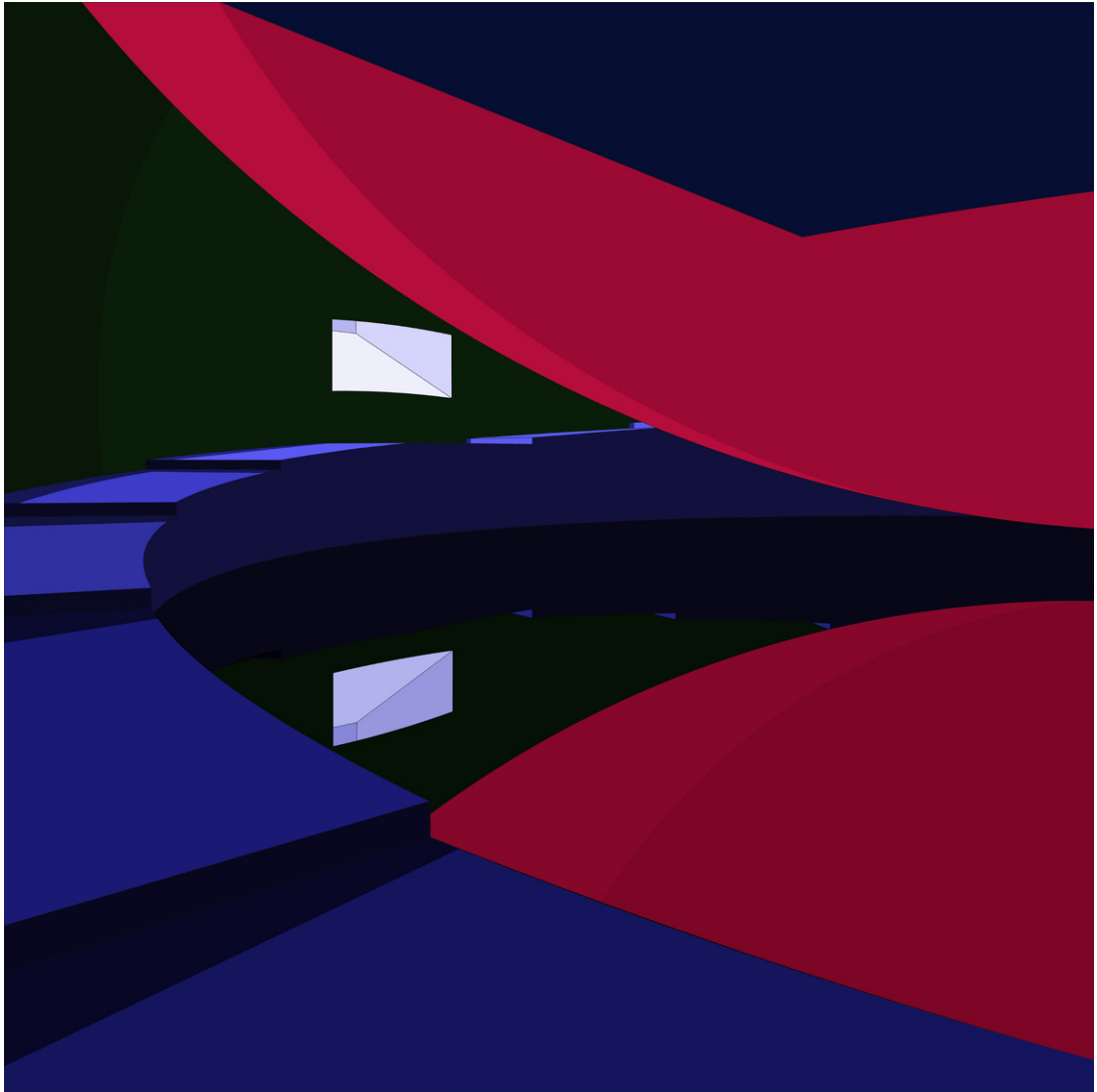

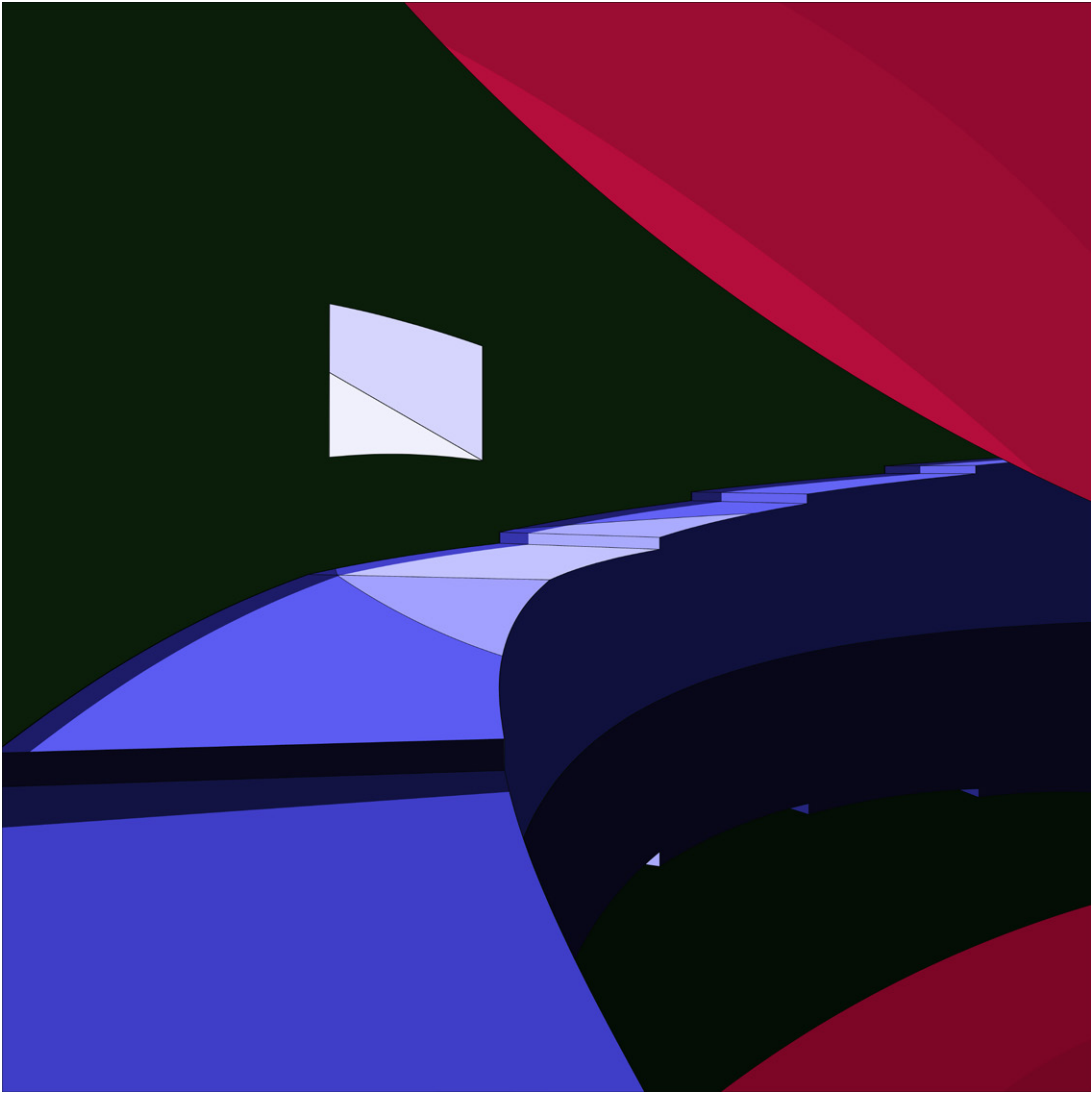

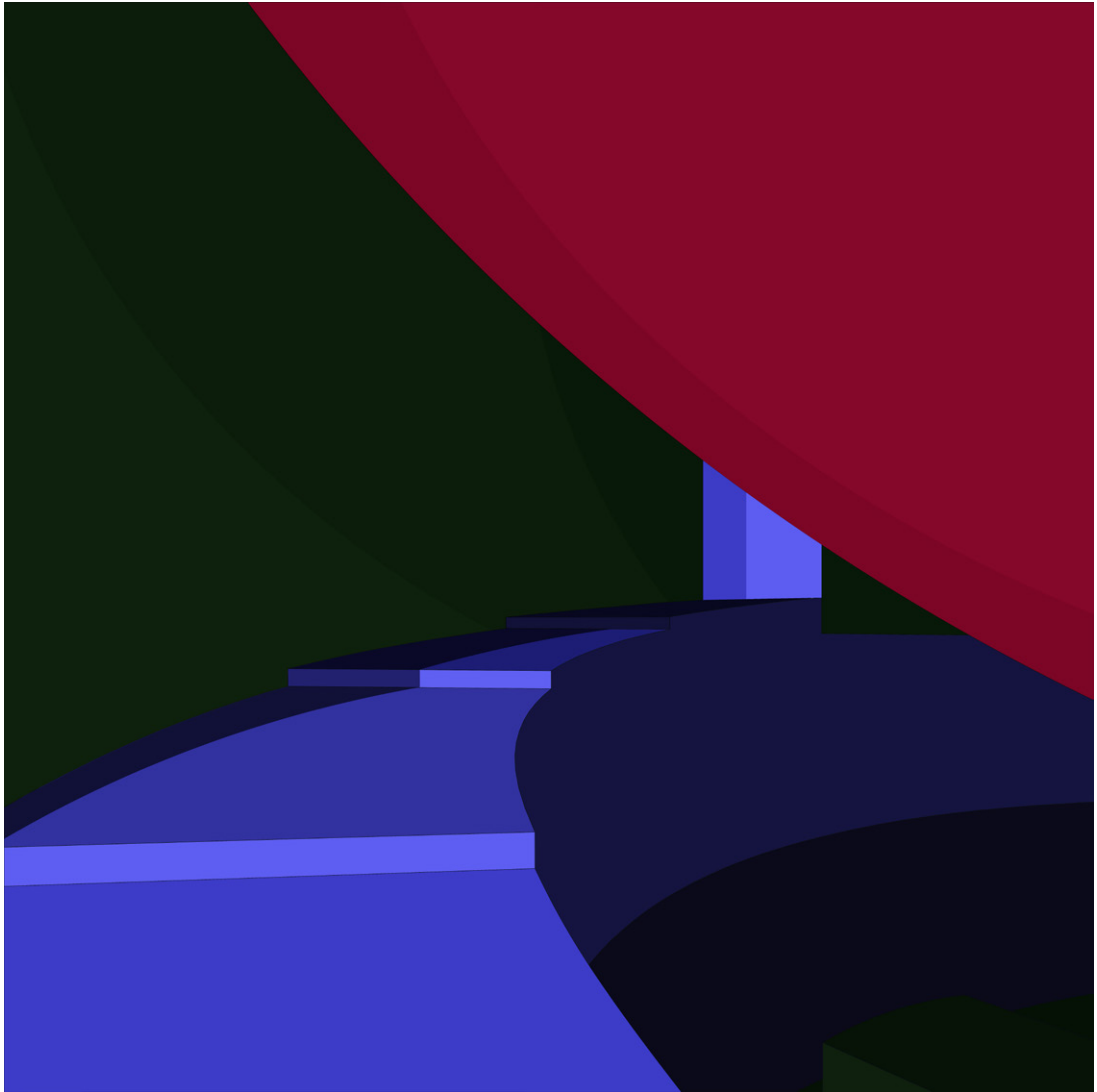

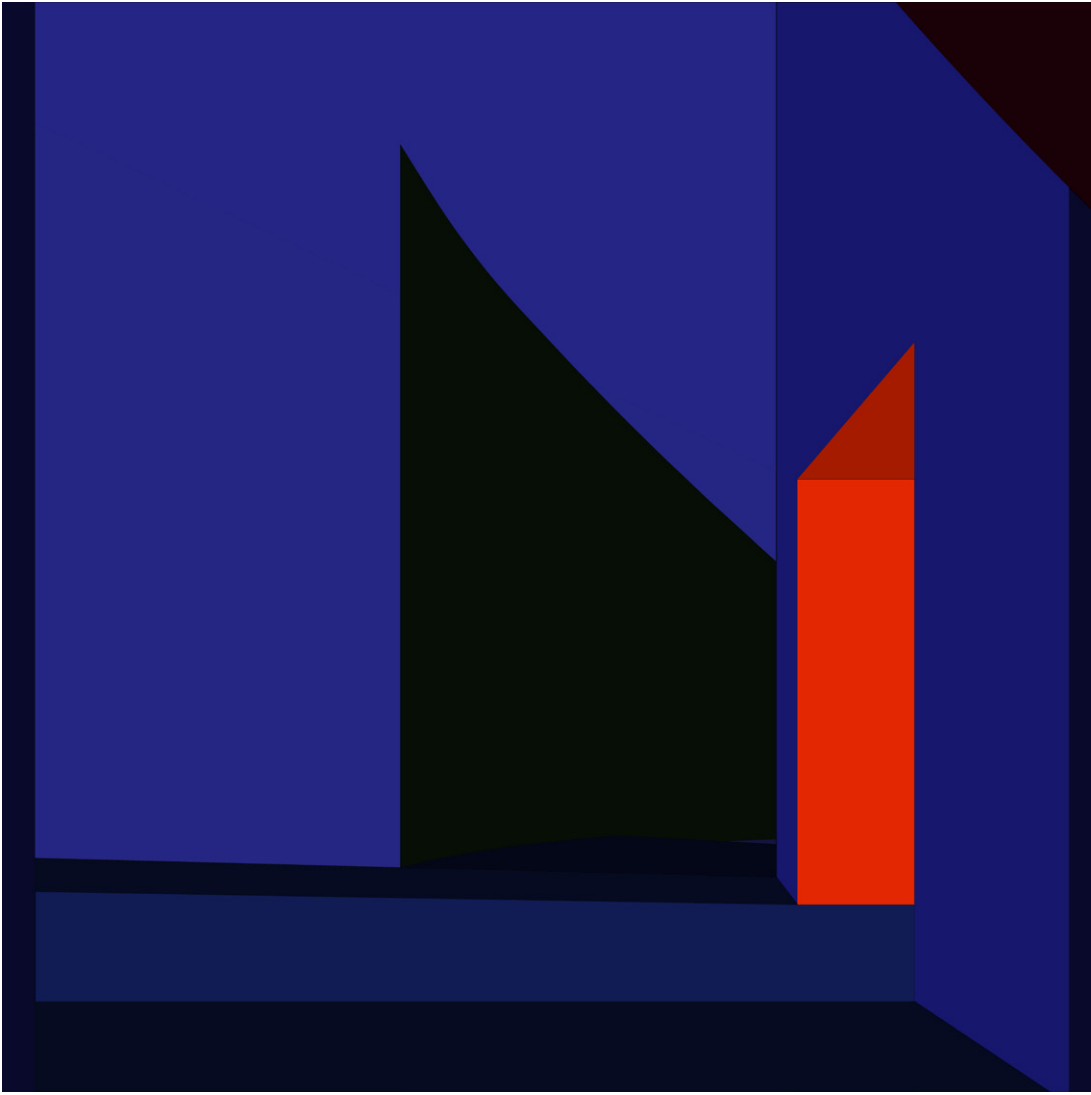

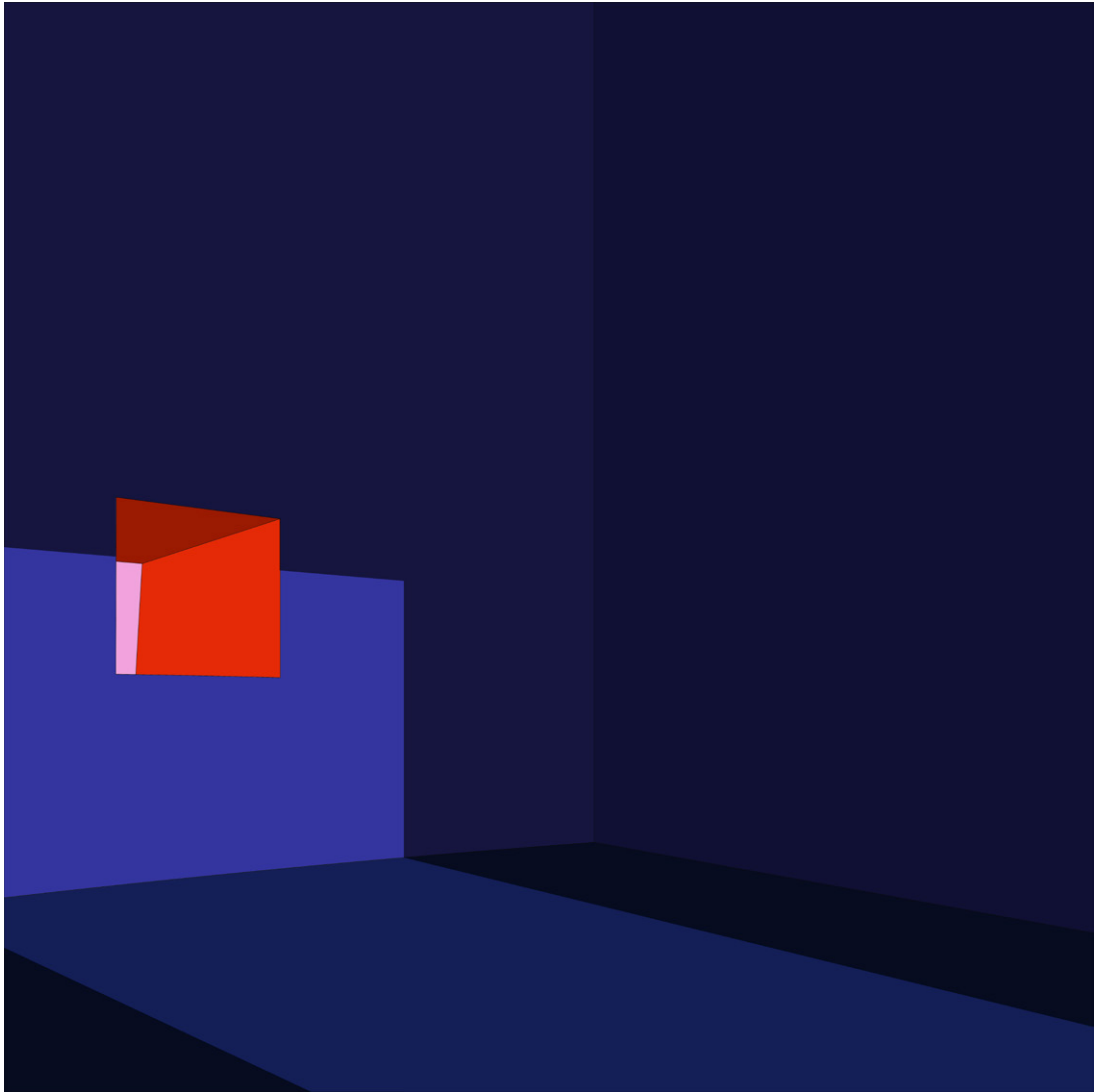

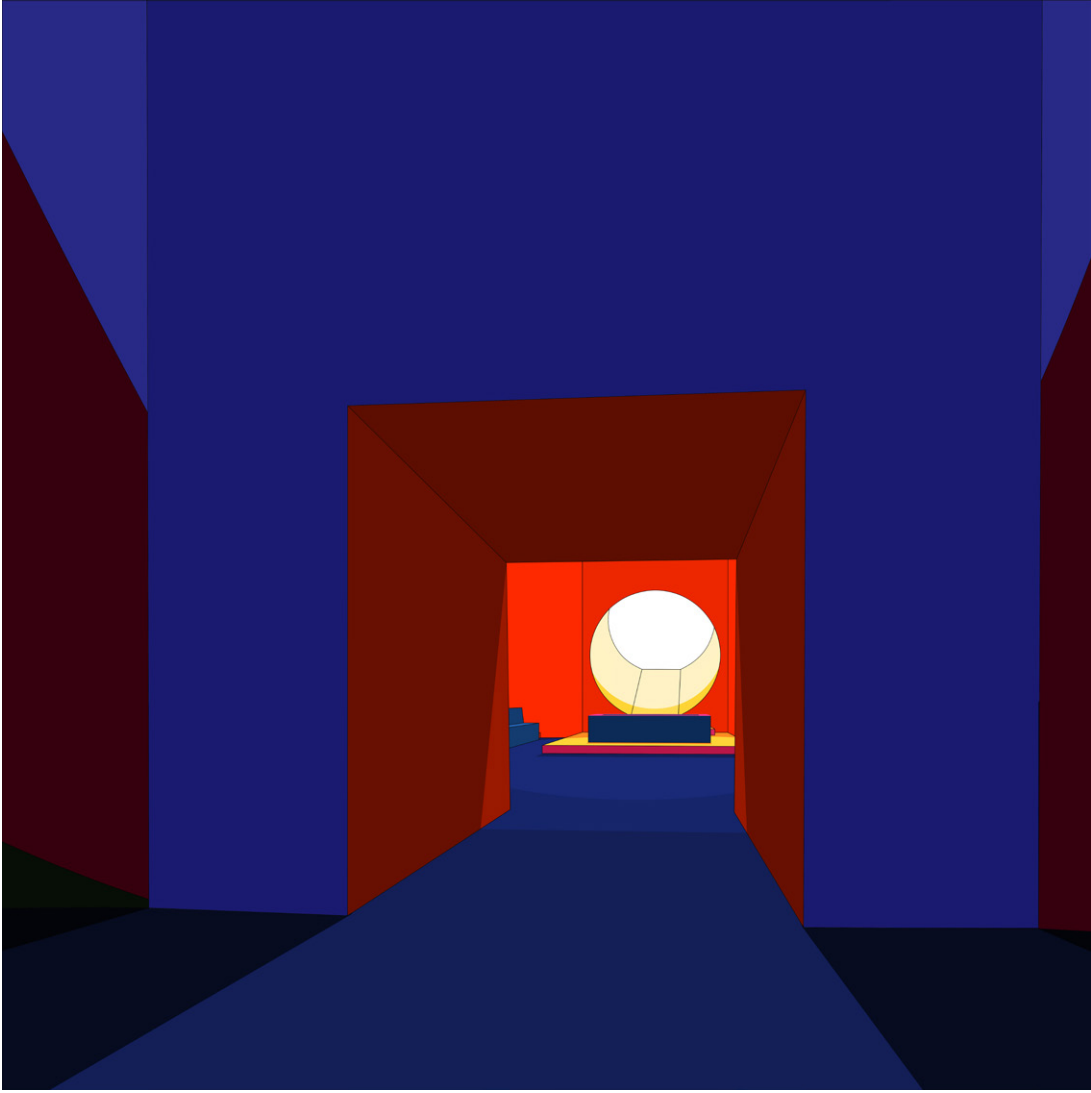

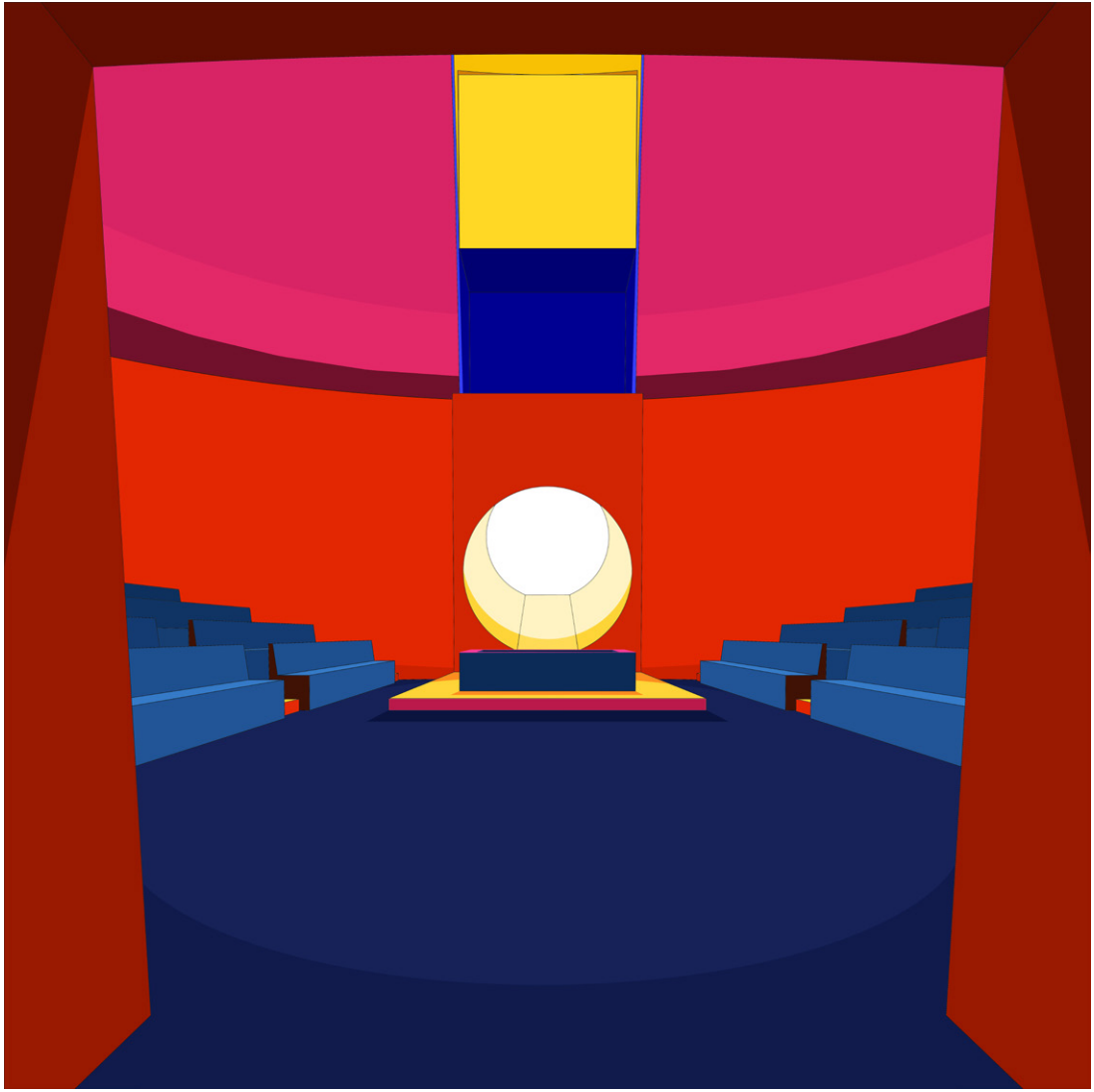

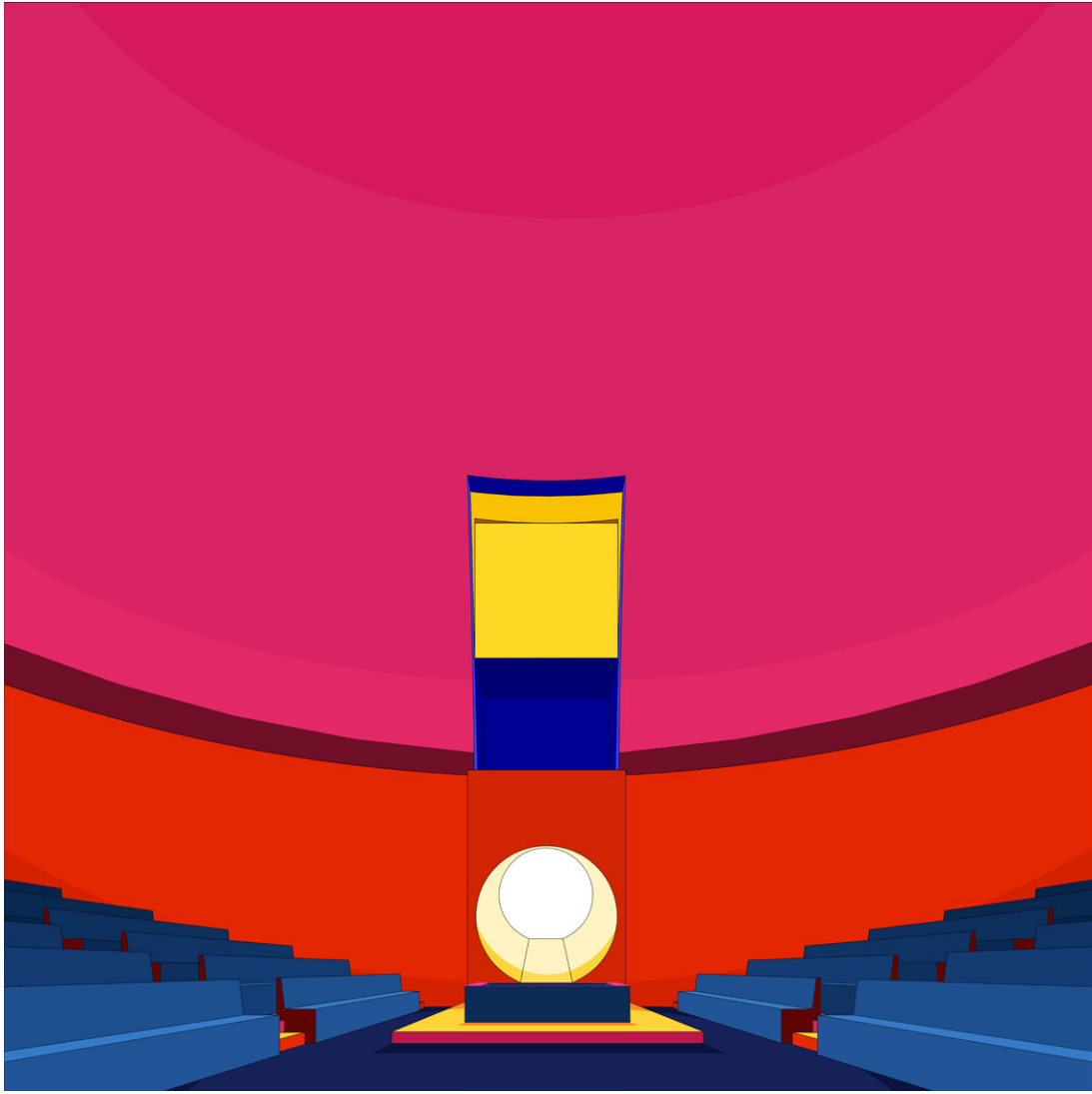

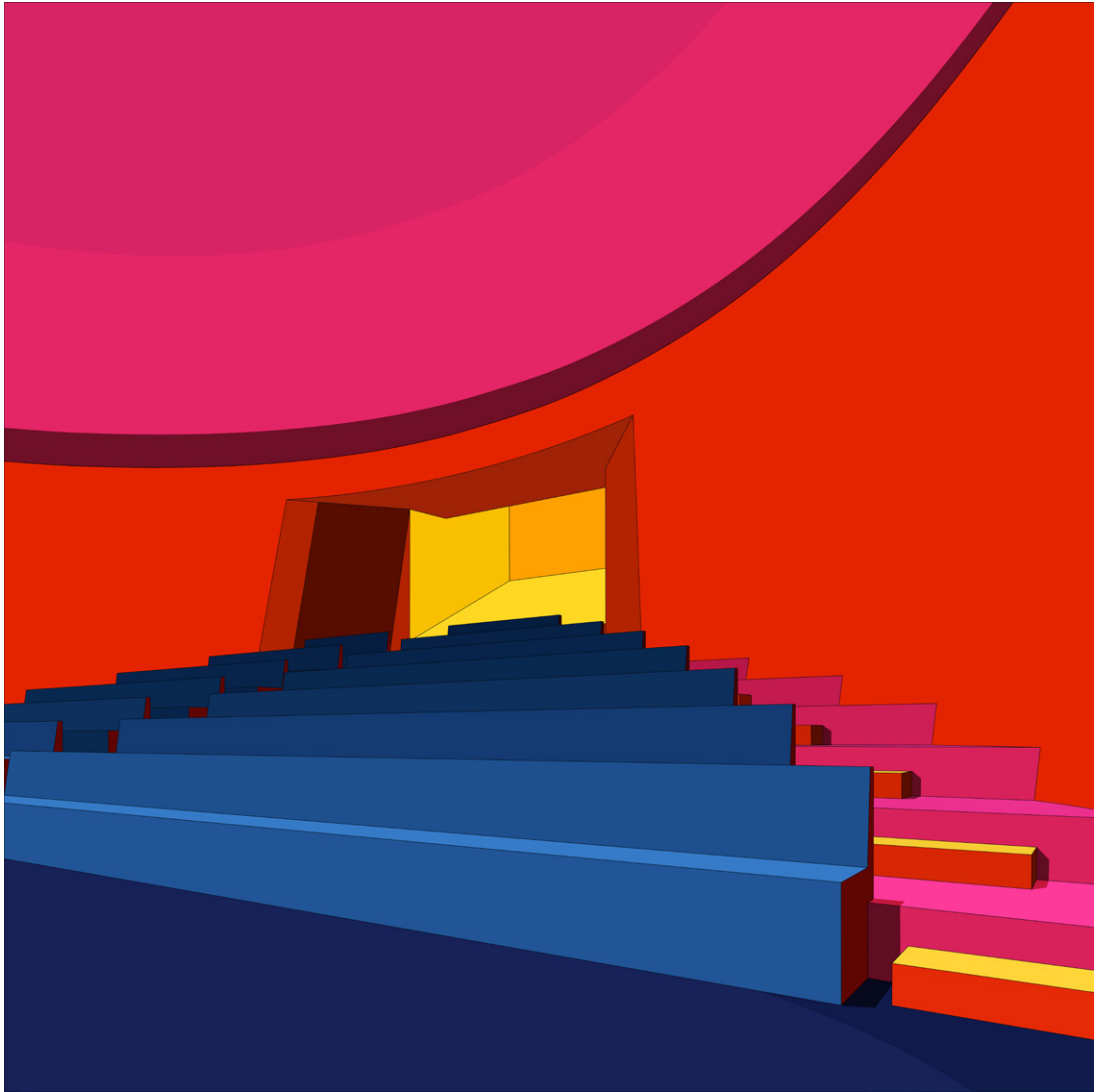

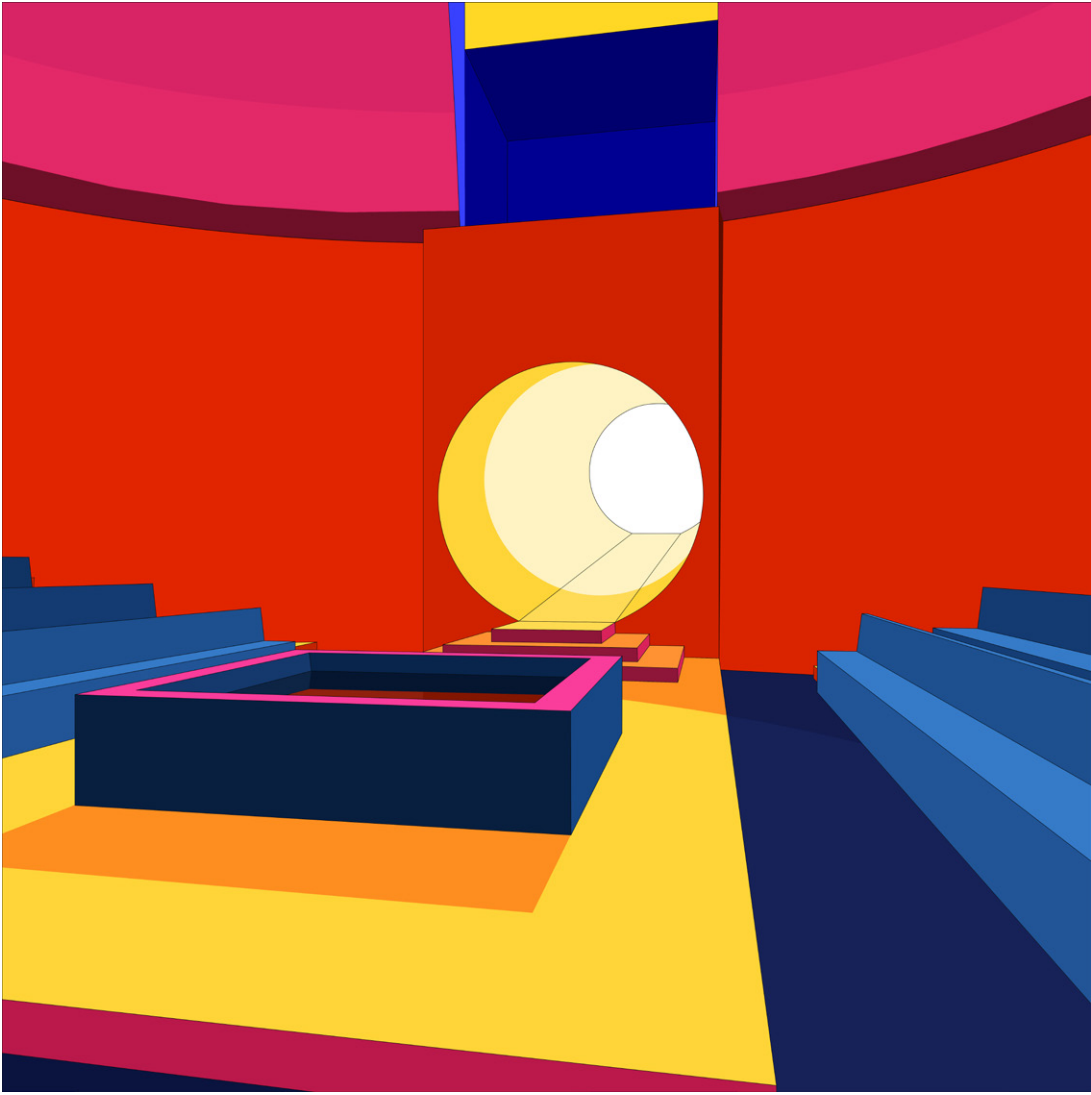





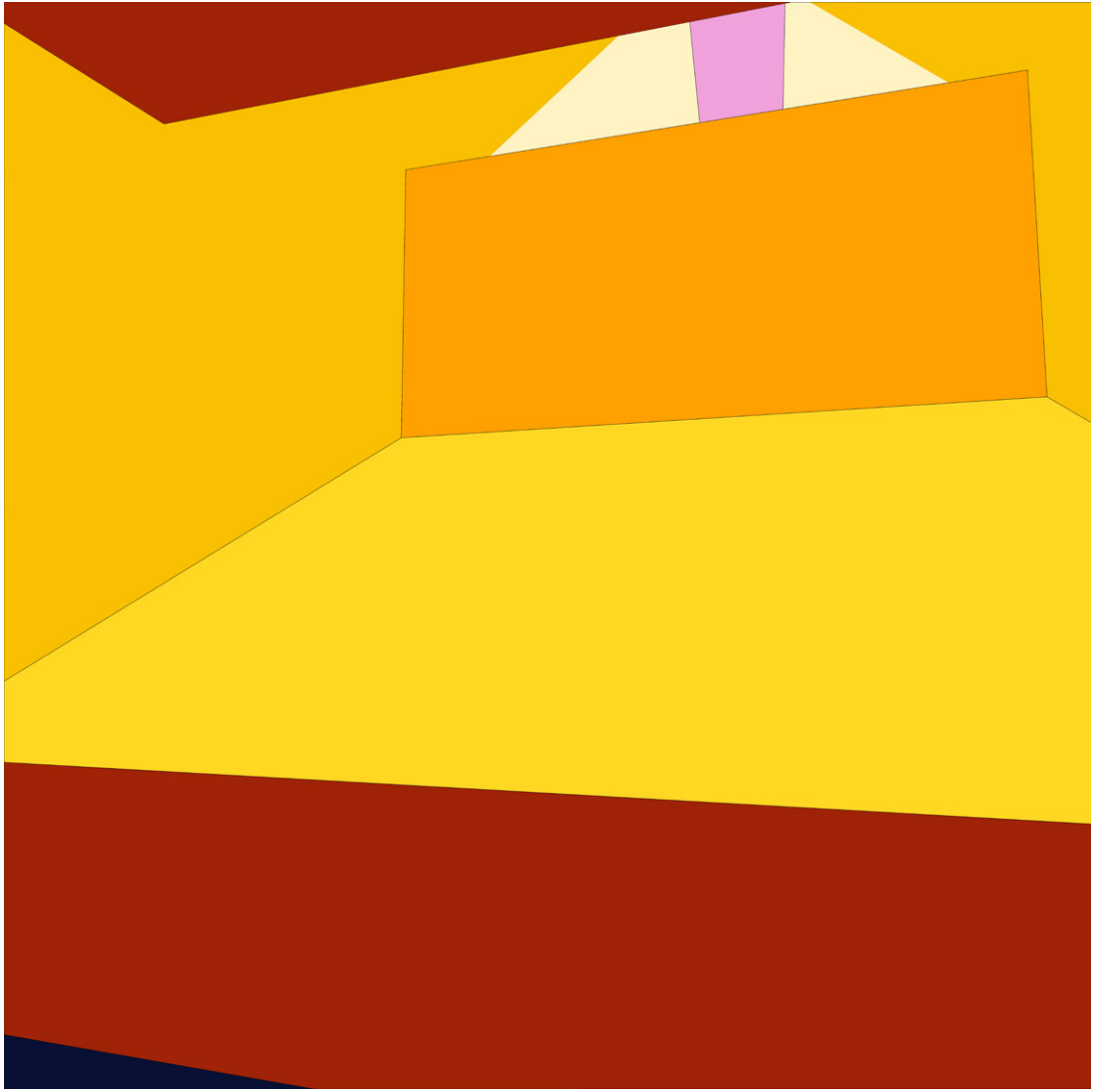

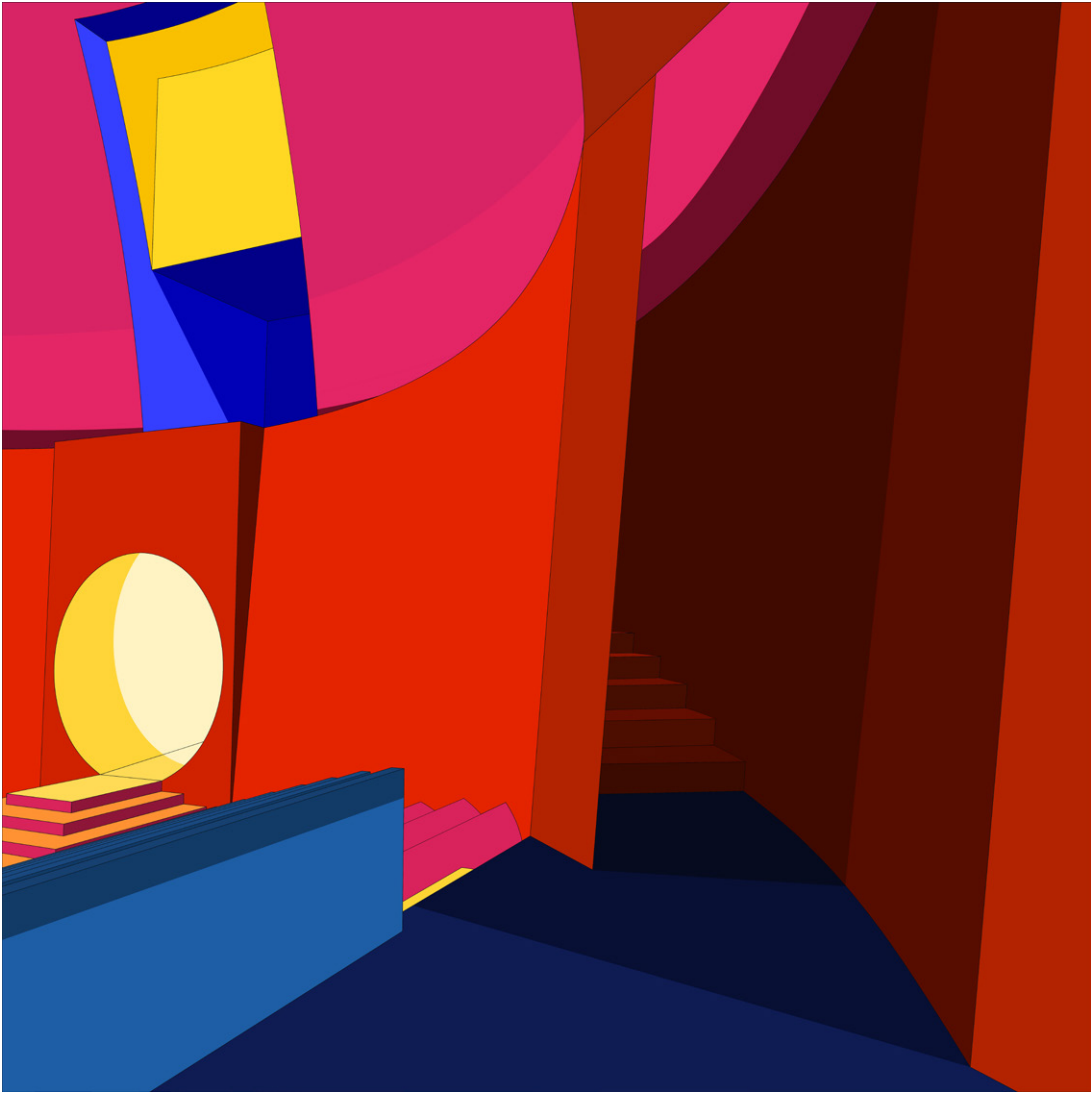

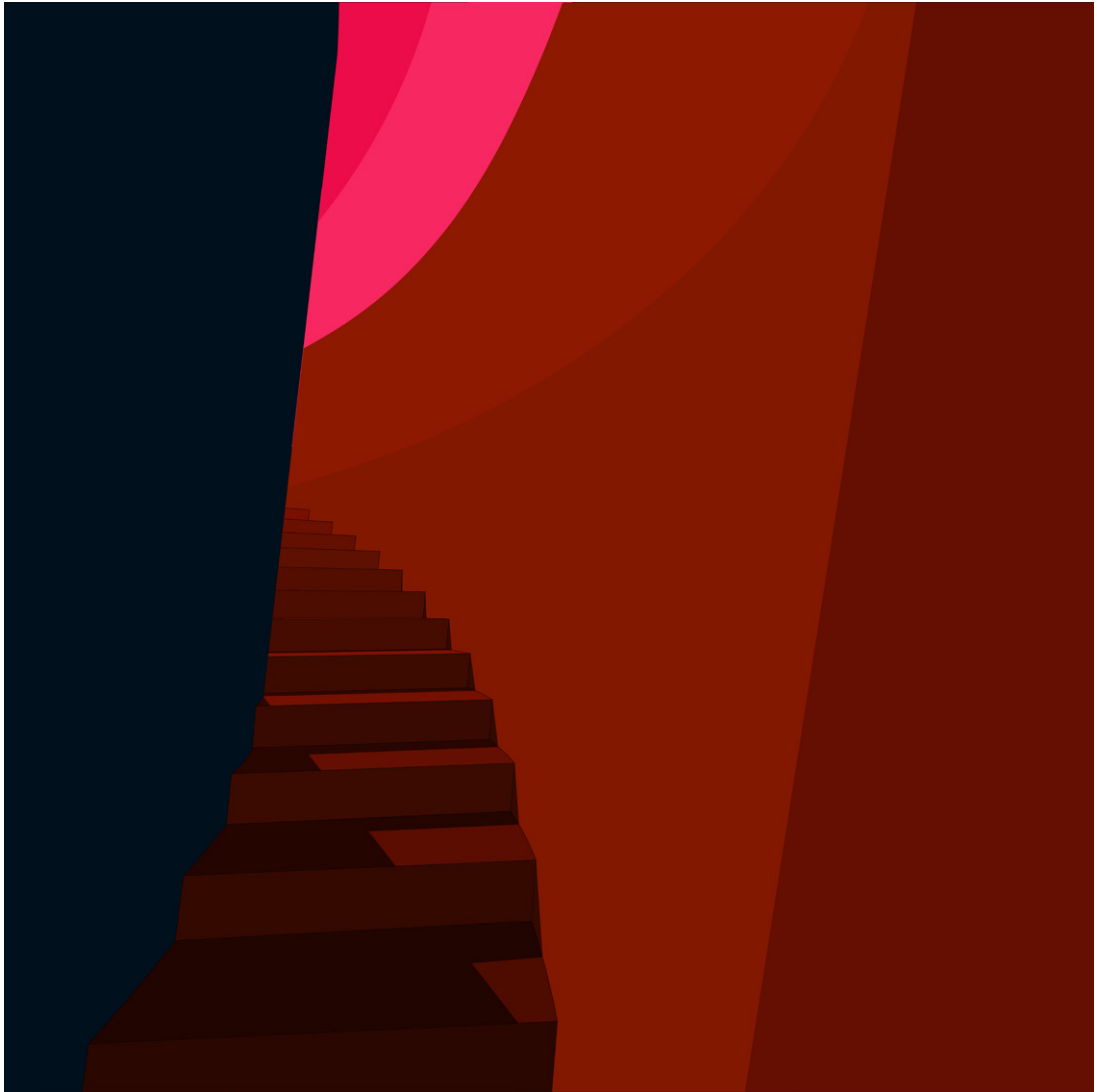

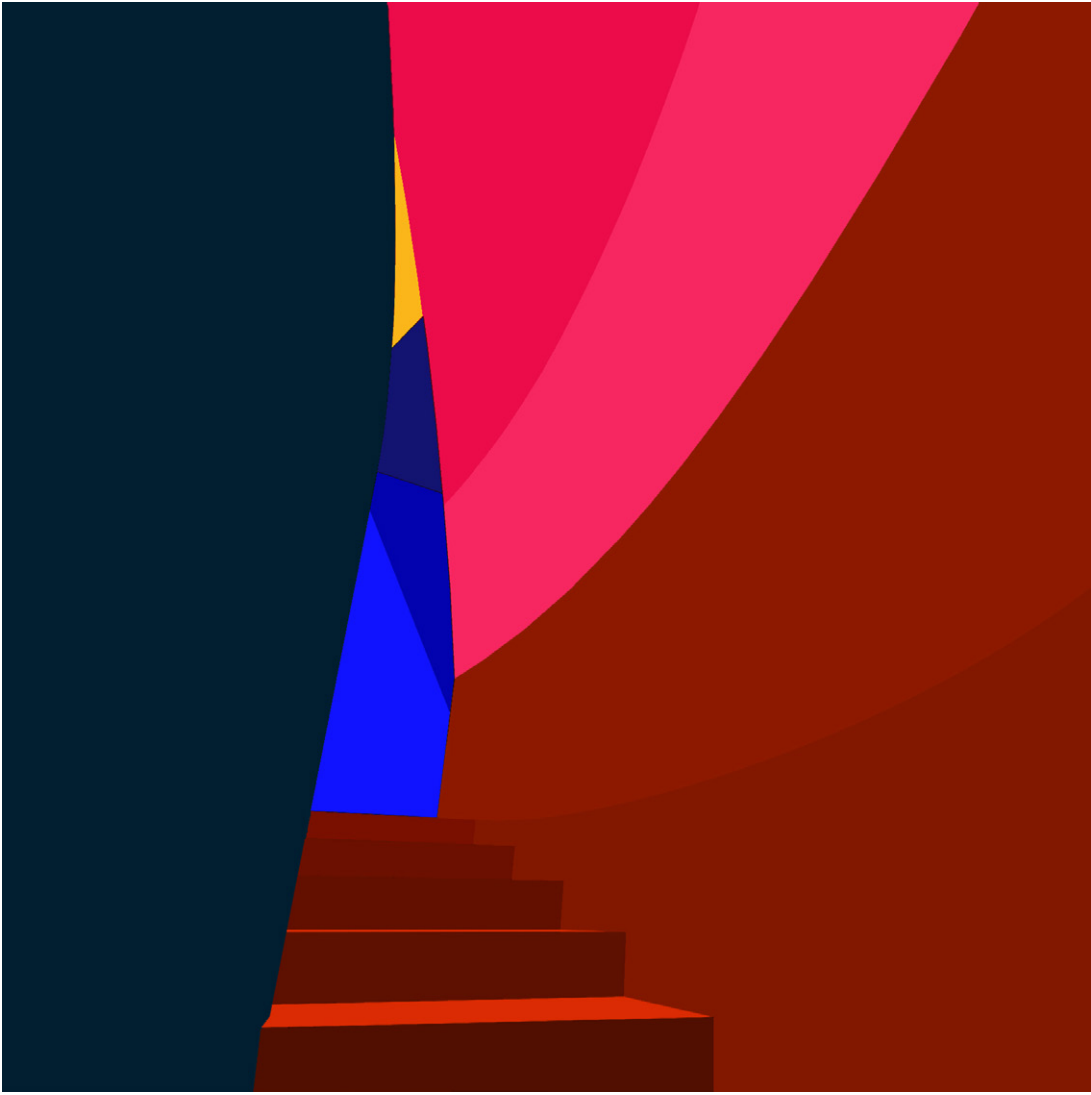







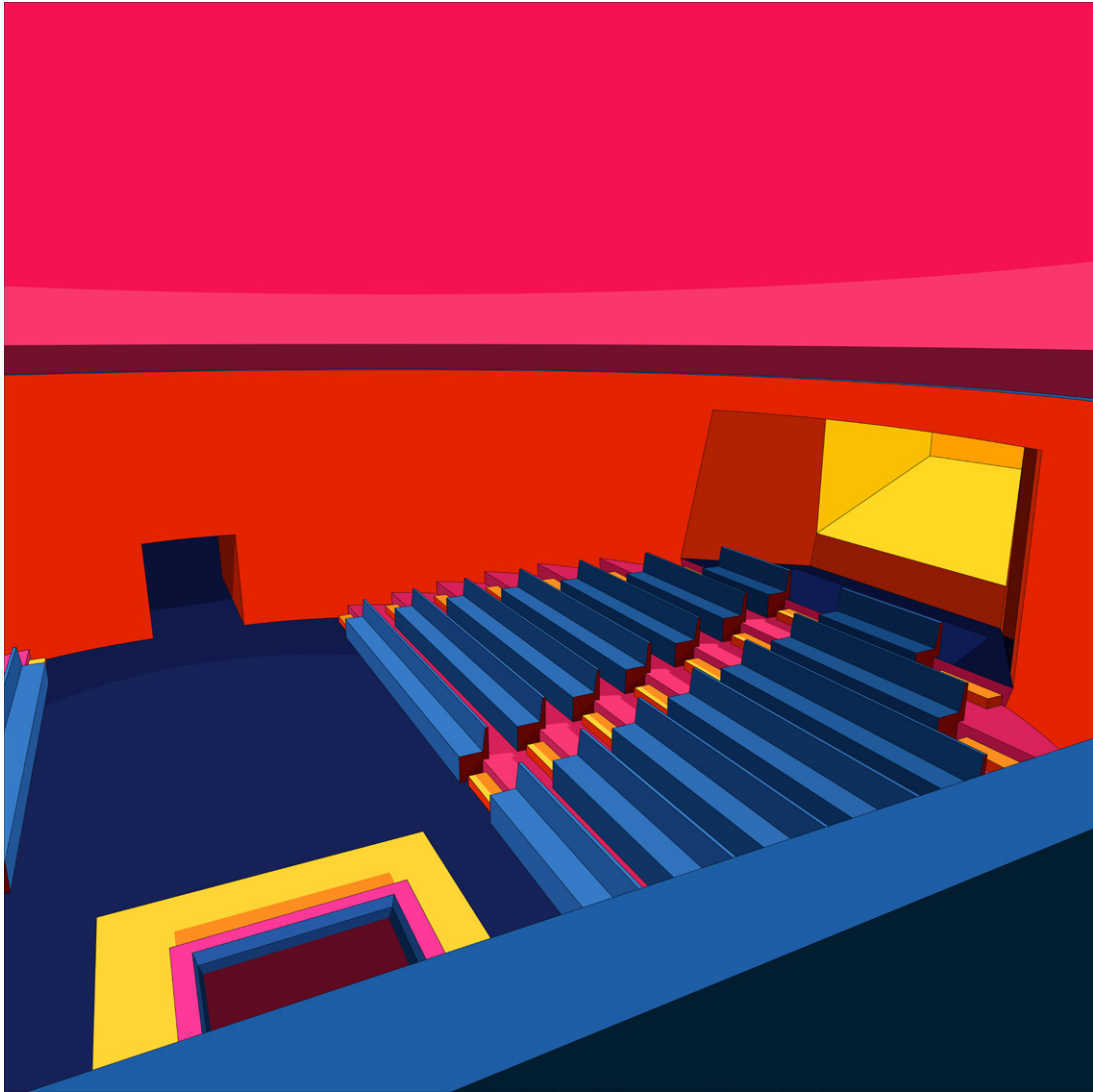



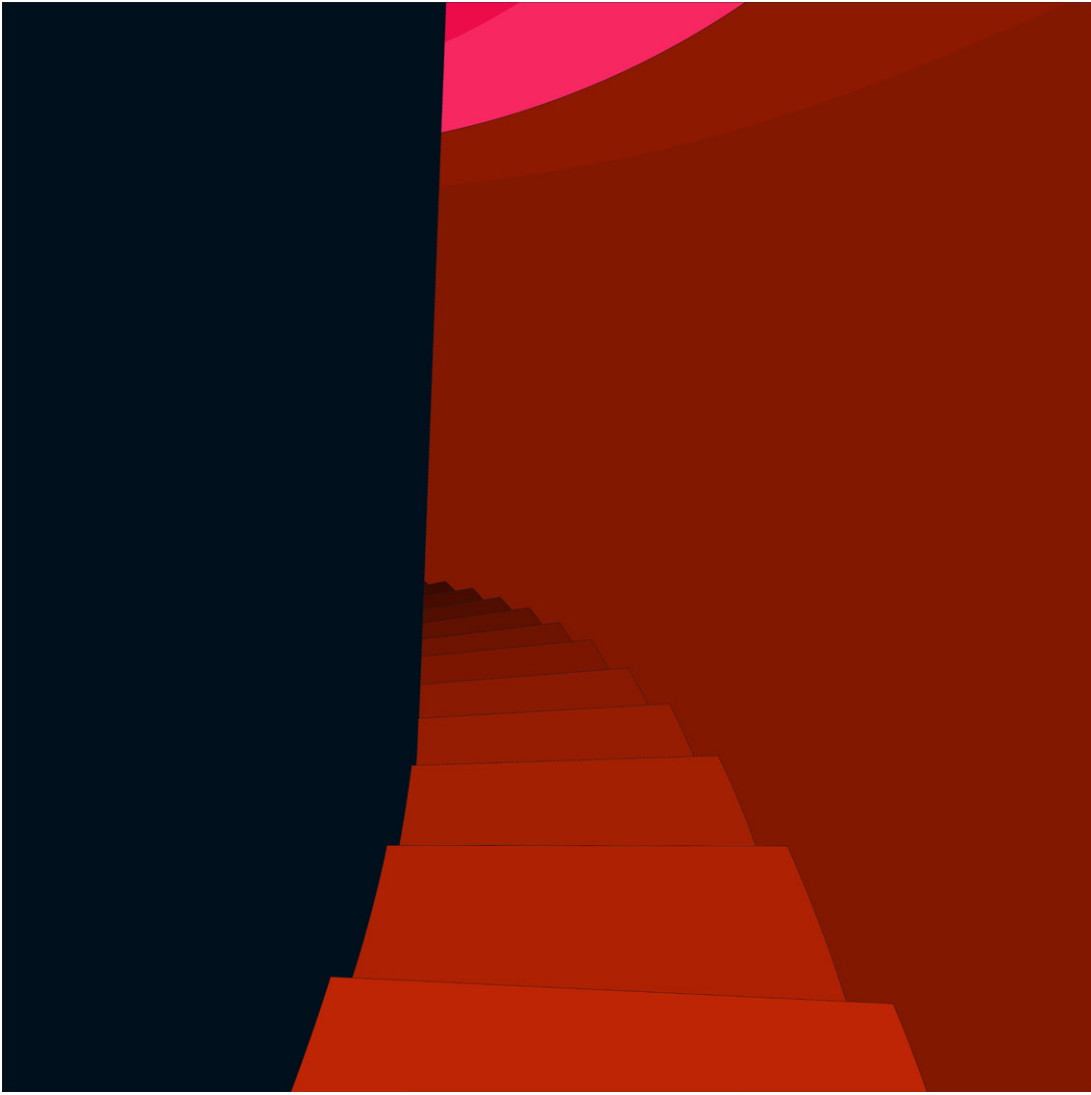



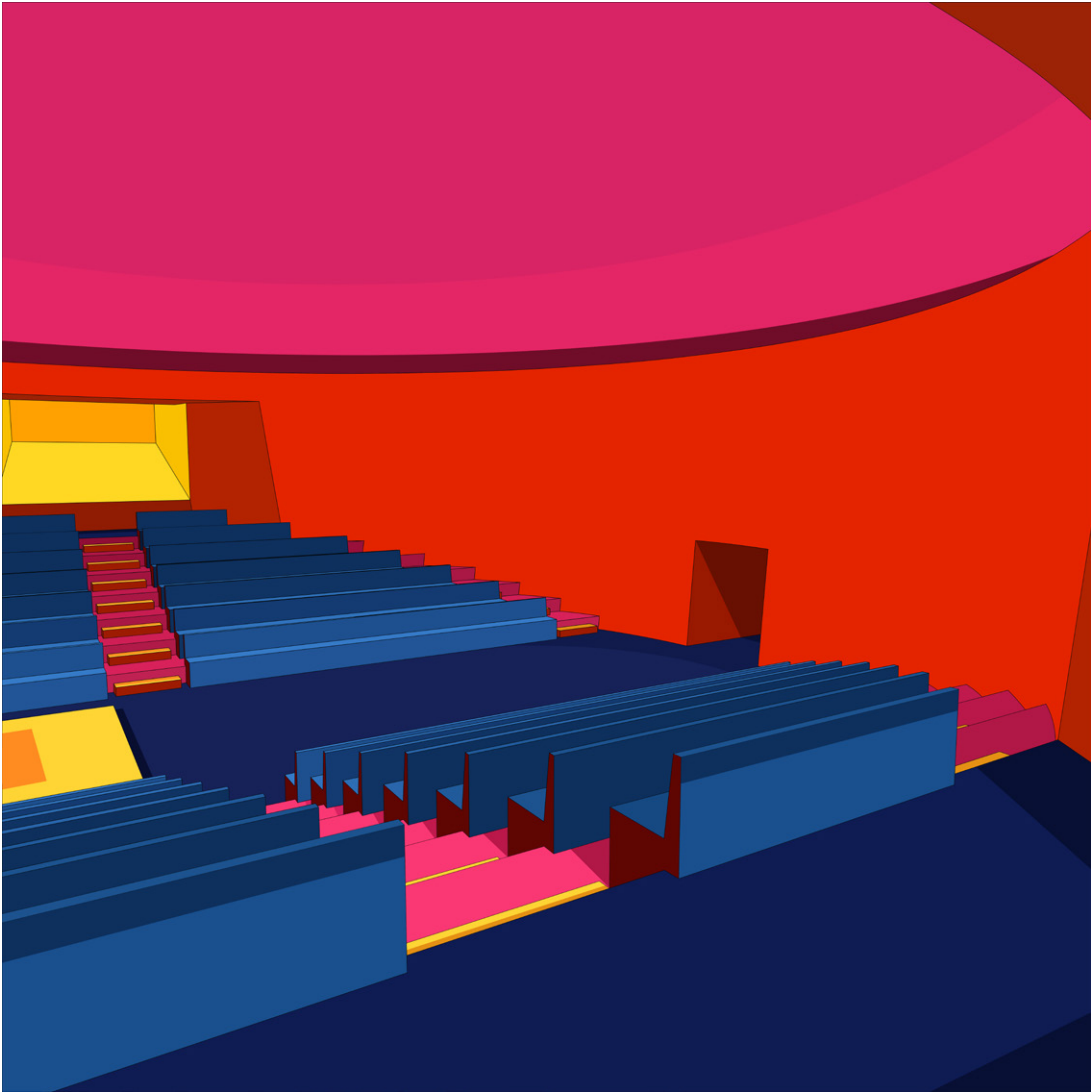

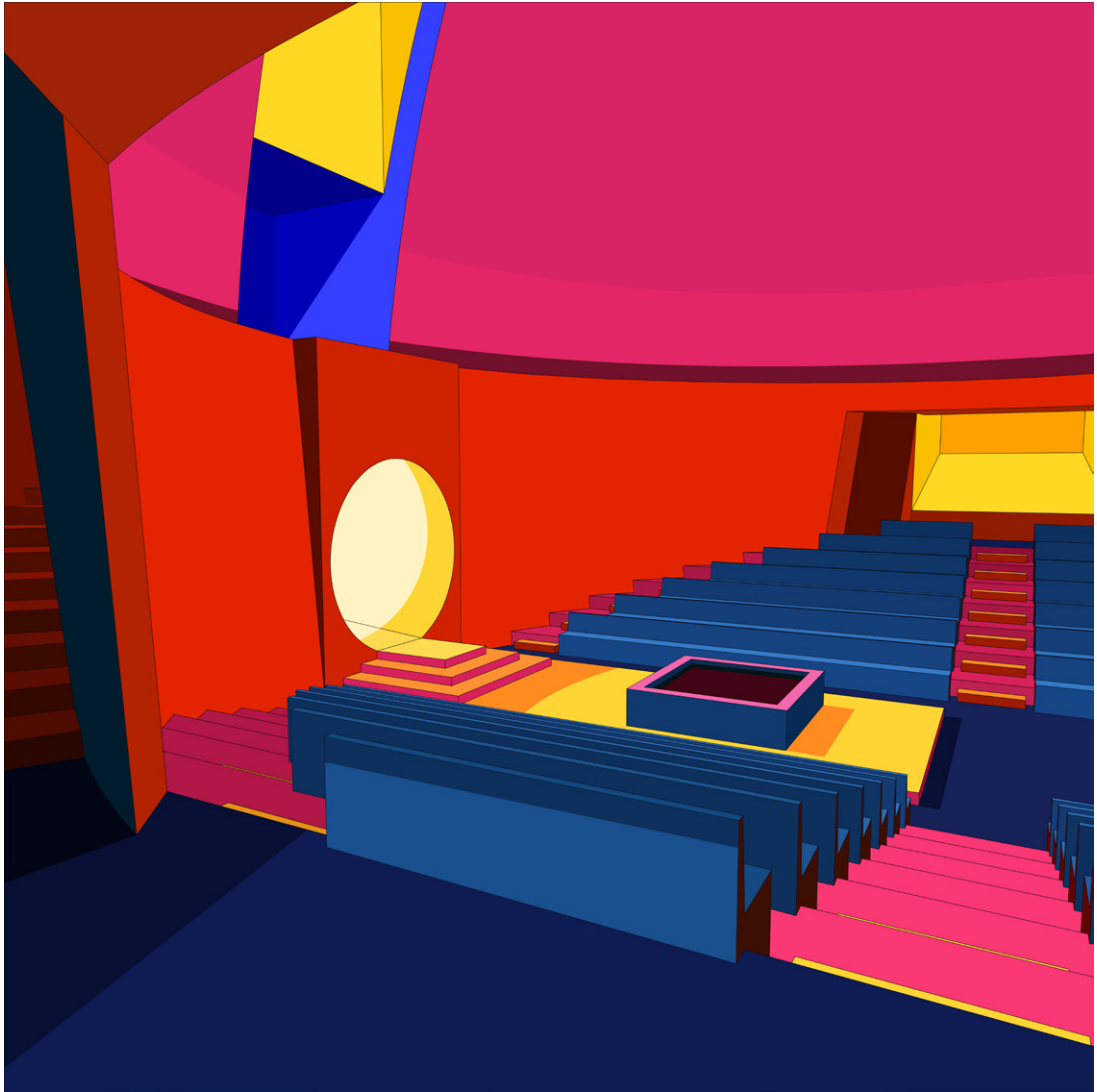

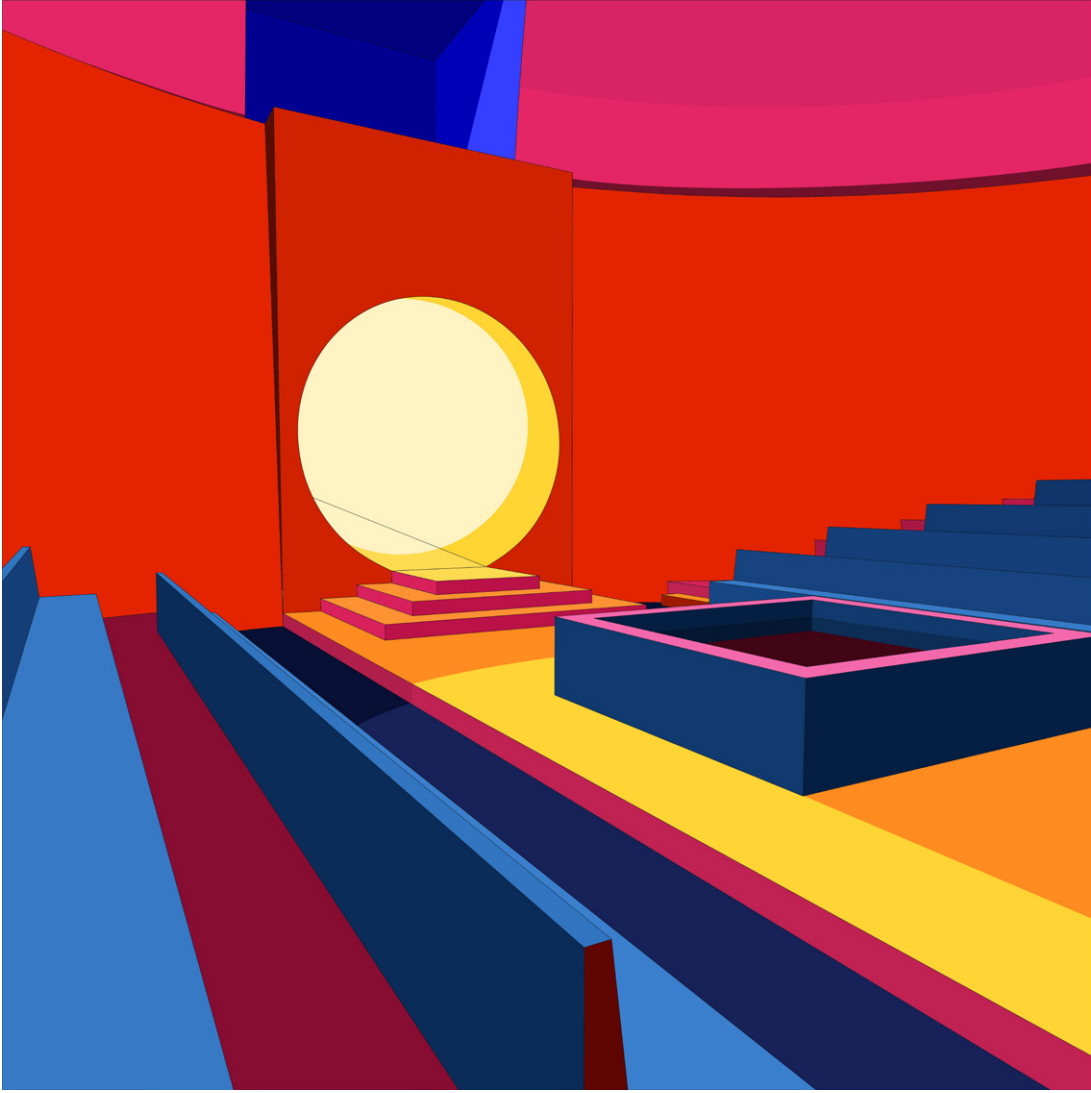

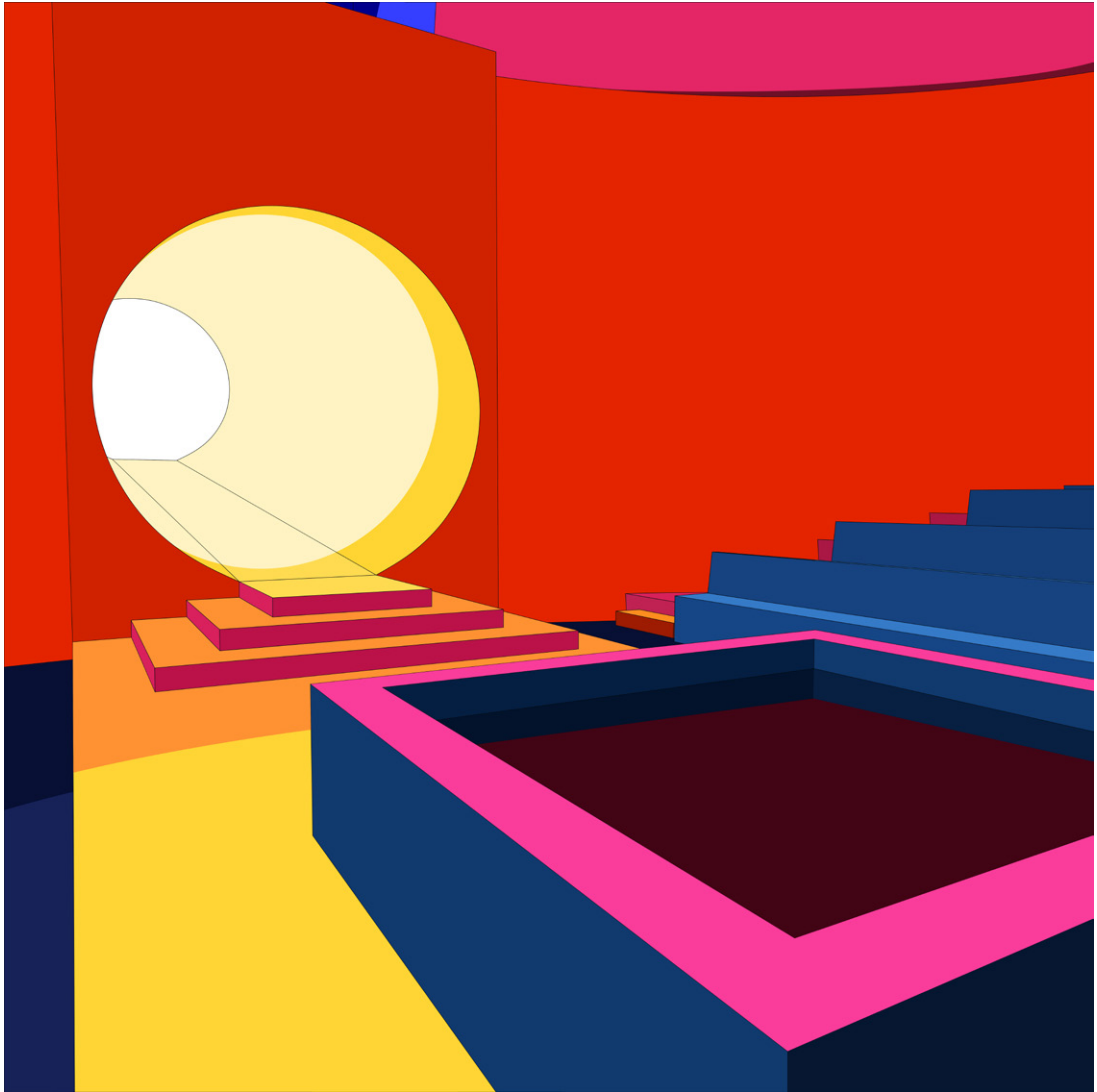

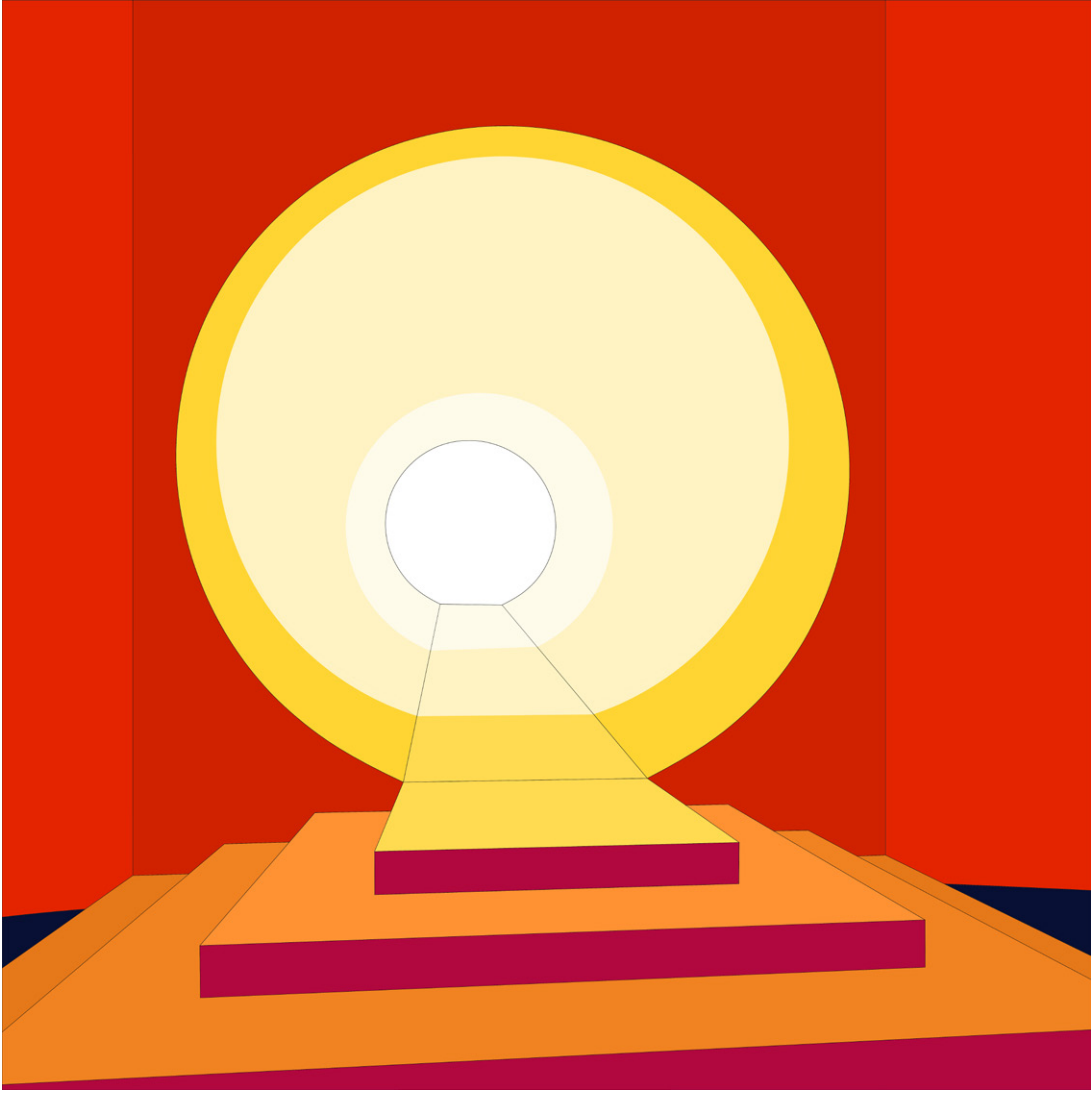

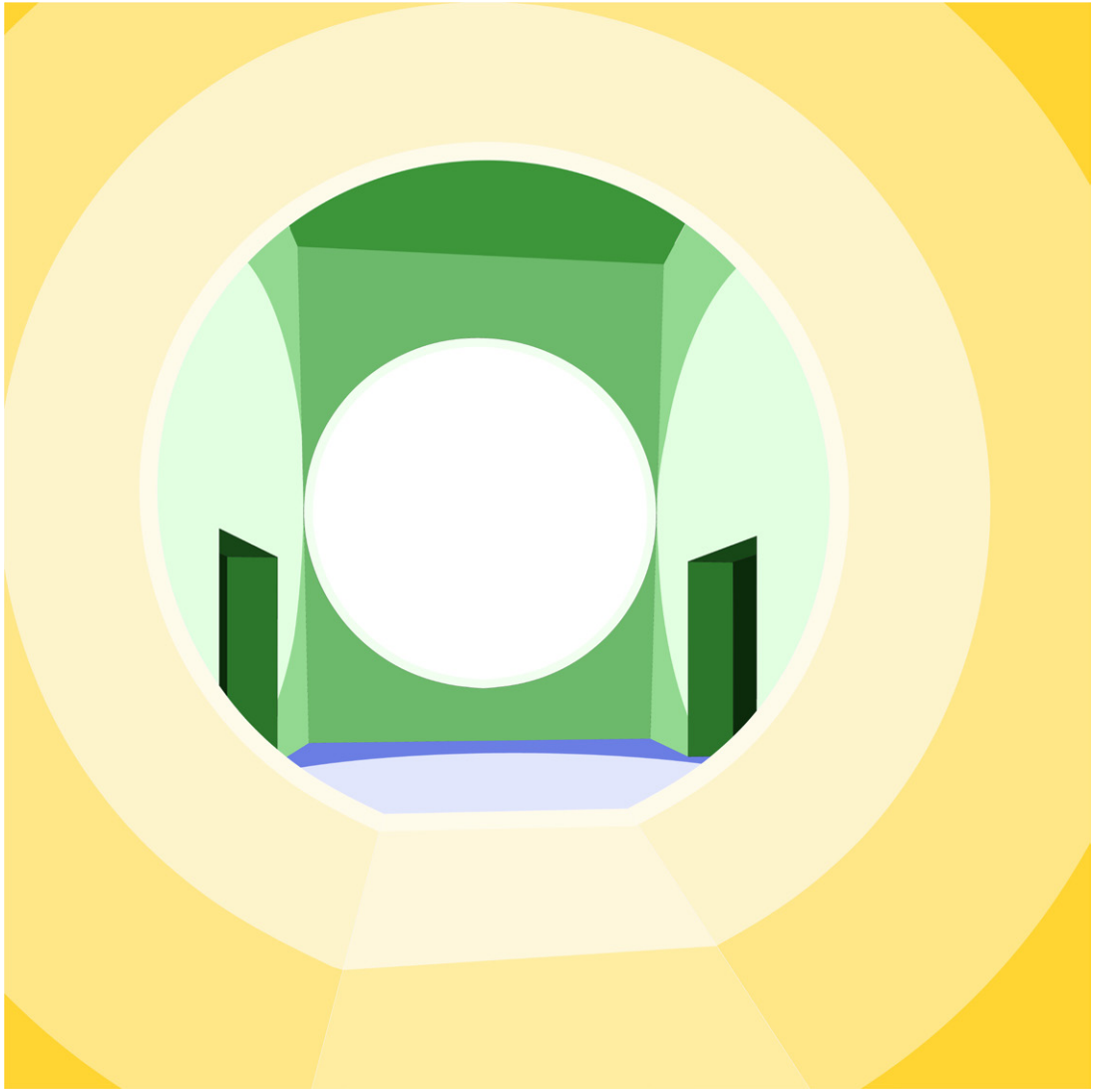

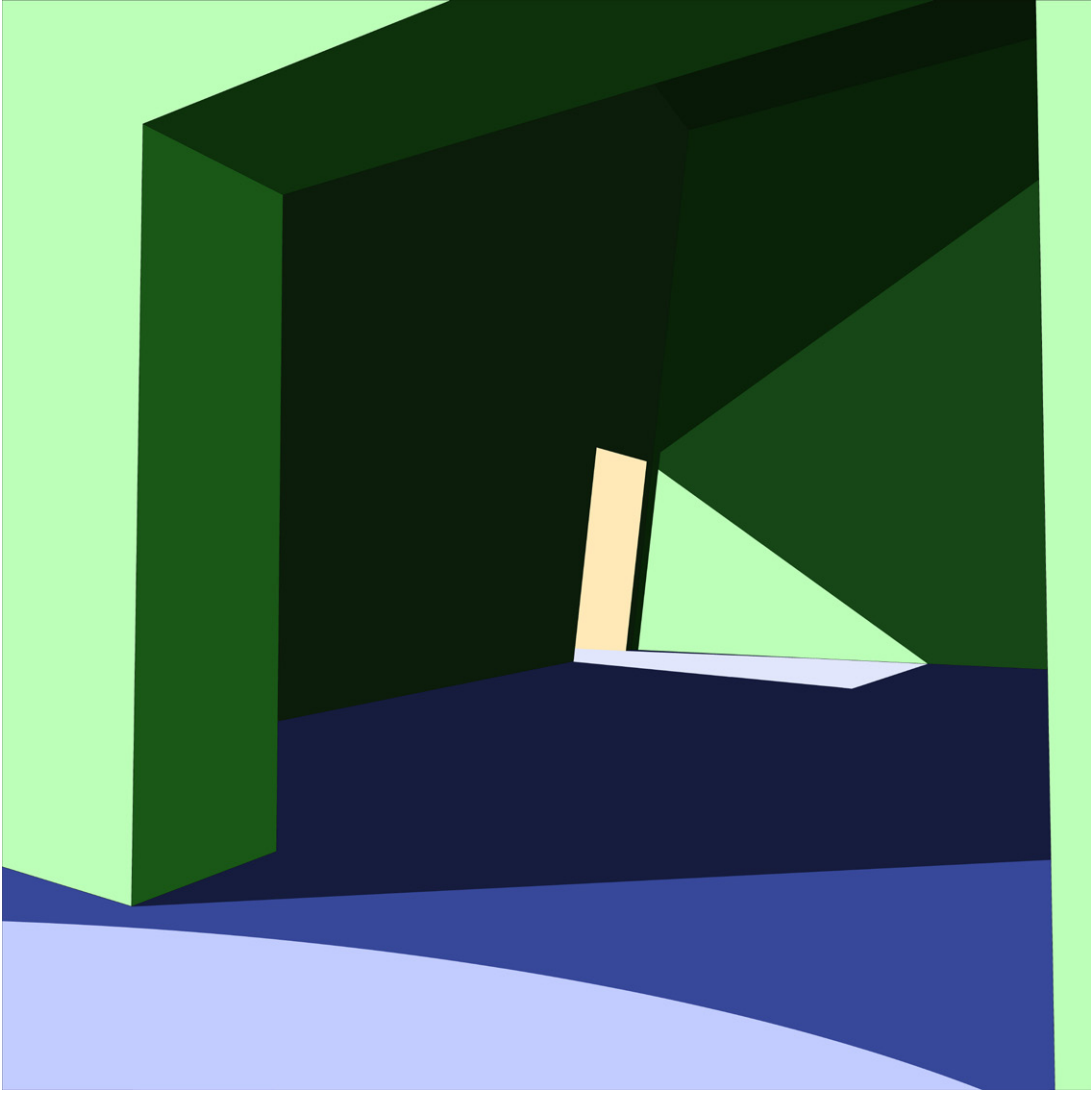

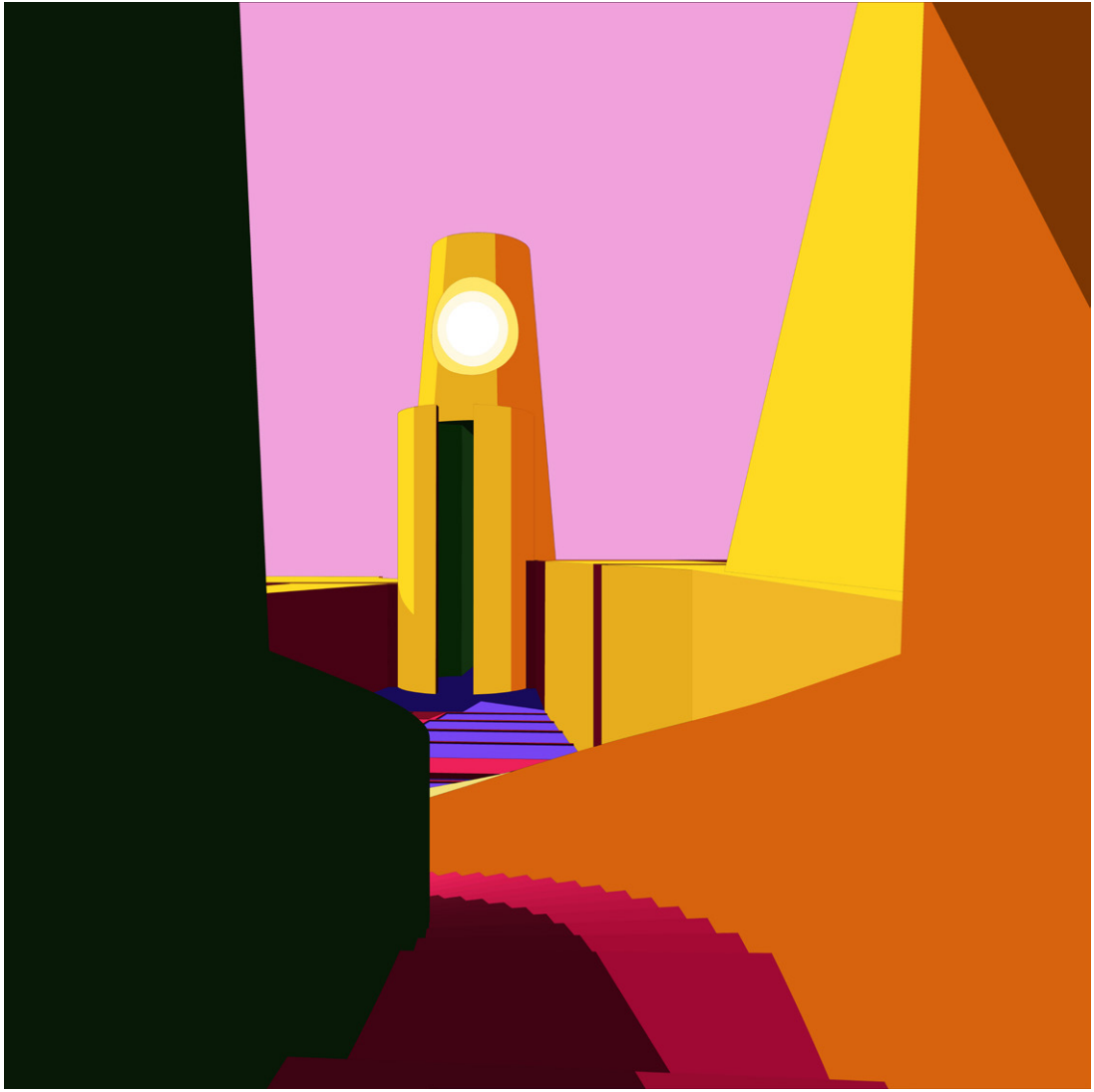

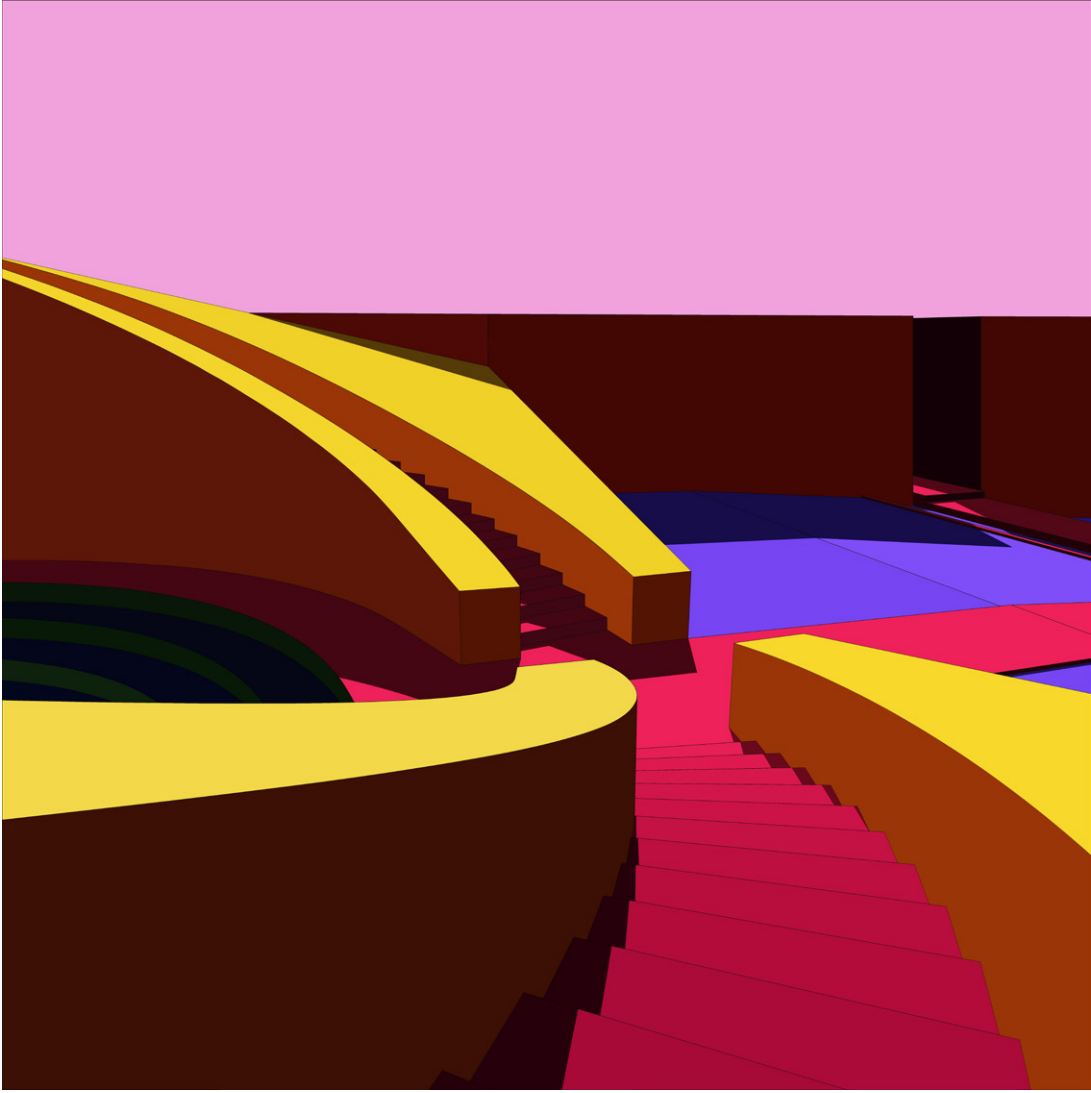

ITERATION 6. COLOR

walk (2)

layers of complexity (space, form, light
and color)



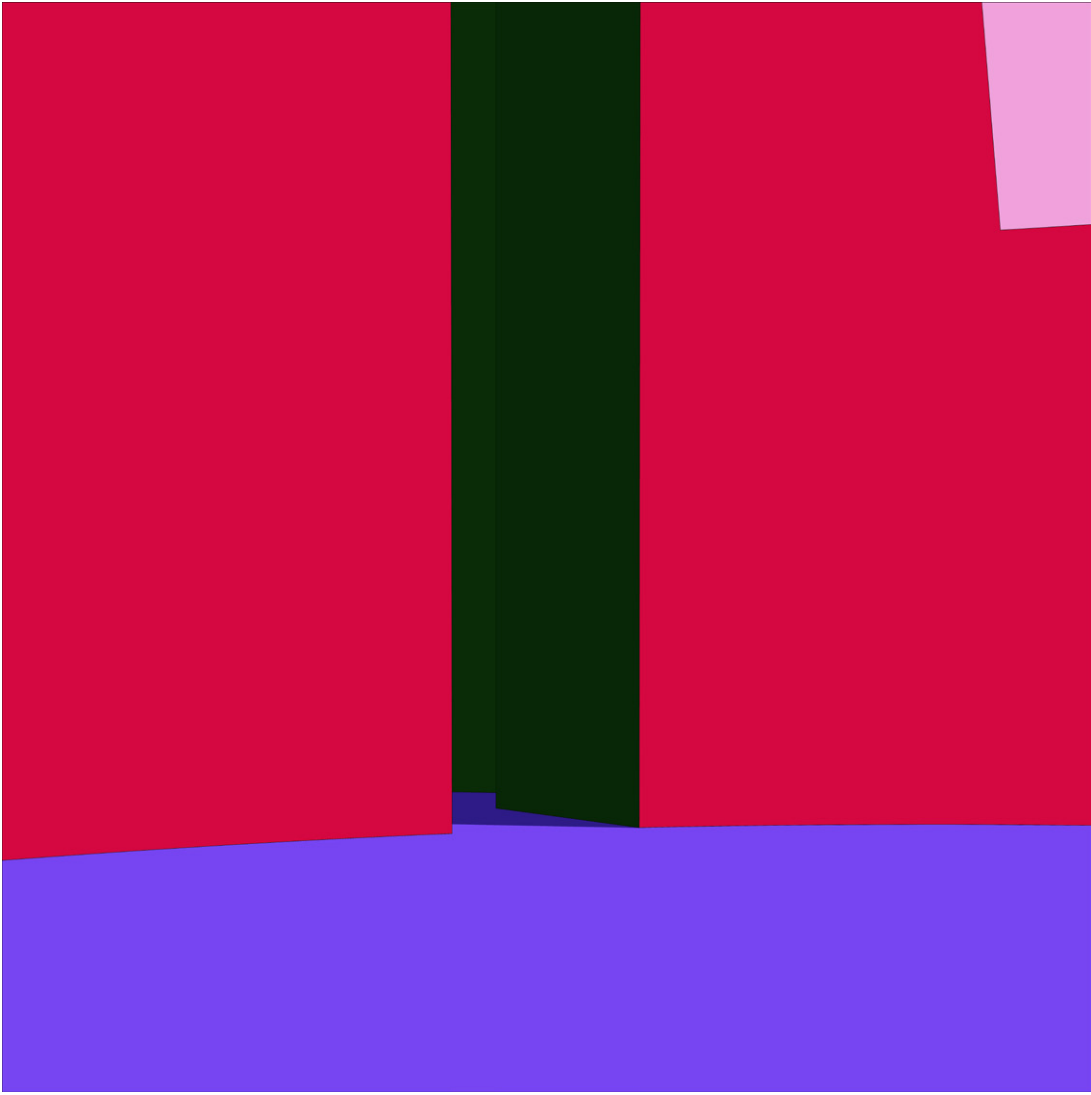



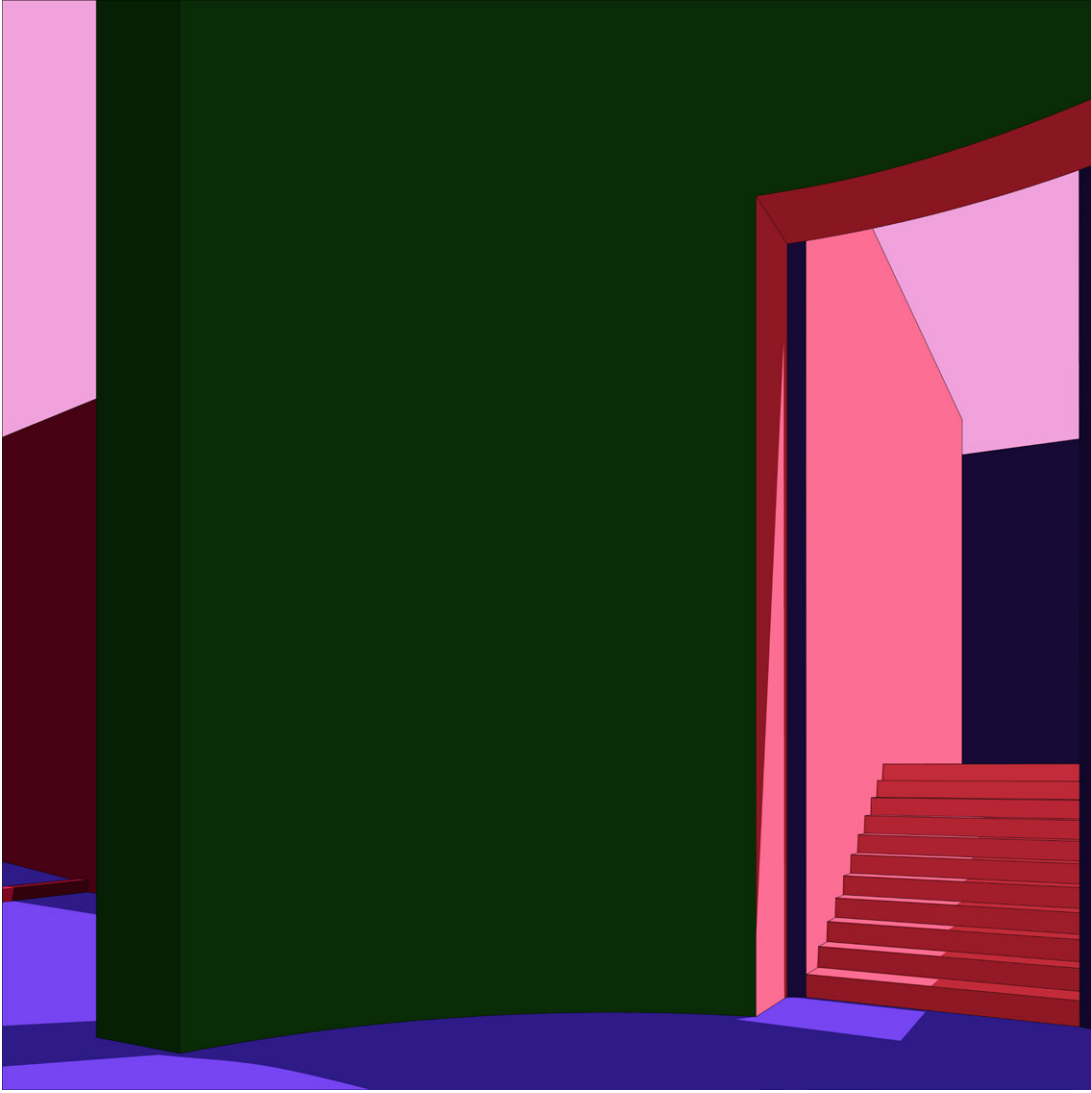

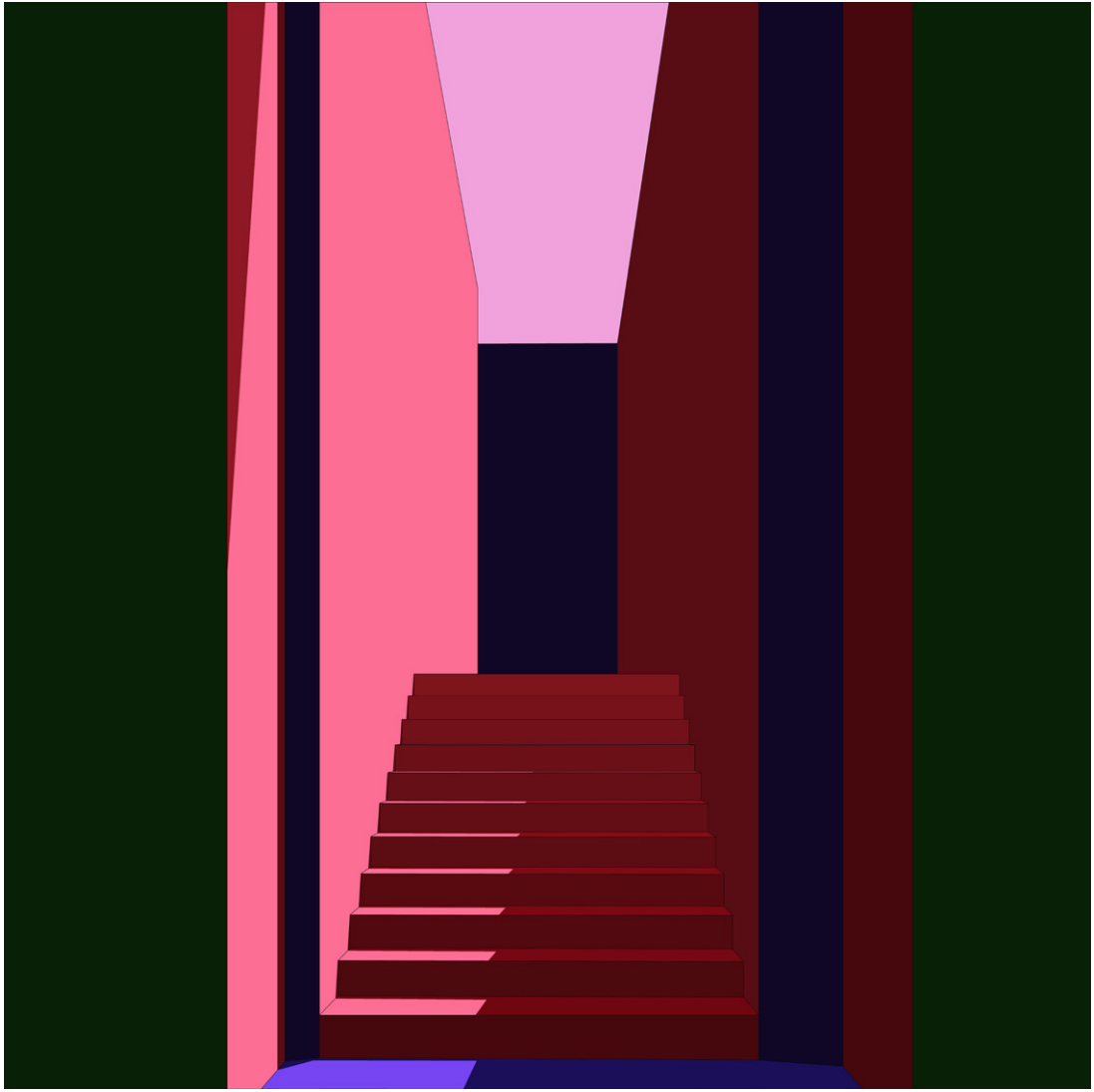

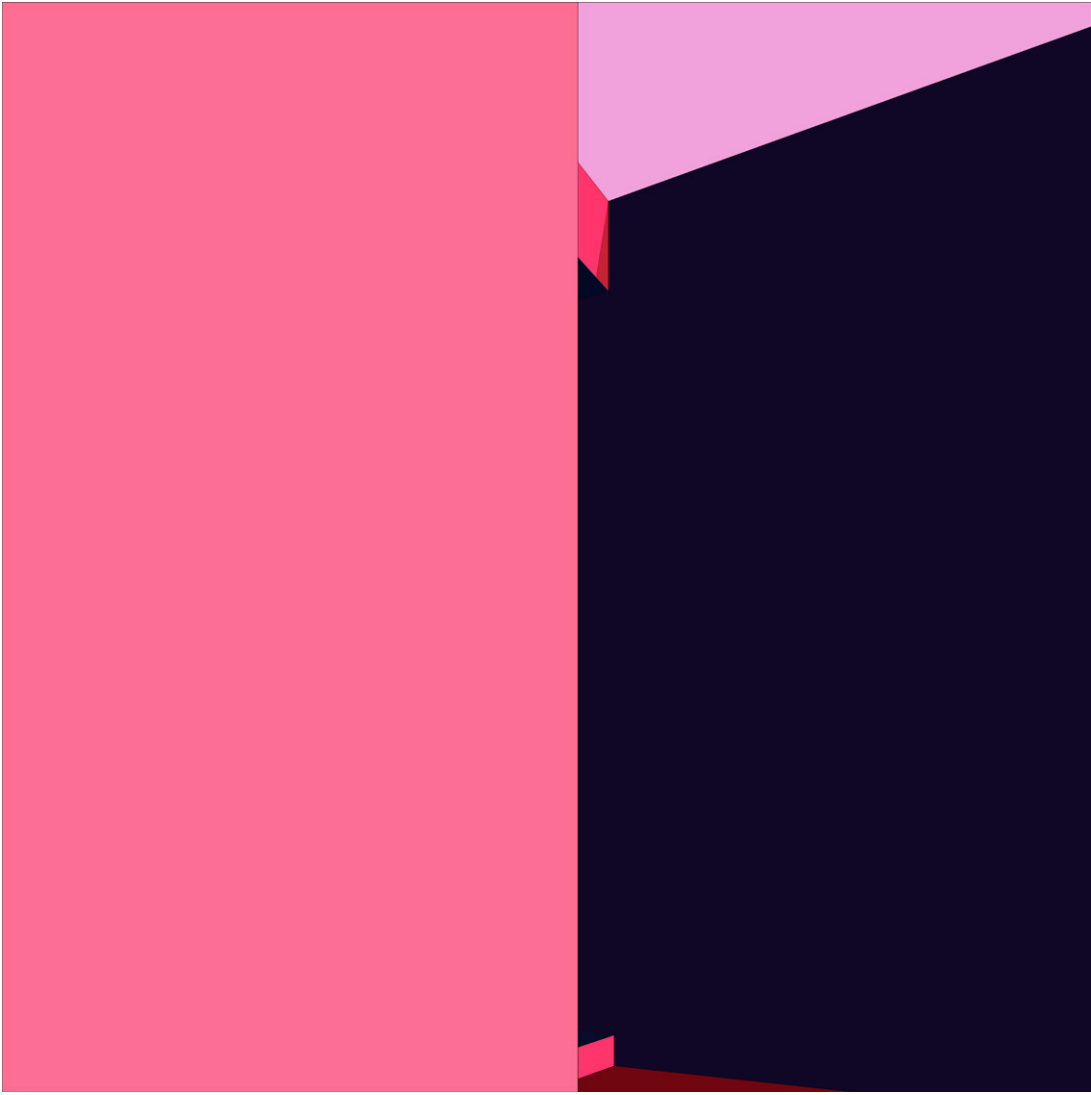

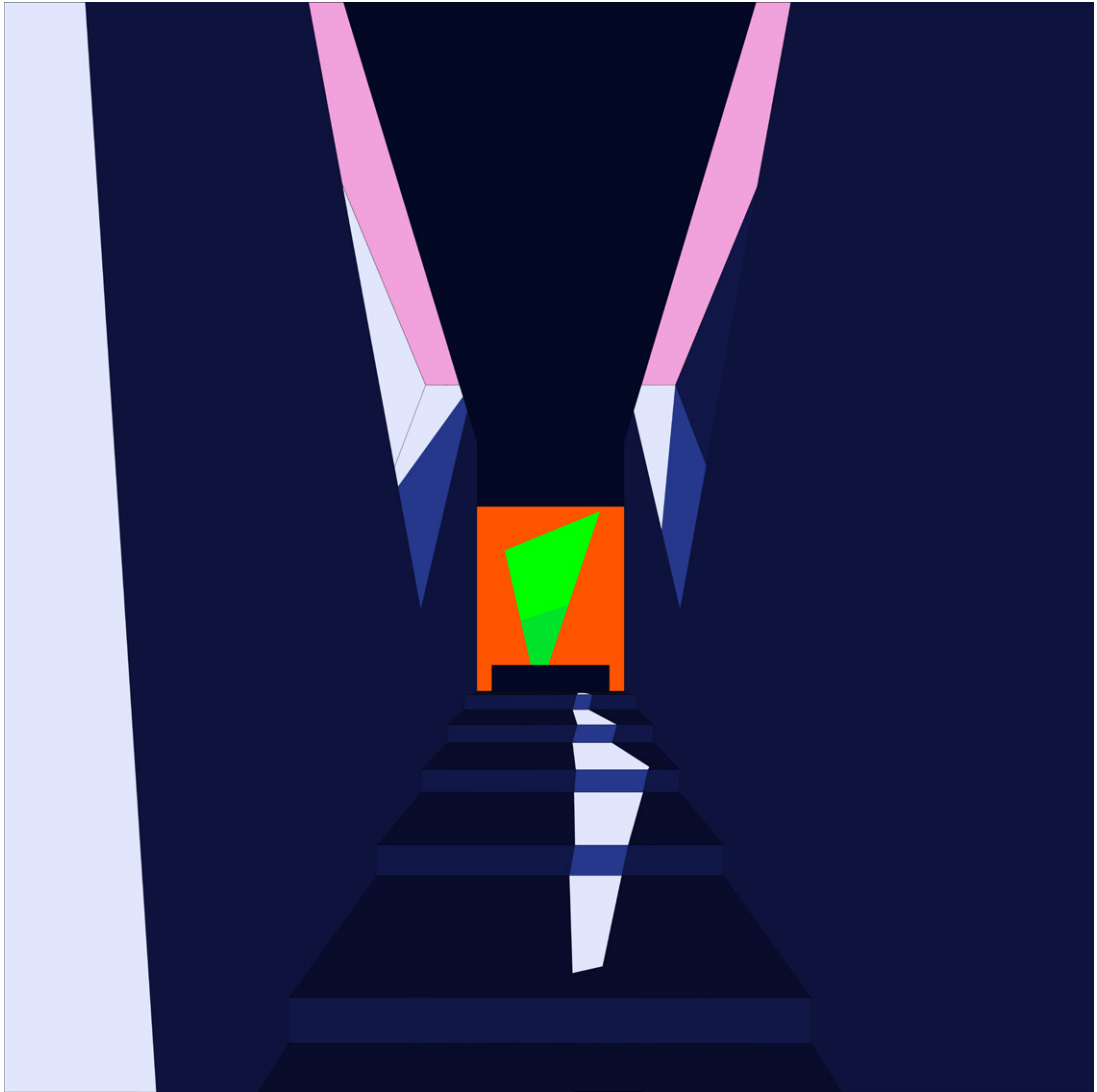

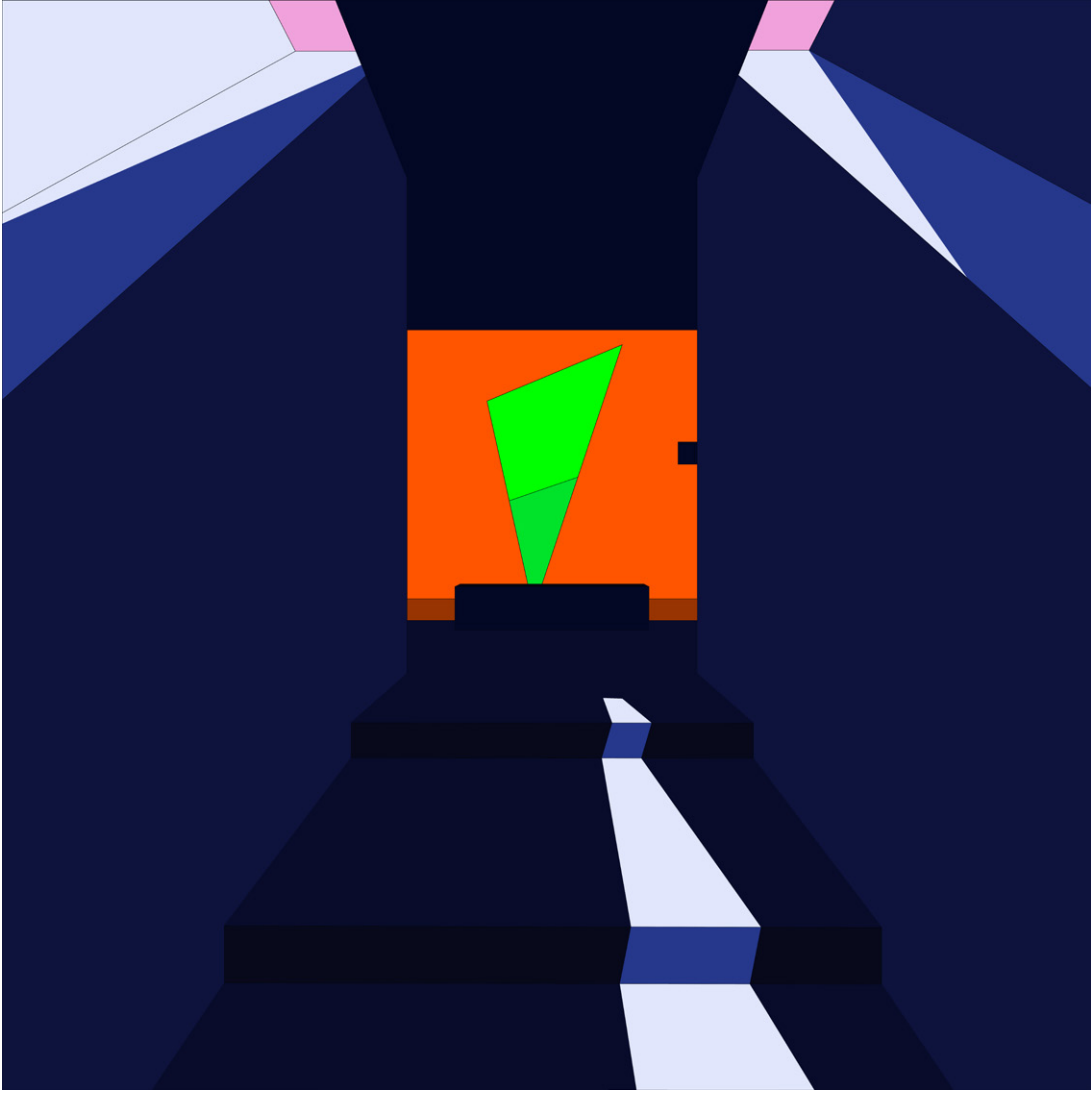

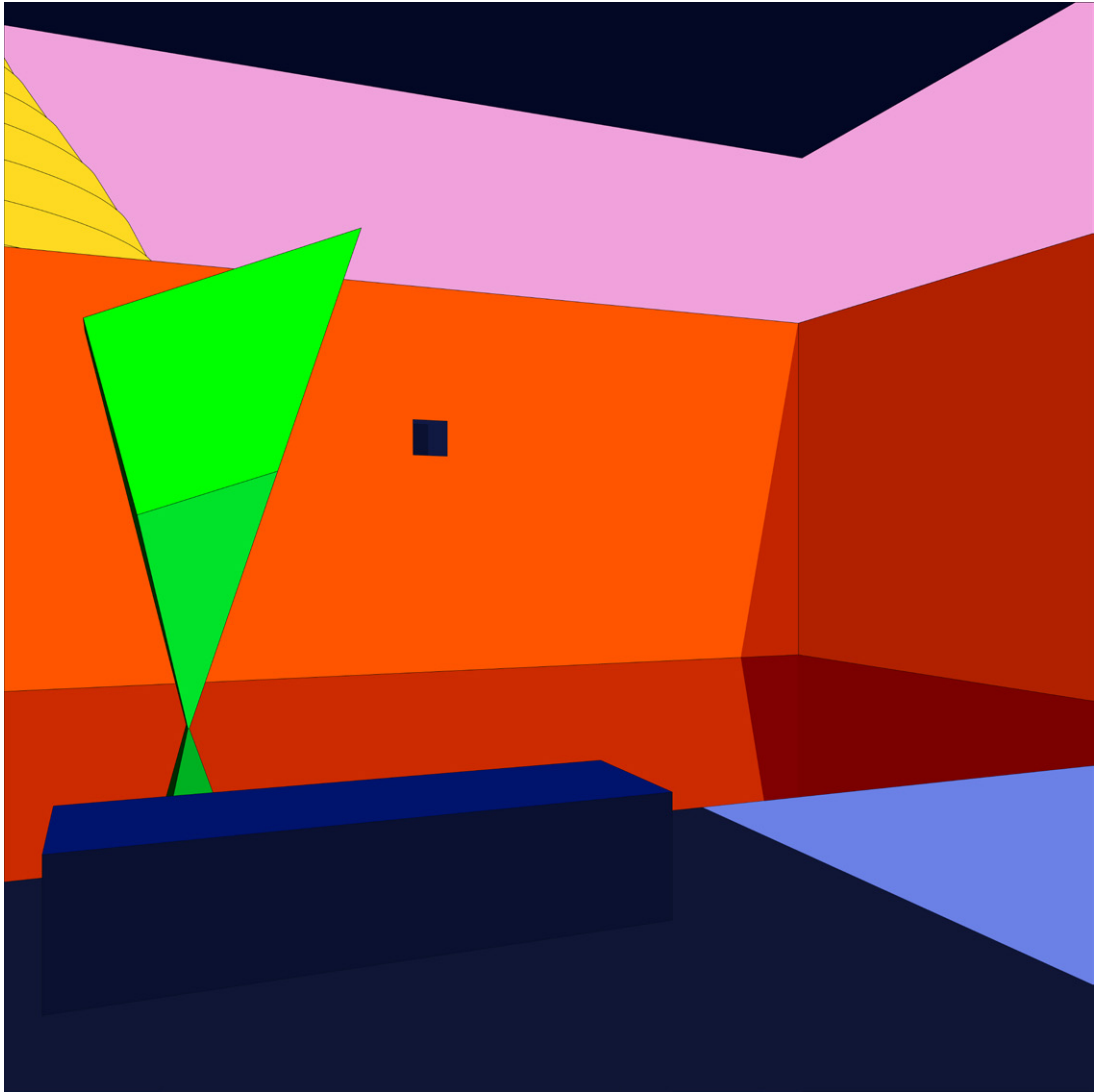

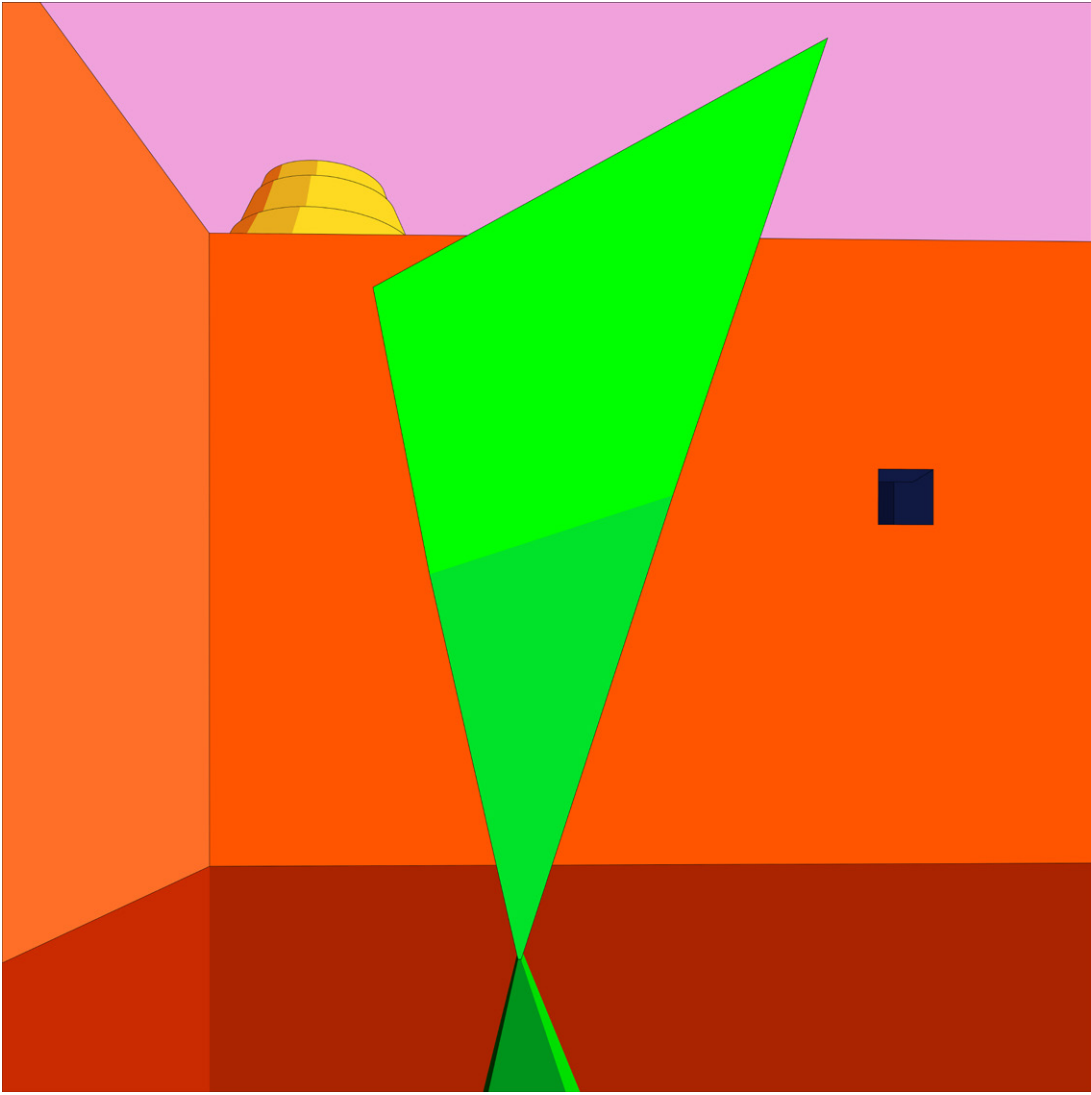

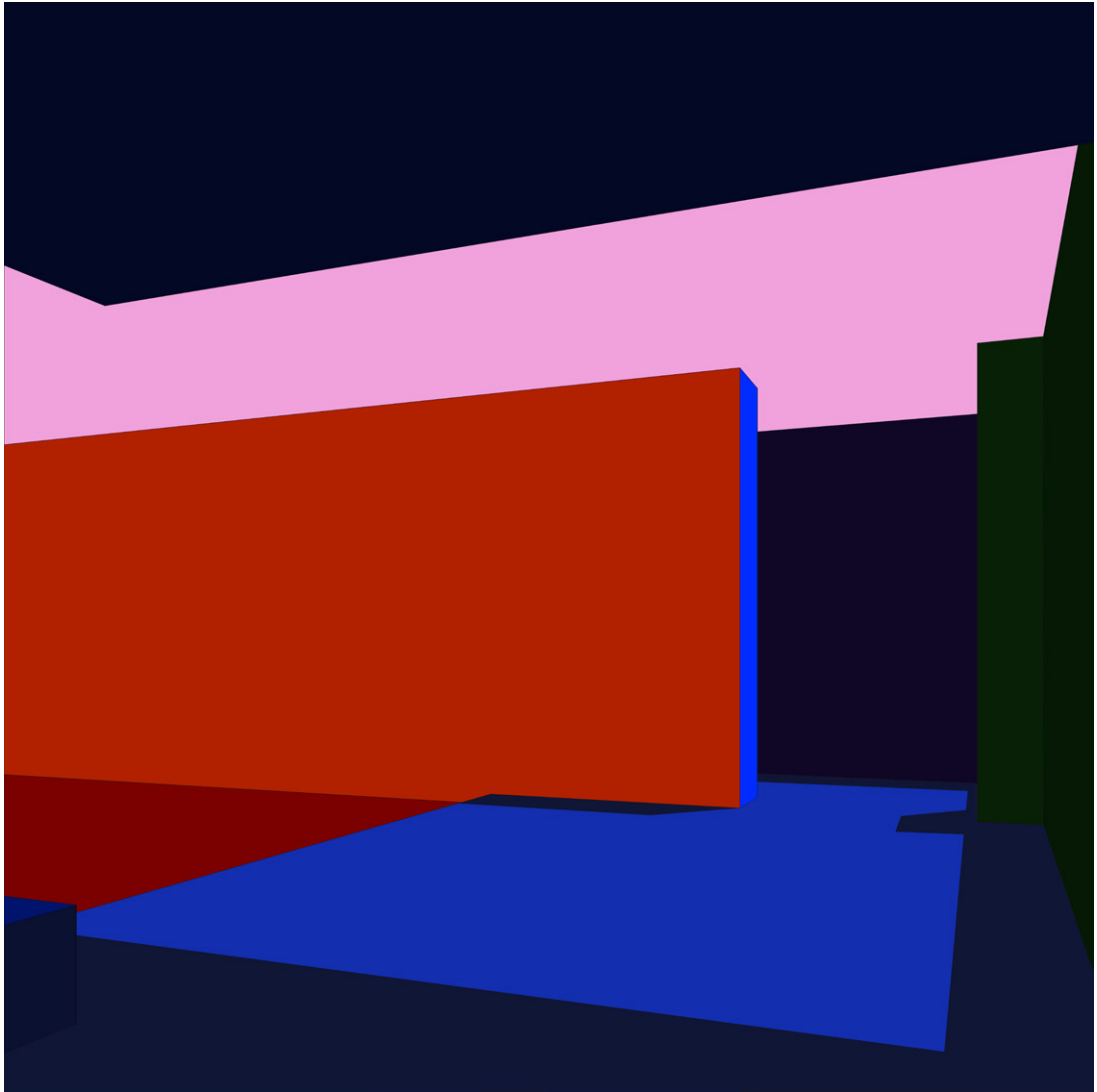

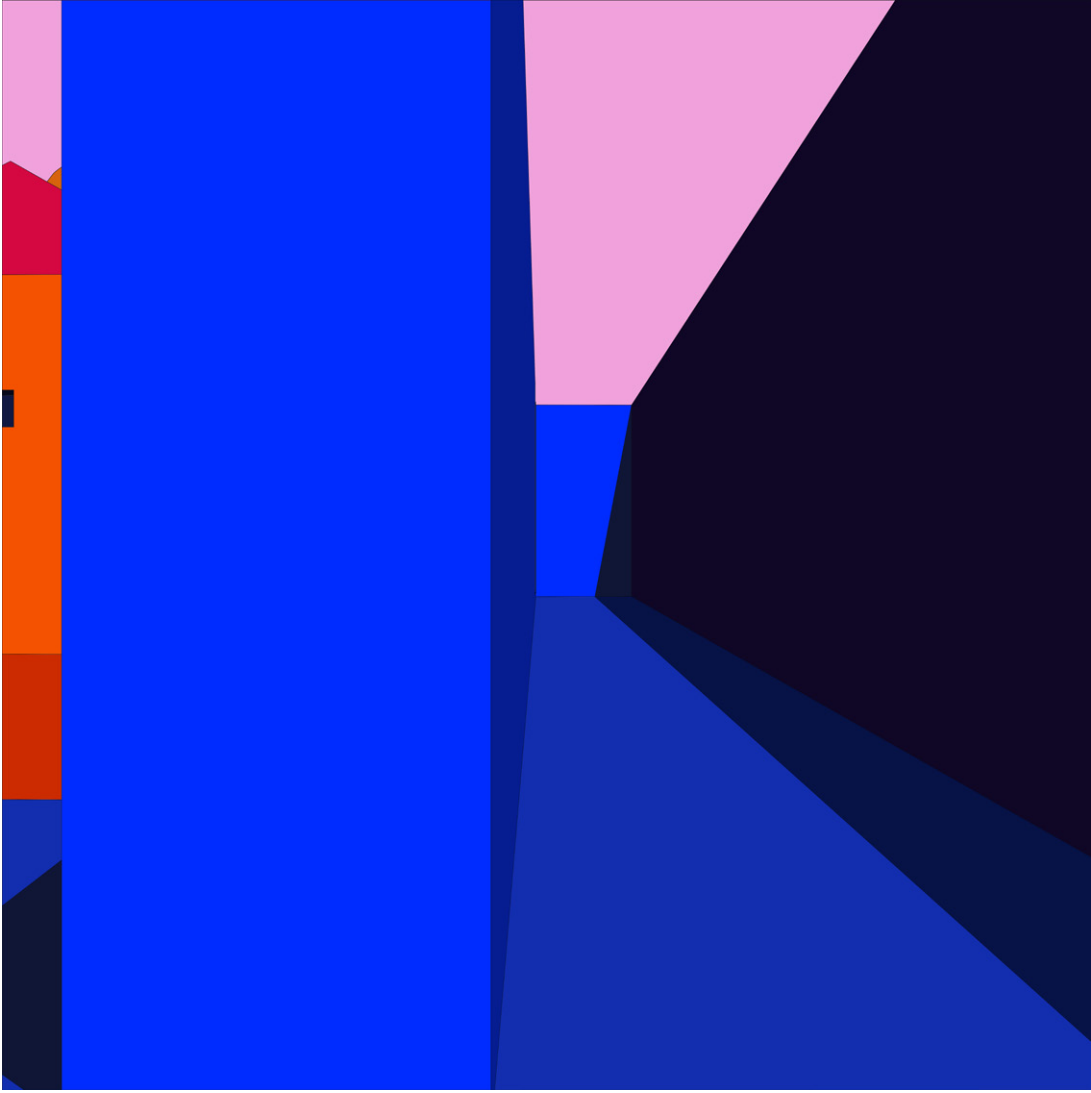

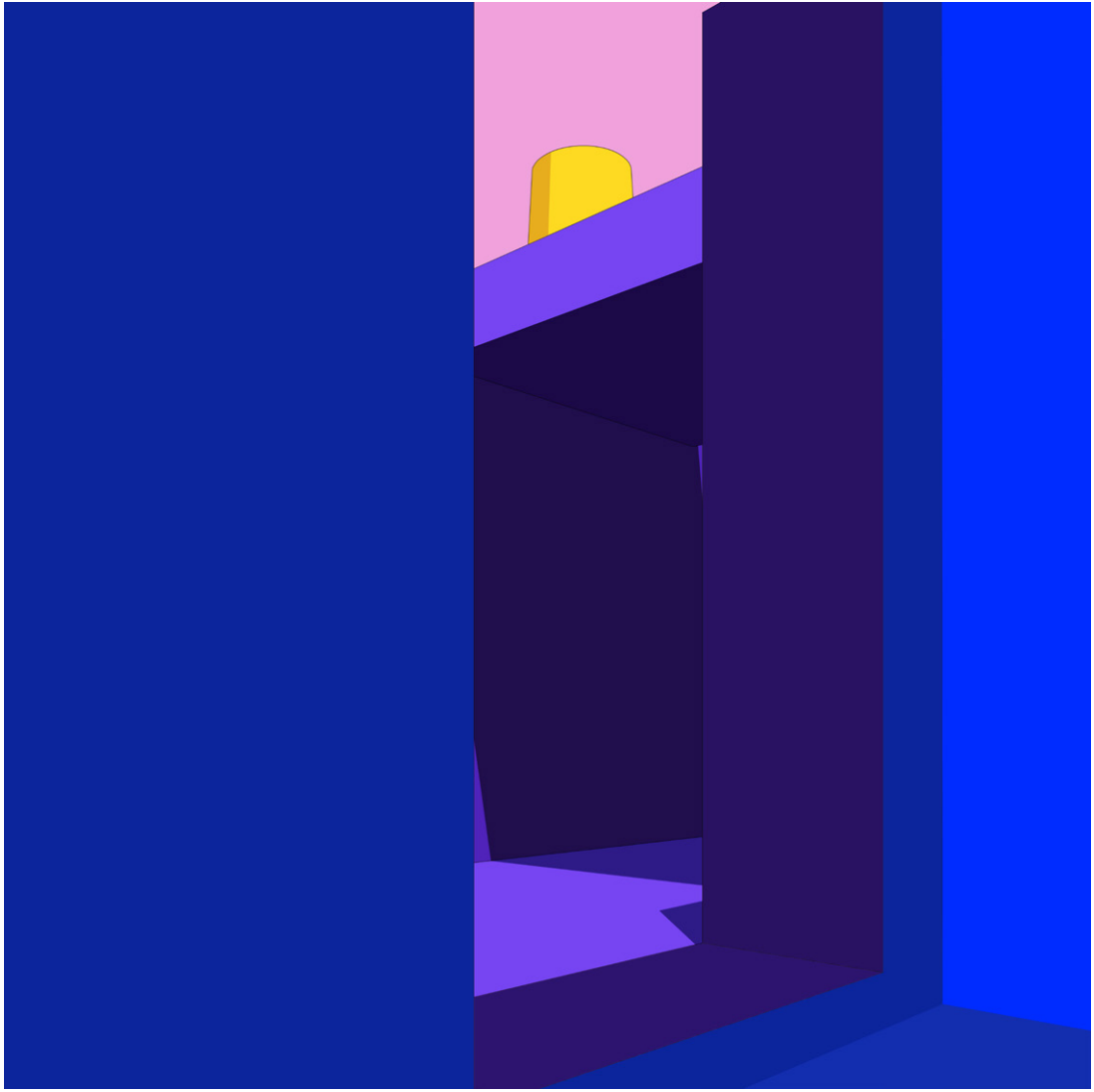

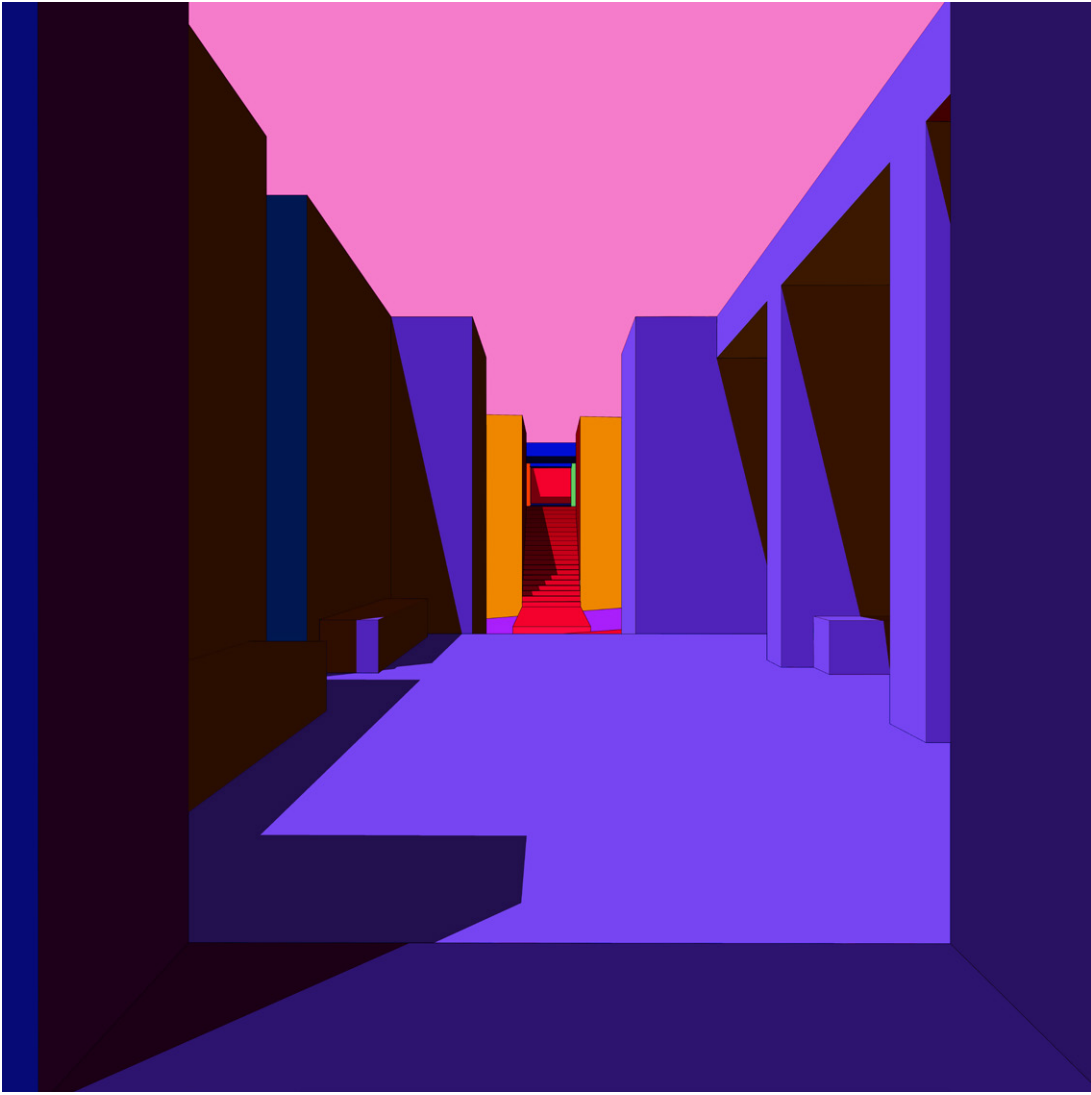

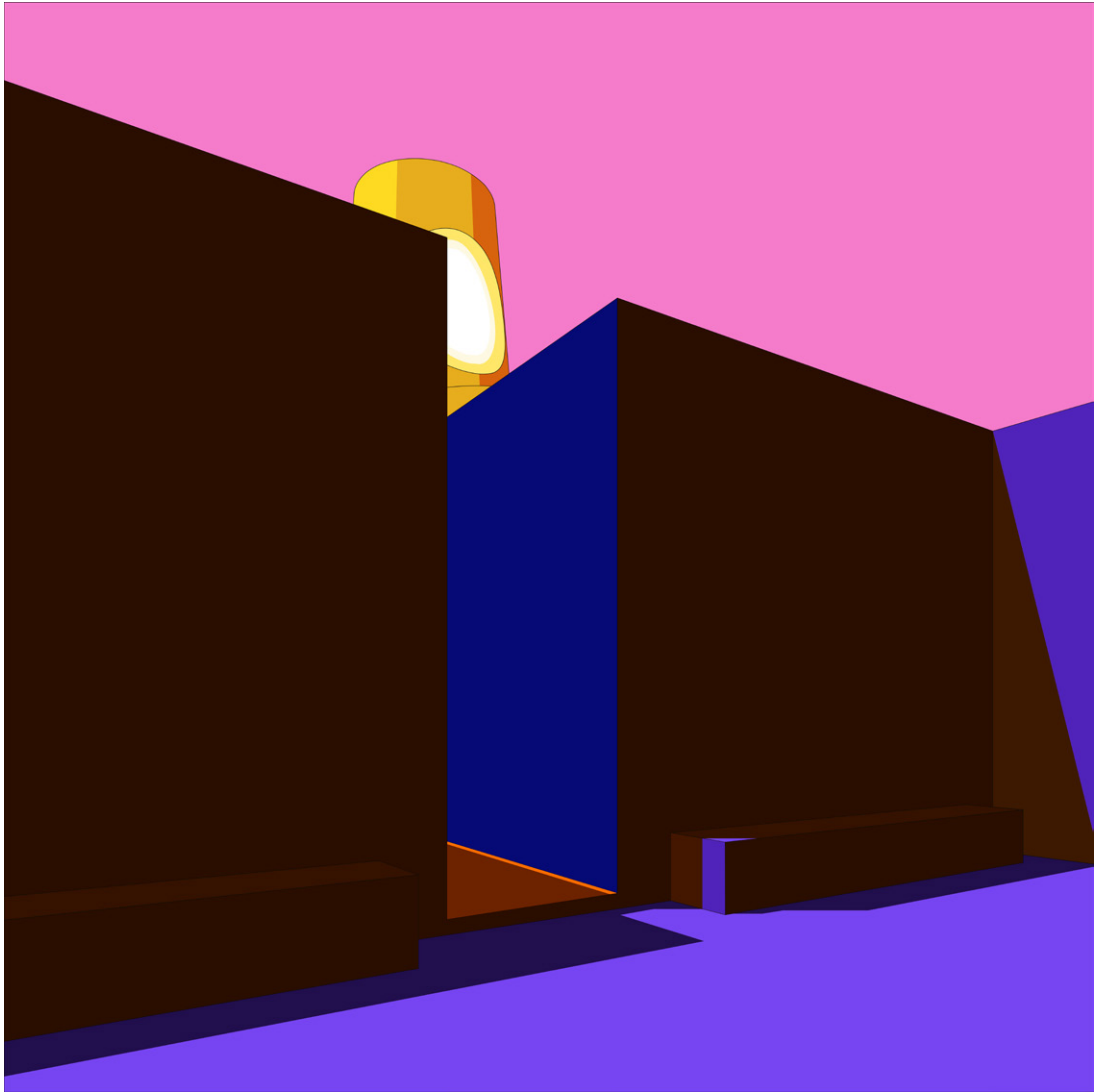

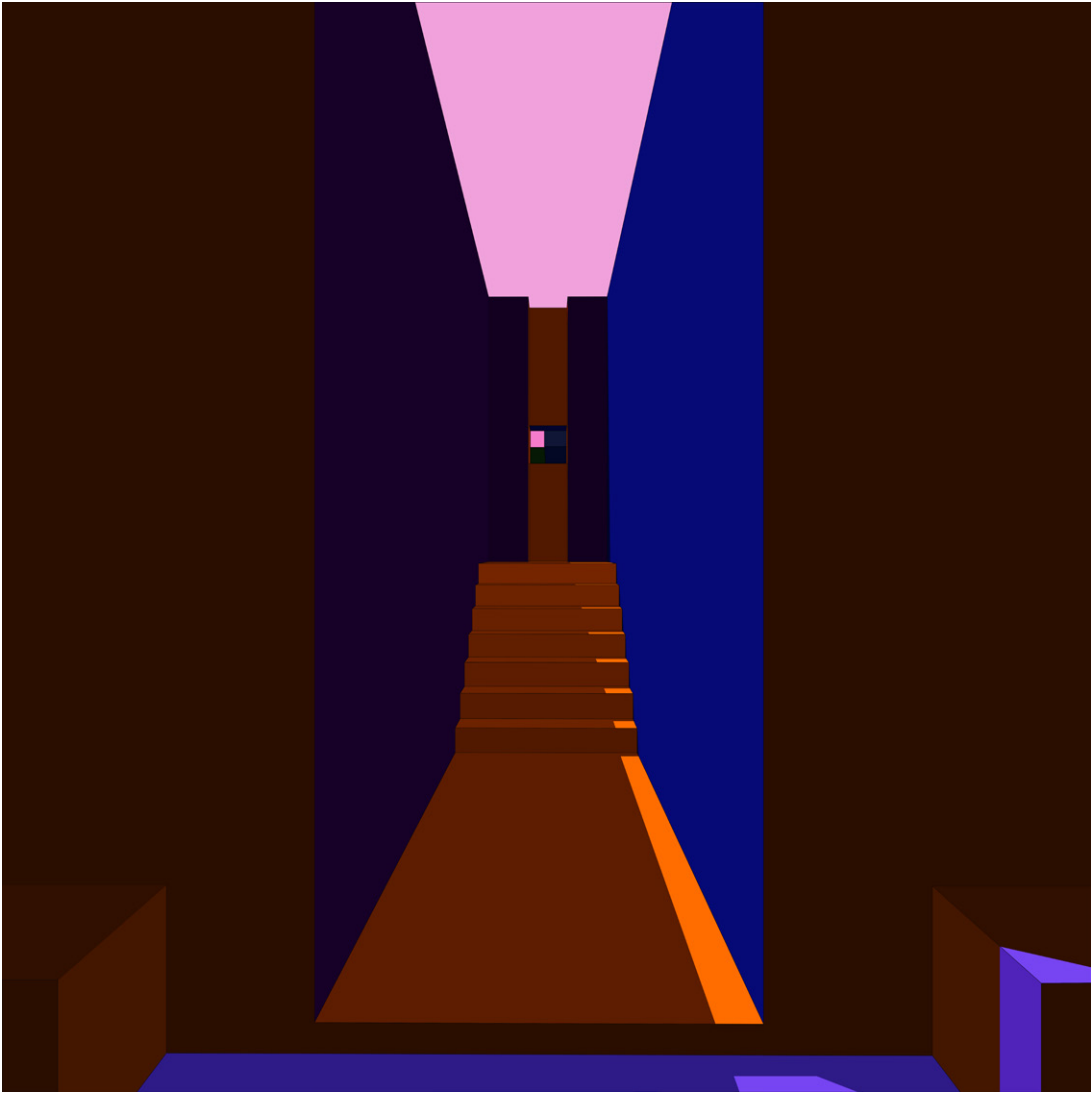

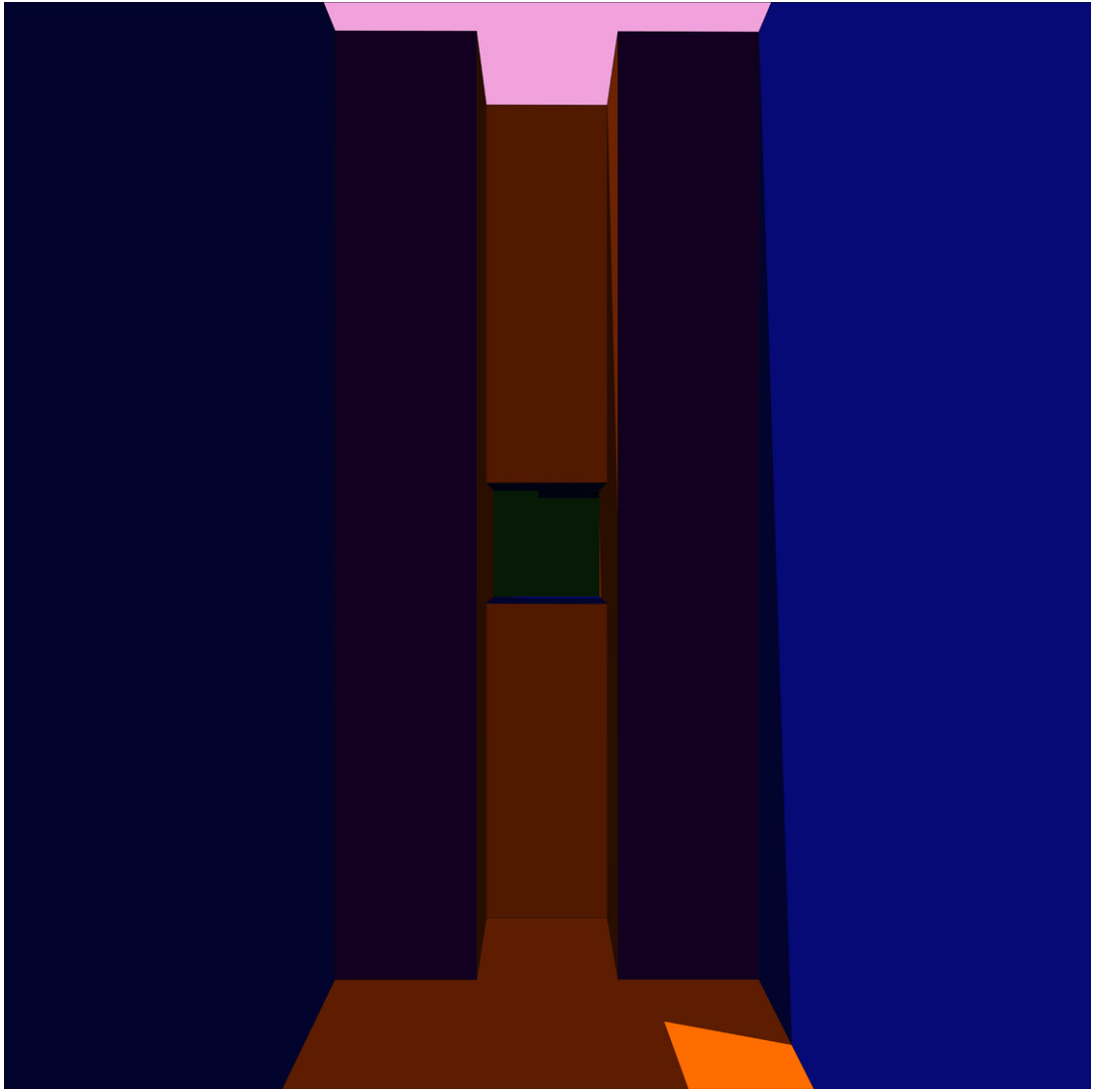

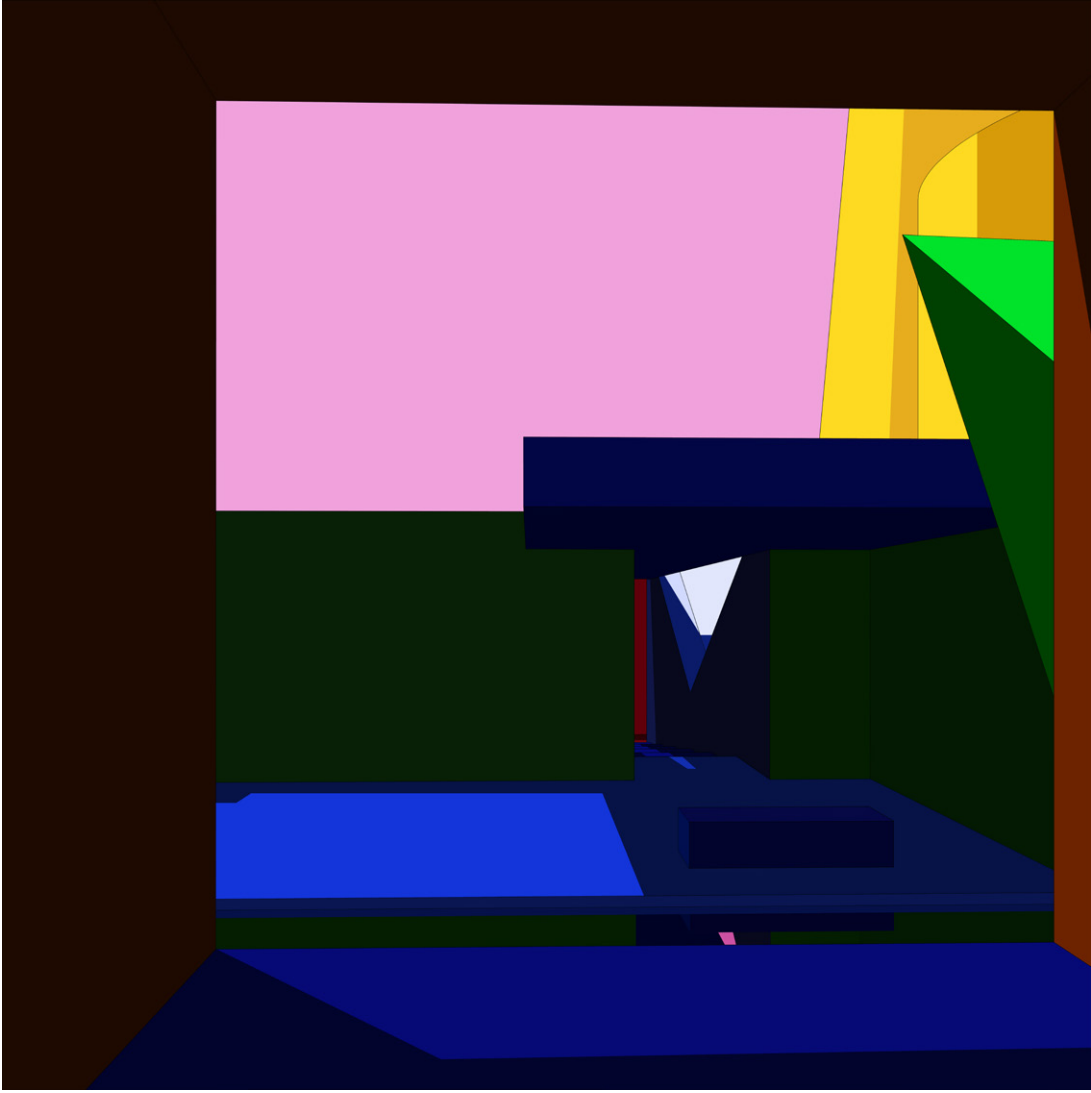

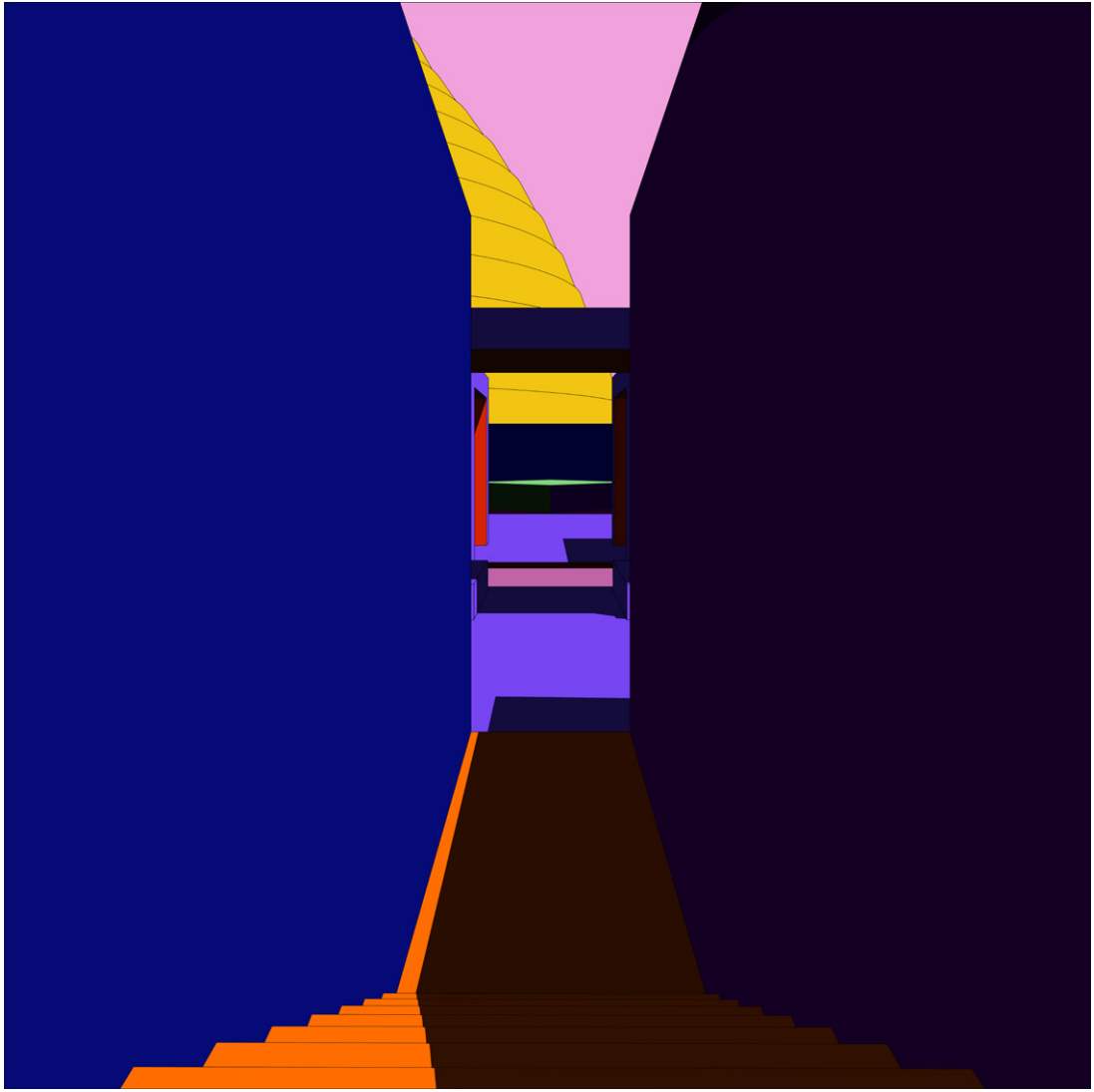

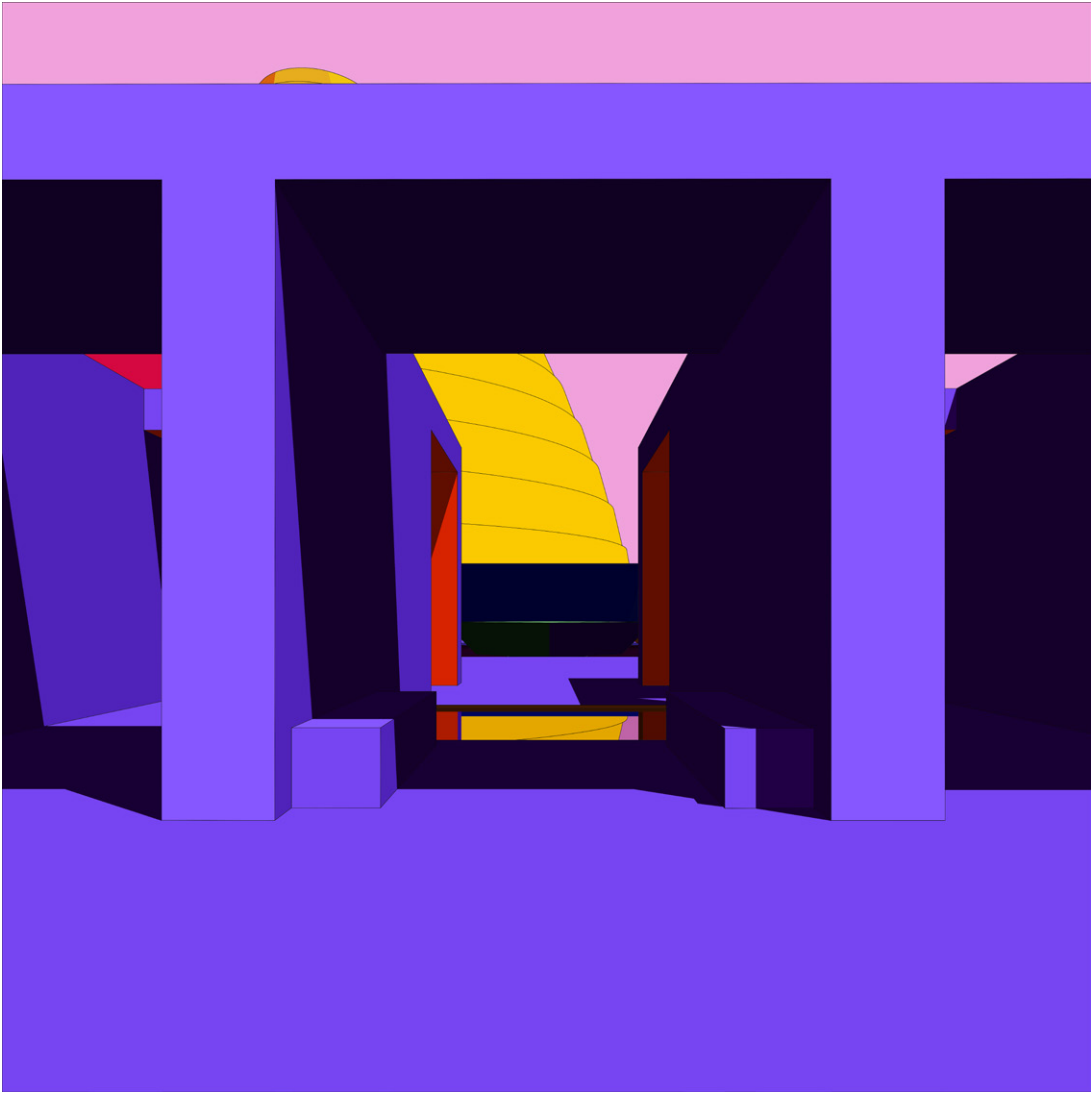

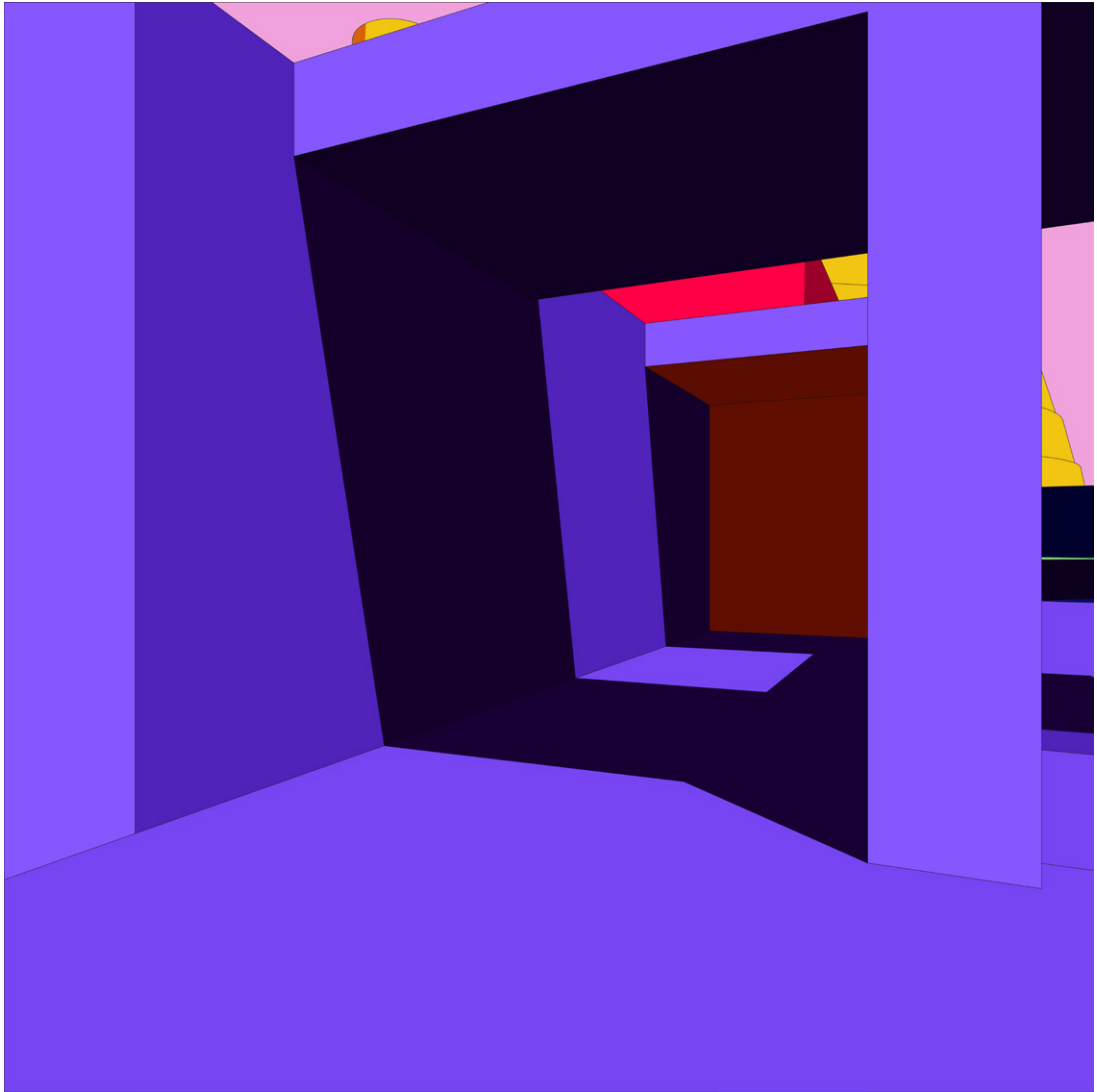



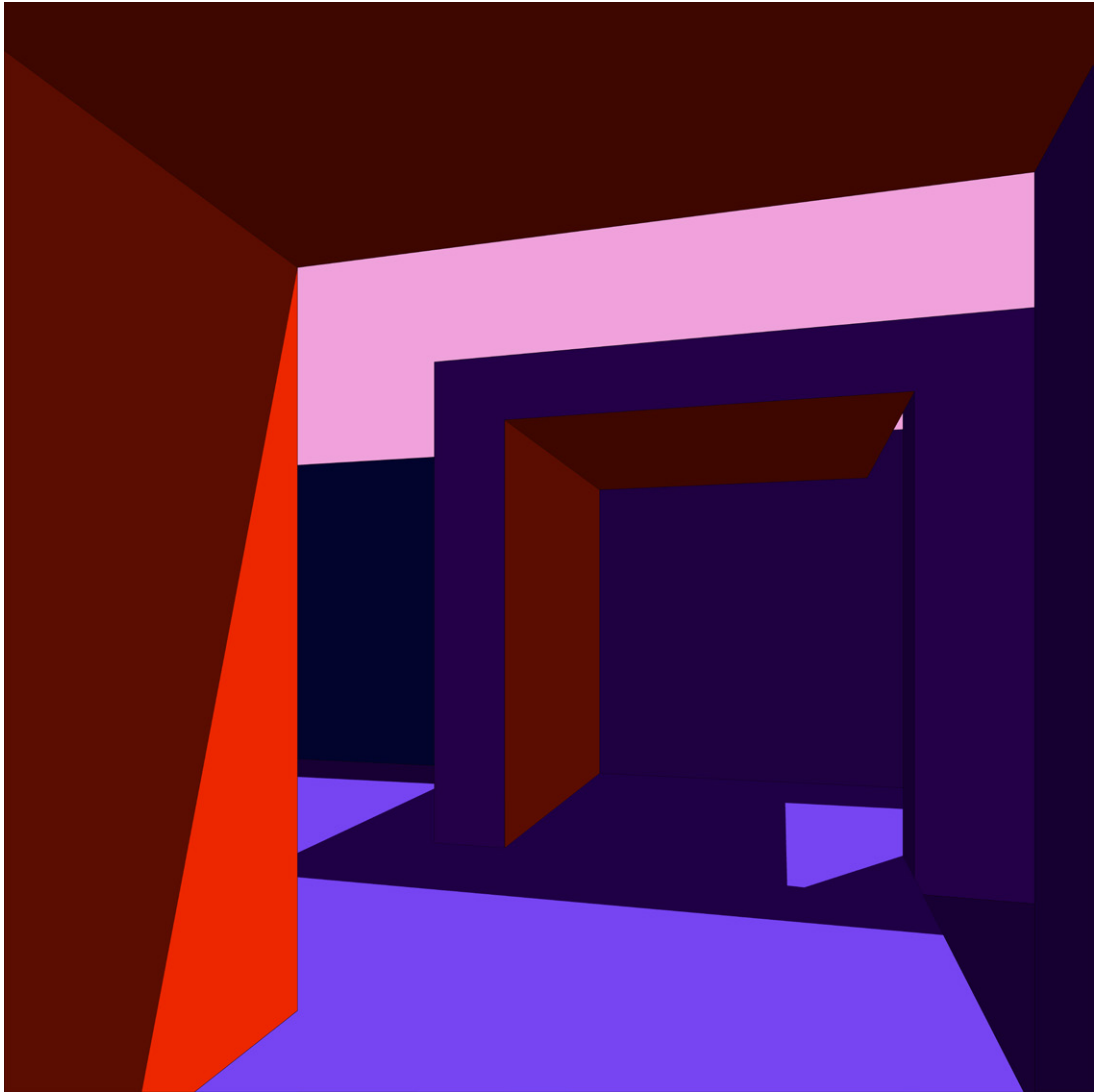

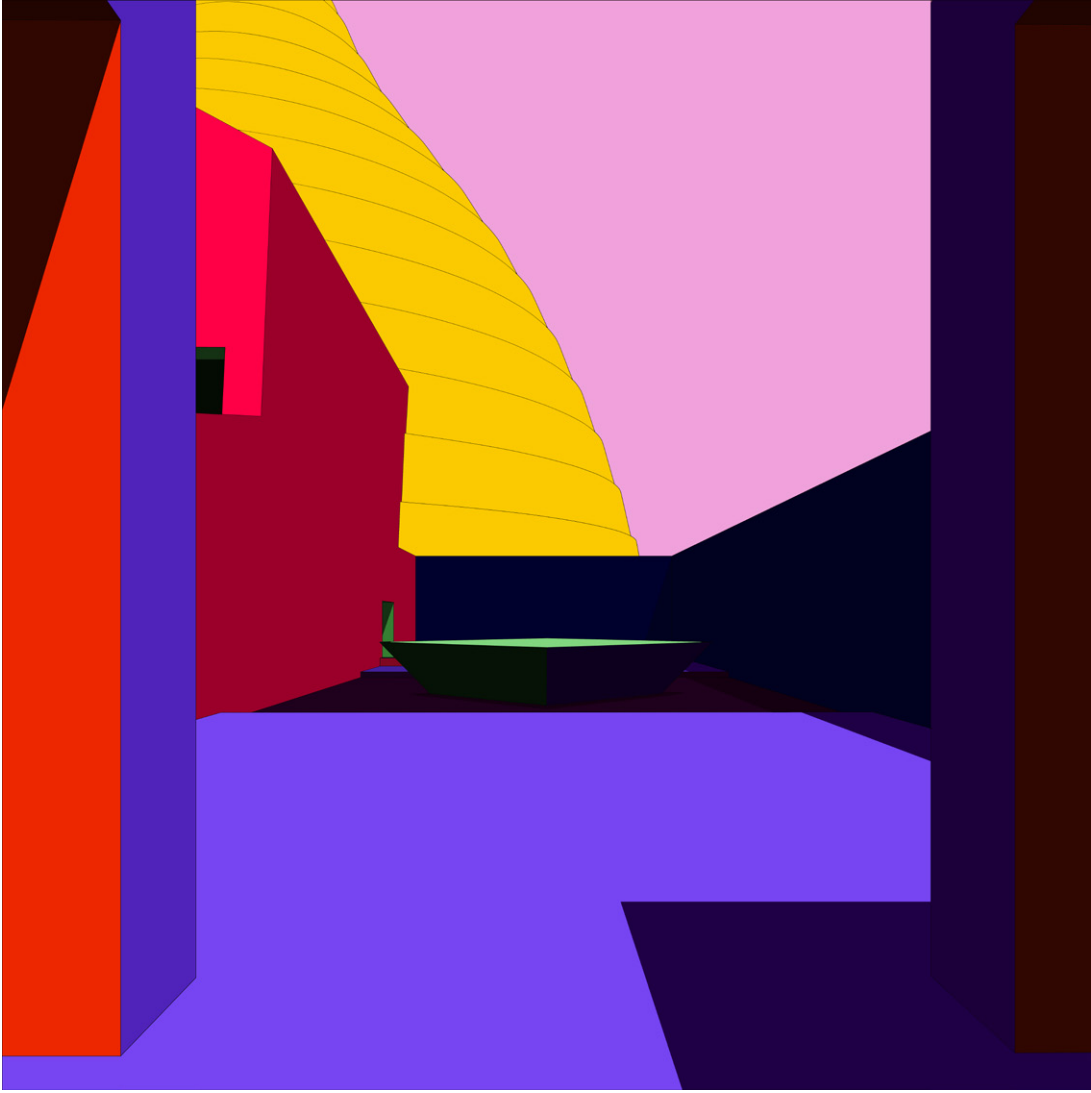

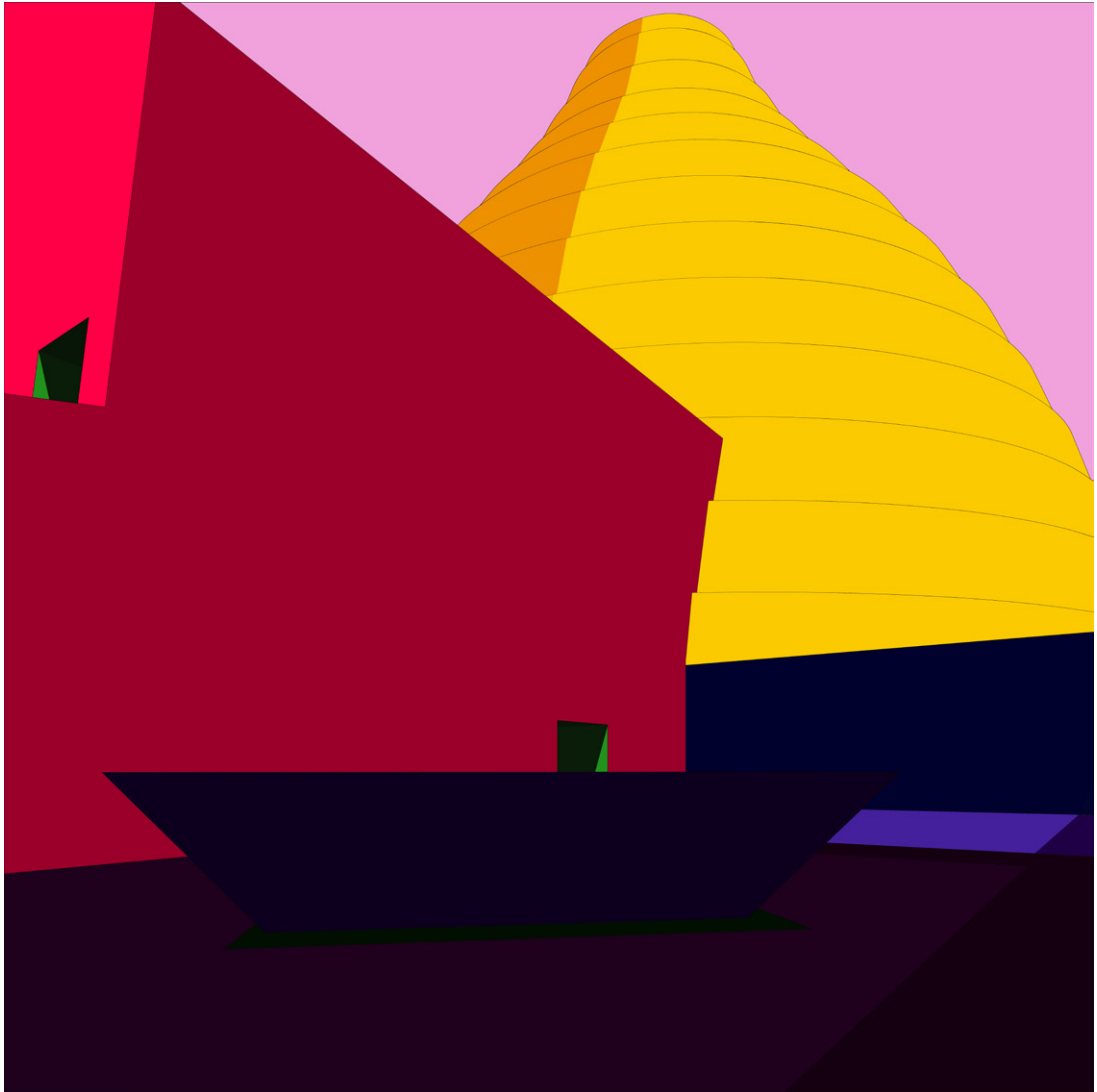

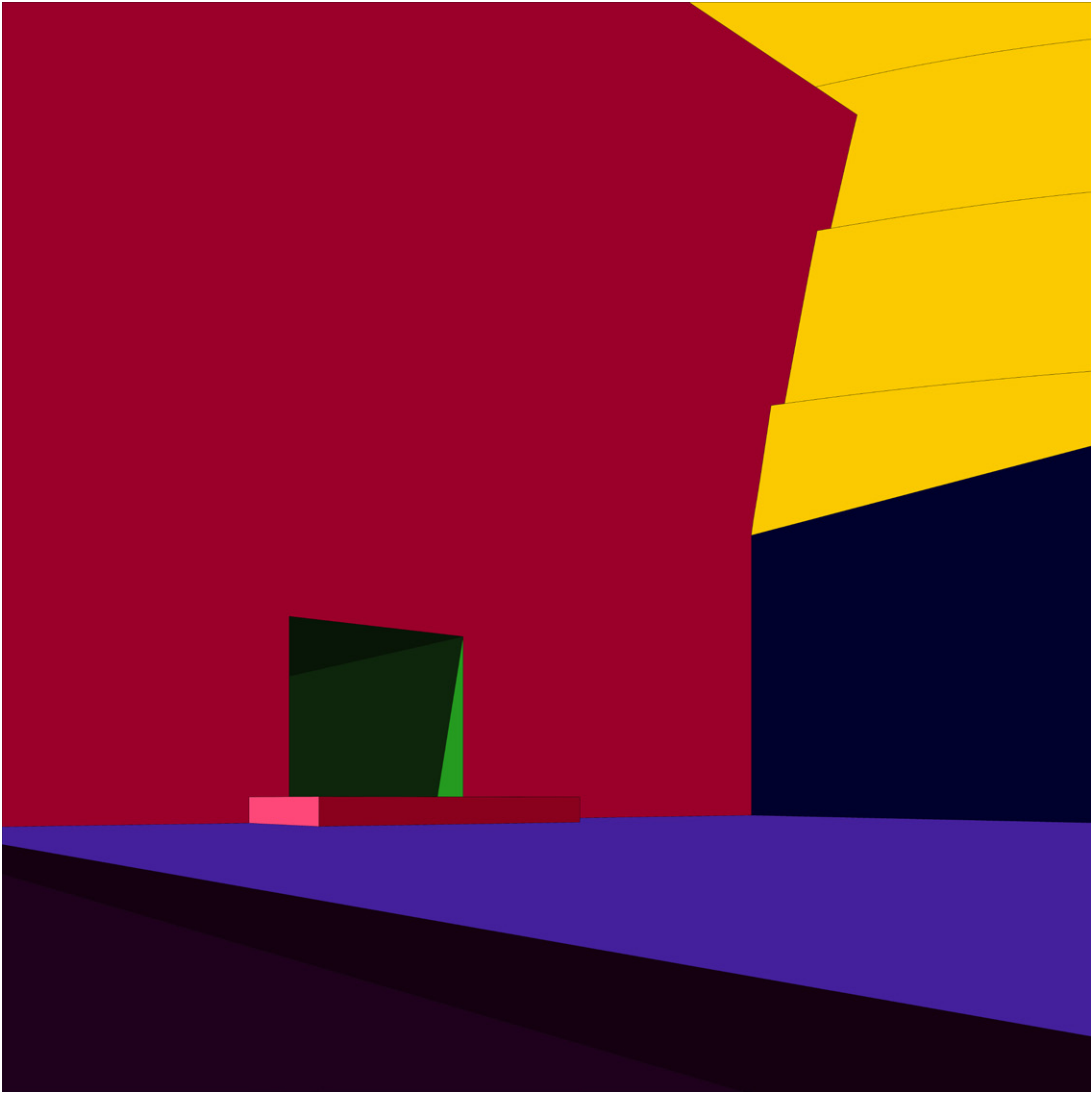

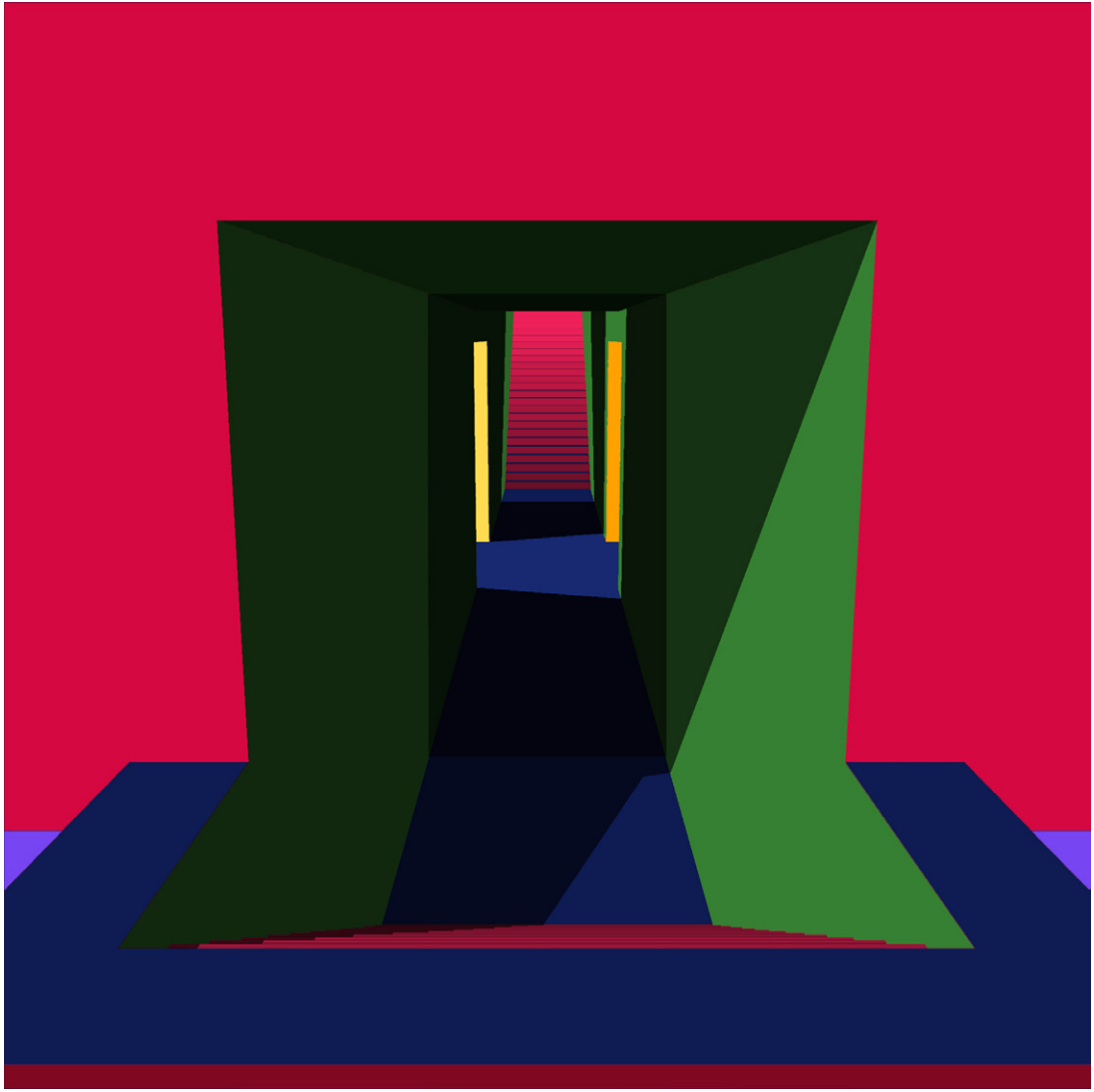

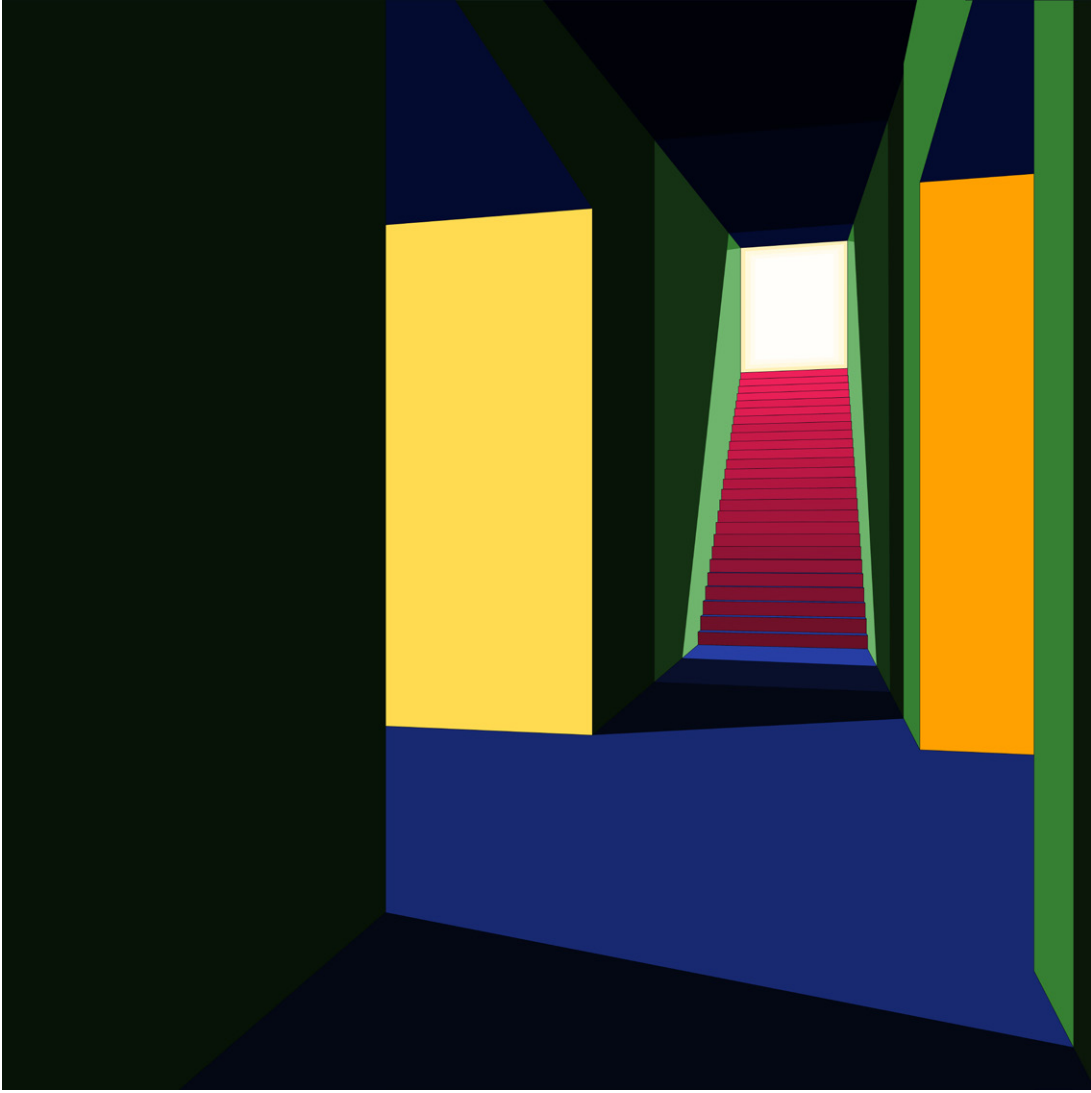

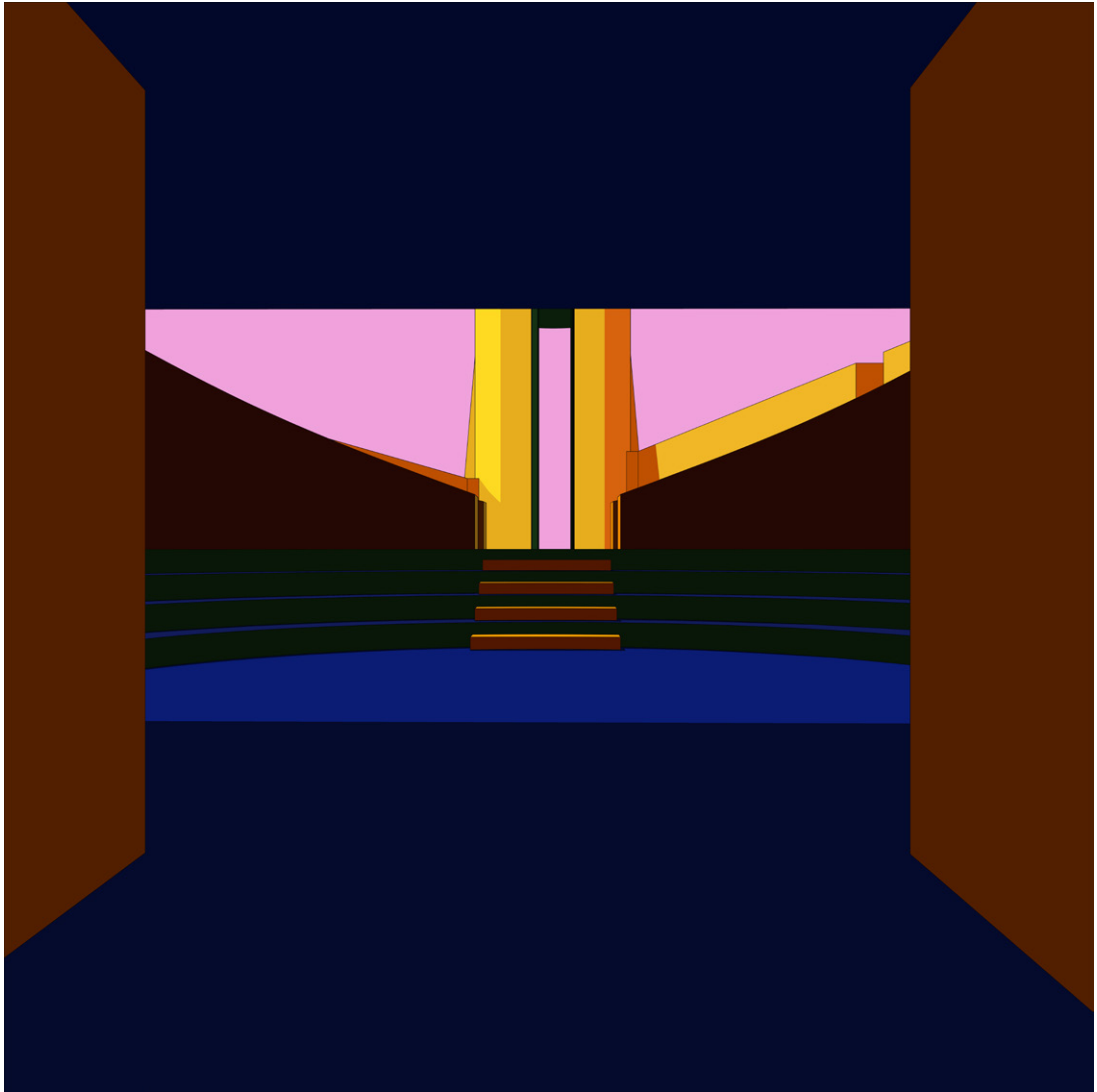

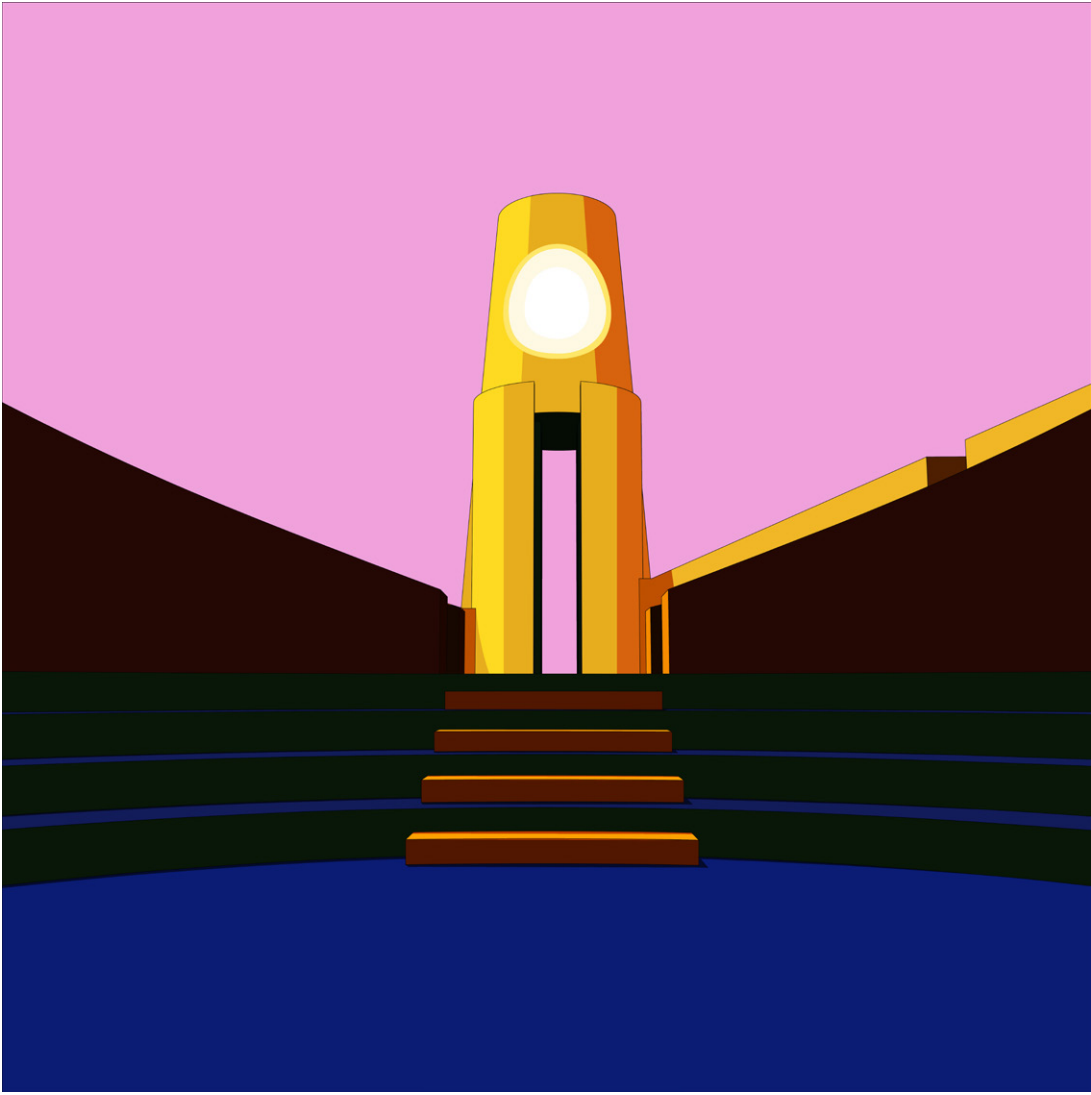





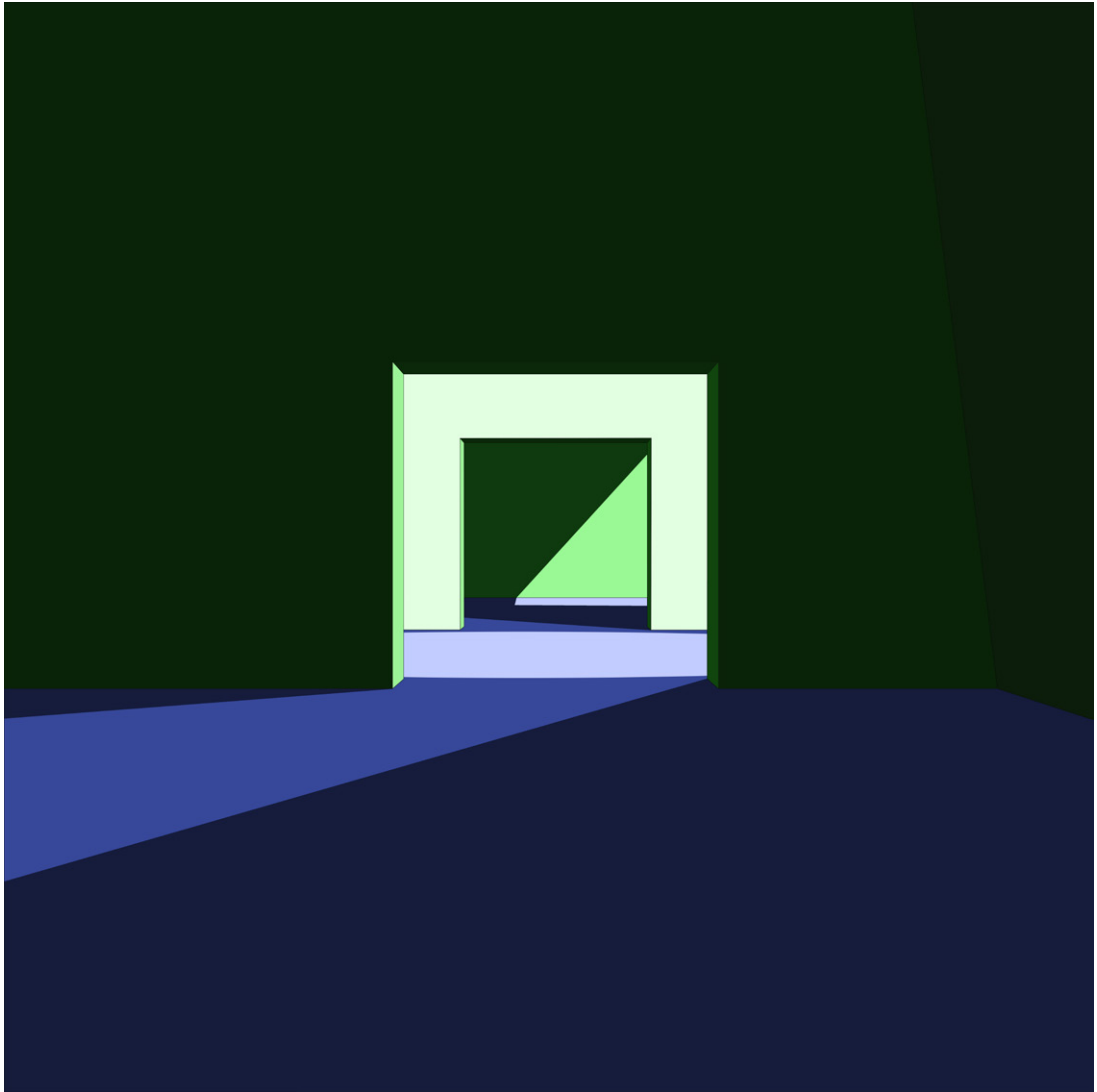

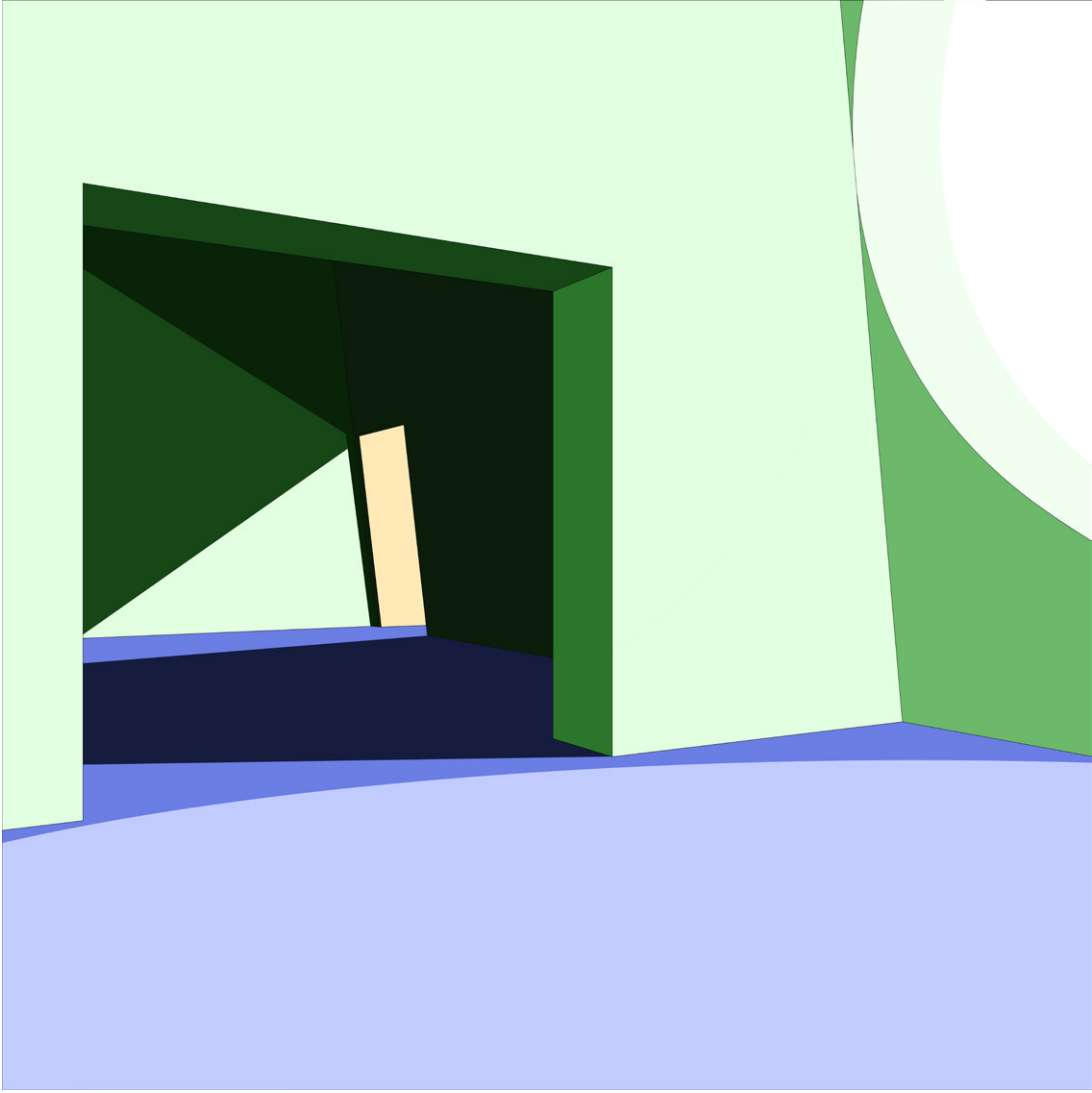

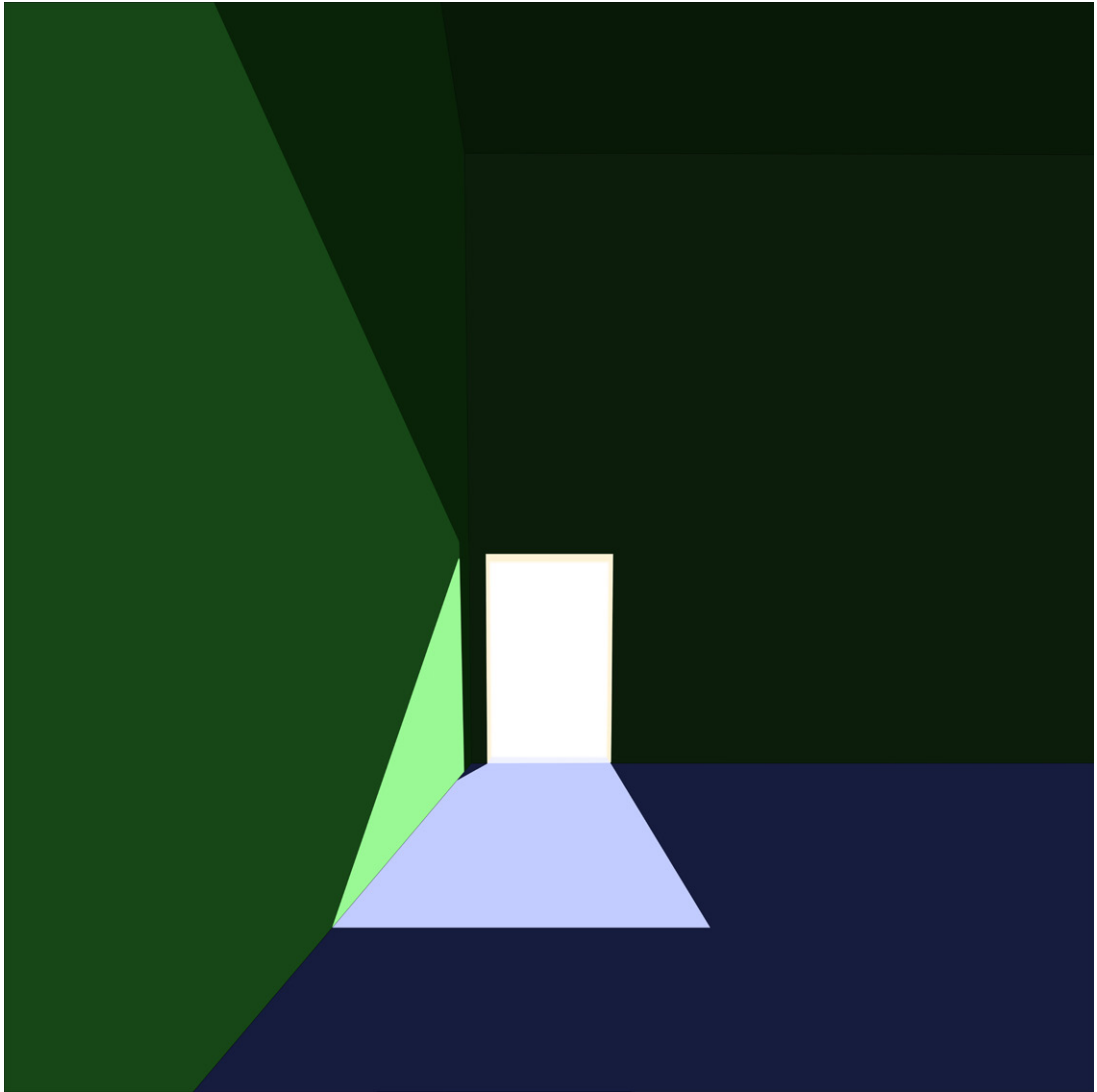



ITERATION 6. COLOR

walk (3)

layers of complexity (space, form, light
and color)

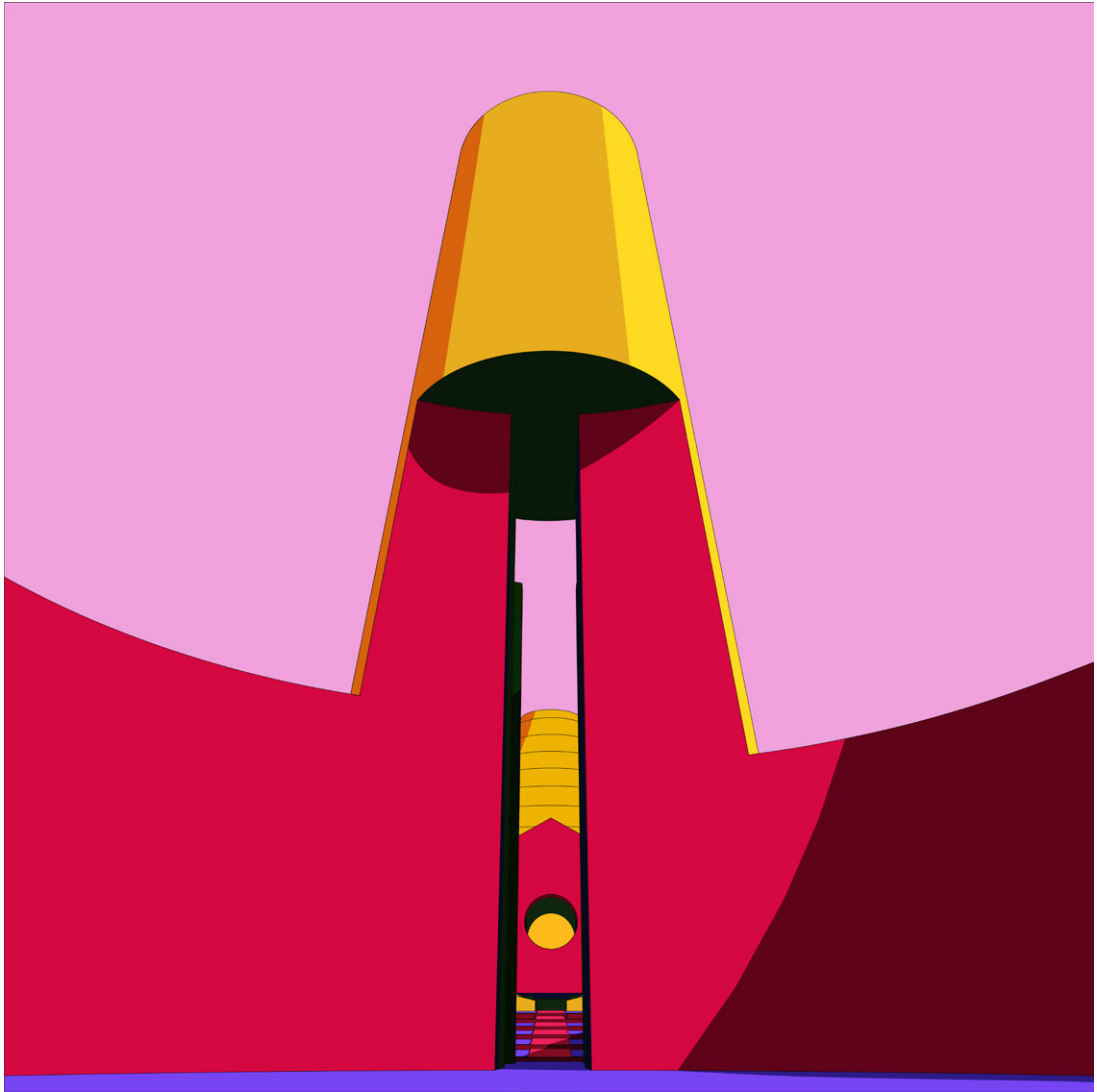

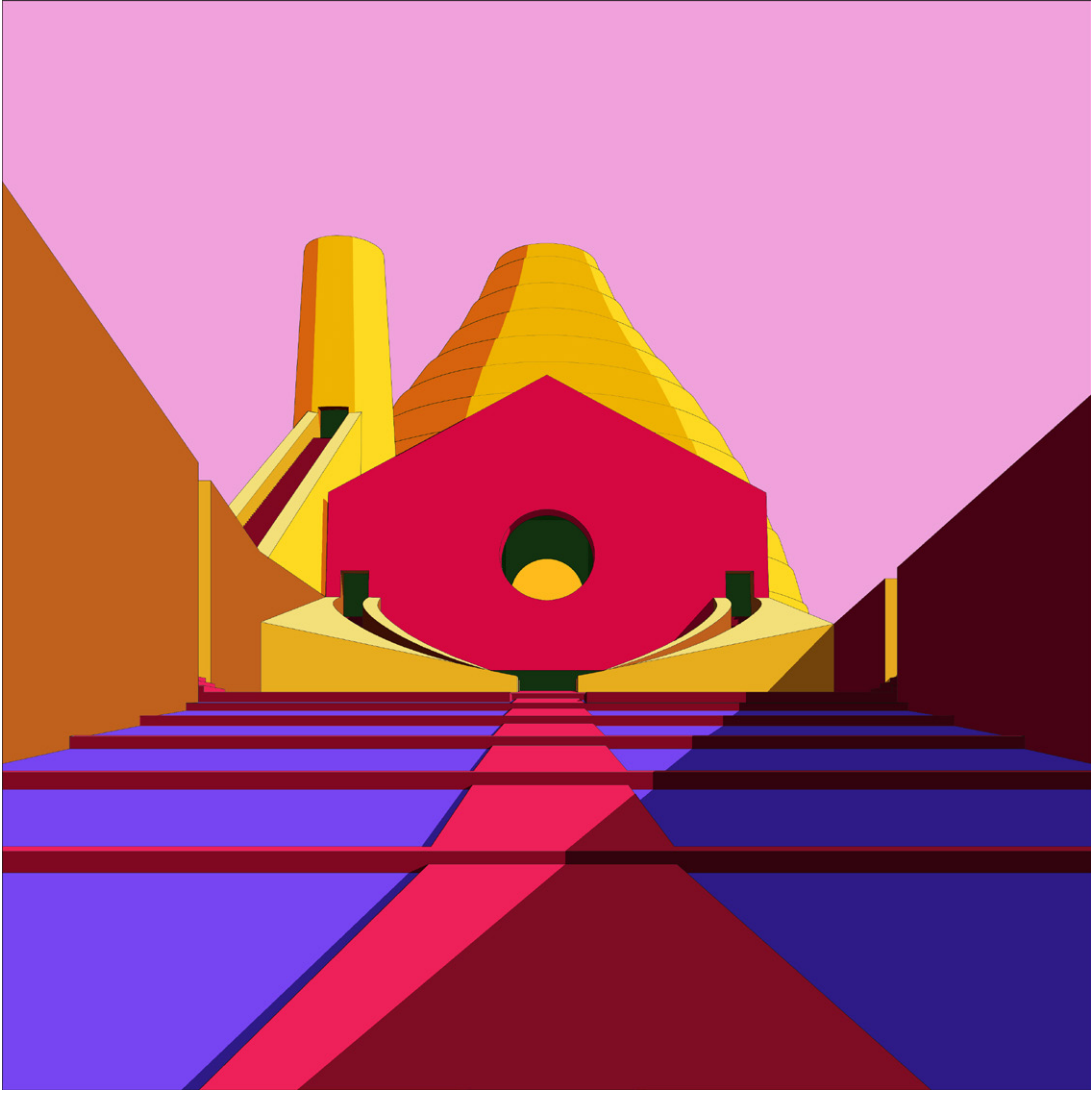



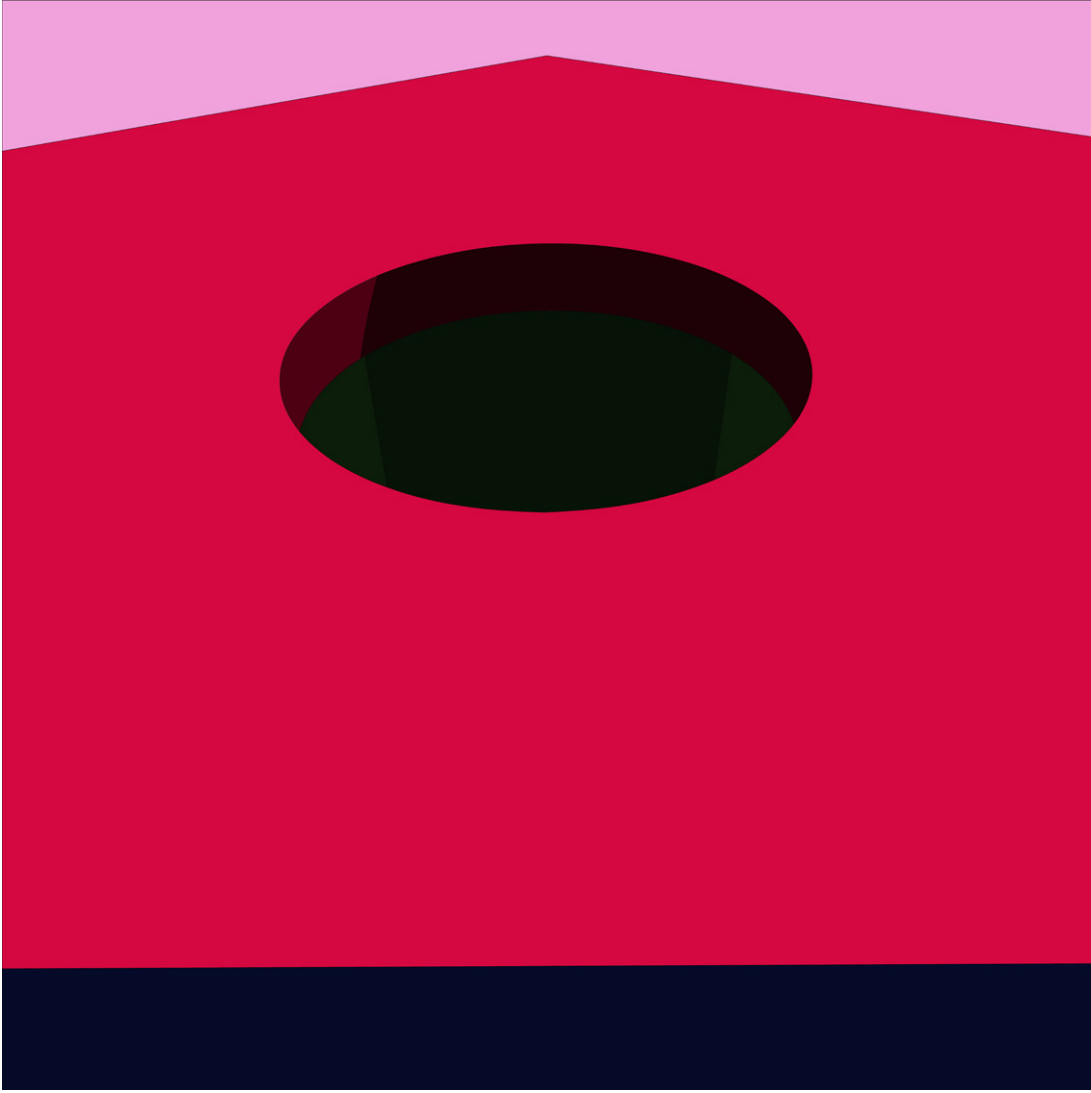

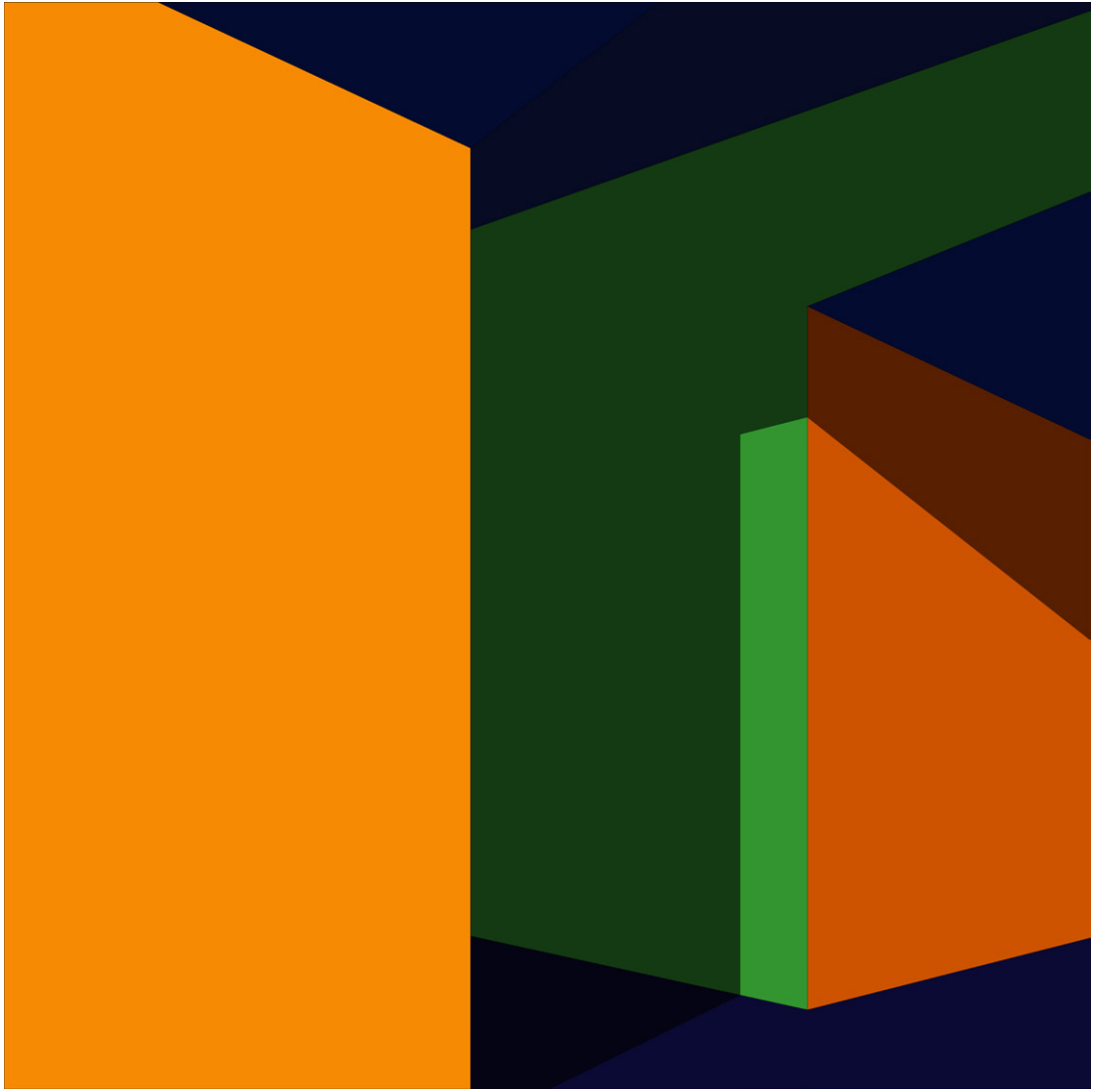

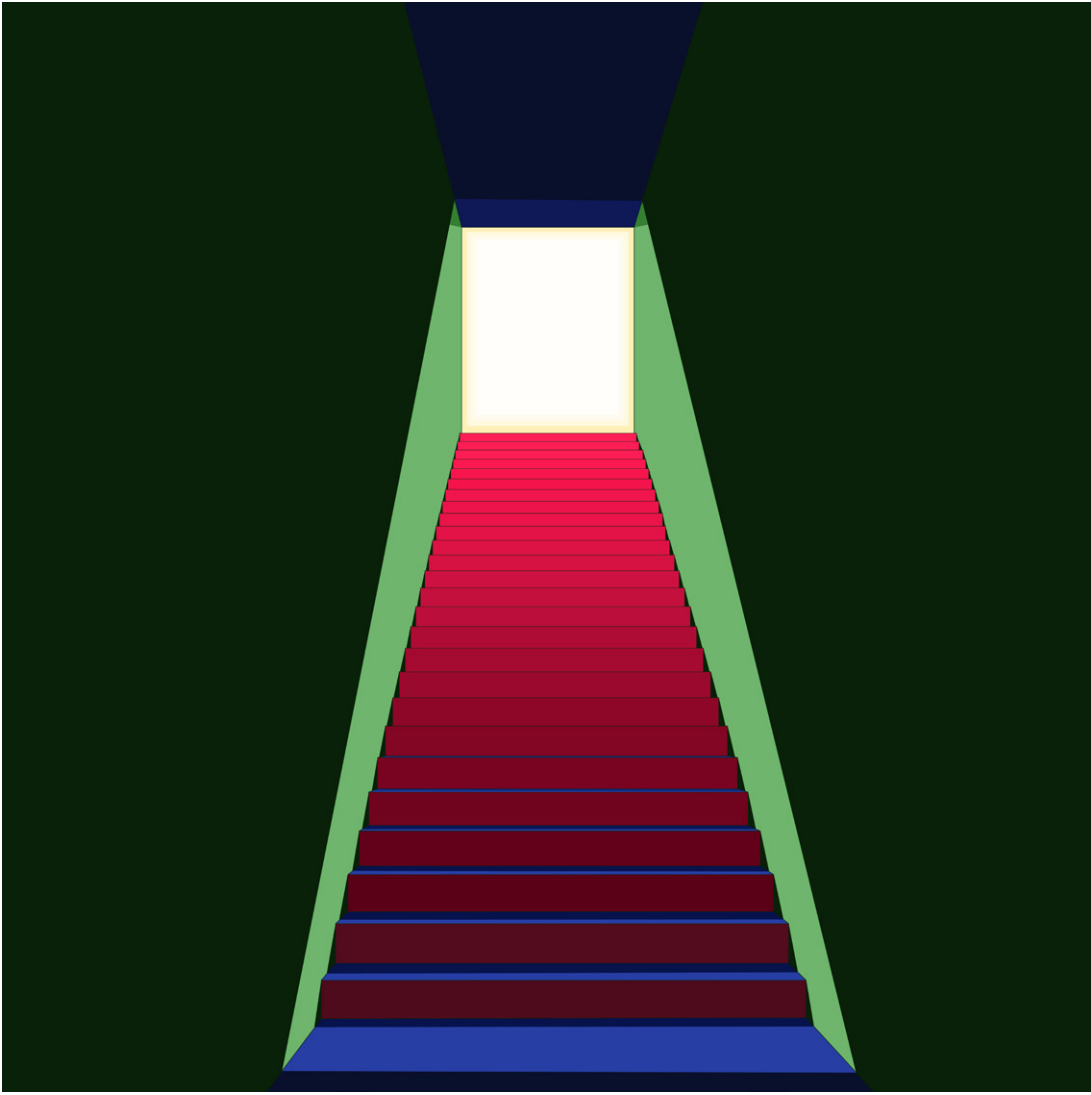

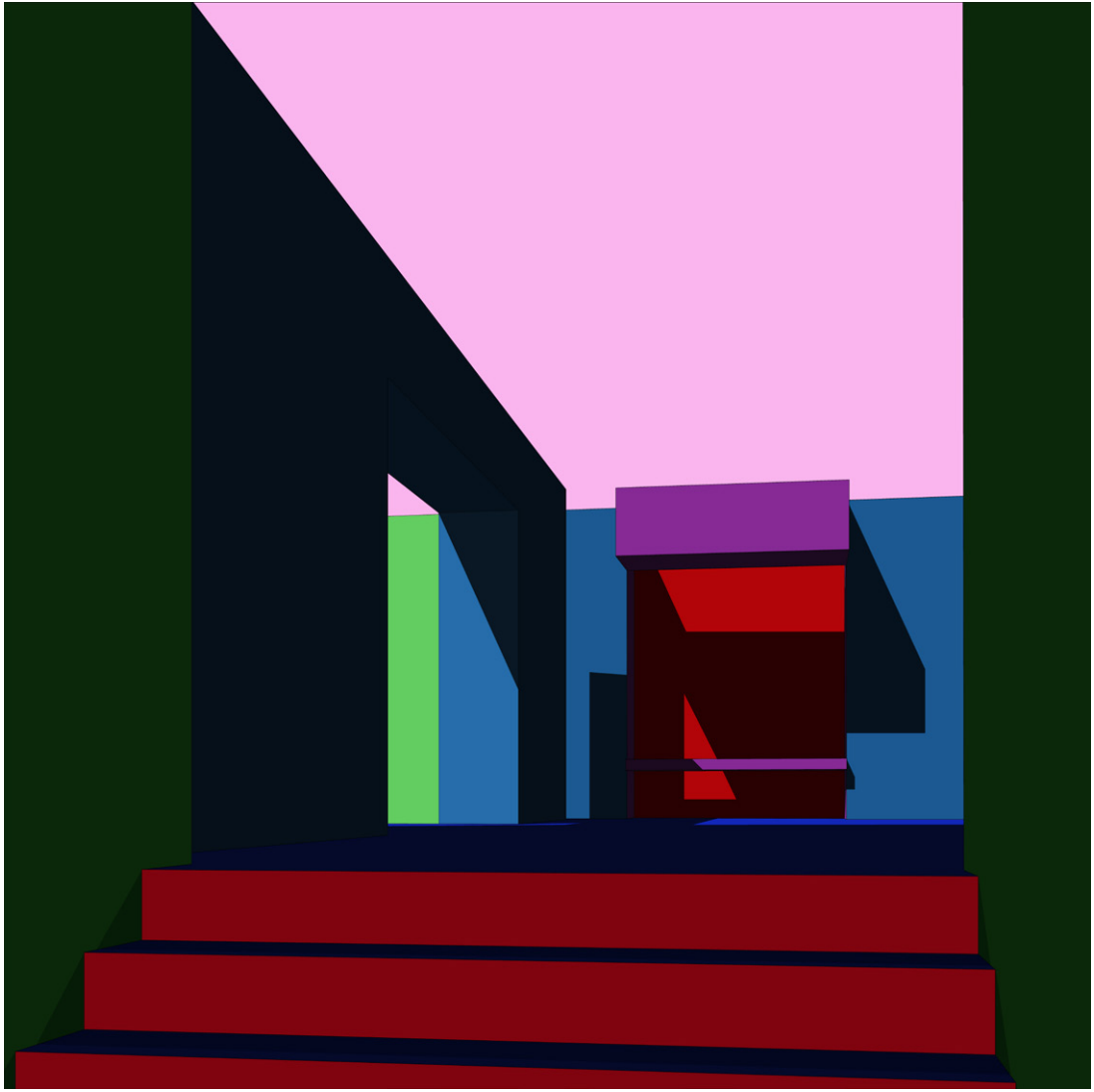

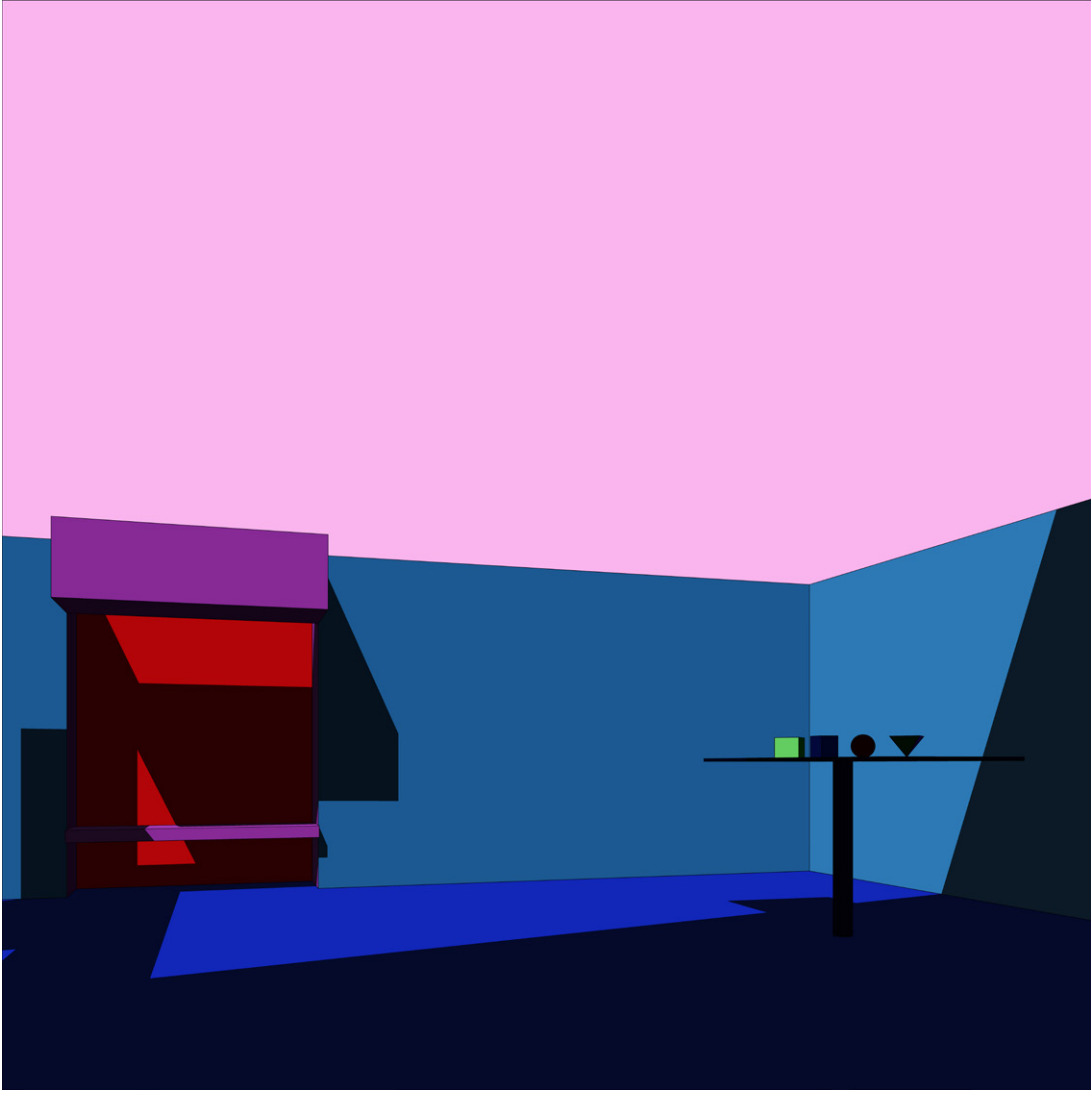

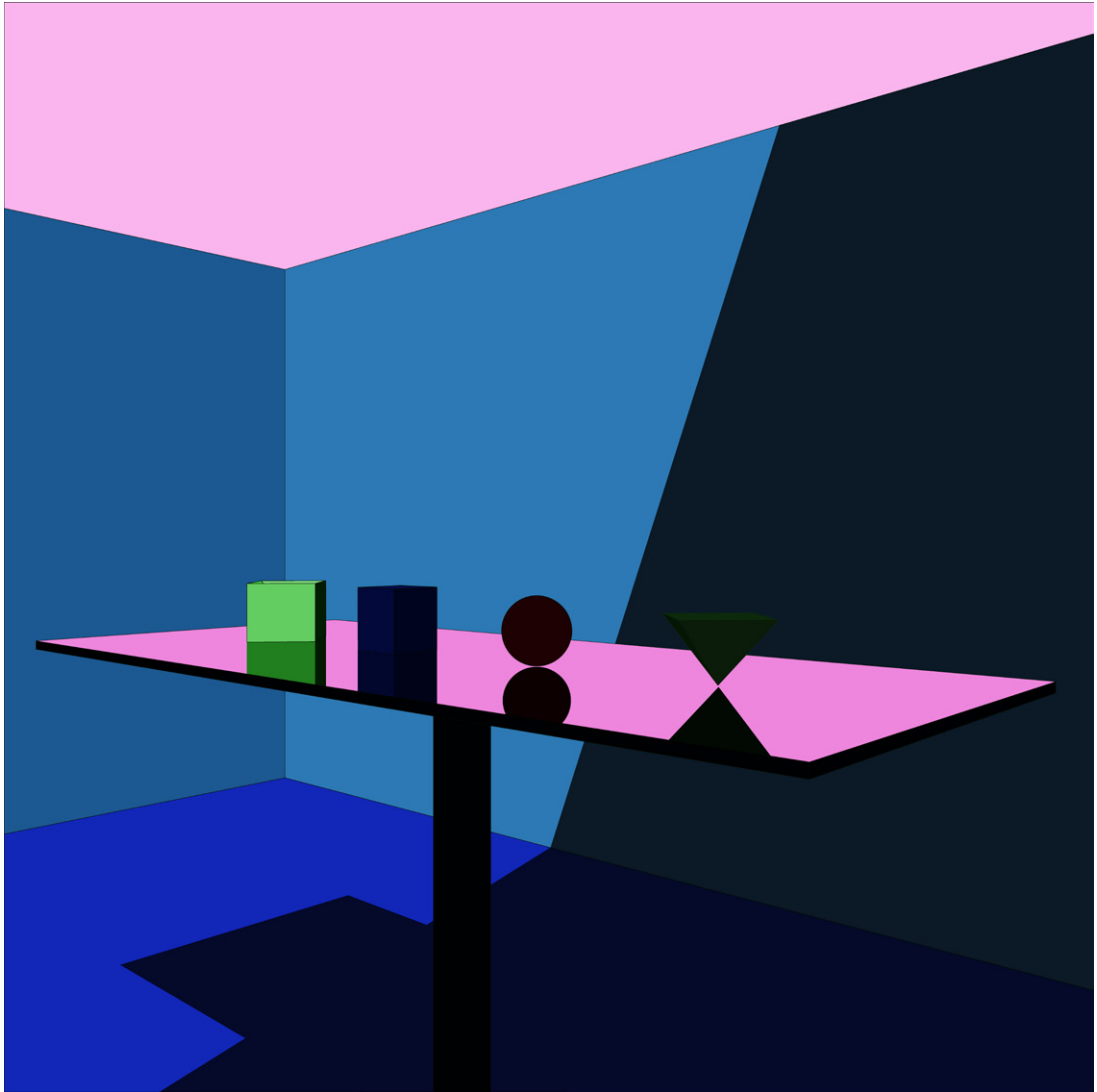

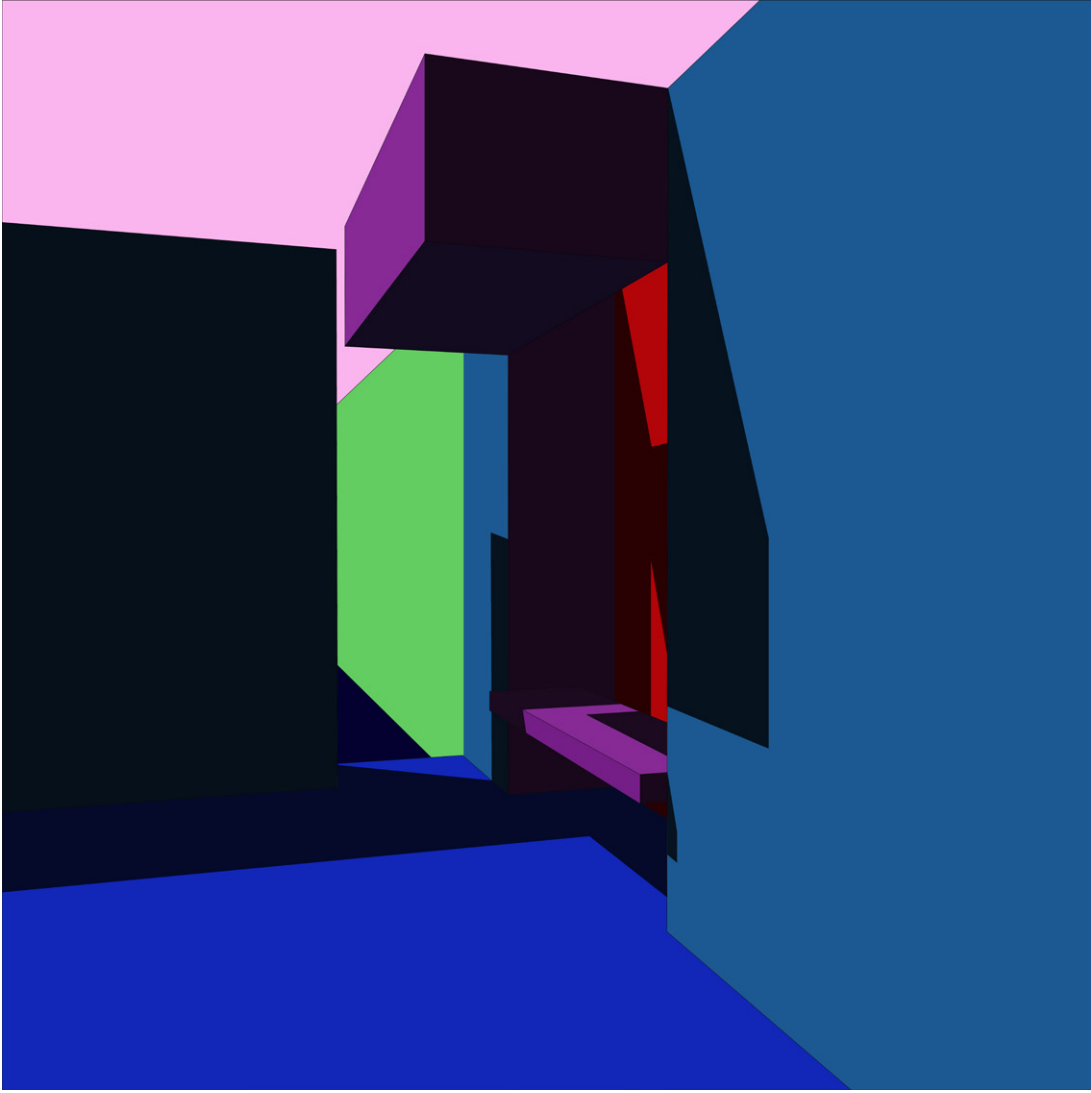

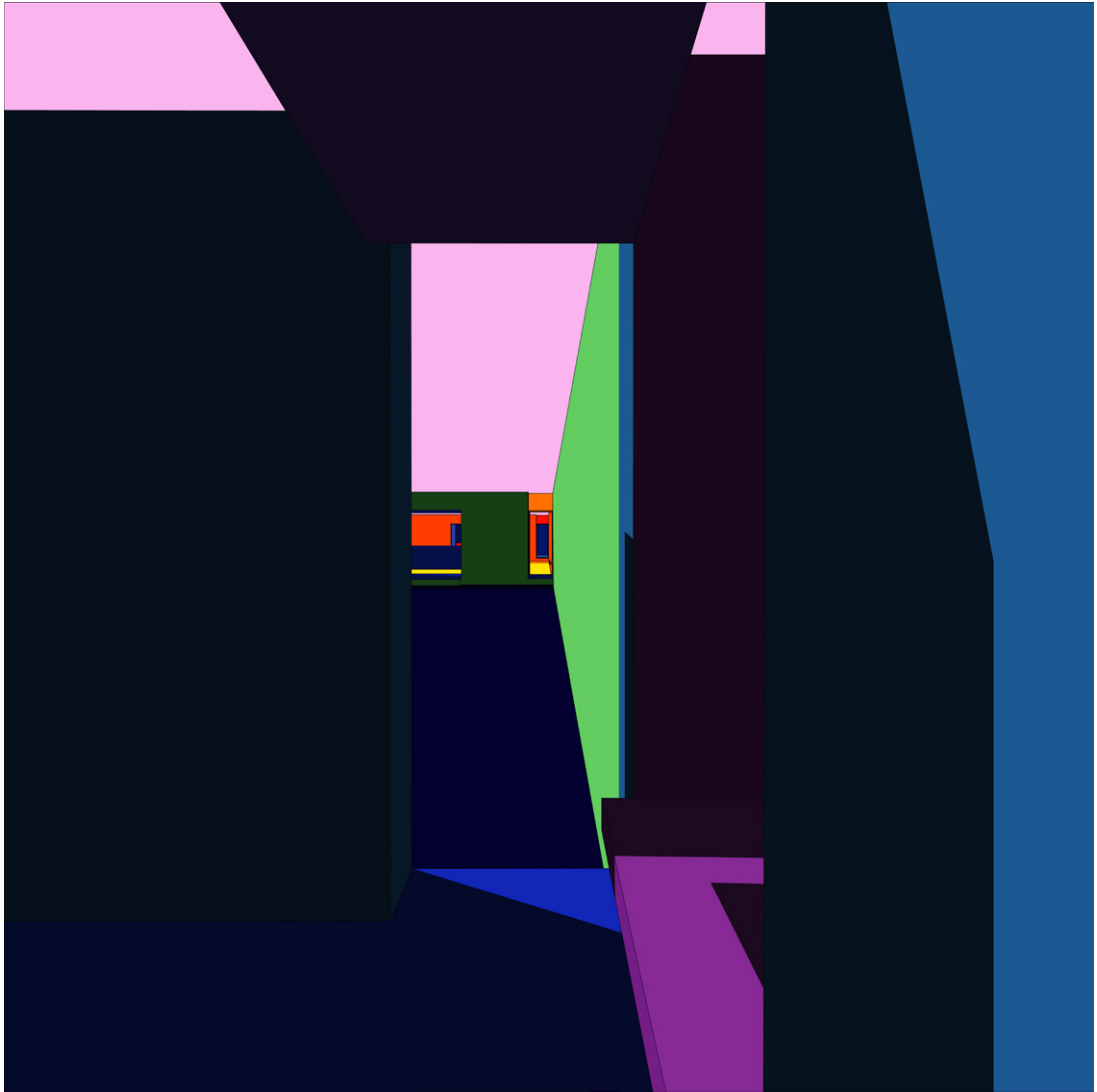

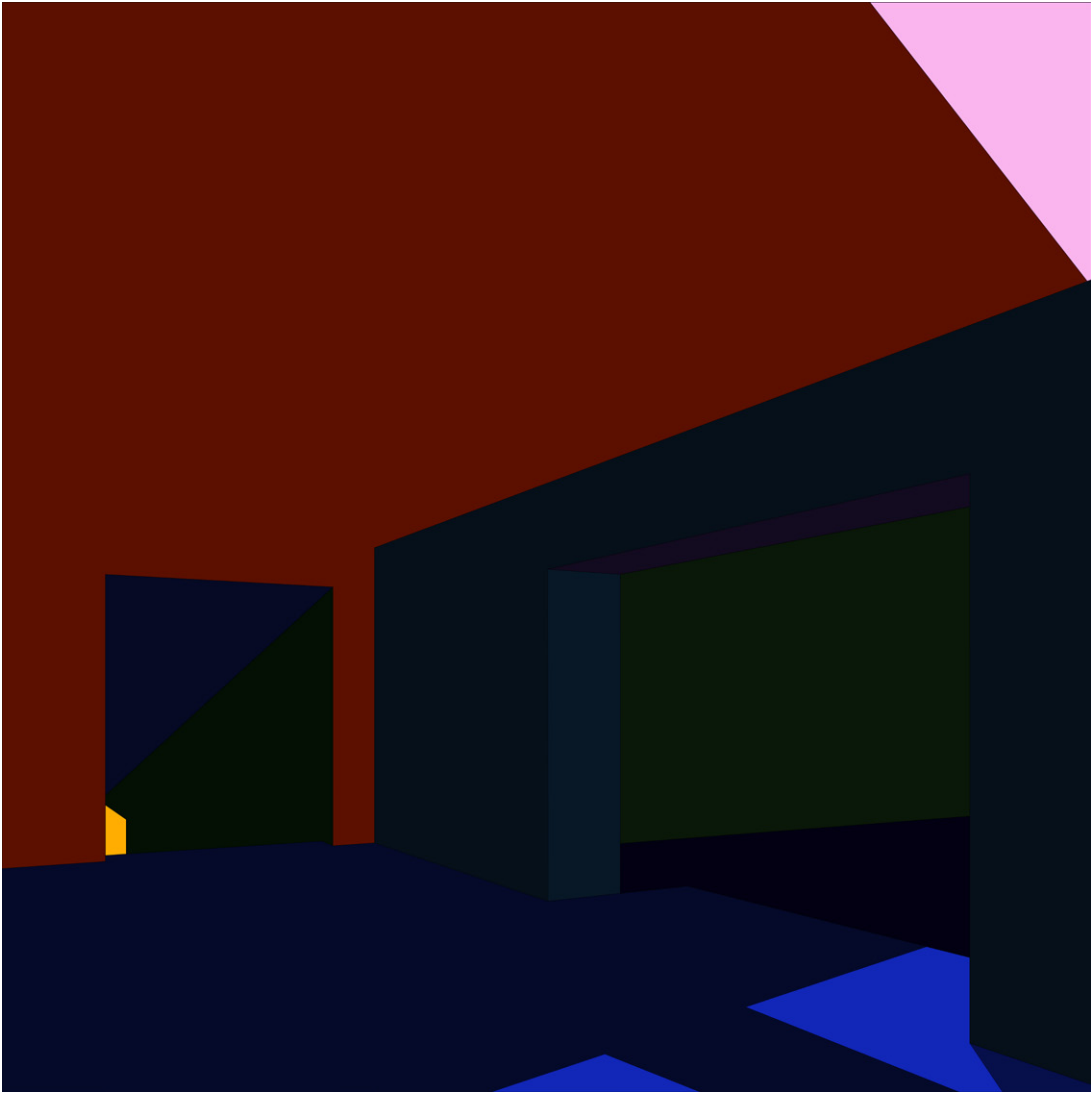



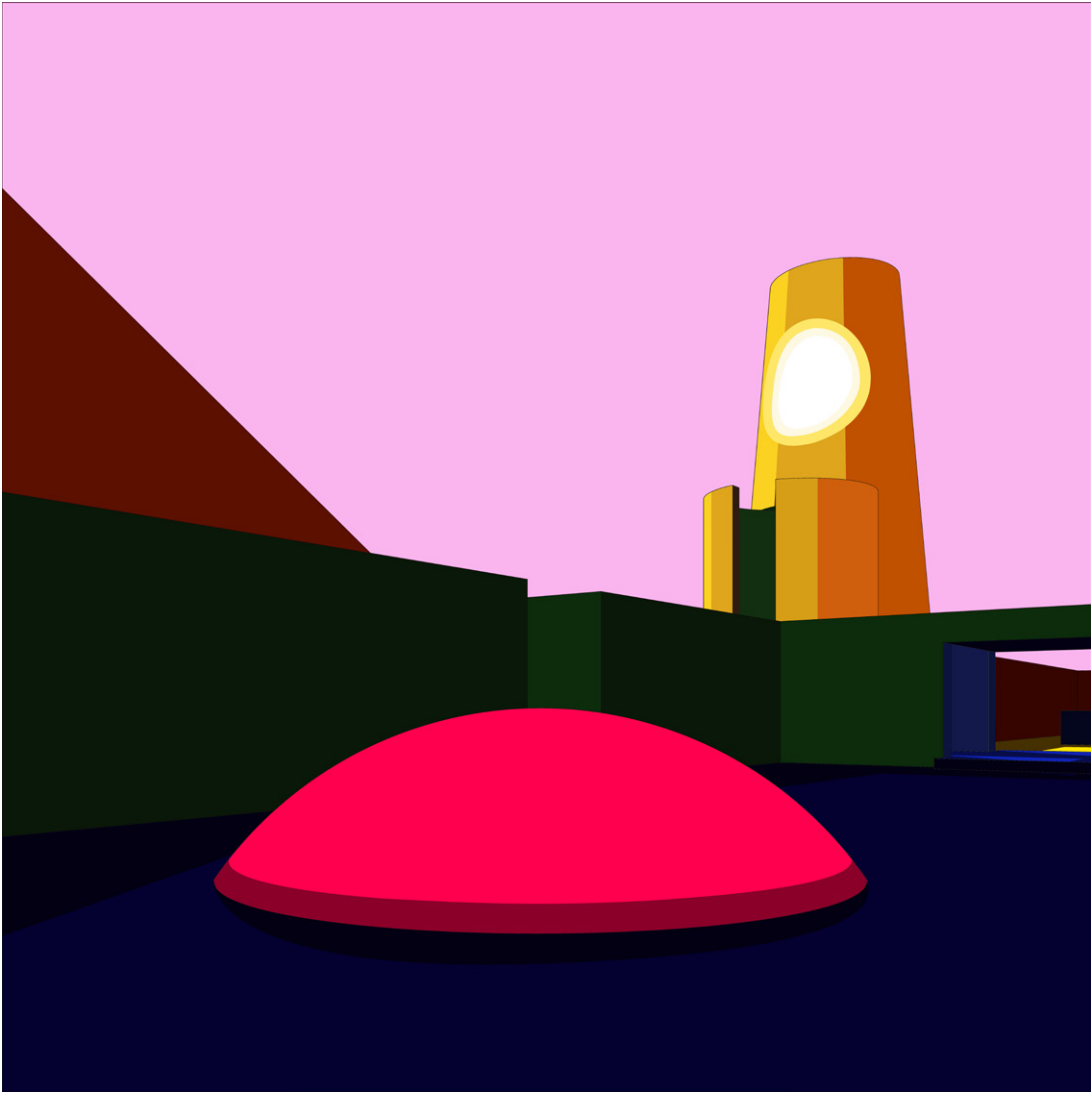

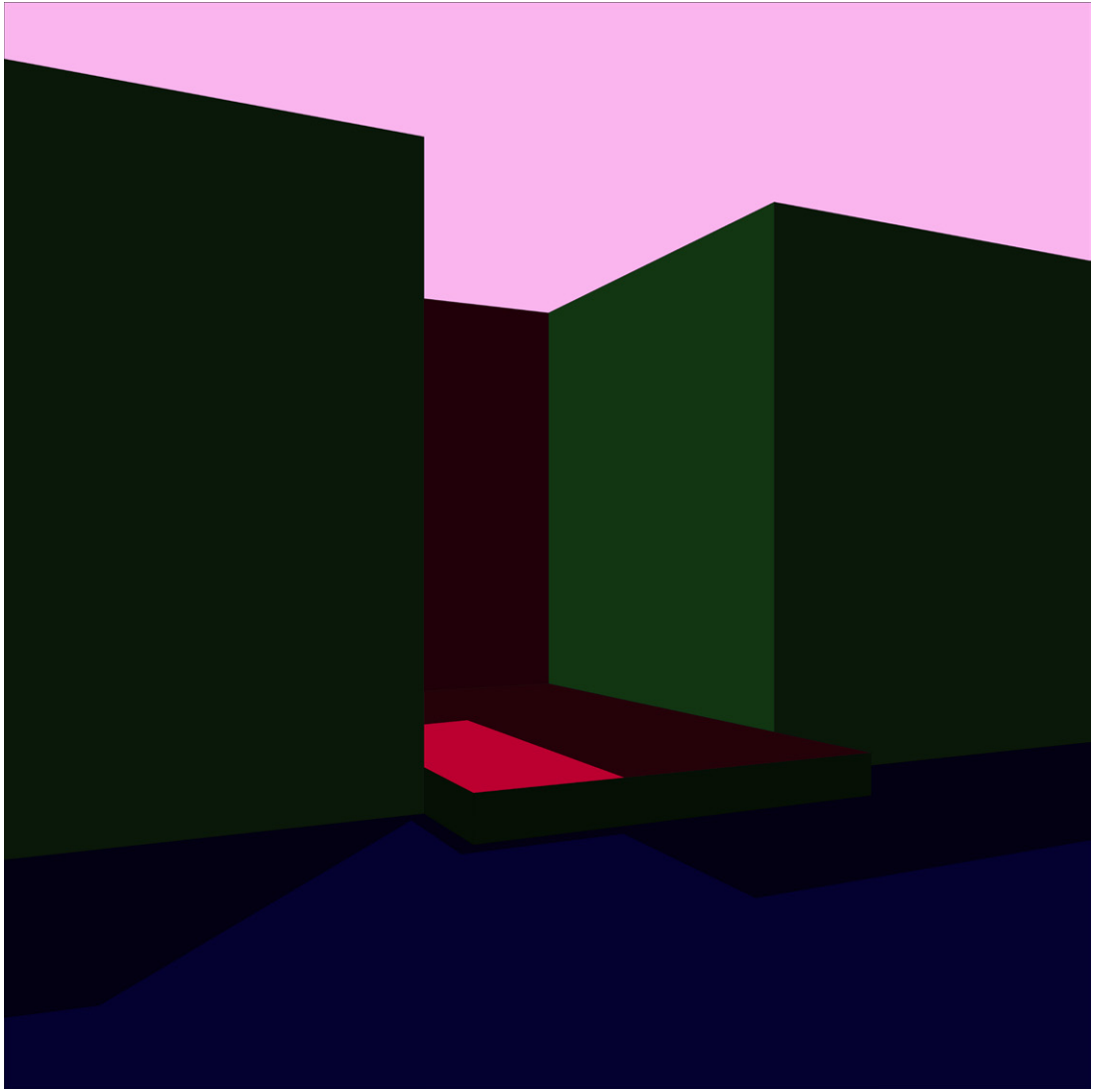

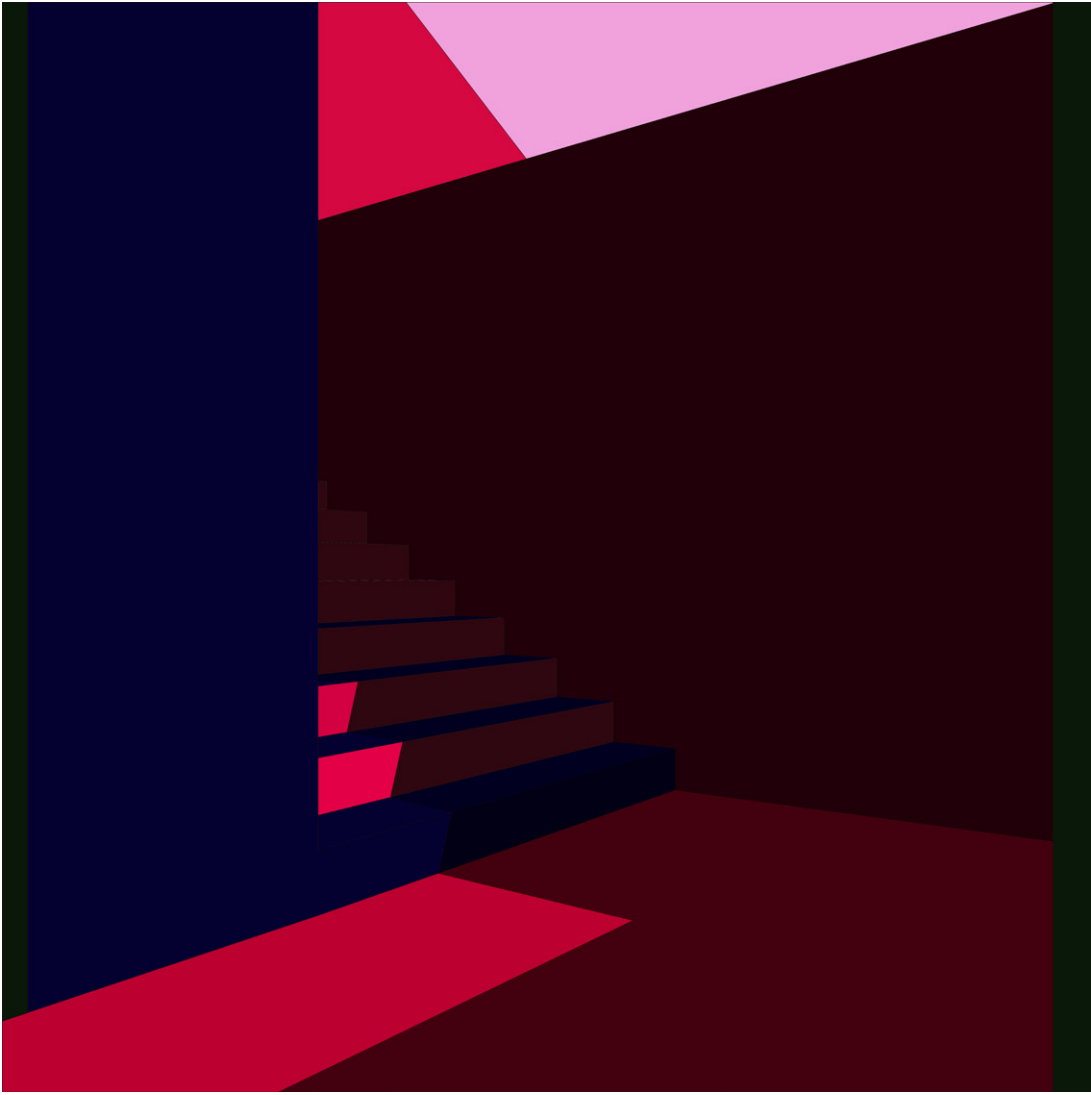

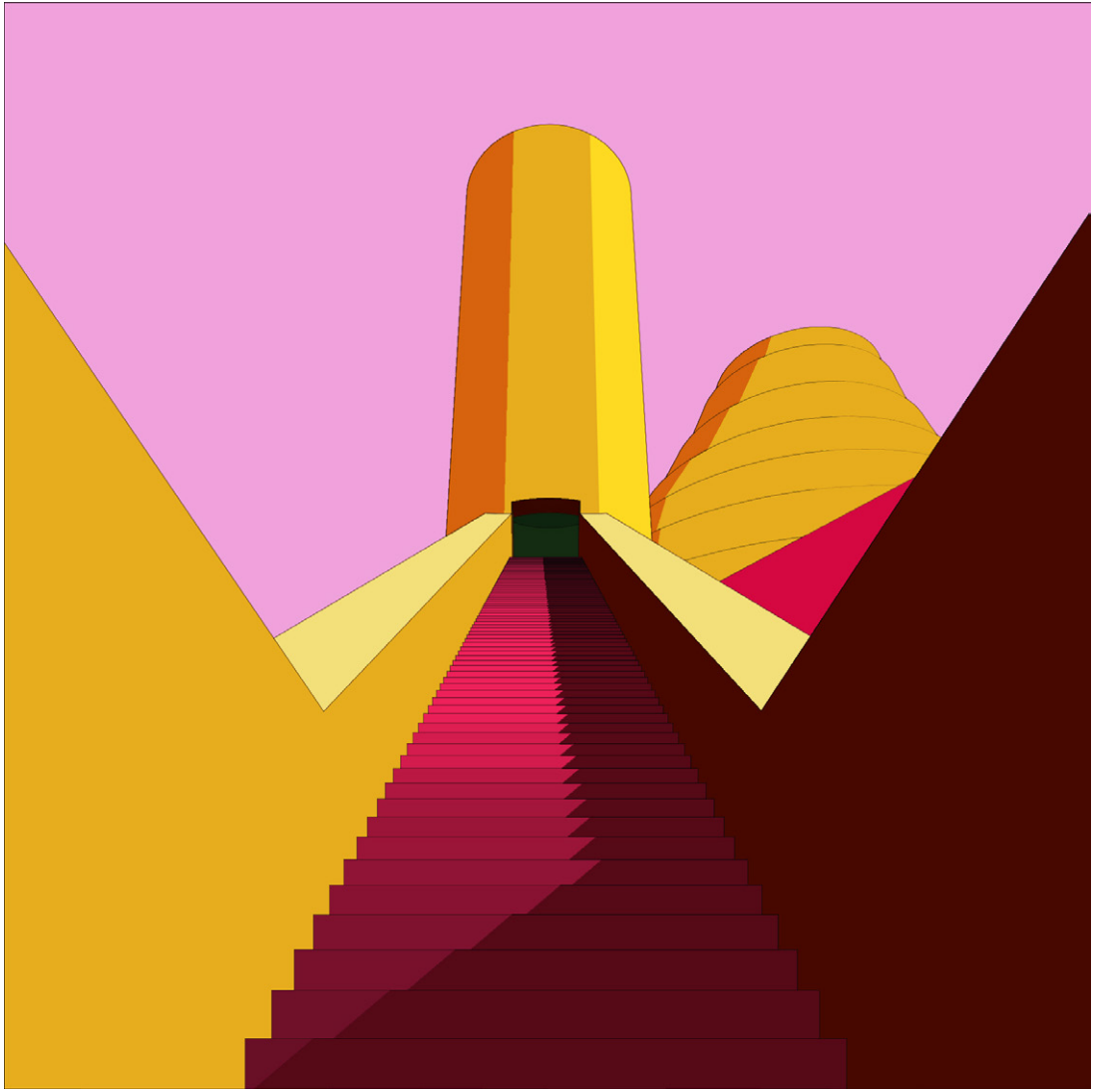

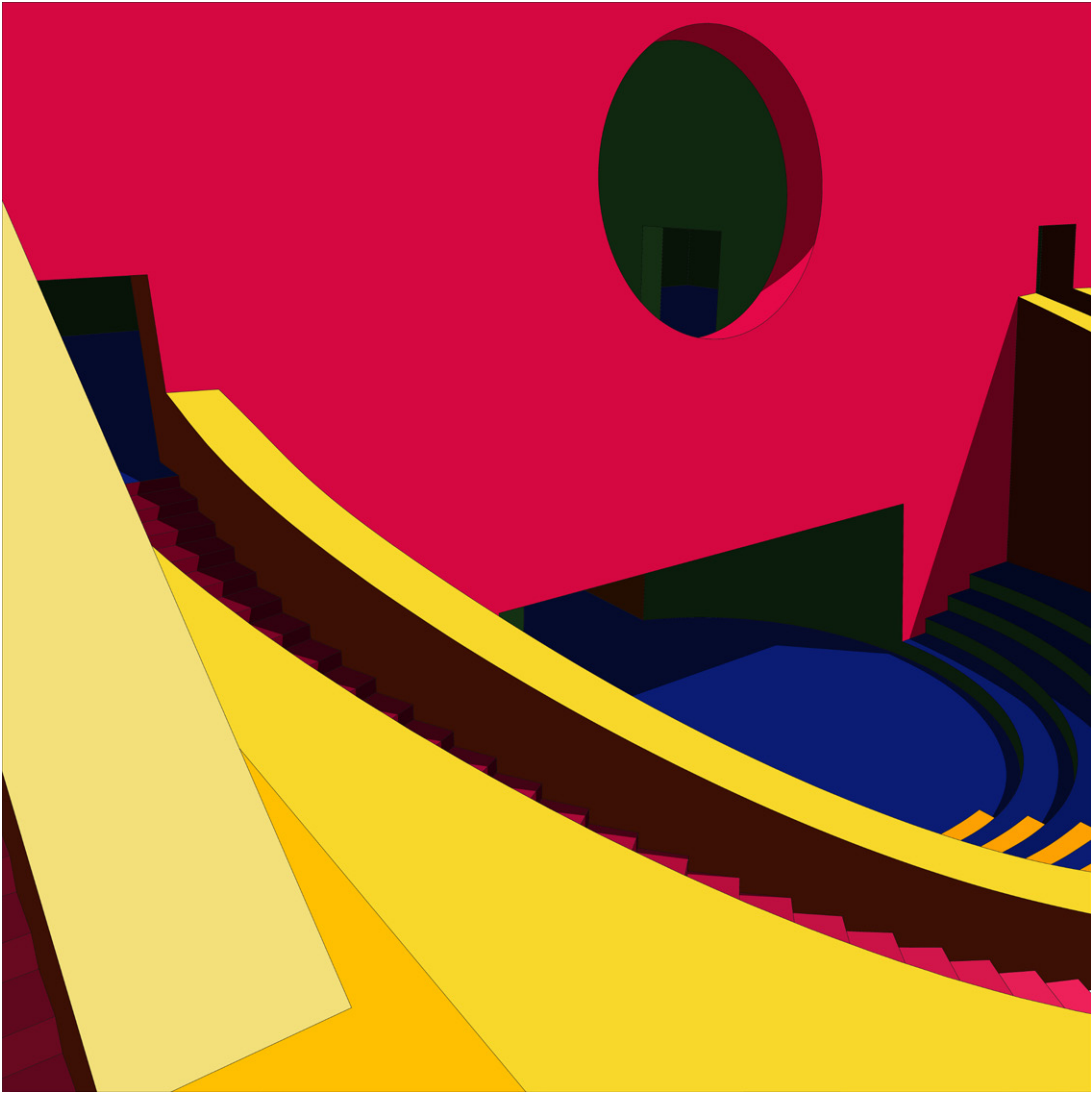

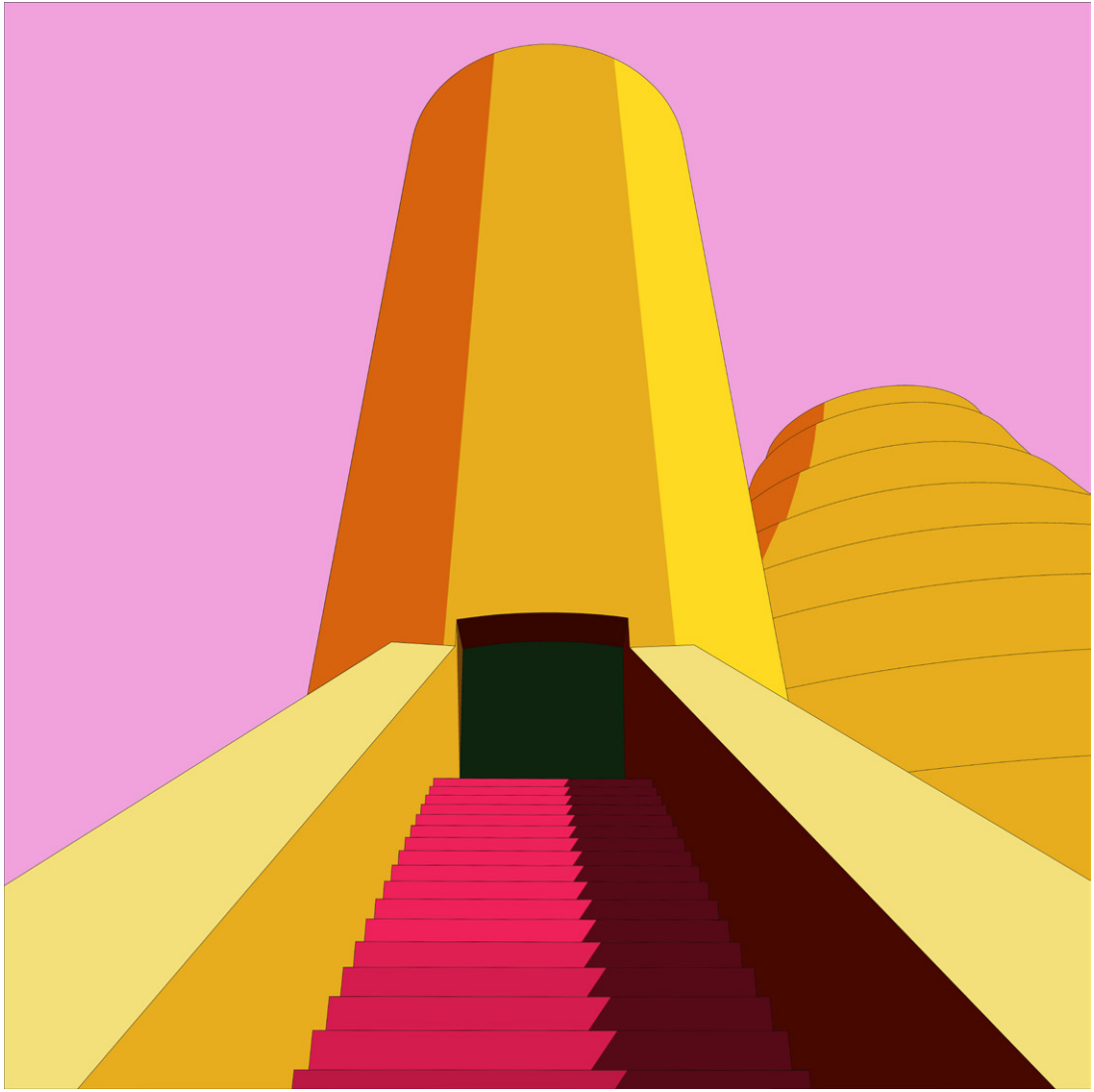

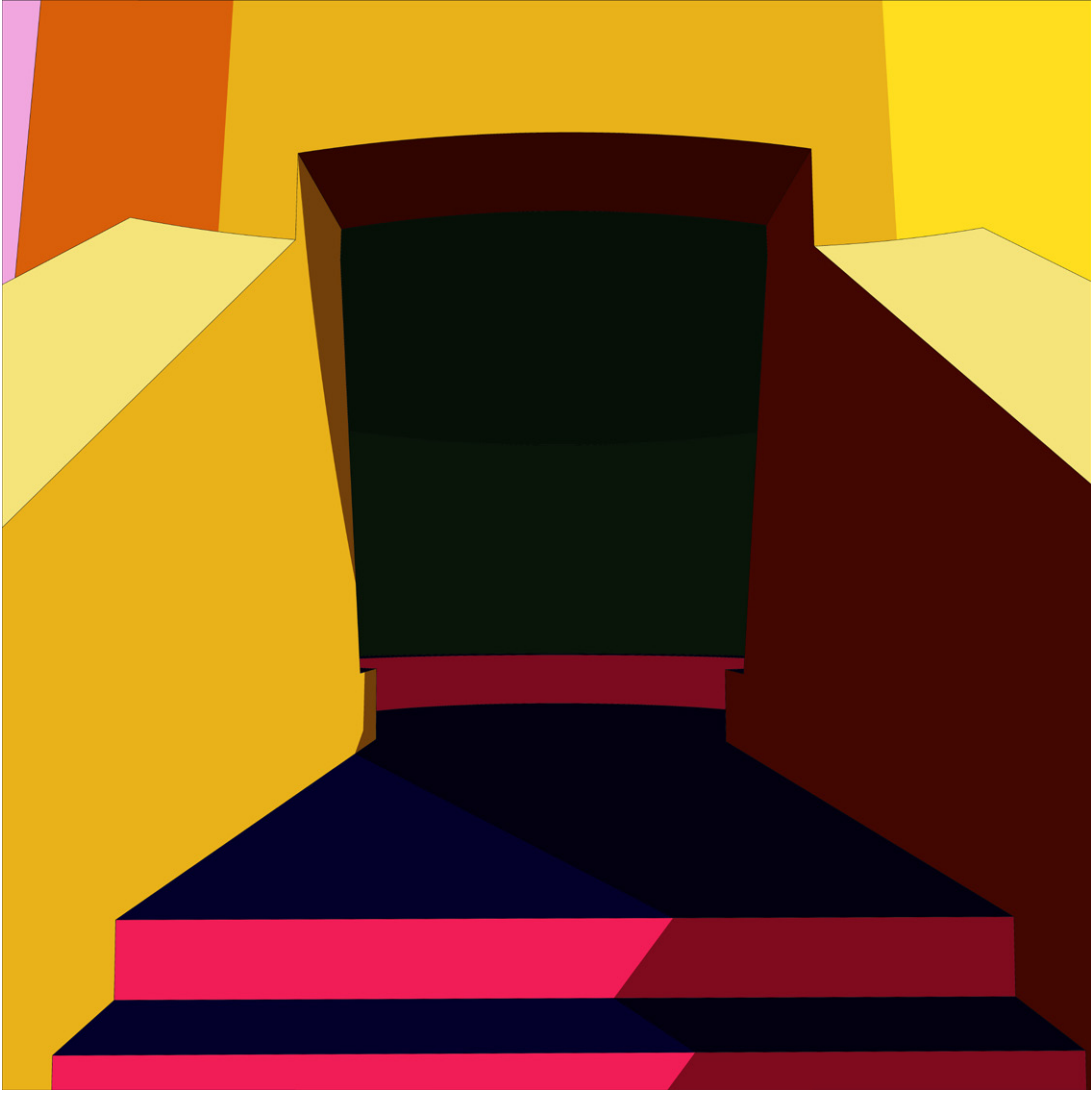



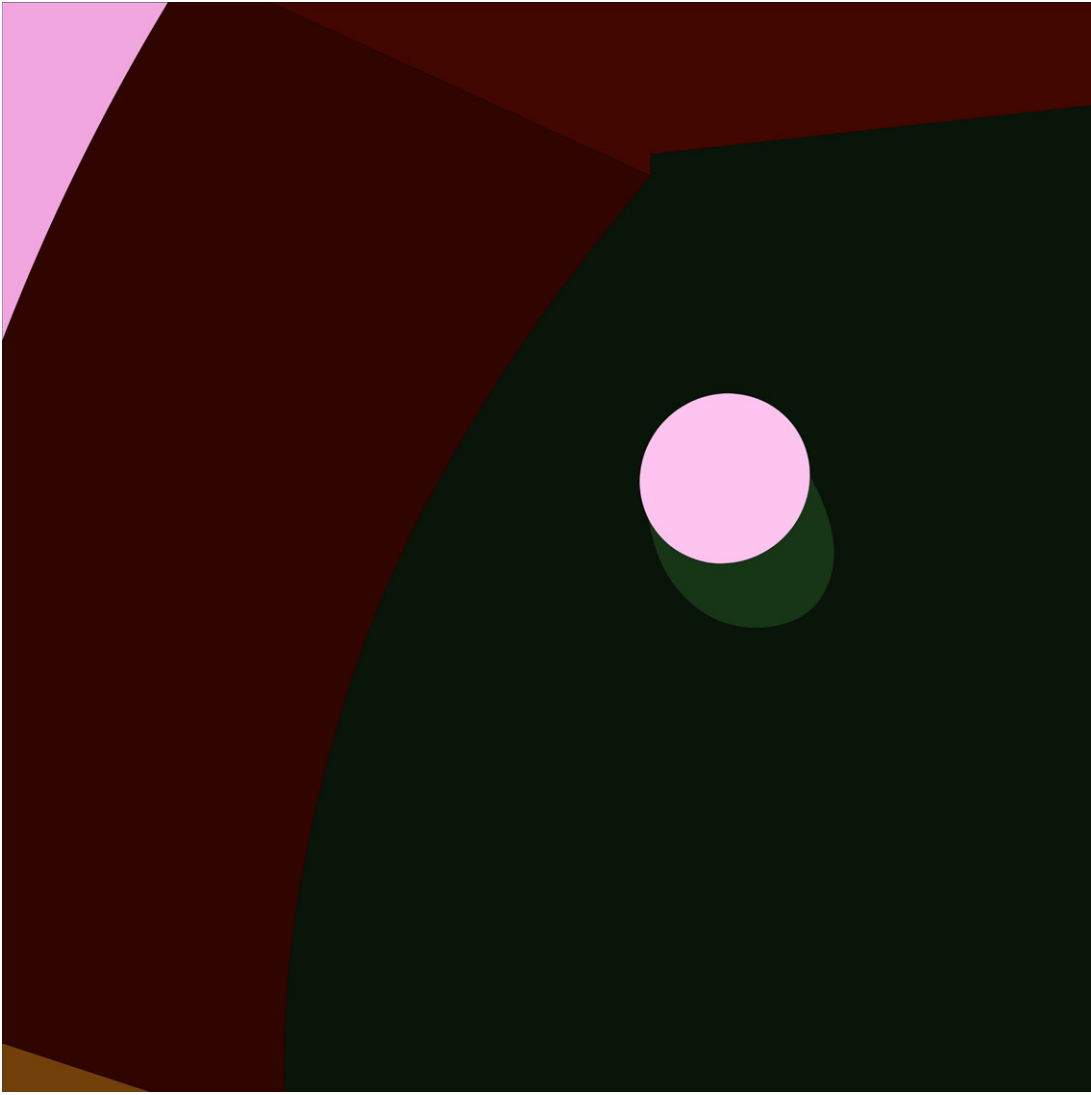

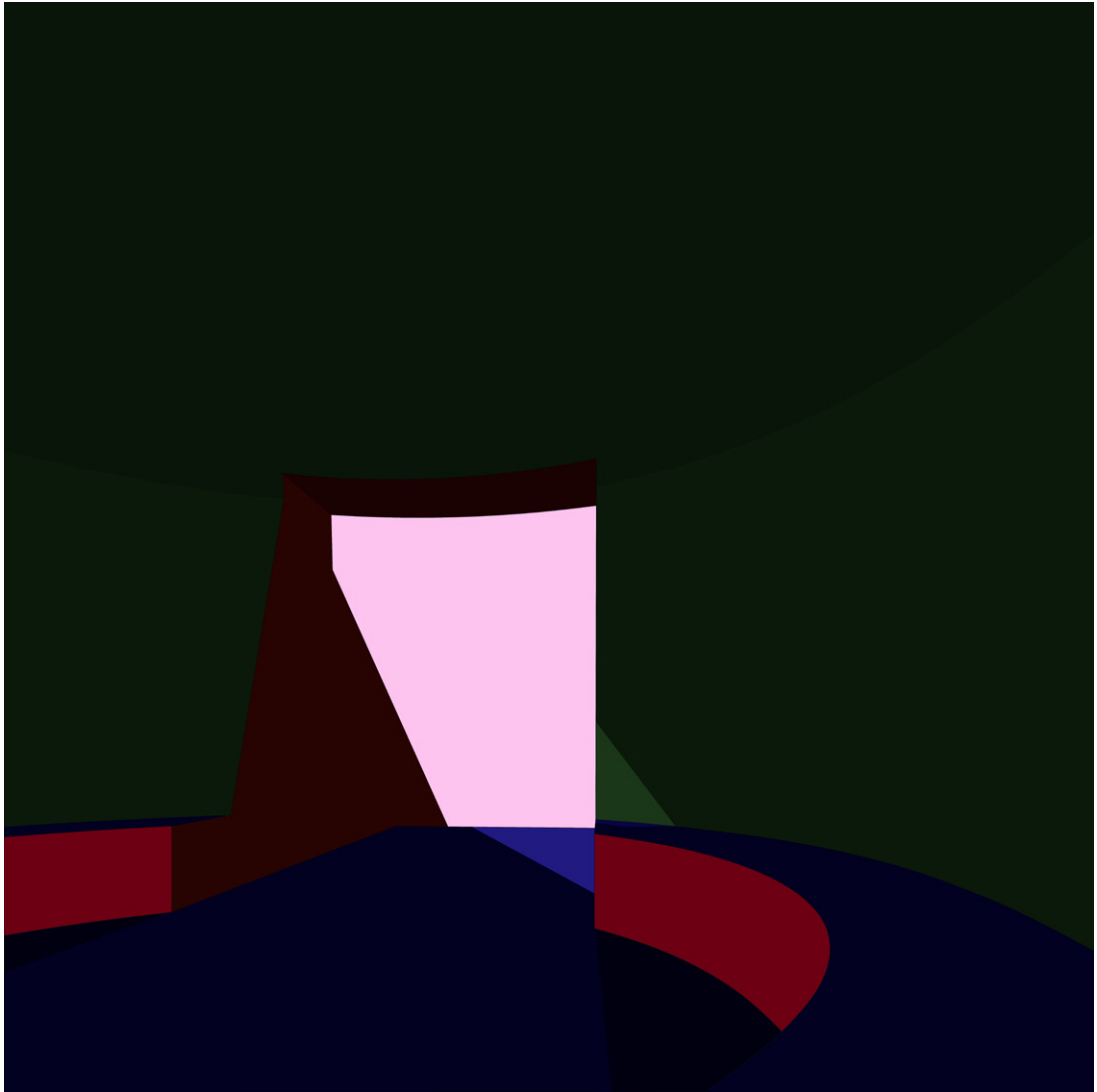

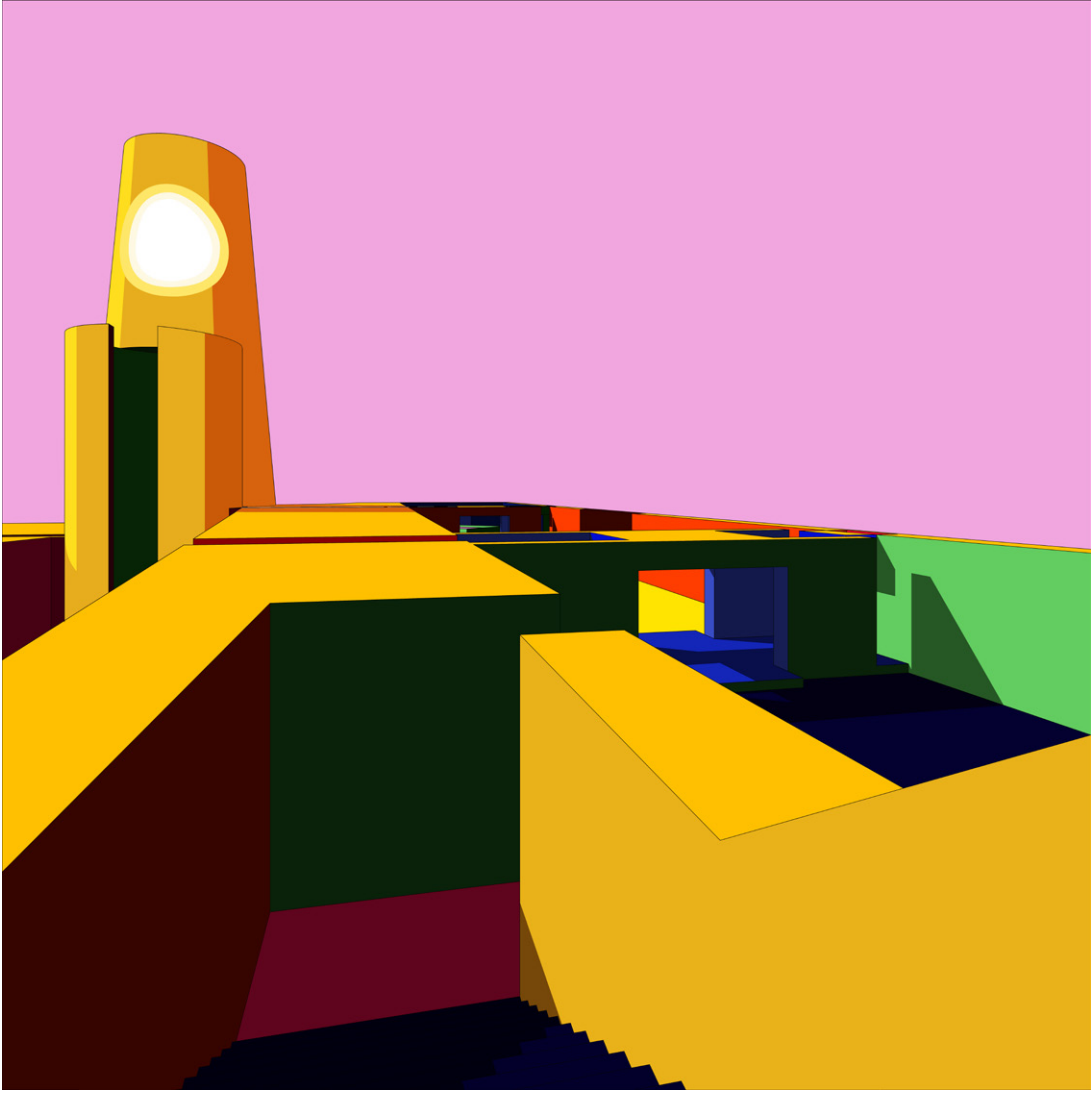

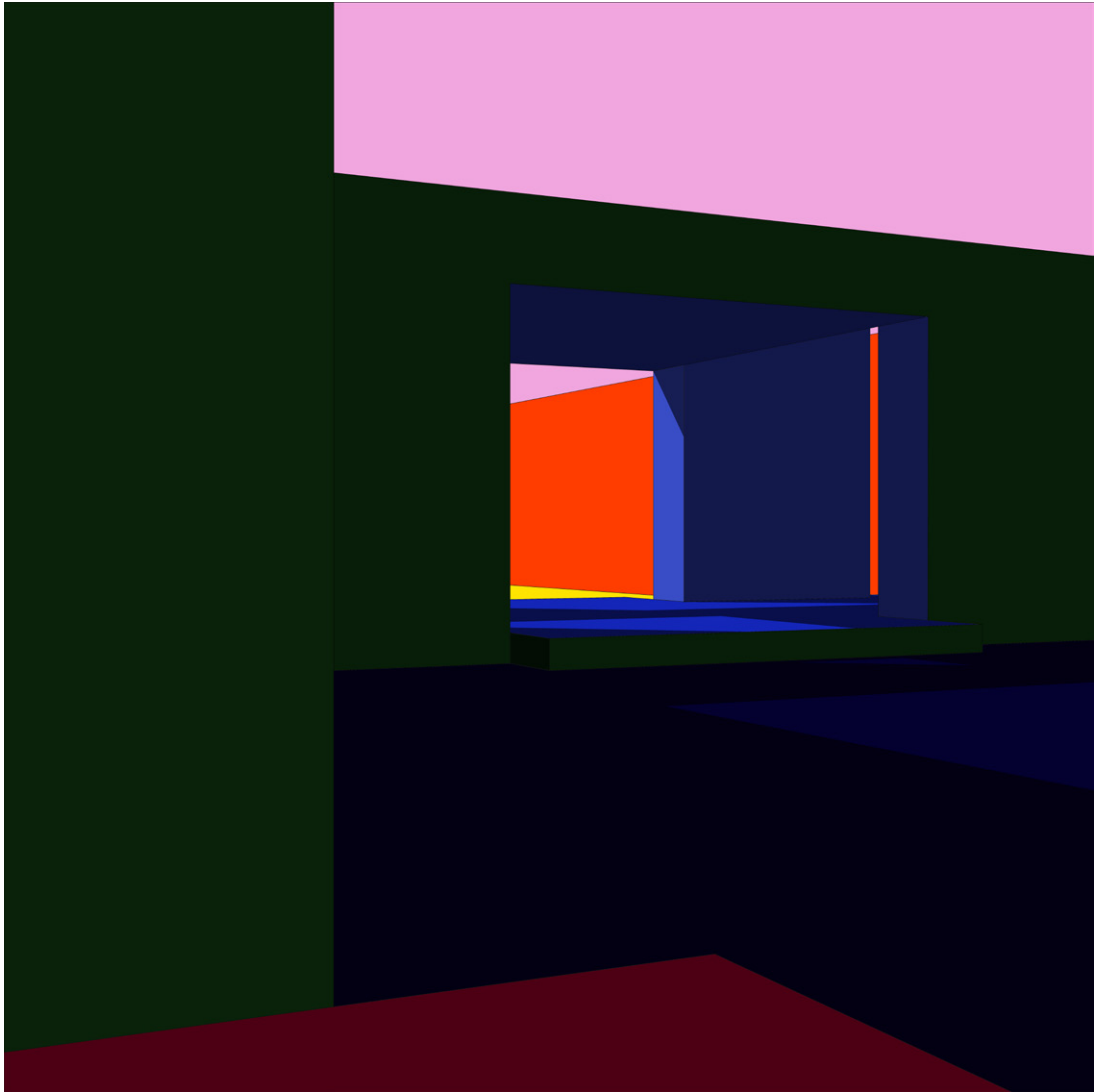

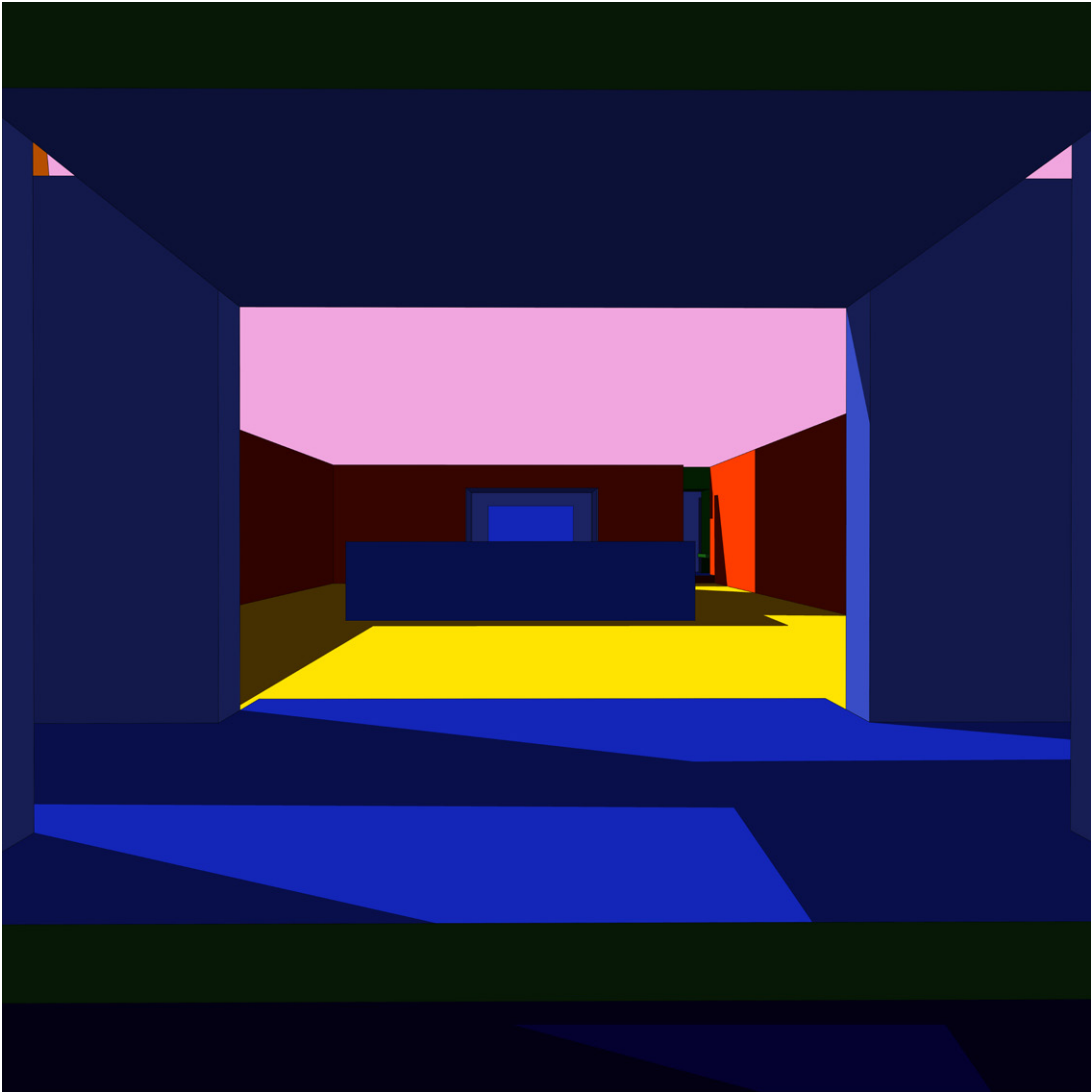

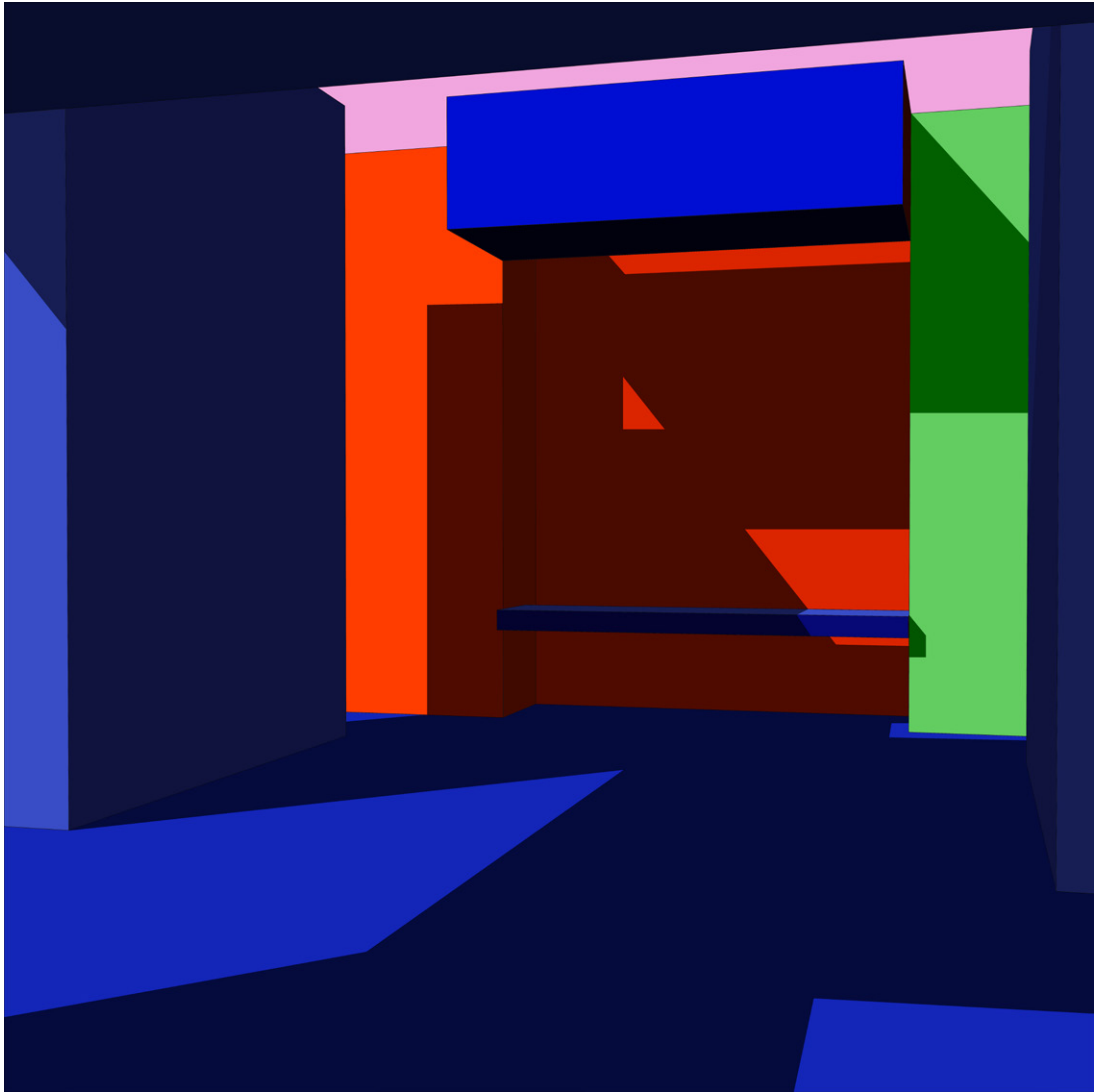

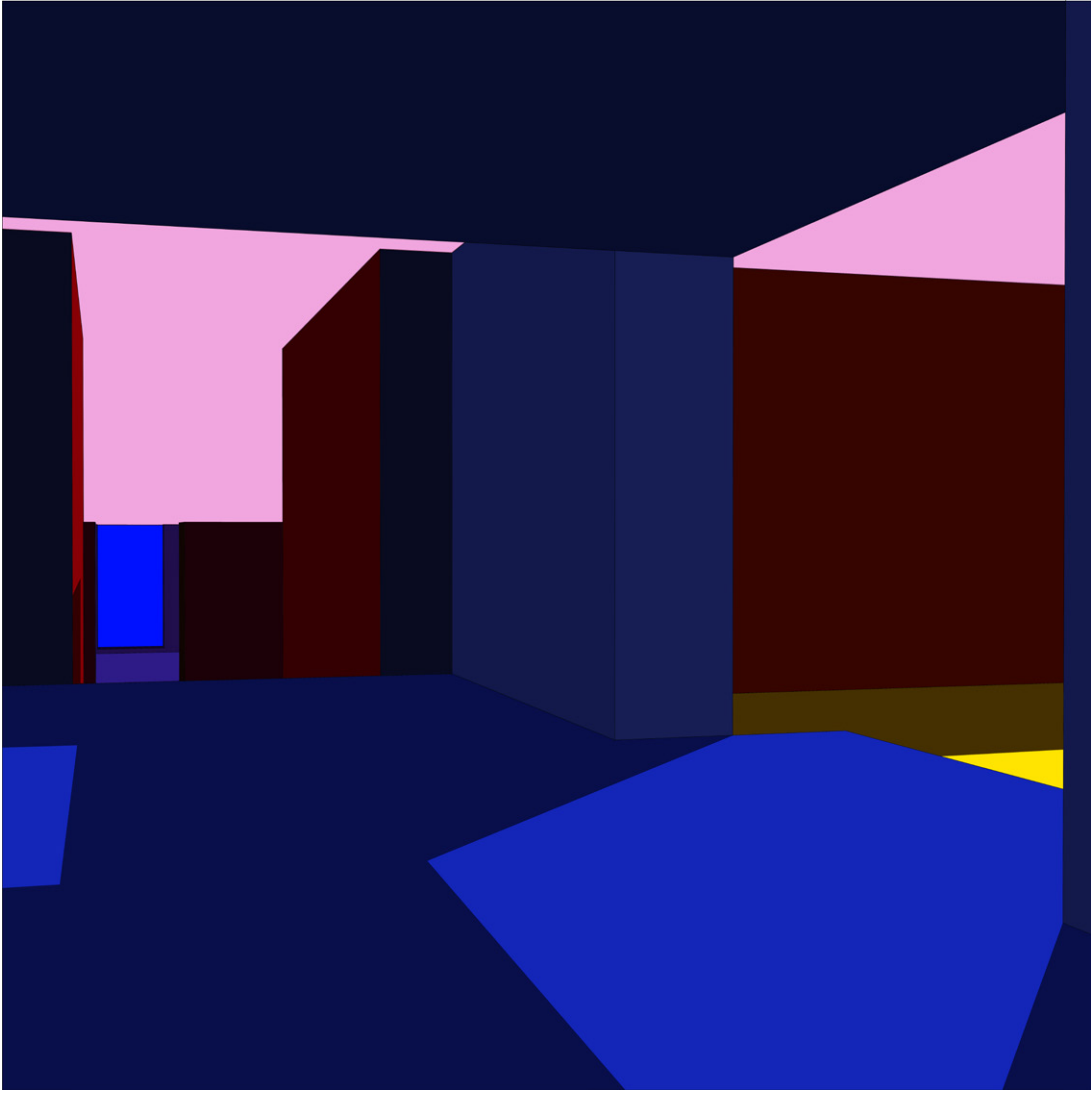

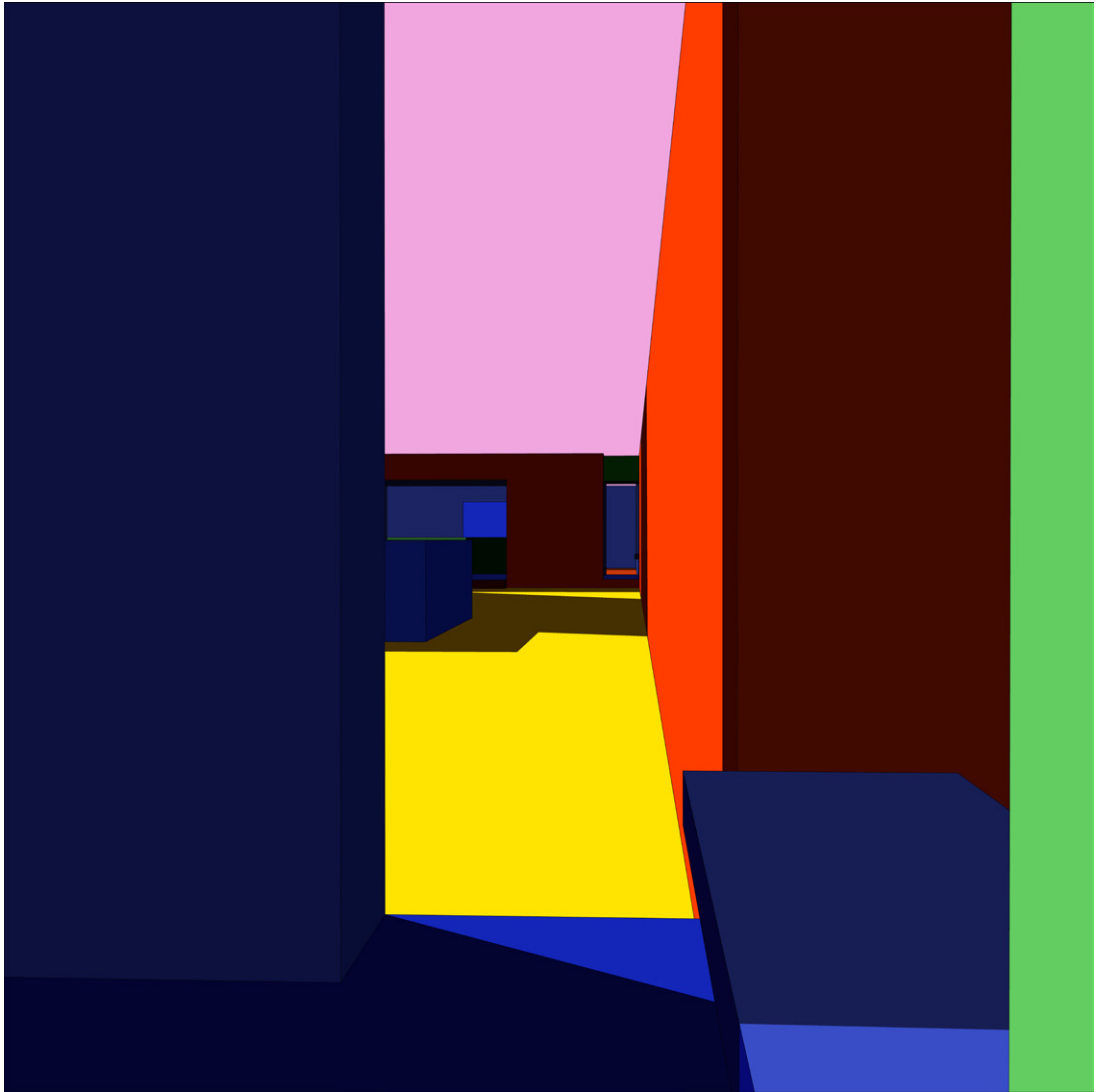

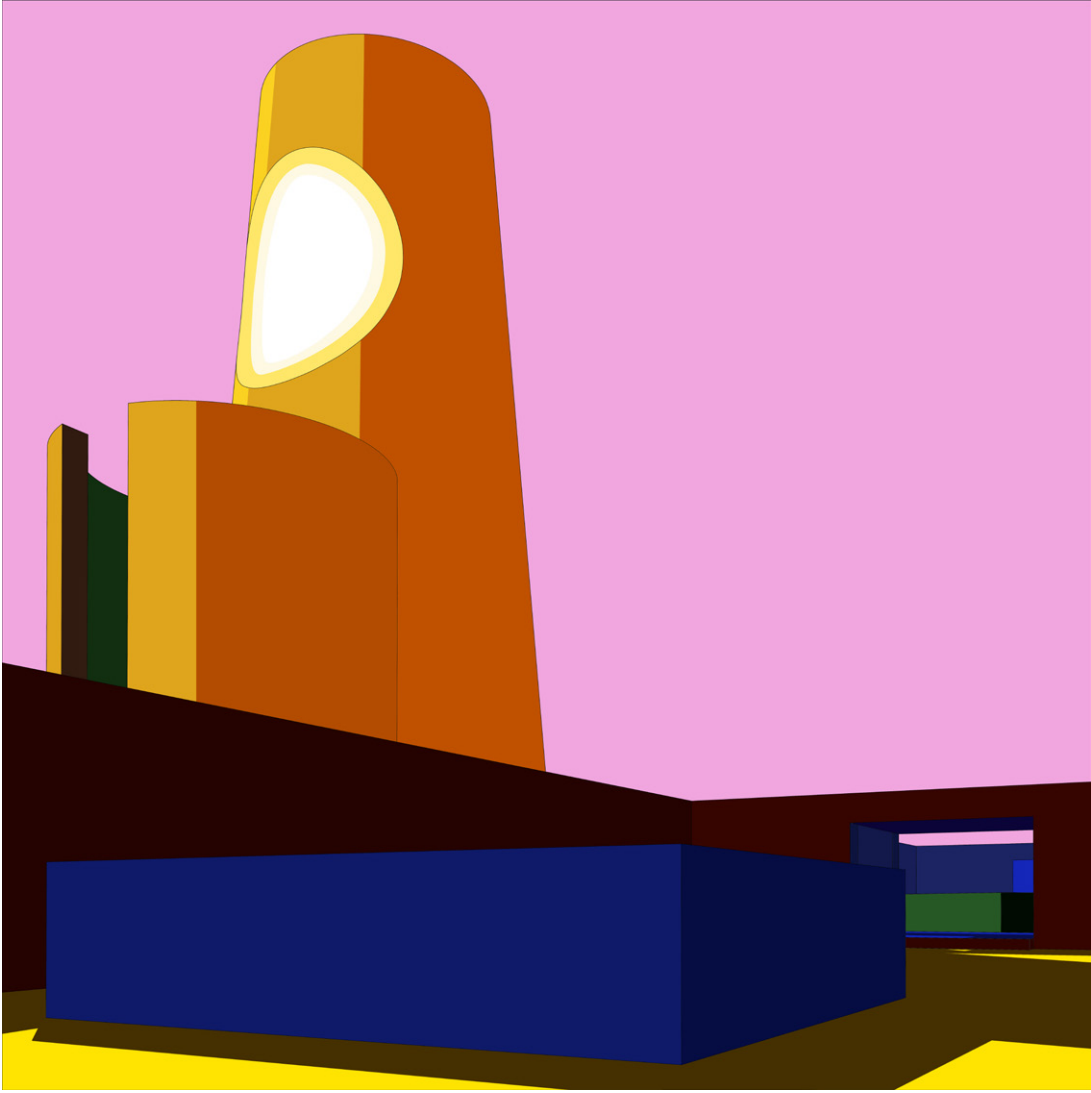



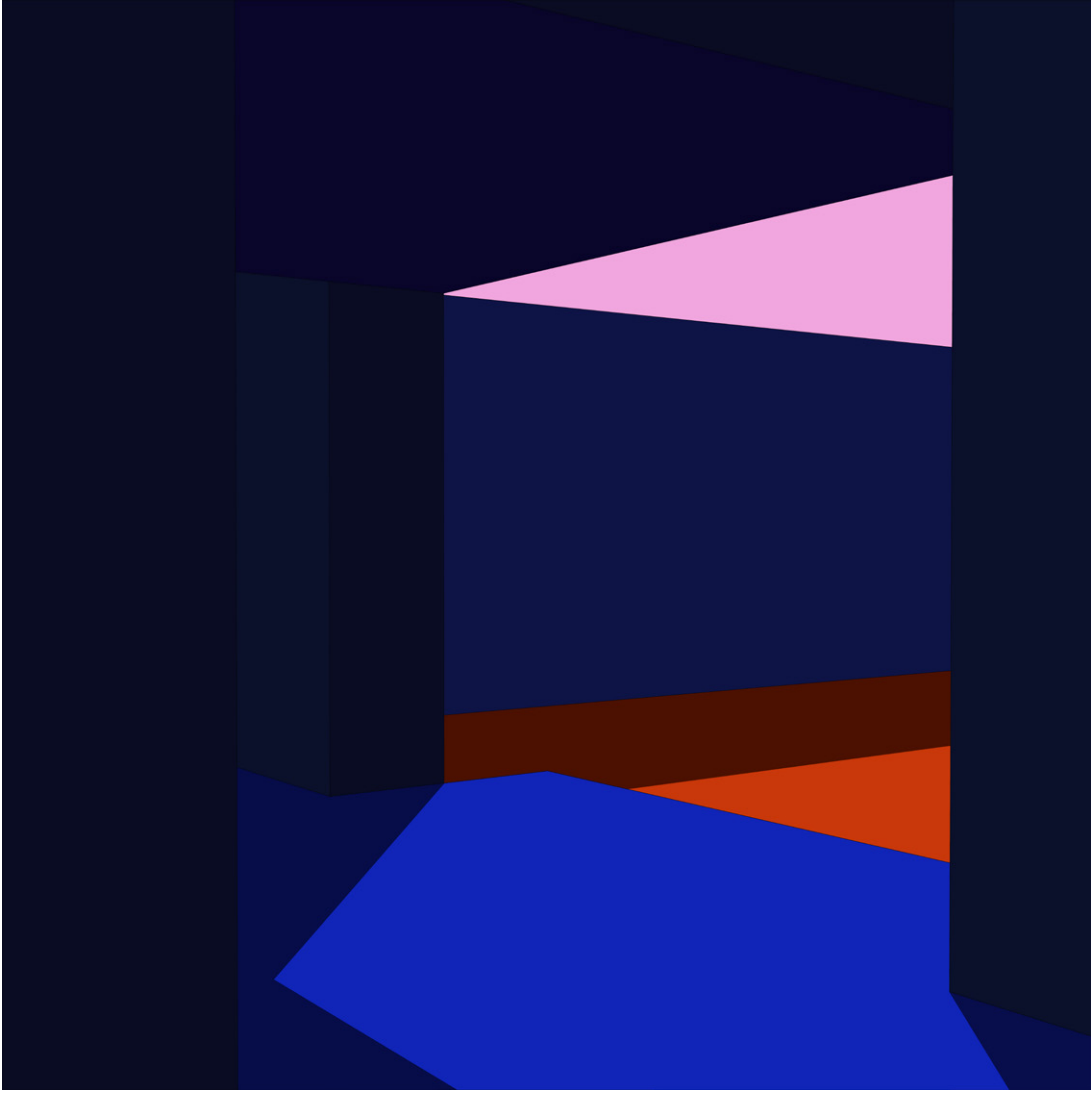



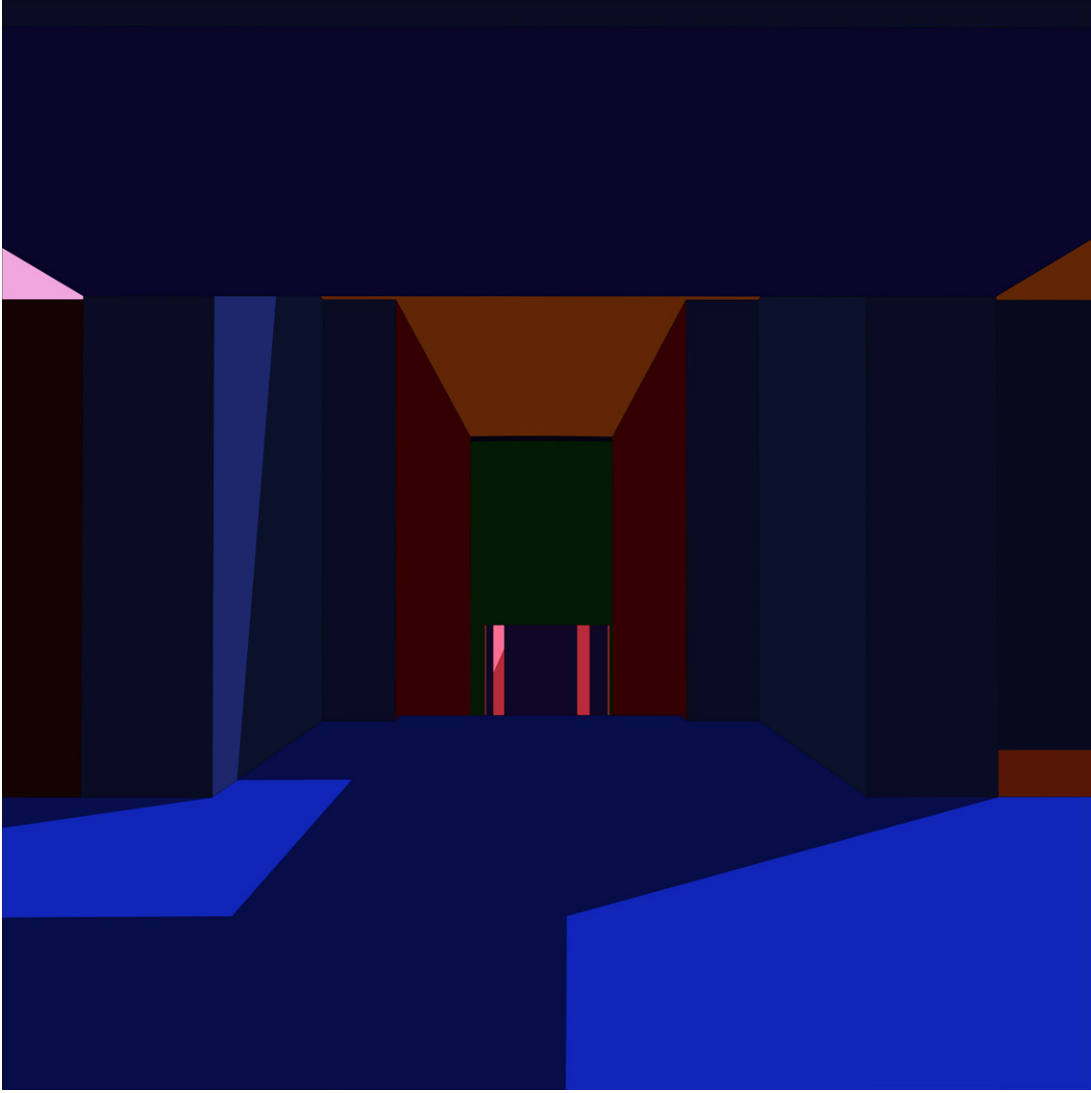

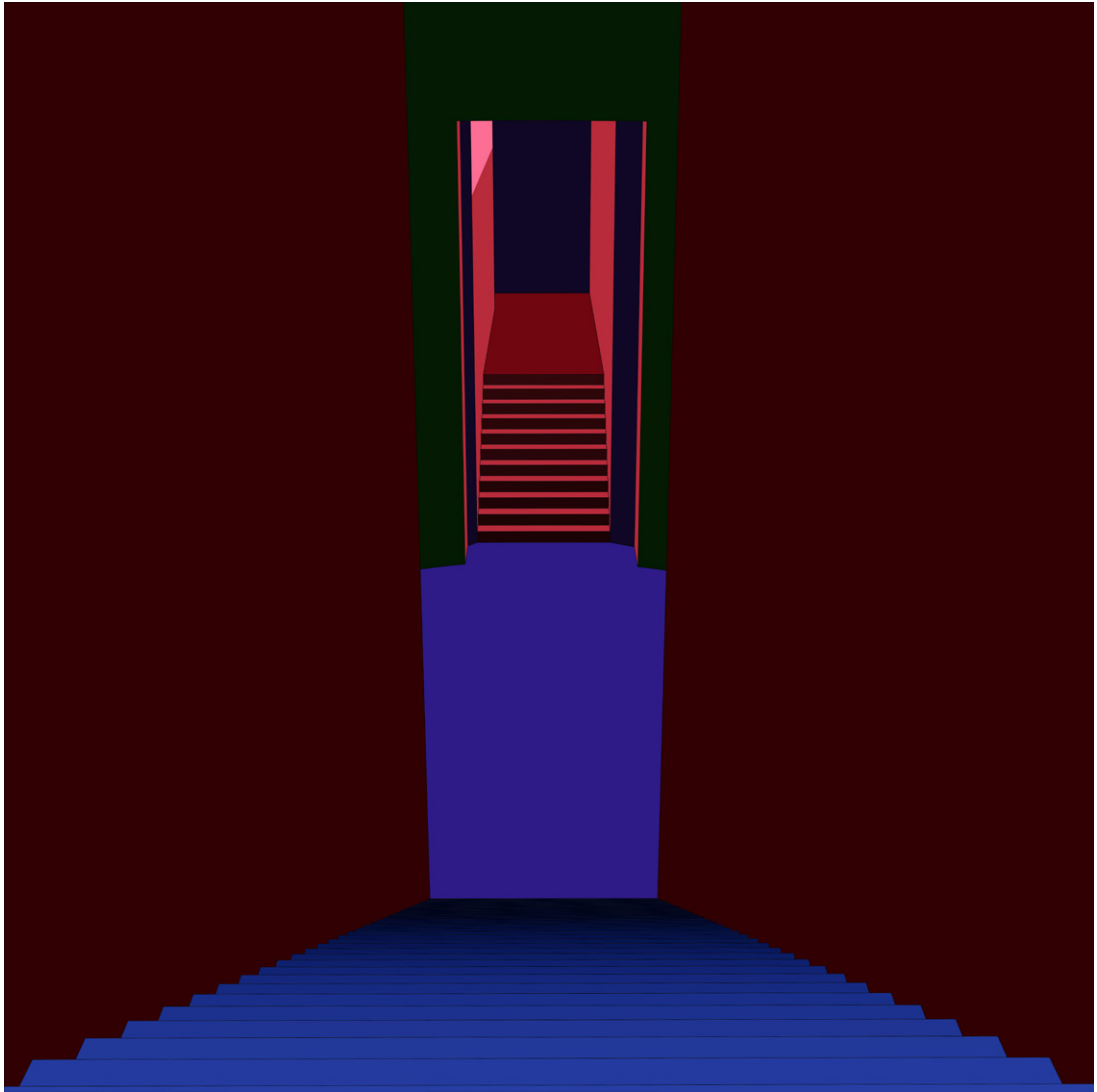

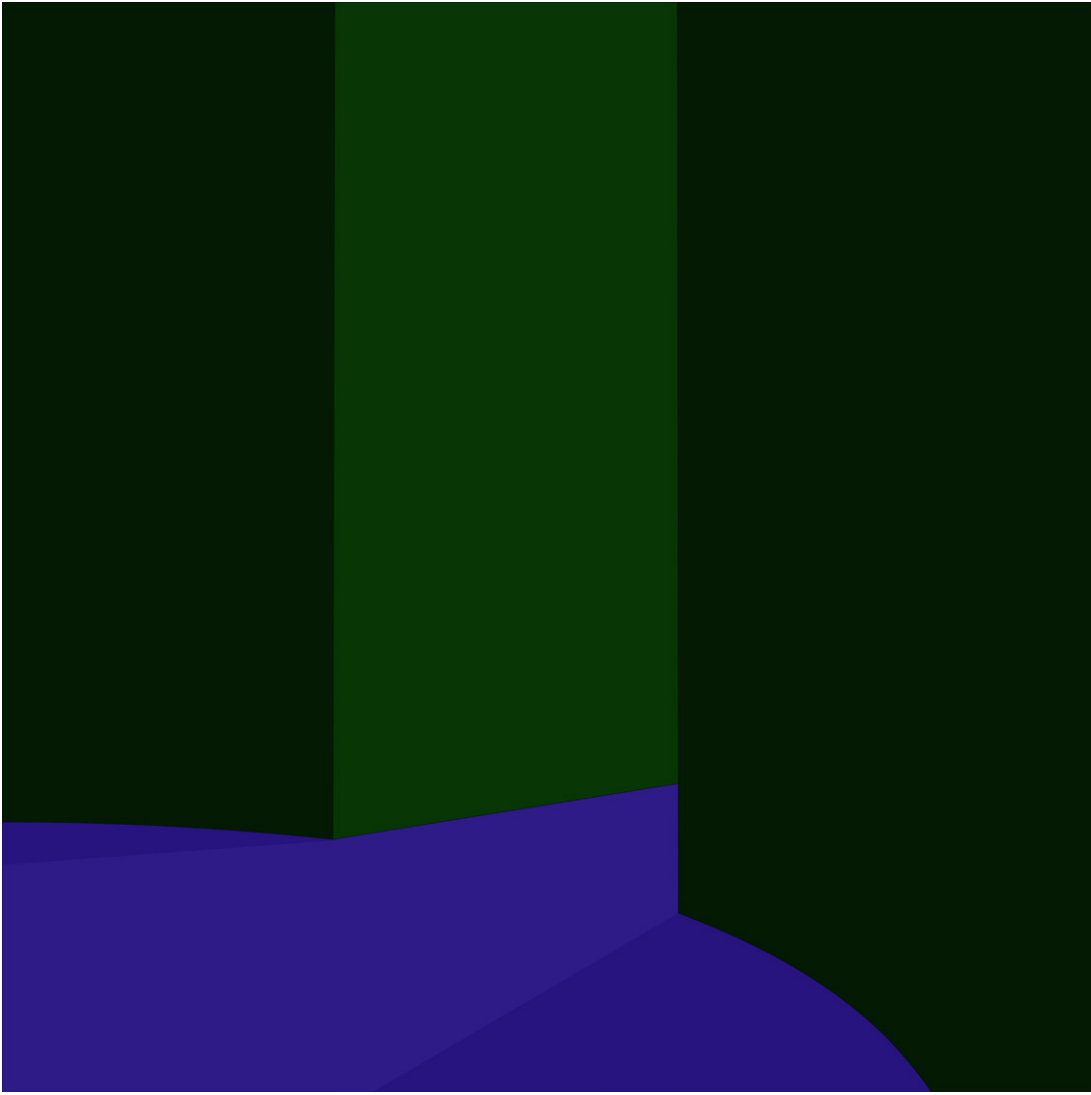

Drawings

The drawings (plans and sections) that are presented on the following pages (221-234) were produced as representations, based on the sequential perspective drawings created in this project. This stands in contrast to what we might call “the traditional way of working”, where one starts a design working in plans and sections and then later, when a design has emerged, constructs perspective representations of the proposed design based on those plans and sections. Here the approach is the opposite: plans and sections, the more technical and abstract drawings, far removed from the actual experience of a space, follow and are based on the less abstract and more experiential perspective drawings.

Site plan

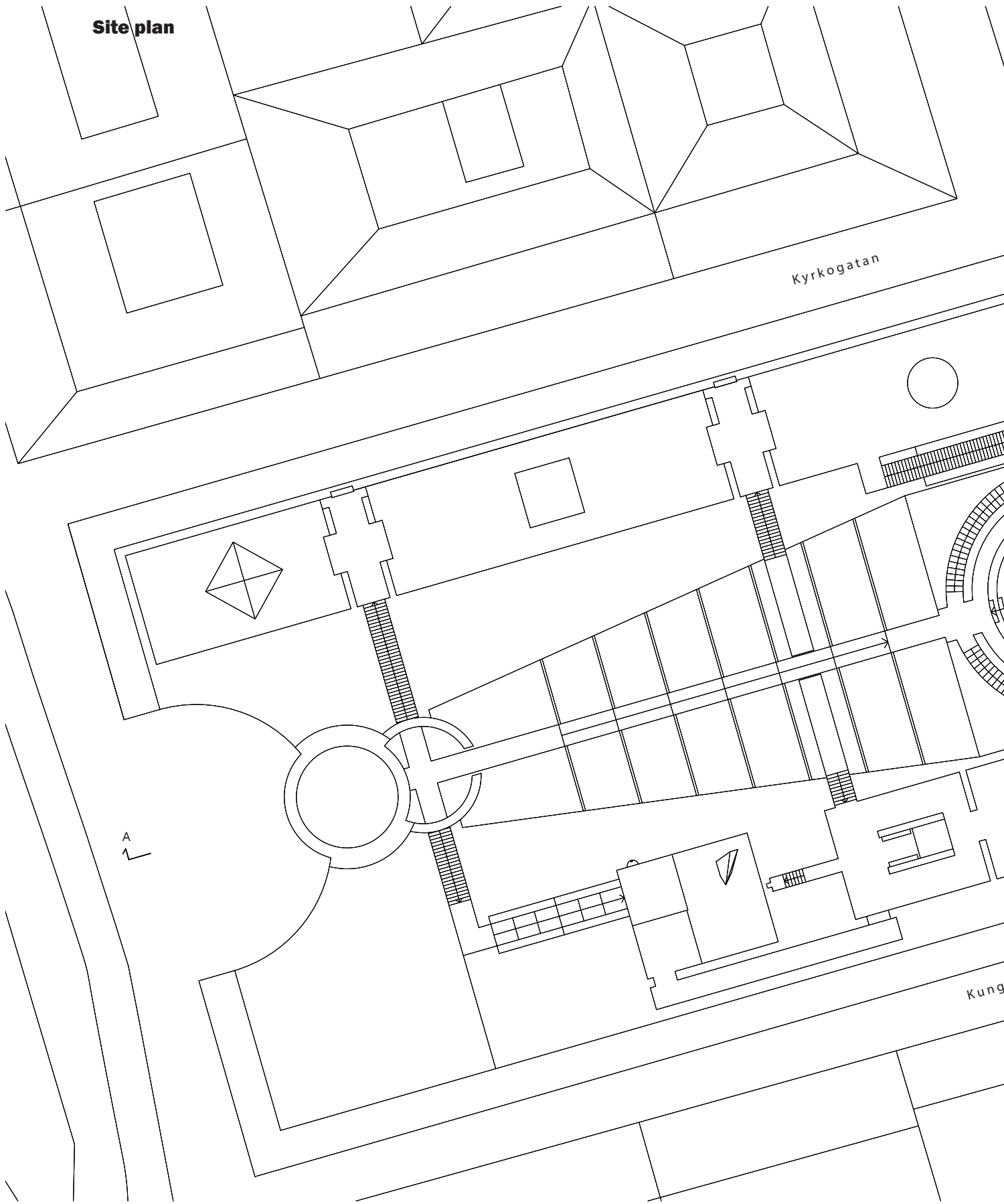

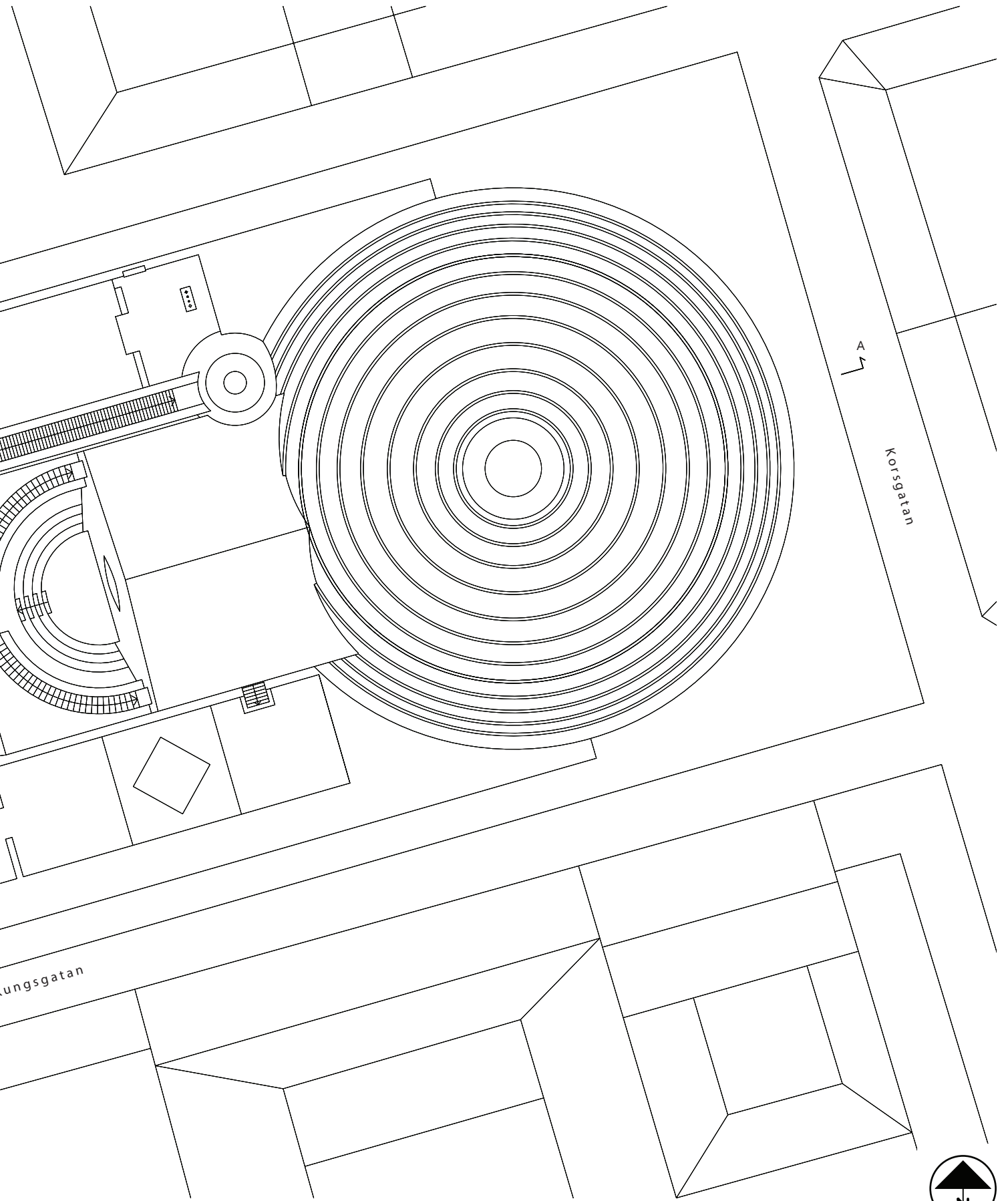

Longsection A-A

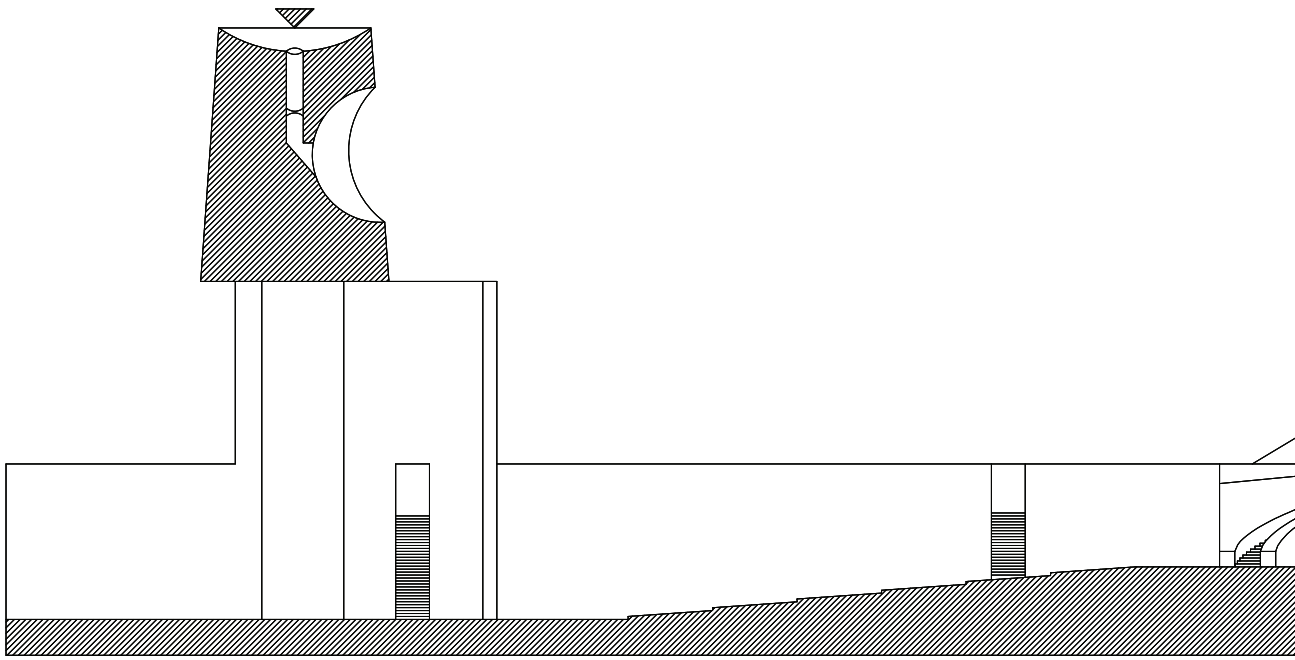

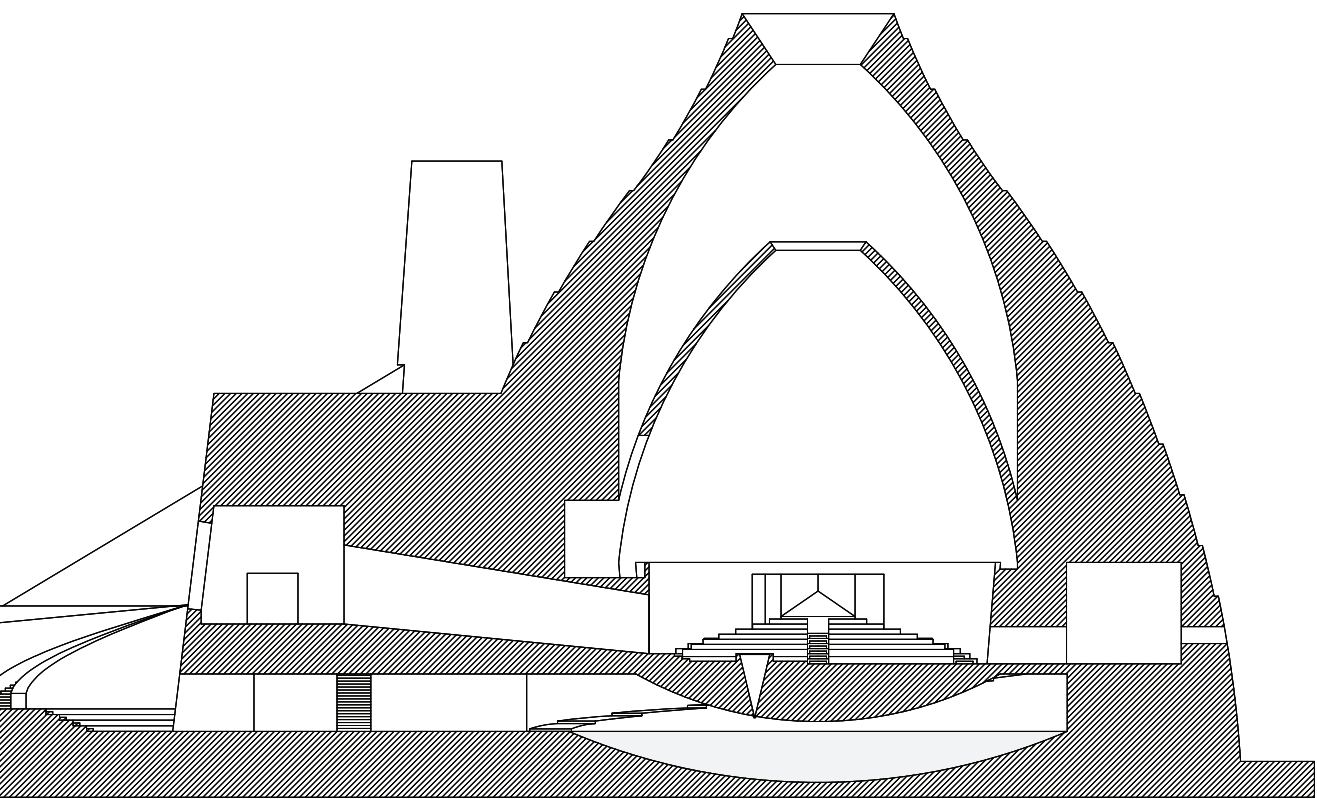

Ceremonial building, plan 1

- 1, ceremonial small court
- 2, entrance passage
- 3, basin
- 4, antechamber

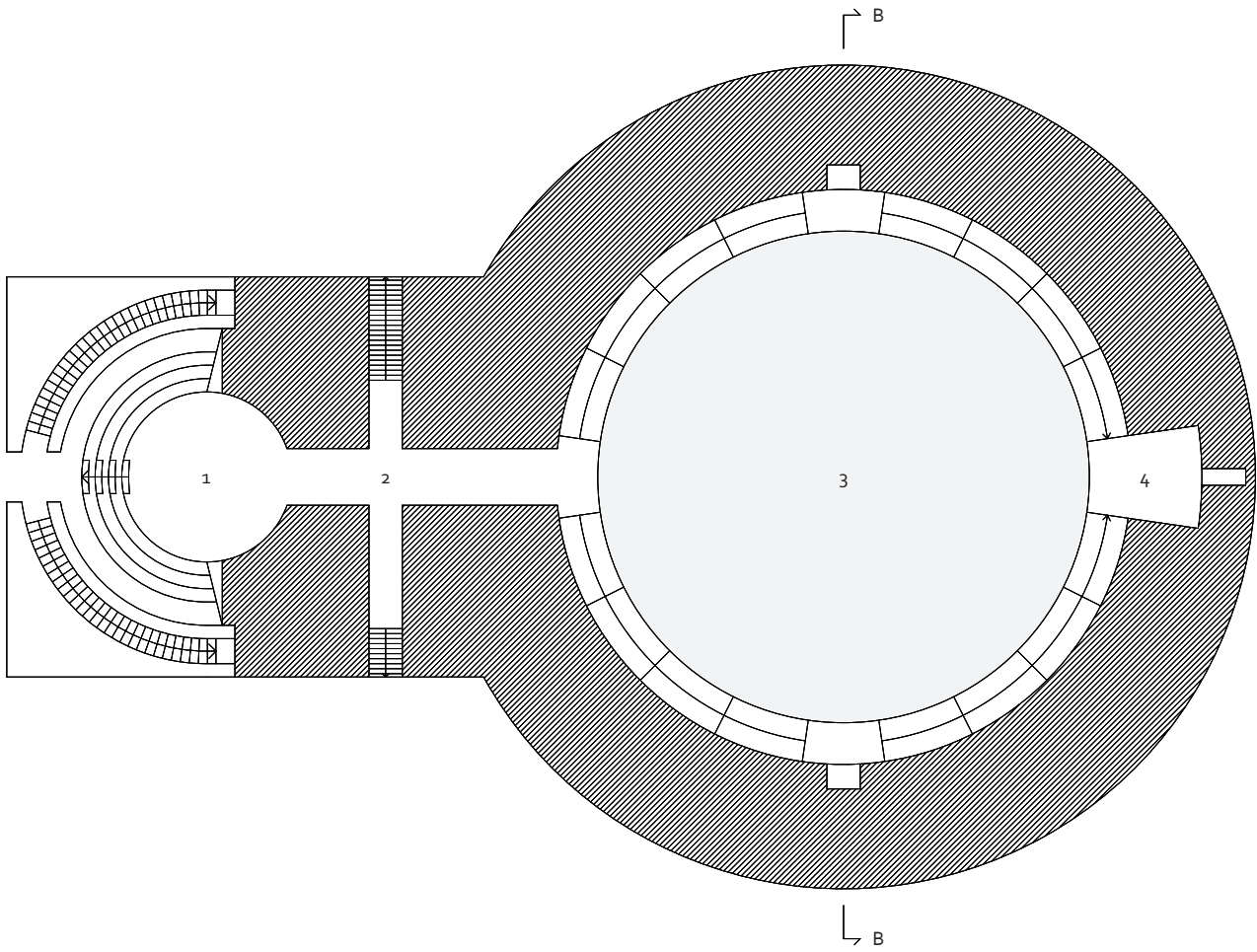

Ceremonial building, plan 2

- 1 antechamber
- 2 ceremonial chamber
- 3 stage
- 4 light barrel
- 5 bifurcation space
- 6 egression hall

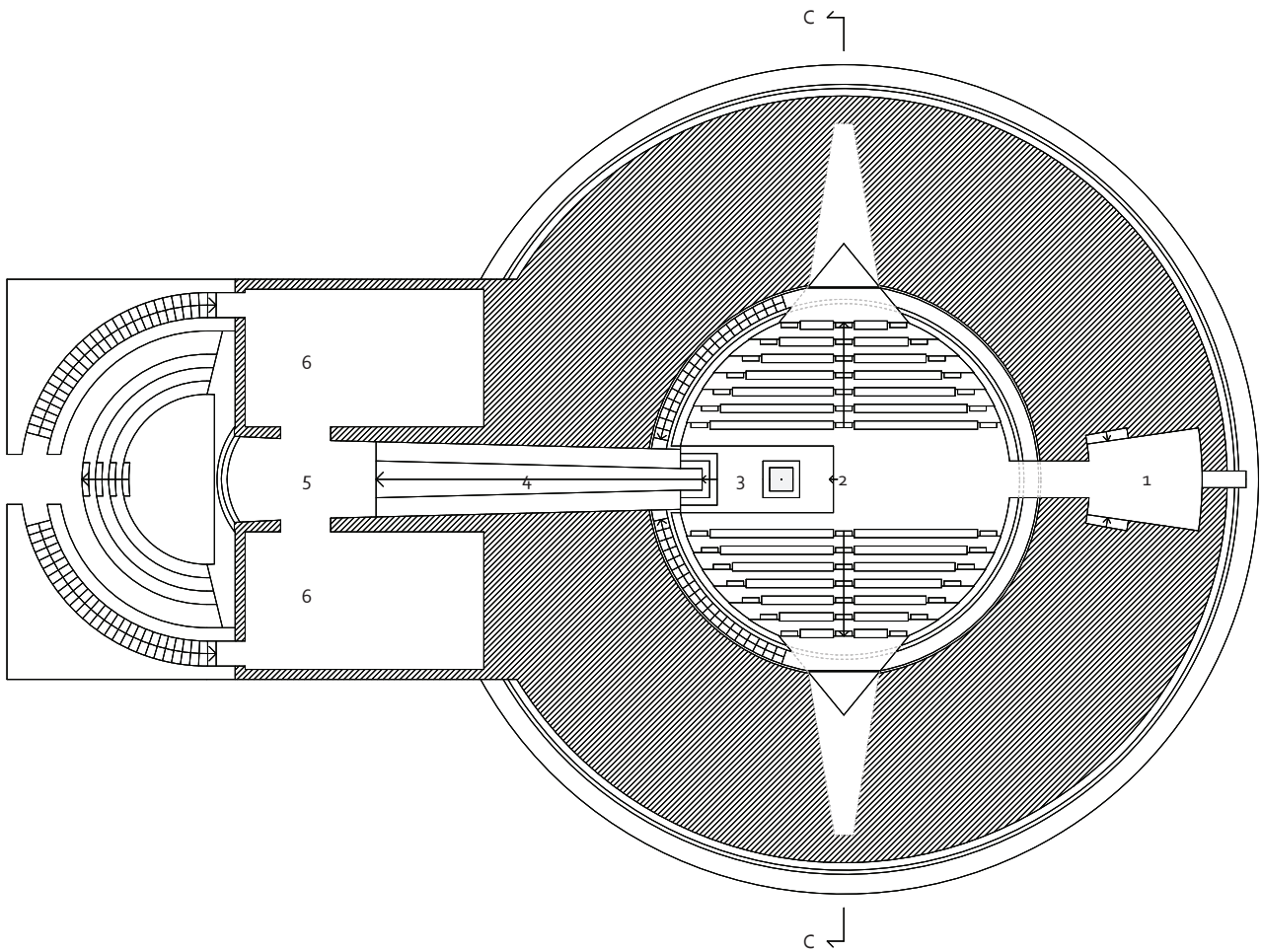

Section B-B

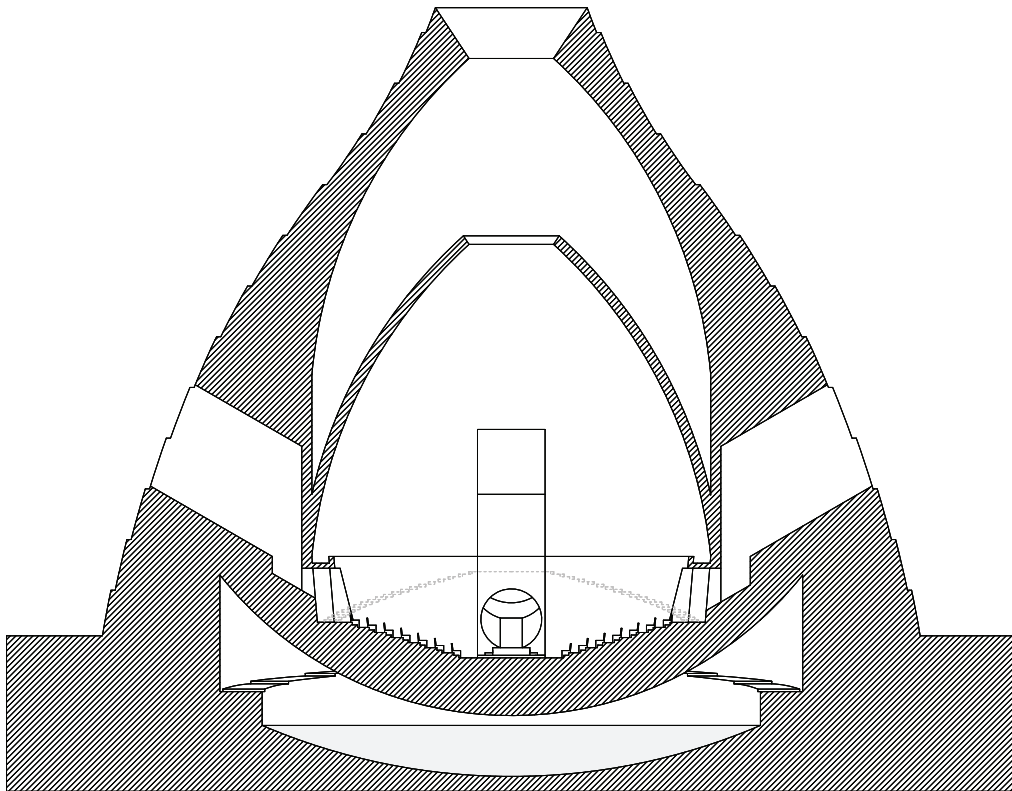

Section C-C

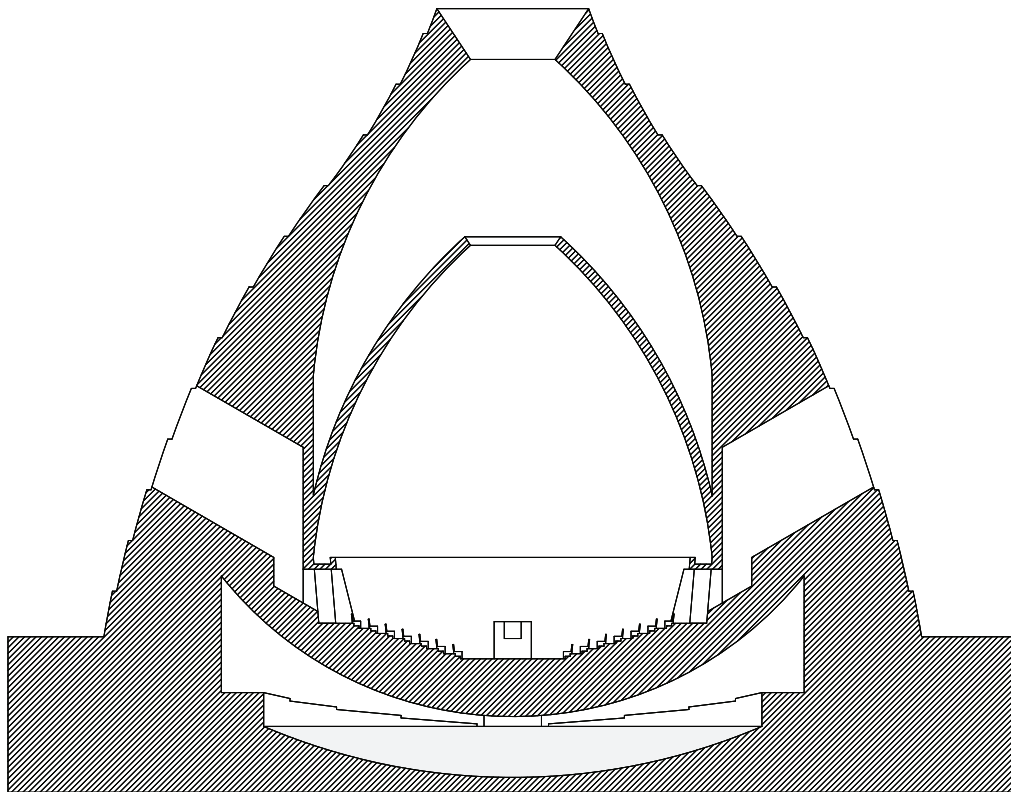

Contemplation chimney

1, 82 step climbe

2, contemplation space

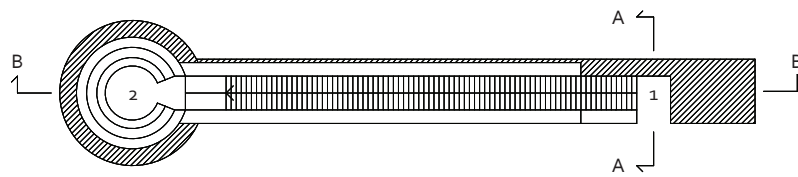
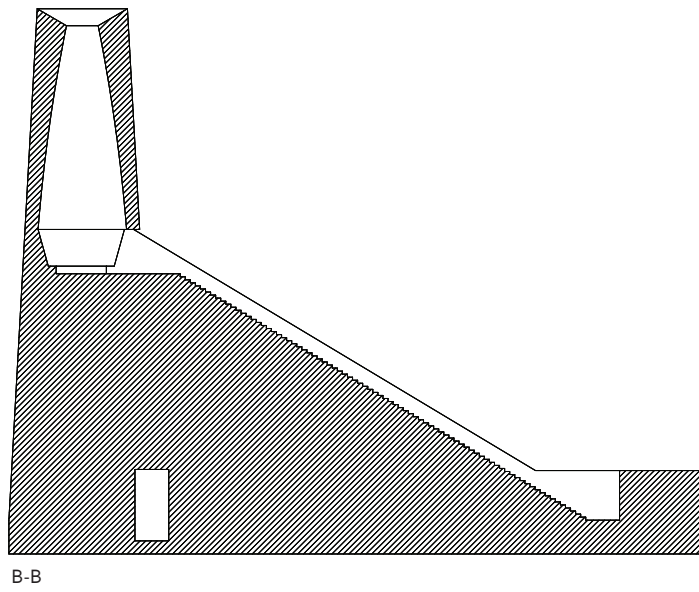
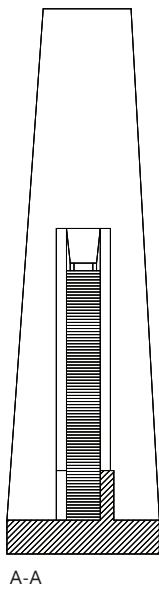

Sun tower

1, entrance court

2, trifurcation space

3, ceremonial great court

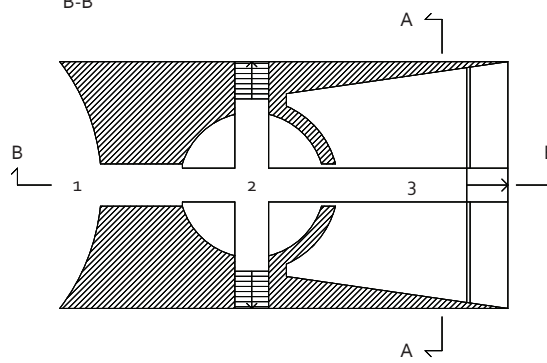
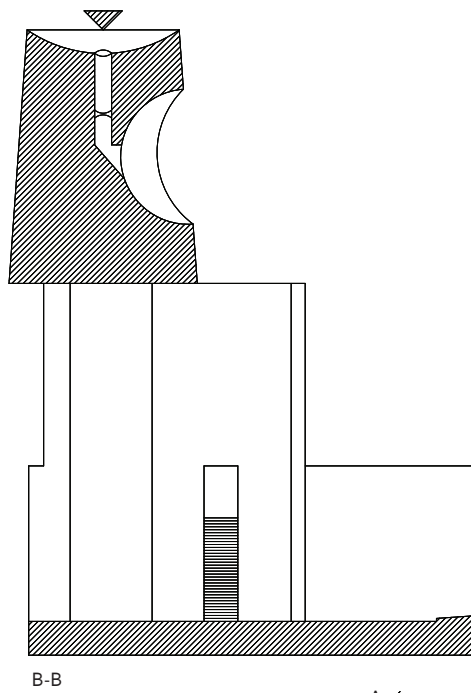
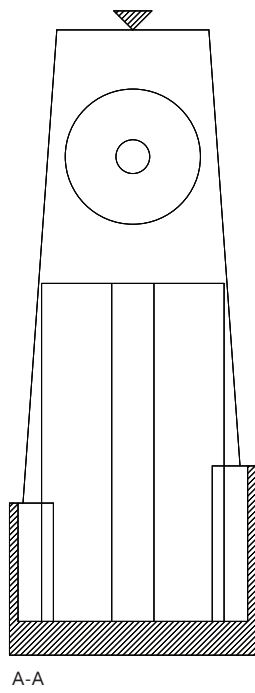

The south contemplation gardens

- 1, frame path
- 2, observation pavilion
- 3, sculpture pond
- 4, pause gallery
- 5, reflection pond
- 6, sculpture back frame
- 7, gravel garden

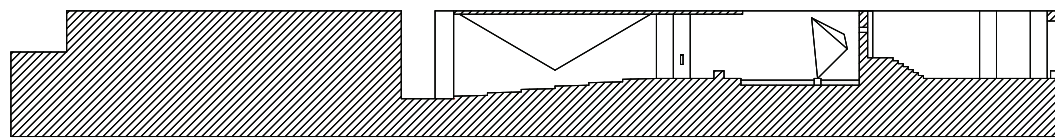
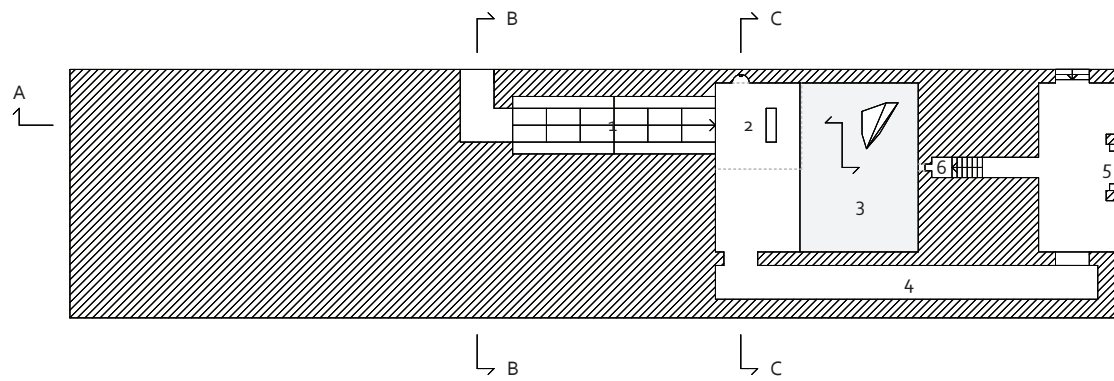

A-A

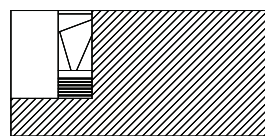

B-B

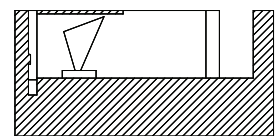

C-C

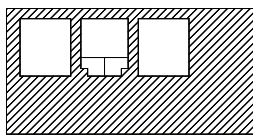
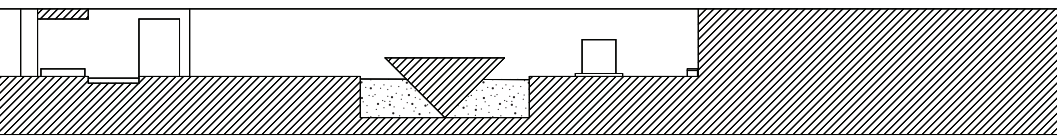
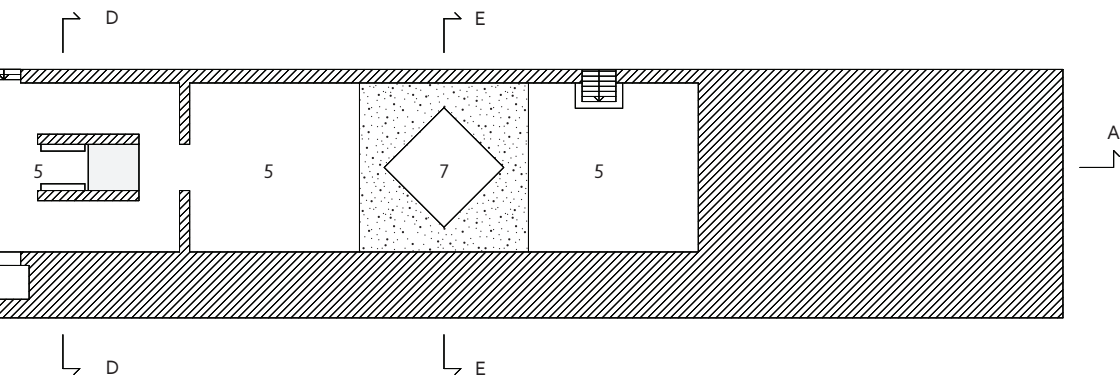

D-D

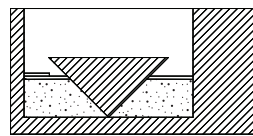

E-E

The south contemplation gardens

- 1, gravel garden
- 2, 82 step climber
- 3, form table

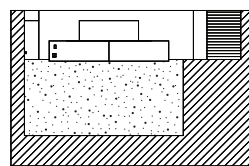
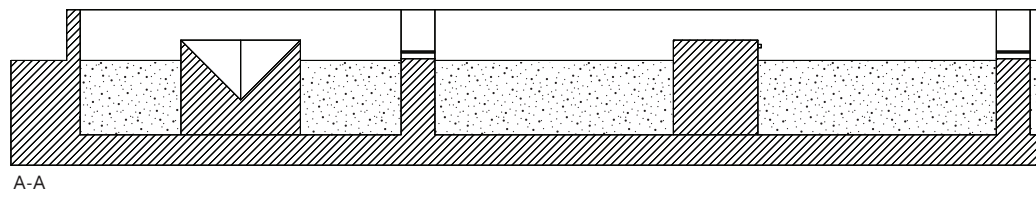
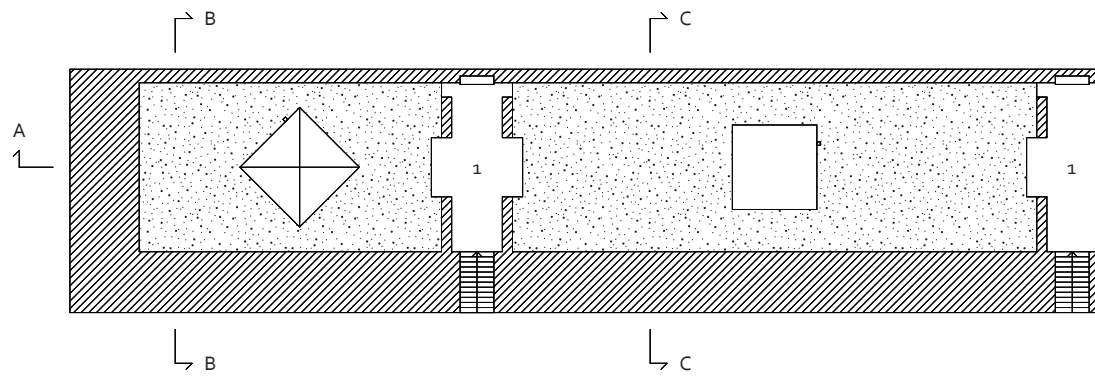

B-B

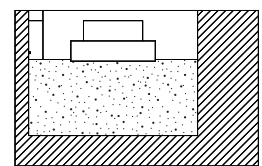

C-C

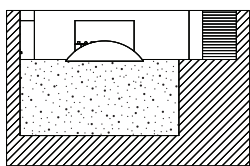
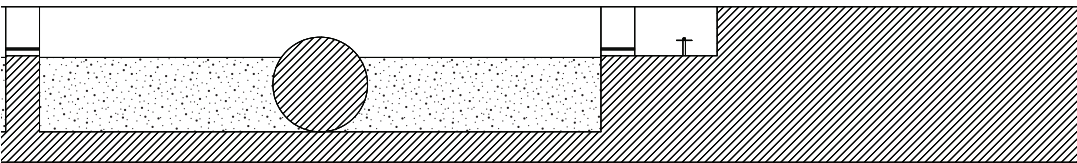
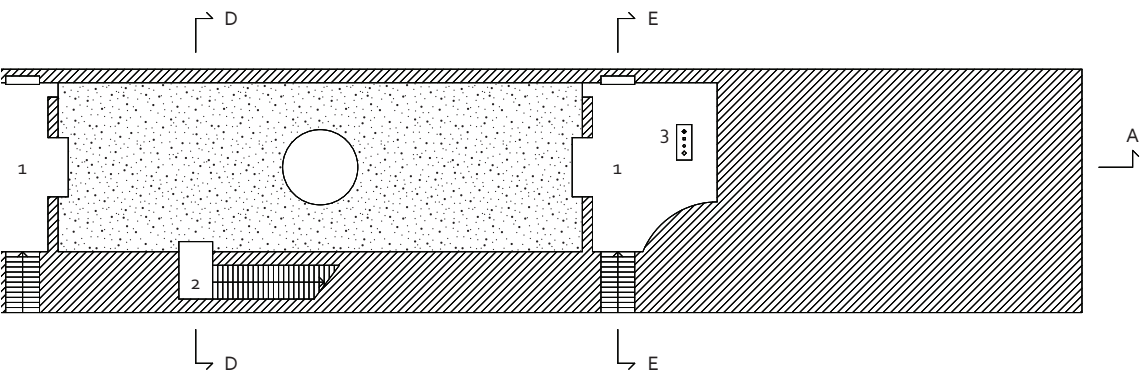

D-D

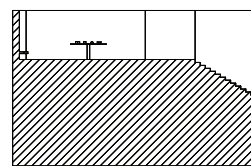

E-E

Discussion

Working in sequences or walks, forces you to be in your work. It is a slow, sometimes tedious process, walking your design over and over again, understanding it a little bit better each time. It is however not only a process that requires a lot of work and time, it can also produce a lot of material. The time one has to put in, or material that should be produced is not fixed. It is naturally scalable. It should however be said that, as with most things, with more time comes greater skill and understanding. Initially the focus is very narrow, restricted to one or a few frames, but with time the material expands and gives greater and greater holistic understanding, filling in the blank spots on the map.

Conclusions

From producing this material, conclusions could be drawn about the benefits, limitations and potential applications of the proposed method. The method inherently holds a certain resistance that makes it time-intensive, which imposes limitations in regards to its applicability. However, this inherent resistance, when conquered, brings with it a deep understanding of one's own imagined spaces. This way of working can therefore hold high didactic value in relation to imagination and spatial understanding.

Recommendation

The natural suggestion or inclination of continuation might be to develop a strict, homogeneous and clearly outlined method; a rulebook that holds ones hand, pointing the finger at each step, ascribing expectations and way of implementation. The recommendation however, based on the considerable number of hours spent working in this way, would be to step away from the rigid, strict and all too clearly defined, and instead strive for fluidity, adaptability and individuality, allowing the personal process to play a formative role from one step to the next.

The suggestion is that the method, or its user, should not principally be striving for something reproducibly tangible. The end product is not primarily the material that is produced, but rather the knowledge and understanding gathered by the time spent working in the material.

It is working in the material to gather knowledge, or in this case of future research, working in the method to deeper understand its limits and potential contributions that, arguably, presents the most challenging and productive continuation. Time is perhaps the most important aspect of the method, and allowing time and greater number of drawings, layers of complexity and complexity of design to be the guide and challenge force of any potential future research project would, based on the work so far, most assuredly be the recommended way forward.

Bibliography

Literature

Cullen, G. (1961). *The Concise Townscape*. United States of America, New York.
Van Nostrand Reinhold.

Eisenstein, S. (1989). Montage and Architecture. *Assemblage*, 10, 111 - 131.
doi: 10.2307/3171145

Kierkegaard, S. (2009). *Concluding Unscientific Postscript*. United Kingdom, University
Press, Cambridge

Imagery

All images. © 2018 Björn Lindell. All rights reserved.

