

Effects of a fishbone strategy on line balance efficiency

A simulation study at Volvo Trucks Tuve

Master of Science Thesis

HENRIK RANSTRAND

MOHSEN ZIAEENIA

Department of Product and Production Development

Division of production systems

CHALMERS UNIVERSITY OF TECHNOLOGY

Göteborg, Sweden, November 2013

Effects of a fishbone strategy on line balance efficiency

- A simulation study at Volvo Trucks Tuve

Master of Science Thesis in the Master Degree Programme Production Engineering

HENRIK RANSTRAND

MOHSEN ZIAEENIA

Department of Product and Production Development

Division of Production Systems

CHALMERS UNIVERSITY OF TECHNOLOGY

Göteborg, Sweden 2013

Effects of a fishbone strategy on line balance efficiency

- A simulation study at Volvo Trucks Tuve

HENRIK RANSTRAND

MOHSEN ZIAEENIA

© November 2013 Henrik Ranstrand & Mohsen Ziaeenia

Examiner:

Bertil Gustafsson

Department of Product and Production Development

Division of Production Systems

Chalmers University of Technology

SE-412 96 Göteborg

Sweden

Telephone + 46 (0)31-772 1000

Cover:

A picture illustrating production modularization thinking.

Printed by

Reproservice, Chalmers

Göteborg 2013

Abstract

This master thesis has been carried out at Volvo Trucks in order to answer the question “how will line balance efficiency change when following a modularization concept with fishbone layout instead of doing lots of different tasks in the main assembly line?” Currently a lot of different tasks are made in the main assembly line which due to the high product variety causes line balance efficiency losses. In order to do this study, a concept of modularization in production with a fishbone layout has been studied. This concept has been modeled with discrete event simulation in order to find the balance efficiency in the final assembly. The current final assembly has also been modeled in order to find out the line balance efficiency in production today.

The result of the DES-models of modularization concept shows high task variation in each fishbone. This model considers different scenarios and layouts for managing the fish bones e.g. average balancing, maximum balancing, serial line layout and parallel station layout in each fishbone. Based on the results of this study, following the modularization concept caused no increase on line balance efficiency losses. However, the improvement in line balance efficiency depends on the considered scenario. The result of each scenario differs from each other which led to the conclusion that the line balance efficiency in this modularization concept is highly dependent to the way each fishbone is organized and managed. The given possibility from the modularization concept to manage each fishbone separately and in different ways is concluded as the most important finding from this study.

Acknowledgements

This report is the result of a master thesis carried out at Volvo Trucks by two masters' student in production engineering master's program at the department of Product and Production Development at Chalmers University of Technology.

We would like to thank Fredrik von Corswant at Volvo Trucks for supervising this project and for all the support that we got during this study. We would also like to thank all the people at Volvo Trucks that helped us during this study, especially Michael Voemel and Göran Levin. Finally, we would like to thank our supervisor at Chalmers, Jonatan Berglund, as well as our examiner, Bertil Gustafsson, for guiding us through this master thesis.

Table of contents

1. Introduction.....	7
1.1 Background.....	7
1.2 Problem definition	7
1.3 Purpose	8
1.4 Goals and deliverables.....	9
1.5 Delimitations	9
1.6 Thesis outline.....	9
1.7 Glossary	10
2. Theoretical framework.....	11
2.1 Introduction to production systems	11
2.2 Assembly system	11
2.2.1 Station	12
2.2.2 Work task	12
2.3 Assembly Layout.....	12
2.3.1 Line layout	12
2.3.2 Parallel line layout	13
2.3.3 Fishbone layout.....	13
2.4 Line design	14
2.4.1 Balance losses	14
2.4.2 Task allocation	15
2.5 Product variety.....	16
2.5.1 Customization	16
2.5.2 Modularization.....	16
2.6 Simulation.....	18
2.6.1 Why simulation.....	19
2.6.2 Methodology for simulation	19
3. Method	21
3.1 Research Strategy and Design	21
3.2 Pre-study.....	22
3.2.1 Literature study	22

3.2.2	Background study	22
3.2.3	Interviews.....	22
3.2.4	Observations	23
3.3	Simulation study	23
3.3.1	Data gathering	23
3.3.2	Coding of model	23
3.3.3	Verification and validation	24
3.3.4	Experimental design.....	24
3.4	Analysis of results	24
3.5	Reliability and validity of the master thesis	24
4.	Case description	27
4.1	Volvo Production System.....	27
4.2	Assembly processes	27
4.2.1	Factory Layout	28
4.2.2	Main Assembly Line.....	28
4.2.3	Sub assembly lines	28
4.2.4	After the main assembly	28
4.3	Product variety at Tuve.....	28
4.4	Databases	29
5.	Implementation	31
5.1	Pre-study	31
5.1.1	Literature study	31
5.1.2	Interviews.....	32
5.2	Simulation study	33
5.2.1	Data gathering and management.....	33
5.2.2	Model building	34
5.2.3	Verification and validation	39
6.	Result and analysis.....	41
6.1	Current Situation.....	41
6.2	FFC	41
6.2.1	FFC with average balancing	41
6.2.2	FFC with maximum balancing.....	42
6.2.3	Differences in FFC run with maximum and average balancing	42

6.3 Comparison between FFC and Current situation	43
6.3.1 Average balancing for sub-flows in FFC.....	43
6.3.2 Maximum balancing for sub-flows in FFC.....	44
6.4 Rear Axle Sub flow	45
6.5 Current level of modularization.....	46
7. Discussion	47
7.1 Findings	47
7.1.1 Maximum-balancing	48
7.1.2 Sequencing	48
7.1.3 Different layout.....	48
7.2 Limitation and consideration	49
7.3 Sustainability	50
7.4 Possibilities and recommendations.....	50
8. Conclusions.....	51
9. References.....	53

1. Introduction

In this chapter a short description to the reason for this study is presented. First, a brief background regarding the Volvo and one of its challenges in its production system is presented. Following, the objective and goals of this master thesis are described. At the end, the delimitations, thesis outline and the list of abbreviations are presented.

1.1 Background

Volvo Group Trucks is one of the major manufacturers of trucks in the world and includes the brands Volvo Trucks, Mack, Renault Trucks and UD Trucks. Volvo Trucks is specialized in heavy trucks where more than 95% of the trucks produced are over 16 ton. Totally there are around fifty plants spread across the world divided between the four brands. One of these plants is located in Tuve, Gothenburg. The Tuve Plant was established in 1982 and in 2011 close to 20000 trucks was produced. All trucks produced at Volvo Tuve have been ordered by customers and are highly customized based on their wishes.

Daaboul et al. (2011) defines mass customization as producing customized products with a cost close to that of mass production and consider it as a requirement to stay competitive in the market. As a result of mass customization the manufacturing processes might become more complex and costly. Following the mass customization strategy leads to the use of mixed model assembly systems that are able to handle the product variety and assemble different variants in the same assembly system. However, by increasing the product variety, the assembly process might encounter higher complexity and lower productivity and quality (Wang et al. 2011).

Volvo Trucks has continuously worked in order to eliminate negative effects of mass customization and reach high economies of scale while keeping high level of customization.

1.2 Problem definition

As been described earlier Volvo has a strategy of providing their customer with a highly customized truck. This has introduced a high level of complexity in the entire manufacturing organization. Focusing on the assembly process, it has led to producing a large number of unique trucks (variants) in the same assembly line. As these truck variants differ a lot, as an example the length of chassis vary between 7 to 12 meters, the amount and type of tasks related to each truck varies which leads to assembly time variations. Since a large amount of the customization is carried out in the main assembly line (MAL), balancing of the line is hard and eventually losses will occur. By increasing the amount of tasks in the MAL and simultaneously decreasing the flexibility in the assembly line, inefficiency and losses have been increased. As newer variants require more tasks, the MAL is running out of space. Several types of losses occur in the system because of the large number of variants and tasks related to each variant. It's hard to identify the best way and place to deal with these losses.

Volvo Group Trucks has an approach to improve their assembly process. This approach is defined as Future Factory Concept (FFC) or Volvo Assembly Concept. Focusing on assembly

processes, FFC suggests a fishbone strategy. This generally means to make sub systems (modules) from different components in the sub-assembly lines (bones) and merging them in the MAL. The modules can be for example the power train unit or the complete cab. Currently some of the major parts, such as the cab, engine, and axle are produced and transferred from other production plants. However, these major parts are still not complete modules. The fish bones as described in FFC do not exist to full extent in the current factory. Due to this fact and in order to distinguish them from existing sub-assemblies, they are called conceptual sub-assembly lines (CSAL: s) in this report.

Introducing FFC affects the entire Volvo organization, including organizational structure, product design, material handling, assembly and production processes, supply chain, and factory layout. It's expected that by doing this, losses in the MAL will be reduced but some losses will be transferred to the bones. The hypothesis is that implementing the fishbone strategy will improve the total line balance efficiency in the assembly process compared to the current situation. By focusing on changes in assembly processes, current problems due to the large number of variants in the main assembly line will be transferred to be dealt with in the CSAL: s. Implementing the Fishbone strategy at Tuve plant will cause enormous changes in production plant and even the factory layout, so it is vital to study the outcomes from this strategy in advance. In this study the focus will be on both the MAL and the CSAL: s. In order to reach more reliable results from this study it is necessary to consider all type of possible variants which is very complex due to the high number of truck variants.

1.3 Purpose

The purpose of this master thesis is to explore the effects on line balance efficiency by implementing the fishbone strategy. This study will be based on the production system at the Volvo Tuve plant.

This master thesis tries to study positive and negative effects related to line balance efficiency when implementing the fishbone strategy. This will give the opportunity to examine the validity of the hypothesis described in the problem definition.

Considering the above description the following research question is formulated;

- How will line balance efficiency change when following a modularization concept with a fishbone layout instead of doing lots of different tasks in the main assembly line?

This research question will be answered by creating simulation models of both current situation and the fishbone concept. These models will help to calculate and analyze the line balance efficiency in both scenarios. The model will be created using data from the production system at the Tuve Plant.

1.4 Goals and deliverables

The goals of this master thesis are to:

- Divide tasks between defined fish bones according to FFC and find the target manpower for each fishbone

All the tasks currently carried out in the MAL will be studied and divided between pre-defined fish bones. Based on the given task to each fishbone the required number of operators (target manpower) will be calculated.

- Create a simulation model covering the current MAL

The data for two driven assembly lines will be gathered and a simulation model will be built.

- Create a simulation model covering CSAL: s and future MAL.

The model should be in an operator level, meaning that it considers the theoretical number of operators and calculate line balance efficiency. The simulation model should be able to manage all types of truck variants.

- To present a quantitative assessment of the effects of implementing the fishbone strategy.

The quantitative assessment should include balance losses and the required number of operators for each CSAL.

1.5 Delimitations

- The simulation model will not include material handling.
- In order to design the CSALs no new time study will be carried out. Existing times for tasks and operations will be used. Regarding the CSALs, study of the required area for each CSAL is not included in this project.
- To avoid unnecessary complexity of the simulation model, the focus should be on assembly procedures and therefore some aspects of the assembly process like quality and ergonomics will be excluded.
- Implementation of fishbone strategy may require a redesign for certain parts and a reconstruction of the factory but this will be excluded from the study.

1.6 Thesis outline

The outline of this thesis is based on published guidelines provided by Chalmers University. The thesis is divided into eight chapters described below:

Introduction

This chapter includes the background and problem definition of this study among with purpose, goals, delimitations and a list of abbreviations.

Theoretical framework

The theoretical framework gives insight in the areas that are relevant to the objectives of this thesis. Fields included are assembly systems, customization, modularization and simulation.

Method

The method chapter aims to describe the methodology that this study follows and also how and in which steps this study has been done.

Case description

This chapter gives more detailed information about the actual production at Tuve. Also included is description of data bases used in this study.

Implementation

The implementation chapter describes in detail the steps that have been taken during this study.

Results

The results and findings of this study have been presented in this chapter.

Discussion

In this chapter findings of this study are discussed. Furthermore, limitations and issues to be considered regarding the result has been pointed out.

Conclusion

In the conclusion chapter conclusions regarding the results are presented. A short summary of the set goals and research question to this study is described as well as how this study can be improved in the future.

1.7 Glossary

CI – **C**ore **I**nstruction - the lowest level of operator work task descriptions.

CSAL – **C**onceptual **S**ub - **A**ssembly **L**ine

CSO – **C**hassis **S**equences **O**ptimiser - application used by Volvo to form a production sequence that stores production data like truck variants, their production time, cycle-time

FFC – **F**uture **F**actory **C**oncept - a concept developed by Volvo regarding the future product and production

FG – **F**unction **G**roup - categorization of parts and components based on functionality of the component or part, defined and uses by Volvo

LBE – **L**ine **B**alance **E**fficiency

MAL – **M**ain **A**ssembly **L**ine - the final assembly line which complete truck assemble

SPRINT – **I**ntegrated **P**roduction **S**ystem - global manufacturing system developed in-house by Volvo which uses to create assembly instructions and material handling instructions

2. Theoretical framework

The theoretical framework aims to give readers a better understanding about the different topics related to this thesis work. The theoretical framework also acts as the basis for doing the study as well as a toolbox for the analysis of the results. The chapter will contain the relevant topics regarding this project and provide a general overview about assembly systems and its common problems and issues and describe modularization as a way to overcome some of those problems. At the end of the chapter, theory regarding production flow simulation is presented; why it is beneficial to use and what outcomes that can be expected.

2.1 Introduction to production systems

A production system can be managed in different types such as job shops, functional layouts, assembly lines or continuous flows. The type of production system is dependent on the product's type and volume. The assembly line is presented as a suitable and common production layout for final assembly in automobile industry (Purnomo, 2013, Hayes and Wheelwright, 1979). As it's also the case at Volvo Trucks, the assembly line has been investigated in more detail. Figure 1 made by Hayes and Wheelwright (1979) describes what types of processes are suitable in what type of layout.

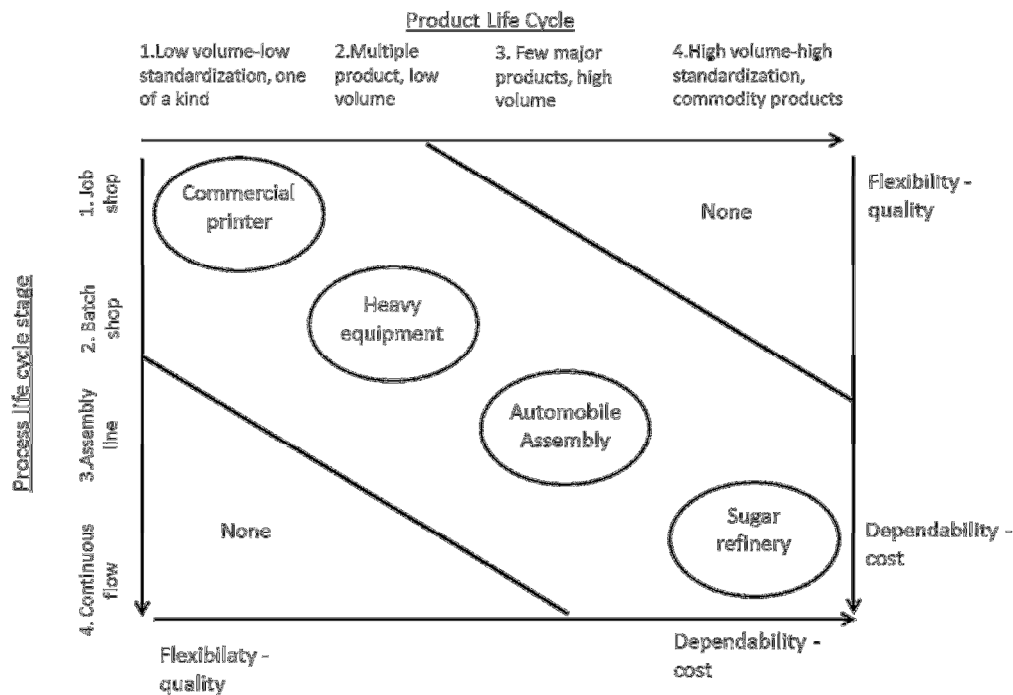

Figure 1: Product – process matrix (Hayes and Wheelwright, 1979)

2.2 Assembly system

An assembly system is a system that performs the act of collecting and mounting different parts together in order to create a product as its output. An assembly system can appear in different layouts as described in previous sub-chapter. Without considering the assembly

systems layout, some elements are common in each assembly system. These elements are stations, work tasks and operators. A basic assembly can be seen in figure 2 which contains stations and operators that perform the work tasks. The material handling between stations can be done in different ways e.g. conveyor belts or automated guided vehicles (AGV).

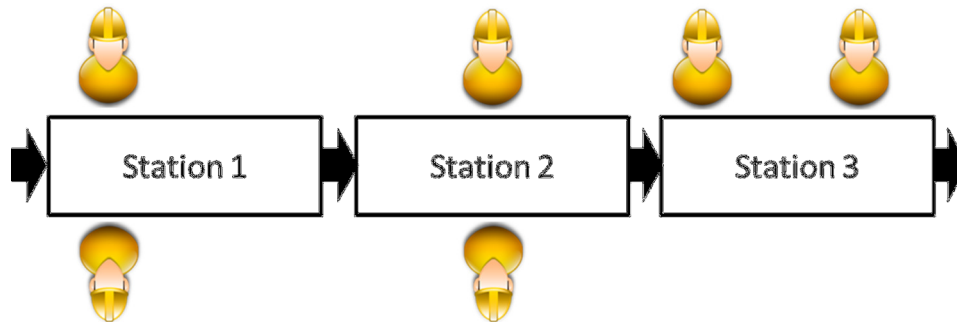

Figure 2: Basic elements of an assembly system

2.2.1 Station

A station is where a number of work tasks are carried out by a number of operator(s). Scholl (1999) divides stations into manual and automated. In a manual station the operators perform tasks by using tools and techniques where in an automated station machines, controlled by operators, perform the work tasks. The flexibility in a manual station depends on the skills and tools of the operators (Scholl 1999). An assembly system may consist of one or several stations.

2.2.2 Work task

A work task, or operation, is a specific task carried out by either an operator or a machine. A work task is not shareable since it can't be split into smaller elements without creating extra work (Scholl 1999). The time it takes to perform a work task is called task time (operation time). From now on, the terms "task" and "task time" will be used in this report. One operator may perform several tasks with different task times so the term cycle-time can be used to address the total time that one operator works. It can also be used as a station cycle-time.

2.3 Assembly Layout

In automotive manufacturing, assembly line layouts are most common. They have been used from 1913 when Ford mass-produced the model T-Ford until now. Even though assembly lines have been most frequently used, other layouts have also been experimented with. At Volvo plant in Uddevalla they used a parallel flow layout to build cars and gained international fame for that in the 90's. An assembly line might be paced or un-paced. All tasks can be carried out in a single line or the assembly line can be feed with different sub-assemblies (e.g. fishbone layout).

2.3.1 Line layout

A line consists of an amount of stations and operators that perform work tasks along a line. Automated guided vehicles (AGV), conveyor belts or similar mechanical solutions connect the stations to each other. The assembly line may be in a straight line or in e.g. a u-shape. The assembly lines are either moving continuously (driven line) or stops at each station (Scholl,

1999). In a driven line the worker are moving along the work piece and when entering the next station the worker returns to the beginning of the station and repeat the work. Scholl (1999) states that characteristics of a line layout are among other: high capacity utilization, low cycle times, low manual material handling and relatively monotonous work.

2.3.2 Parallel line layout

In an assembly plant it is also common to use parallel lines to produce one or several products. It can help to increase the flexibility but it also requires more capital investments (Scholl, 1999). The line can consist of one or several stations. The parallel flow layout at Uddevalla (in production 1988-1993) can also be placed under this category when the parallel lines just include one station. In a parallel flow, the operators' works in teams and have high cycle times, high amount of work tasks and high responsibility (Lootridge, 2004). In Uddevalla one car was built in one station (Ellegård, 1996). In this report, the term parallel station layout will be used to describe a parallel line flow when the line consists of only one station.

In figure 3 a schematic view of a basic parallel station layout is presented where station 1 and station 2 are able to do the same tasks and the output of these stations will be send to the customer, inventory or next process in the production.

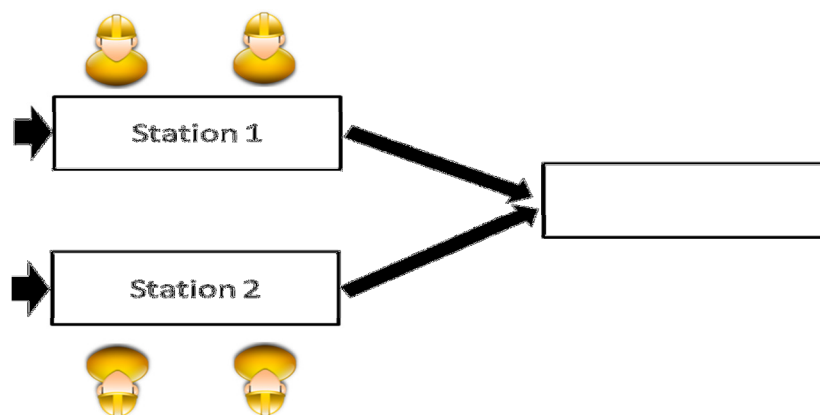

Figure 3: Parallel station layout

2.3.3 Fishbone layout

The idea with a fishbone strategy is an amount of sub-assemblies connected to a main line. The sub-assemblies are producing different modules (sub-systems) that are merged on the main line. Figure 4 shows an example of a fishbone layout. The round circles and the line between them symbolize the assembly line where the modules are mounted in the marriage points. Connected to the marriage points are sub-flows with different amount of stations. In these sub-flows the modules are built.

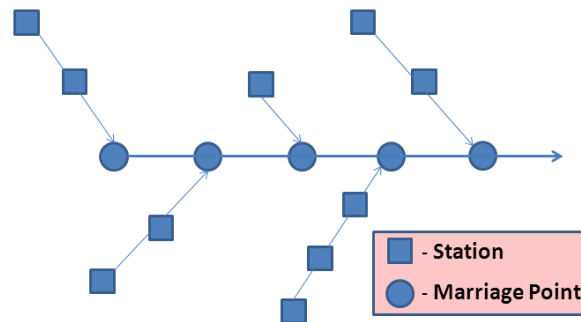

Figure 4: Fishbone layout

2.4 Line design

There are some common and general factors for designing any production system. These factors focus on required tools and machines, needed space, production logistic (material handling) and necessary manpower. Beside these factors some other factors consider when the production system has a line layout. Number of stations, takt-time, balancing the line and minimizing any kind of stoppages in the line are some of these factors. This study will focus more on line balancing. A line will be fully balanced if all the operator and stations through the entire line have the same amount of workload. Any failure to have exact same amount of work load for all operator leads to balance losses. When the line is a mixed-model assembly line the variation between different variants might also lead to balance losses which can also be called variant losses.

It's essential that losses are kept as low as possible in order to maximize profits. Balance losses occur when there are deviations in work load at different stations or between operators. To minimize balance losses it's important to allocate tasks in a sufficient way.

2.4.1 Balance losses

Failing to assign the equal amount of task to all stations through an assembly line cause balance losses. The different between cycle time (used time) and available time (takt time) in a station can determine the amount of losses at station. In an assembly line with several station the losses at all stations determine the line balance losses. Figure 5 illustrates Takt time, cycle time and balance losses related to each other.

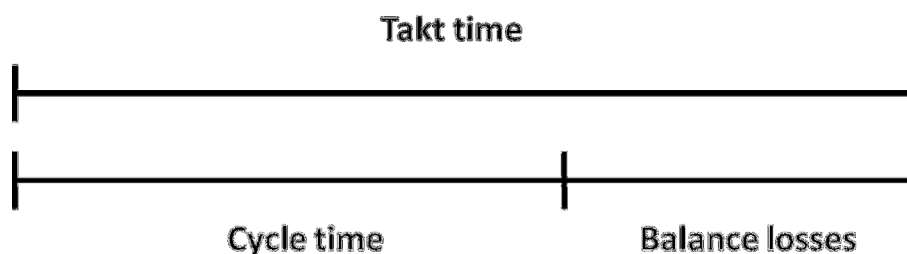

Figure 5: Takt time, Cycle time, and Balance losses in one station

In order to avoid balance losses or minimizing them several methods can be used. One way can be to break the whole operation in to minimum rational work elements which are the smallest tasks that the operation can be divided to. These work elements can then be devoted to different stations and operators considering the precedence limitation. However this method will not guarantee zero balance losses. Having an assembly line, which contains high number of operations and tasks, will lead to complexity. To assign the tasks to the stations considering the predecessor and successor of the tasks is vital. Having a high number of tasks, especially in a mixed-model assembly line, will make it hard to consider all the variants and find the optimal task allocation (Scholl 1999). In the mixed-model assembly line after allocating the tasks finding the right production sequence is of importance in order to minimize the balance losses (Bukchin, 1998). In the mixed-model assembly line, the line can be balanced in different ways. It can either be maximum-balanced or average-balanced. When the line is balanced with respect to the most time consuming model (heaviest model), maximum balanced, the operators have enough time to produce the most time consuming model. Balancing losses will occur when operators are working on the less time consuming models. The line can also be balanced based on the model with average cycle time, called average balanced, or based on the model that has highest rate of production. In this case the production sequencing plays an important role to minimize the balance losses.

Another way to avoid balance losses to some extent is to pre-assemble the components before the assembly line. Using buffers, changing the workload speed and using parallel stations are also possible ways to reduce balance losses.

The line balance efficiency (LBE) is an indicator to measure how efficient the line is balanced. Other measurements, like balance delay and balance losses, are closely related to LBE. The LBE formula is presented in equation 1 and is the same formula used today by Volvo (Hellman, 2013) and also has been stated by Vaccaro (2013) and Andersson (2011). The sum of the task times is the time it actual takes to build the product in all the stations on the line. The available time is the number of operators on the line multiplied by the takt time.

$$LBE = \frac{\sum \text{task times}}{\sum \text{available time}}$$

Equation 1: Line balance efficiency formula

2.4.2 Task allocation

In any assembly line which consists of a series of stations, allocating tasks to the stations is one of the biggest concerns for any line designer. There are three major issues that task allocation in an assembly line aims to address. The line designer may focus on one or several of the following issues;

1. The first issue is to keep the number of stations that are necessary in order to produce the product and meet the demand as low as possible. This issue has been called ***problem type I*** in different articles (Uğurdağ et al. 1997).
2. The next one is to decrease the cycle time for fixed number of stations. This issue has been mentioned as ***problem type II*** in line designing (Rachamadugu and Talbot 1991).

3. The last issue is to divide and assign tasks as equally as possible to all stations. This issue addressed as *problem type III* (Uğurdağ et al. 1997).

The focus for the line designer might be any of above issues and different mathematical approach might be used to address these three types of problem.

2.5 Product variety

One of the major concerns in the manufacturing industry today is the large product variety. Customers that are demanding customized products are forcing the industries to become more flexible and agile (Hu et.al 2011). As customization becomes more usual, ways to increase the flexibility are being searched by the industry. One possible solution could be modularization.

2.5.1 Customization

From 1960's, when mass production started to deteriorate, other approaches and paradigms such as just in time, flexibility, agility and customization flourished (Duguay 1997). By globalization of the market, the competition became harder for the industries, so customer demand became of more importance than earlier. In the late 1980's, the mass production paradigm was forced to leave its place to the mass customization in order to satisfy the customer (Hu et.al 2011). In this term manufacturers were forced to provide the customers with more varieties and even involved them in the design of customized products with a price close to mass-production cost. This mass customization eclipsed the entire organization and required a new approach to manufacturing. As Hu (2011) indicates, the customization can be achieved in the factory through design phase, fabrication or during assembly phase or even out of the factory at the sale stage or use phase. Moving toward mass customization in order to survive in the market was necessary. However, the fact cannot be neglected that mass customization and product variety introduces more complexity to the manufacturing system and may have negative impact on quality and productivity (Hu et al. 2008).

Mass customization can also be achieved through product or process variety. By mean of product variety terms like modularity, commonality and product platform which are closely related to each other can be considered as helpful tools. Modularity focus on making a product by "*loosely coupled*" components where commonality focus more on using same components or modules in different variants of the product. Product platform can be described as underlying parts or technology which is the basis of the product e.g. chassis in the automotive industry. Having a flexible product platform will allow to create a variety of products based on the same platform. Generalized production line platform, which make the reconfiguration of the production line possible, as well as production line modularization can be of great help to achieve the mass customization through the process variety (Daaboul 2011, Wazed et al. 2012). Hu (2008) claims that mixed model assembly lines provided by assembled modules can play a big role to deal with the increased product variety.

2.5.2 Modularization

In order be able to respond to the customer and market demands for different variety of a product, companies are forced to move toward mass-customization which also some inefficiency and losses of performance will occur. In order to deal with this drawback the

term modularity has been applied widely. The concept modularity has been focused in many areas, especially modularity in design but also modularity in use and modularity in production. Modularity in production has been introduced as an important tool for having a flexible and agile manufacturing which can handle mass-customization with high performance (Pandremenos 2009). Modularity has been defined as a concept which can be used in order to ease the managing of complex systems and decrease the drawback of having mixed product variety in a production system (AlGeddawy and ElMaraghy 2013, Pandremenos 2009).

The modularity in design focuses more on the design of the parts of the product and suggest on modular architecture. As an example this can help to decrease the number of parts when the product variety increases. On the other side modularity in production focuses on assemble number of parts and component to create a module which later on will merge with other modules. One example of modularity in production can be a fish bone assembly where each bone produces a complete module. These modules are then merged together in the main assembly line. In automotive industry, engine and the cab can be considered as typical modules which are manufactured outside of the main line. The modularity in production and design are related to each other. Modular design can and will ease the implementation of modularity in production. In which extent a product should be modularized depends to different factors such as available technology, cost of design, redesign and manufacturing. The modularization needs to add value and be beneficial. Different companies in the same branch have different extent of modularization in their product and it is hard to compare their product's modularity. Although when an existing product or production system is going to be re-designed with higher modularity, the modularity of that system can be compared to the goal which can be considered as the level of modularization.

Different terms and words has been used in articles by different authors where for example Pandremenos (2009) mentions that by pre-assembling many components a module builds, Salvador et al.(2002) describe that by attaching different parts, a component creates. In this report, the term of modules and sub-systems will be used for a number of parts that are assembled together in sub-assembly lines and later merged together in order to produce a product.

2.6 Simulation

A simulation model is an artificial creation of a real system which is created in order to be used instead of the real system for tests, experiments, education, and predictions of performance and behavior. Banks (2010) defines a simulation study as following;

“A simulation study is the imitation of the operation of a real-world process or system over time. Whether done by hand or on a computer, simulation involves the generation of an artificial history of a system and the observation of that artificial history to draw inferences concerning the operating characteristics of the real system.”

In order to perform any simulation study a simulation model is to be created which is a simplification of the real system under investigation. The model needs to cover the criteria of the real system in a sufficient level but in the same time it is nearly impossible that a model is corresponding to all attributes and factors of the real system. It is both due to the complexity of real systems and the fact that it's often unnecessary to cover all the factors. It is enough that the model answers the questions that it supposed to be answered. As a common expression a model should be “as simple as possible but not simpler”.

Simulation as a tool is preferable to use in a large number of areas. It can and has been used in areas such as manufacturing applications, logistics and transportation health care and military applications. In manufacturing systems simulation studies can be used to identify bottlenecks and optimize maintenance design. It can also give the opportunity to study the effects from new layouts, machines and management's approaches in a controlled environment before the actual implementations. In transportation industry it can help to identify possible down pits. In the health care industry simulation can assist in reducing lead times (Banks, 2010).

In general a simulation study can help to save money or improve services. This is made by avoiding disturbances in the real system for any changes before testing and evaluating those changes in a virtual simulation model. It can also be accomplished by trying different “what-if” scenarios for any improvement in order to reach the optimum recommendation. Even though the main area with simulation is to save money other sustainable factors are also involved. Improving systems may very well lead to lowered emissions and environmental sustainability.

Simulation models are divided in to main categories, discrete and continuous. In discrete event simulation (DES) the variables change in discrete times and steps but in continuous simulation the variables change continuously (Özgün and Barlas, 2009). Choosing one of them depends on the nature of the system under investigation. However, systems might have both of them; it's possible to simplify the system and chose one of these categories. E.g. in an assembly line with conveyor belts the position of the products change continuously but it's still suitable to use DES. An example of a case suitable for continuous simulation is when simulating the transformation of energy in an engine. From now on when describing simulation the focus is on DES because it's the chosen category to use in this study.

2.6.1 Why simulation

As mentioned before the main objective of a simulation study is often to save money. Banks (2010) mentions that a validated simulation models advantages are among others:

- A lot of scenarios can be tested. This is particularly useful when dealing with systems that involves a lot of different variants and when evaluating “what if” – situations.
- A simulation study can be helpful in understanding how a system operates. There is often a belief that it’s in a particular way, something that can either be confirmed or disproved with a simulation model.

As there are many advantages there are also some disadvantages where some mentioned by Banks (2010) are:

- A simulation studies output may be hard to interpret.
- A simulation study may be expensive and time consuming. It’s essential to make sure that the possible savings from a simulation study exceed its cost.
- Bad input data equals bad output data and therefore it’s essential to make sure that the input data are correct.

As mentioned in the advantages, a simulation study may be helpful in order to understand how systems operate. Johansson (2011) is mentioning that simulation is a great tool for testing different scenarios in production. When implementing e.g. a new production strategy simulation is helpful in order to make sure that investments are done in the right place. A simulation study can point out benefits and drawbacks of a new strategy; such as possible production improvements as well as possible pit falls. Simulation can also be of great help when visualizing new scenarios. There is a great possibility that different people working within a process have different views. Making a simulation model can then be helpful in order to make sure that everybody is striving against the same goal.

2.6.2 Methodology for simulation

There are several different guidelines for carrying out a simulation study. According to Musselman (1994) there are steps that are essential for all simulation projects. These steps include problem formulation, model conceptualization, data collection, model building, verification, validation, analysis, documentation, and implementation. Banks (2004) describes a detailed methodology as shown in figure 6.

As can be seen in the figure, any simulation project starts with formulation of the problem and finding the objectives, level of detail and goals of the project. Following, a project plan will be established for carrying out the project. Next, knowledge is gathered through studying the system under investigation. The system under investigation should be simplified and represented in a conceptual model. This conceptual model will include the structure and most important components of the system. Required data needs to be collected with respect to the projects objectives. The data needs to be processed and managed to a usable format. This step is one of the most important steps because it directly affects the output of the system. The quality of the output data from the simulation model is related to quality of the input data. The

model should then be built in chosen simulation software. The behavior of the model should be verified and the output of the model needs to be validated.

According to Johansson (2011) verification means to ensure that each element in the model has been coded and behaves in the right way where validation is a way to secure that the model is a representative copy of the real system under investigation. When the model has been verified and validated, it's time for experimental design to find out how each factor affect the result of the model. This step can be done in a structured way or by a trial and error approach. According to the experimental design, the model needs to be run and the results analyzed. If there is no need to repeat the production runs or new experimental design then the findings should be presented and documented. Last, if the results are satisfactory, the changes can be implemented in the real system.

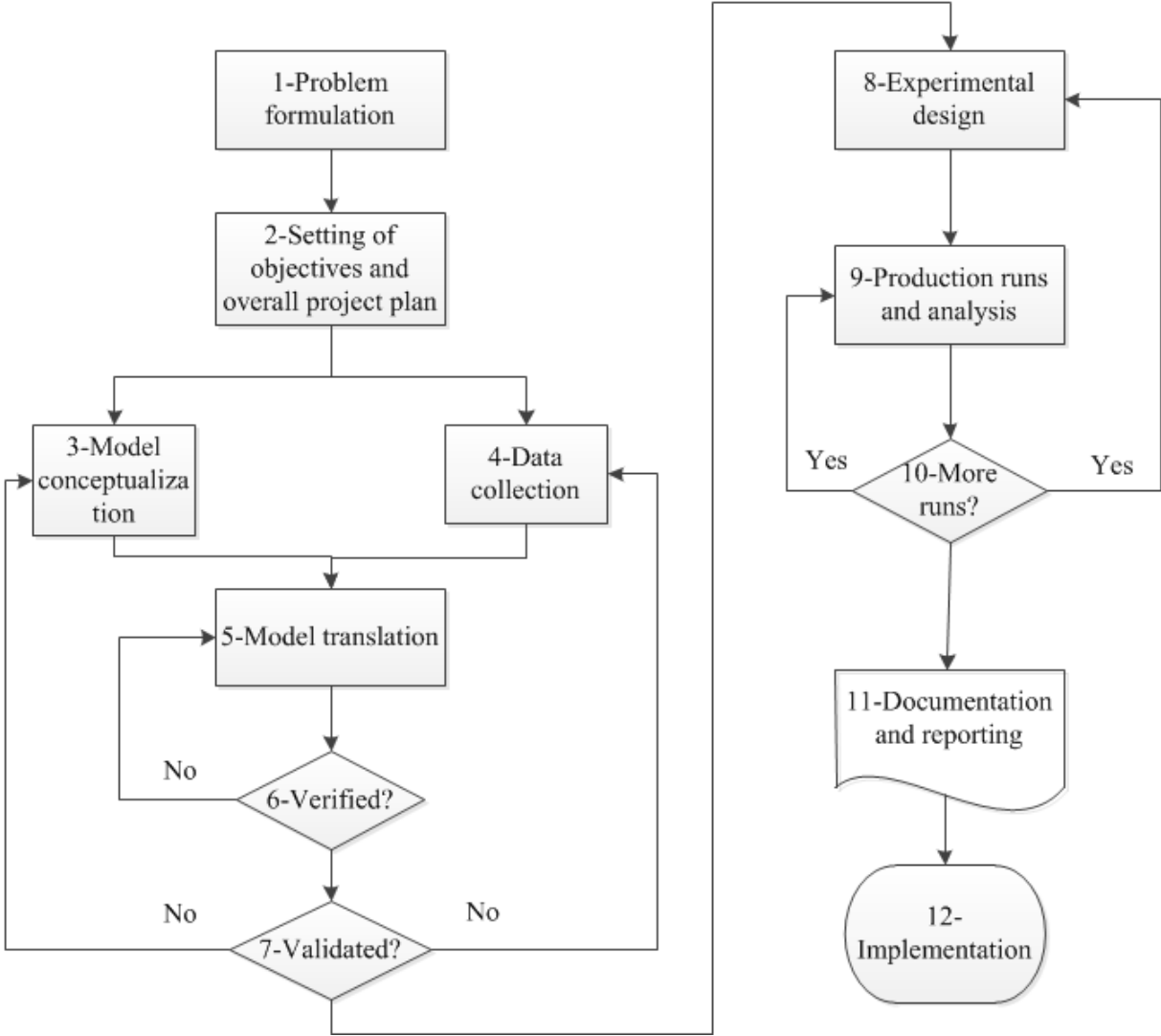

Figure 6: Methodology for discrete event simulation (Banks, 2004)

3. Method

The method chapter aims to give readers an understanding about how the project research is performed. This includes a description of the research study and the data collection as well as how the simulation study was performed.

3.1 Research Strategy and Design

The research strategy aims to be a strategy used to answer the research question;

- How will line balance efficiency change when following a modularization concept with a fishbone layout instead of doing lots of different tasks in the main assembly line?

According to Voss et. al (2002) a case study is beneficial to use when developing new theory, testing existing theory and extending theory. Darke and Shanks (2002) states that a “case study is particularly appropriate for situations in which the examination and understanding of context is important” but not when the theory is well developed and widely accepted. Therefore, it was suitable to choose a case study approach in this thesis in order to find how the modularization concept will affect line balance efficiency. This research follows a single case approach, which allows investigating the area in more detail and achieving a deeper understanding. The approach used to perform this case study is presented in figure 7.

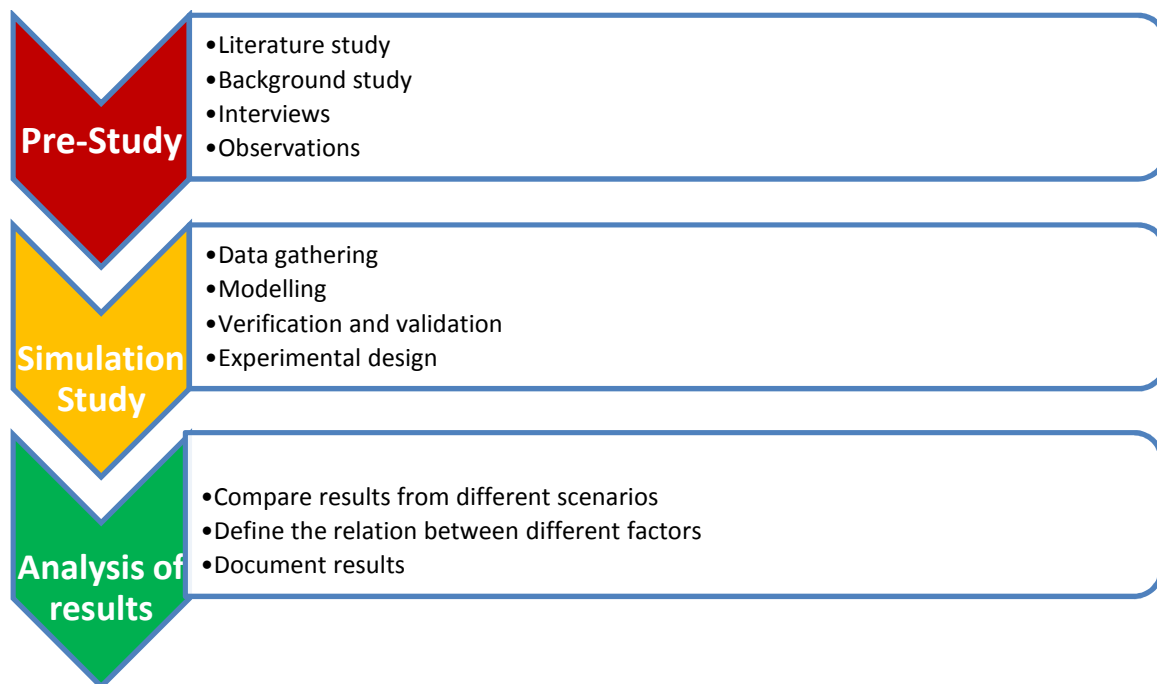

Figure 7: Methodology approach for carrying out the study

The figure above acted as a guideline and checklist to accomplish this master thesis. When doing a study it's easy to lose track, forget points or go into some points in unnecessary detail. It was beneficial to use a well-defined guideline in order to secure that the objectives are fulfilled.

3.2 Pre-study

The pre-study phase designed to gather the required knowledge about the system under investigation and related aspects of the research question. First of all, it was needed to gather general information regarding the company, the processes and problems through background studies, interviews and observations. Secondly, knowledge regarding assembly lines, its problems, customization and modularization was required due to the research question.

3.2.1 Literature study

Literature in the field was collected from articles, documents and books in a systematical way. As there is a lot of documentation in a lot of related subjects the most important keywords were set. These keywords included production processes, flexibility, line balancing and simulation studies. As Volvo's approach is customization and modularization was the core of this study understanding these terms and their challenges and benefits was necessary. Studying the articles related to these keywords formed literature study in order to gather information required for the modeling and analysis. This information was used when later interviewing experts in the respective fields in order to ask relevant questions.

3.2.2 Background study

Internal documents at Volvo used to find previous studies done in the area. The background study also included studying documents regarding the actual production and FFC. As the FFC was a concept created by Volvo, the only ways to find information in that subject was through reviewing the documents and to do interviews. Sources were evaluated critically by help of company co-workers so that no misinformation was given.

3.2.3 Interviews

According to Williamson (2002) interview is a common approach to gather qualitative data during a case study. In this study, the interviews were used to analyze the current situation as well as get directions where to find more data. Interviews were beneficial for the researchers of this study when they had limited knowledge about the actual system under investigation.

Attendees for interviews were chosen with the projects aim in mind. The interviews were supposed to give information about internal databases, production systems at Volvo and Volvo's current status regarding modularization and therefore the interviewees were chosen from different departments and with different skills and experiences.

Interviews of non-structured nature were chosen for the initial interviews when asking general questions regarding FFC and the current status. These interviews led to names of potential interviewees for semi-structured interviews. Semi-structured interviews are interviews where the interviewees are given the same questions but with the possibility to follow up on leads that come up during the interview (Williamson, 2002). As the interviewees for the semi-structured interviews were not set in the beginning of the project but as the study were carried out, new interviewees were chosen along the way in fields where more knowledge was required and where there was a mismatch in information given.

3.2.4 Observations

As information about the current processes as well as the product was needed it was beneficial to visit and do observation in the production plant. The observations were performed by guided and non-guided plant visits.

3.3 Simulation study

Johansson (2003), states that a simulation study may be a part of a case study in order to do experimentations. The simulation study was a feasible tool to deal with the high variety of data related to product variation in this case study. In order to carry out this discrete event simulation study the Banks methodology has been followed to some extent. The banks methodology's steps have been followed until the implementation step which has not been included in this study (figure 5).

Formulating the problem and setting the objectives has been done with support from the supervisors of this study. Different methods have been used when building up knowledge. These methods have been described previously in this chapter. Based on the findings of the previous steps, a conceptual model has been drawn. The conceptual model, which was a simplification of the real system, showed the relations between its elements and has been used when building the simulation model. The data which was necessary to build the model has been gathered with help from experts at Volvo. After verification and validation the model, required test runs have been done based on the experimental design. The outcomes of the model have been analyzed and documented. The major steps; data gathering, coding of model, verification and validation, have been described in more detail below. The experimental design has been described in the implementation chapter in detail.

3.3.1 Data gathering

According to Robinson and Bathia (1995) there are 3 types of data; available, not available but collectable and last not available or collectable. Due to the nature of this project, simulating visionary production processes, the major part of the data was not available or collectable, though data for the current situation model was available in the data bases. The data that wasn't available or collectable has been estimated with the help of experts and available documents. The data available in the databases which were more quantitative data was extracted by IT-experts.

3.3.2 Coding of model

The model was coded with an aim to be flexible and easy to understand. A flexible in this case meant that it should be easy to change input-data without a need of major changes to the code. In the other hand, as the user of the model didn't participate in the initial coding, it was important that the code was easy to understand in order to change later. As the purpose of the model was to test a concept, it was of great importance that the model could visualize the concept in an appropriate level. The appropriate level of the simulation model was chosen based on the project aims. Johansson (2011), states that a simulation model should not be more complicated than necessary. Avoiding unnecessary complexity of the model made it easier to de-bug. The simulation has been done in the software Tecnomatix Plant Simulation 10.1.

3.3.3 Verification and validation

As described in the theory, the verification aimed to ensure that the model is behaving correctly. Some verification was done simultaneously during the coding. The model was verified by using the de-bugging mode after adding any new part to the model. A total verification was also done when the model was considered to be finish. Several de-bugging codes were also added to the model to create self-verification. Following the animation was also used as an approach to verify the correct behavior of the model.

This study covered both an existing system as well as a non-existing system. The first model that covered the existing system was validated by comparing the output of the model with real output from the system. The structure of the model and also the input data has been validated by comparing them with the real system and using the data that existed in the internal databases. As the non-existing model wasn't an imitation of a real-world system the model validation was very hard to do. It wasn't possible to validate the models output with the real systems output, instead the model was validated by ensuring that it would work in extreme circumstances and that the result of the model fulfilled the expectations.

3.3.4 Experimental design

A plan has been created in order to experimental design. The experimental design was necessary in order to find the effects of each factor in the results which, in this case, was line balance efficiency. The experimental design included two different ways of balancing the CSAL: s (average and maximum balancing) and experimenting with a different layout.

3.4 Analysis of results

After making the models and doing several production runs based on the defined experimental design, the results were analyzed. The output from the models was transformed to a common format which made it possible to make a comparison. The line balance efficiency in different experimental scenarios has been compared against each other and also against the result of the current situation model. Then, the factors affecting the result were defined and the relation between these factors and line balance efficiency has been described. At the end the results were visualized by help of different type of tables and graphs and presented in a written report.

3.5 Reliability and validity of the master thesis

The reliability of a study generally aims to control if the output from the study would be the same if someone else was doing the study following the same methodology as Joppe (2000) describes reliability:

"... The extent to which results are consistent over time and an accurate representation of the total population under study is referred to as reliability and if the results of a study can be reproduced under a similar methodology, then the research instrument is considered to be reliable."

The reliability of this master thesis was secured by following the developed methodology and using existing data from internal sources.

Williamson (2002) defines validity as:

“The capacity of a measurement instrument to measure what it purports to measure or to predict what it was designed to predict...”

In general validity answers if a researcher was able to answer the question that was supposed to be answered. To ensure the validity, the goals have been defined clearly and followed through the entire study.

4. Case description

This chapter aims to give readers a better understanding about Volvo Trucks in Tuve. Firstly, information regarding Volvo Production System (VPS) will be presented and later information about the product produced at Tuve factory will be described. Finally, some of the internal databases that have been used during this study will be described.

4.1 Volvo Production System

Volvo production system (VPS) is a long term concept made by Volvo as a guideline for all the activities related to production. The VPS is global and is applied to different extents in all factories across the globe. In figure 8 the VPS triangle are shown. As can be seen in the figure, the customer stays in the top of the triangle since a satisfied customer is one of the core values at Volvo. Providing the customer with high quality products at the right time are two other values in the VPS. These values are secured by continuous improvements, team work and stable processes based on the Volvo Way (Razaznejad, 2011).

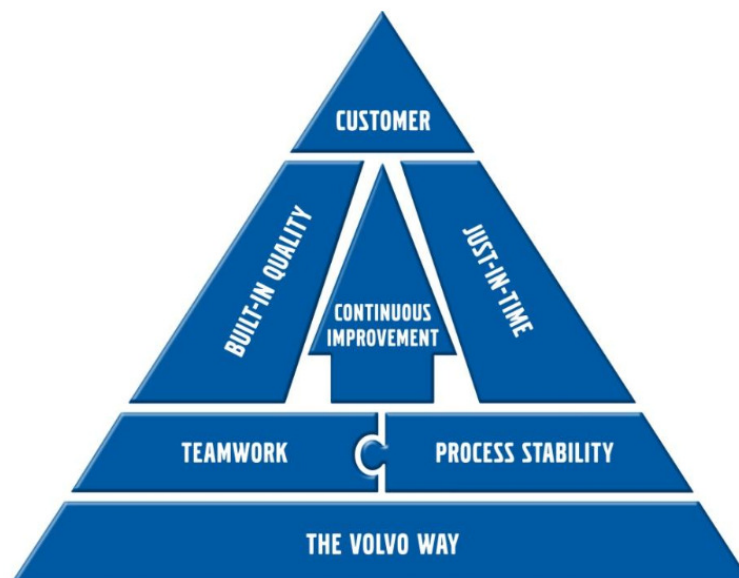

Figure 8: The VPS triangle

In the VPS three major parts are present; visions, principles, and tools and techniques. The “principles” include the VPS triangle elements that are to be followed in order to reach the vision that has been set by Volvo. Tools and techniques are used in the improvement work. An example of tools and techniques used are Plan-Do-Check-Act (PDCA), 5S, flexible production, produce to order and value stream mapping (VSM). The three parts are used in order to improve the quality, eliminate waste and improve the efficiency and to deliver as agreed in right time (Volvo Production System - På väg mot världsklass, 2013).

4.2 Assembly processes

Tuve plant is one of the assembly plants for Volvo Trucks. The plant consists of two main assembly lines and several sub-assemblies. Beside the parts that are manufactured at Tuve Plant, some parts and components are delivered from other Volvo factories or external suppliers e.g. Umeå factory provides the Tuve plant with cabs.

4.2.1 Factory Layout

The factory in Tuve consists of two main assembly lines, line 21 and line 22, as well as several sub-assemblies which provide the material and components to the main assembly line. Beside of these there are some working areas after the final assembly line dedicated to final quality control and further customer adaption if it's required.

4.2.2 Main Assembly Line

The driven assembly line was introduced at Tuve plant in 2009. Before that, automated guided vehicles (AGV) were used to transport the truck between the stations in a stop-and-go motion through the assembly line. The assembly process started with axles being put on AGVs which went through a number of stations where other parts were mounted until the truck was finished and possible to drive. A drawback with this system was the high waiting times between each station when the operators were waiting for AGVs to enter. The driven line was introduced in order to reduce the waiting times and increase productivity.

As mentioned earlier, today there are two main driven assembly lines at Tuve, line 21 and line 22. Driven line 21 consists of 28 stations and driven line 22 of 25 stations. The lines are well equipped and have the ability to be used for producing any type of truck that today is produced in the Tuve factory plant.

The new truck model, FH, is produced at line 22 where the other series are produced at line 21. Each main assembly line has their respective sub-assemblies. As there is significant variations between different trucks there are also variations in operations times at the different stations for each truck.

The main assembly lines are balanced with max-balancing. Max-balancing means that the main assembly lines have been balanced according to the most time-consuming variant.

4.2.3 Sub assembly lines

Today Tuve plant includes several sub-assemblies which are followed by the two main assembly lines. These sub-assemblies are producing parts such as air-tank, valves, and battery boxes. In the sub-assemblies preparatory work are carried out, such as preparing major parts as axles, engines and mufflers.

4.2.4 After the main assembly

When a truck rolls out of the main assembly line it enters a control station. The truck goes through different tests and if there is any problem it will be send to an adjustment area in order to get fixed. After that, the truck will go through some extra stations if the customer has demanded special equipment which could not be done in the line. After this, the truck is ready to be delivered to customer.

4.3 Product variety at Tuve

At Tuve plant, FH, FH16, FM and FMX truck series are produced. All these series can be produced with different type of engines, chassis, cabs, axles etc. These examples are just major parts but the variation can also come from smaller parts and components such as the

battery box and different cab colors. This means that almost every truck produced in Tuve is unique and differ from the other ones to some extent.

4.4 Databases

There are plenty of databases used at Volvo today. Databases related to this project are Sprint and CSO.

Sprint

Sprint is an abbreviation for **integrated production system** and is a global manufacturing system developed in-house by Volvo IT. Sprint is a tool to deliver quality assured production structure to the assembly process [Volvos intranet]. Sprint is used to create assembly instructions and material handling instructions for every truck.

All the work tasks for all of the variants are present in Sprint as core instructions (CI: s). A CI is a number e.g. 90366 with an included description e.g. “Read mounting instructions”. One truck has approximately 2500 CI: s where 700 are located in the main assembly line. Data in sprint is presented in a hierarchical way, illustrated in figure 9.

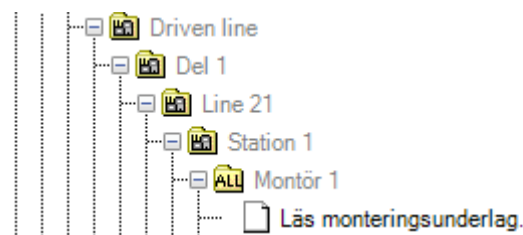

Figure 9: Schematic overview of hierarchical library in Sprint

Connected to the majority of the CI: s are function groups. As a CI is a random number and doesn't necessarily tell what part of the truck the specific CI belongs to, the function groups may be of guidance. The description of the CI:s usually includes abbreviations' so the function groups help to understand the meaning of the CI:s. Examples of function groups are “powertrain unit” and “battery box”. Beside the function groups, time studies have been done and are connected to almost every CI.

CSO

CSO (Chassis Sequence Optimiser) is an application used to form a production sequence. It also includes the total cycle times for all the operators that work on a specific truck (tasks and task times in detail exist in SPRINT). CSO takes its cycle times from Sprint.

5. Implementation

This chapter aims to give the reader a possibility to follow how the study has been carried out. As shown in the method chapter and illustrated in figure 10, this thesis has been divided into three main phases. The implementation of the two first phases, pre-study and simulation study will be described here. The last step, analysis of results, is described in the next chapter in more detail.

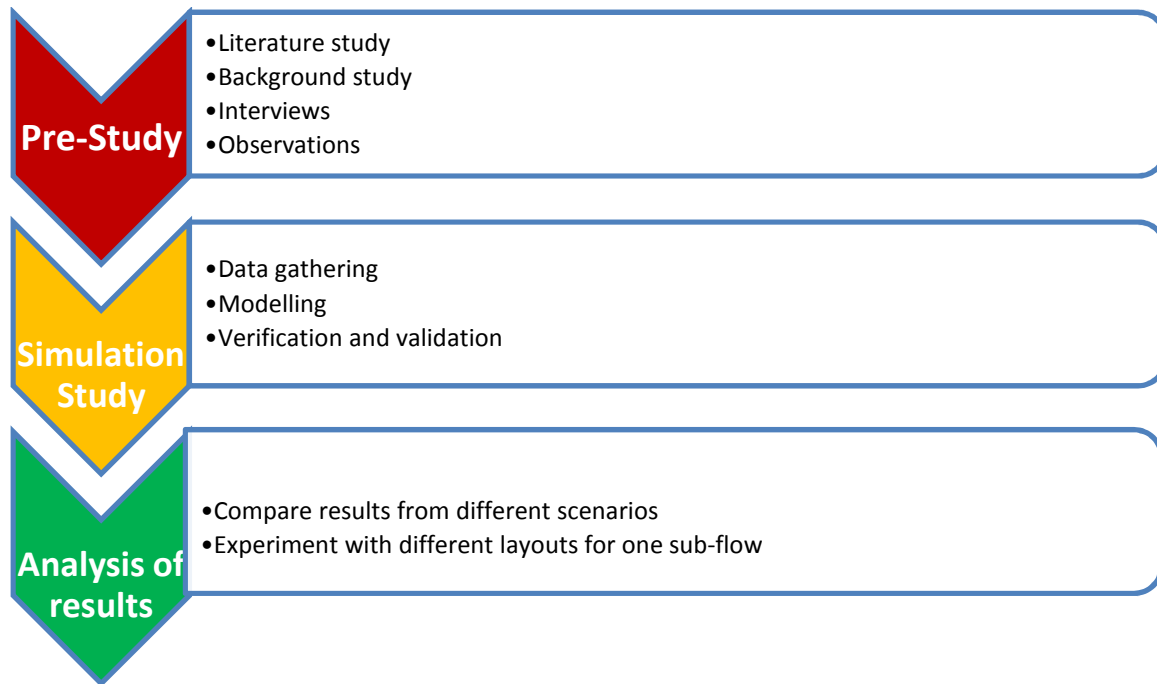

Figure 10: Implementation guidelines

The pre-study phase aims to give a better understanding of the Volvo production system as well as knowledge about challenges in balancing losses in an assembly line as well as FFC. The simulation study has been carried out in order to find the line balance efficiency in the current assembly lines and an estimation of line balance efficiency in the future factory assembly.

5.1 Pre-study

The pre-study has been carried out in four different ways and aimed to give required knowledge about the system under investigation and theory related to this study. Literature study has been done to study the relevant theory to this master thesis. The background study, as well as observations and interviews, has been made in order to learn more about the assembly system at Volvo and FFC. The results of them were used when doing the simulation study and parts of these results are presented in the case description chapter.

5.1.1 Literature study

The main purpose of this study was to investigate how the line balance efficiency (LBE) will change by implementing a fishbone layout. Therefore, it was necessary to study factors that affect the balance efficiency of an assembly line. The starting point has been to review the elements and different types of an assembly process. Later on, based on the Volvo products

which are highly customized trucks, the assembly line with mixed-model and customized product has been studied. As the studies show the balance losses and improving the line balance efficiency is a big challenge in the mixed-model assembly systems (Rachamadugu and Talbot 1991, Ghosh and Gagnon 1989). In the following the modularization concept has been named as a solution for eliminating the customization's drawbacks (AlGeddawy and ElMaraghy 2013, Pandremenos 2009). It was essential to study theory regarding the production systems which face the same challenges as Volvo in case of improving LBE. Further literature studies have been done to find out how the balance efficiency can be calculated in an assembly line similar to Volvos. The results of the literature study have been presented in the theory chapter.

5.1.2 Interviews

As the literature study gave general knowledge about the assembly process and its elements and challenges, it was necessary to get knowledge about the actual assembly process at Volvo. The interview was a tool that could help to get this knowledge. The interviews supposed to provide knowledge regarding the main subjects;

1. Volvo assembly system

This subject included the assembly system at Tuve and its challenges, the level of product variation and customization, and modularization.

2. Future Factory concept

Interviews regarding FFC helped to understand the meaning of the concept and how it will change the assembly process at Volvo.

3. Internal data bases

Interviews with Volvo's experts have been done in order to find the relevant data bases and their contents.

The first few interviewees were suggested by the supervisor of this study. These interviews gave information about the above subjects as well as names of experts in the respective fields. Interviews with production engineers at Tuve had to be excluded due to their tight time schedule.

There is a continuous activity trying to decrease the balance losses but the high product variety with following time variations makes this harder. The high level of customization makes each truck produced by Volvo almost unique with variations in tasks and total task time. Besides the daily efforts balancing the line and optimizing the production sequence the need of a major change has been considered. This major change has been defined as the Future Factory Concept which is a vision for improving the assembly process. The FFC suggests a high product and production modularization in a fishbone-layout. The interviews also showed that there is different understanding regarding the FFC and modularization, where some think the new model is produced completely modularized where others see how much that's still left. As a result of interviews with experts and data system owners Sprint has been considered as the best source of data. It includes all tasks and task times for each product variant. It also led to find the relevant data and documentation which is described in the next sub-chapter.

5.2 Simulation study

The simulation was the chosen method for calculating the line balance efficiency in both current situation and in FFC. A part of the Banks methodology, presented in method chapter, has been followed to accomplish the simulation study. Here, four main steps; data gathering, model building, verification and validation, are described in detail.

5.2.1 Data gathering and management

In order to make the simulation models, both data to build the models and to run the models were required. Data to build the model in this study included assembly system data such as number of stations and operators. The data to run the models consisted of production sequence and cycle time of each operator related to the product variant. After finding and collecting data, it was required to transform and manage the data in a format that was usable by the models.

5.2.1.1 Data gathering

As the purpose of this study was to investigate how the LBE will be affected by implementing FFC it was necessary to build a simulation model of the FFC and calculate the LBE. One of the reasons for choosing the simulation study as the method for this study was to make it possible to study the actual product variants in the production. The product variants differ in term of task and task-time. The result of a model that could run all the product variety would stand more close to reality than a study which cover just some chosen variants.

Data regarding the FFC has been collected by doing interviews and finding relevant documents. The documents showed that the FFC consists of 19 different sub-flows which each feed the main assembly line (MAL) with a complete module. All parts and components that form a module have been already defined clearly in the documents. In the other hand, the FFC has not been completely implemented yet and required tasks for making each module were not defined which means that there is no estimation of the total task times in each sub-flow. This led to a simulation study where the data are not available neither collectable. As Skoogh and Johansson (2008) mentions, in such a case estimations is a way of providing data.

Discussions with the supervisor of this study concluded that tasks and task-times currently carried out in the main line should be re-assigned to the relevant sub-flow. However, it will not be the exact tasks and task-times that will be carried out in the FFC but it's the closest assumption for making this model. For implementing the FFC some re-design of the components might be necessary which will also affect the required task in the assembly process. However, using the current tasks and task-times has been found as a most reliable assumption for using as input data.

As stated in the *case description chapter* each task in SPRINT is named as a core instruction (CI). Example of CI has been presented in the *case description chapter*. It is possible to see all the CI:s for each operator and each station and the required time for performing them in SPRINT. To find the most feasible way to gather the required data to build and run the simulation model, the system owner for SPRINT has been interviewed. All the CI:s performed in the driven assembly line for all possible type of product variants have been

extracted from SPRINT by its system owner. In the next step it has been decided that two weeks production includes sufficient product variety is enough for using as input data to run the simulation model. 10 days production data has been extracted from sprint which includes the 18th of Mars to 3rd of April. The data included 716 trucks and all their CI:s in the both driven assembly lines.

5.2.1.2 Data management

In order to use the data in the model it had to be managed and transformed in a usable format and structure. It was required to know what sub-flow each CI should be assigned to. In the FFC all CI:s will be assigned to their relevant sub-flow or will remain in the MAL if the CI is for mounting a module.

The data management started with excluding the irrelevant CI:s. those CI:s could belong to the quality checking or any station out of the models boundary. The model was supposed to cover main assembly lines which start from station 14 to dyno-station (Stations 1-13 produce chassis). This data management could be done by more specified inquiry during the data extraction from SPRINT but in the same time it was not time consuming to doing that manually afterward. After excluding irrelevant CI:s, approximately 2300 unique CI:s remained.

The most time consuming part of data management was to assign the 2300 remaining CI:s to the right sub-flow. Around 70 percent of these CI:s had an attached Function-Group (FG) number in SPRINT. By use of these FG numbers and an internal Volvo document it was possible to trace major part of the CI:s. the CI:s without the FG numbers and those who had the FG number but the FG number was not represented in the document left to be assigned by other method. These CI: s, approximately 500 CI:s, were assigned together with experts in the field.

After transforming and managing the Unique CI: s, the 2 weeks production data needed to be sorted and transformed. This data was closely to 1 million CI: s and included some quality tasks and tasks which belonged to stations out of the project interest. All the data has been sorted and structured in two separate worksheets, one for each line.

The initiate though was to use the CSO database for supplying the input data to the simulation model of current driven assembly lines. The CSO data includes the total cycle time for each operator/each variant. Due to the high workload for CSO's system owners, it has been decided to use the Sprint data for current situation model also. Although the CSO is connected to SPRINT and gather its data from SPRINT, using the SPRINT data caused more workload to this study.

5.2.2 Model building

The simulation model has been suggested and chosen as a suitable method for accomplishing this study. The model was supposed to cover the FFC in the level of detail which was sufficient to calculate the line balance efficiency (LBE). In order to reach the purpose of this study, it was necessary and required to compare the level of LBE in FFC with the same

parameter in the current situation. Simulation models would thus make it possible to do the comparison and find out how the LBE will change by implementing FFC.

For making these simulation models, Tecnomatix plant simulation software was used. For calculating the LBE in FFC two separate models have been created where each of them represents one of the assembly lines (Line 21 and Line 22). In respect to each of those models, one simulation model has been built to cover the current situation. At the end one of the sub-flows in the FFC has been modeled separately in order to test another layout instead of a line layout. Totally five model has been made with a big focus on flexibility and user-friendly.

It has been discussed earlier in the previous sub-chapter (data) that the input data for the FFC model was mostly based on assumptions. For making it possible to change the model in the future and use more accurate input data, the models have been created with big focus on easy-to-change and inheritance function has been used as much as it was possible. The data has been kept separate from the coding which will make it easier in the future to just change the content of the data tables without any needs to change the codes. Following are descriptions of all the models in more detail.

5.2.2.1 Current situation model

Two simulation models have been built where each of them represent one of the driven final assembly line at Tuve plant. These two models are in the operator level and are able to consider the cycle time for each operator per each product variant. As it has been declared in previous sub-chapter the model starts working by finding all the CI:s which belong to each operator and add them together to transform them to a single cycle time for each operator. After that through the running the LBE for each product variant calculates. The data have been kept separate from the model coding which make it possible to use production data for other time periods easily. The following are all the assumptions and elements of the current situation simulation model.

- The simulation model starts from station 14 and cover all the stations up till dyno.
- The quality tasks (quality operators) have been excluded from the model. The reason was to follow the same structure and assumption in both FFC and current situation models.
- The models have the same takt-time as in Sprint. As all the data has been extracted from Sprint and no time study have been done, it has been decided to also pace the line with the takt time that exists in Sprint.
- In the model it was assumed that both lines produce at full capacity, whereas in reality capacity utilization may vary over time

These were the assumption in the simulation model of the current situation. The output of the model is a table that includes all the product variants (Chassis Number) and their LBE value. These two models have been made by more accurate data and less assumption compared with the models covering FFC. An illustration of the simulation model for line 21 is presented in figure 11.

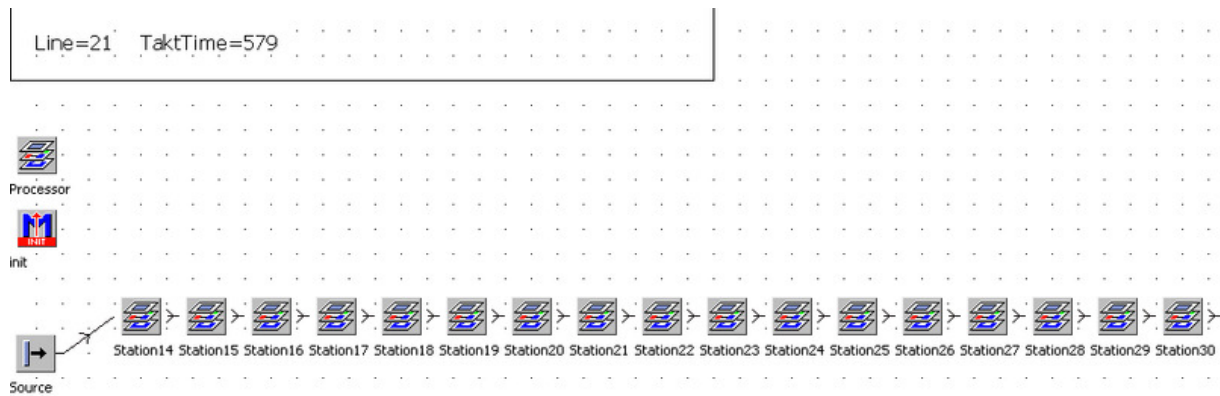

Figure 11: Print screen over line 21 simulation model (current situation)

5.2.2.2 FFC models

Two simulation models have been created in order to calculate the LBE in the Future Factory Concept. The structures of these two models are very similar and include one main line and 18 sub-flows which together create a fishbone layout. Each sub-flow, or in a better word, each conceptual sub-assembly line (CSAL) is the place for creating one of the 18 modules. At the end of each CSAL the module mounts on the Truck. For crating the models some assumptions have been made which directly affect the output of the model. In order to be able to rely on the output of the model and having an estimation of how these outputs may vary in the future it is essential to consider the assumption and the structure of the model. The following are all the assumptions and elements of the FFC simulation model.

- The CSALs in the model represent conceptual assembly areas which do not exist currently. It has been assumed that they are lines or stations which connect the existed sub-assemblies to the main assembly line in the future. E.g. the CSAL for power train unit is a line that is fed by engine line in current factory and the output of that will be the complete power train unit module. In the future factory this CSAL might be just few stations at the end of engine line and the tasks of that might split between all the stations in the engine line.
- The table of unique CI:s which has been divided to different CSAL(described in 5.2.1.2), uses as the reference for dividing the CI:S of each chassis number to the relevant CSAL. It will lead to one specific “production order” for each CSAL. Each “production order” includes all the Chassis number in the same sequence but have just respective CI:s which supposed to be carried in that CSAL. It will help to find the minimum, average and maximum of total cycle-time for each CSAL. By this total cycle-time it is possible to calculate target manpower.
- In this model, the main assembly line in the FFC (MAL) includes 18 stations with same takt-time as the current one. Each station has 2 operators who have the same amount of tasks for all product variants as it is the idea with the FFC. The BLE in the MAL has been considered 100 percent.
- To be able to make the comparison between FFC and current situation, the takt-time and the line output in the FFC have been considered as same as the current situation.
- The CSAL are averaged balanced based on the average of total cycle-time in each CSAL. However the model can and did also consider the maximum balanced option

for the CSALs. Using average balancing means that the time is the time needed to complete a truck with most average workload, where maximum balance is the time needed to complete the most time-consuming variant. This applies both to the FFC-model as well as the current situation model.

Points that have been described above were all the assumptions that have been made for creating the FFC simulation model. An illustration of the FFC model is presented in figure 12.

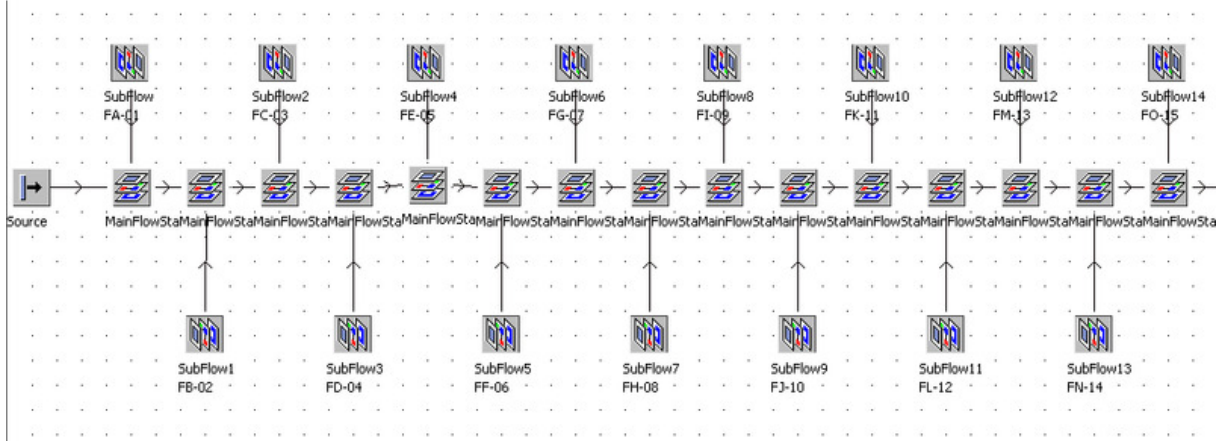

Figure 12: Print screen of FFC simulation model

The model calculates the LBE for each CSAL and as the result for each specific product variant (Chassis Number) there will be 18 different LBE. This number will reach to 19 LBE if the LBE in the MAL is taken into consideration. These LBE:s are good indicators to understand the variation of the product variety in each module. But it is not possible to compare 19 different LBE to one single LBE in the current situation. In order to solve this issue these 19 LBE:s have been transformed to a single LBE which represent the LBE of entire FFC model.

In order to transform 19 LBE:s to a single number, each LBE has been weighted by the number of operators who work in the respective CSAL and then the average of them has been used as the LBE of the FFC. Two LBE value has been calculated for each FFC. The first one is the average of the 18 CSAL and the second one includes also the value for the main assembly line.

5.2.2.3 Rear Axle sub-flow

In FFC simulation model all the sub-flows have been consider as “Line” which made them to be called Conceptual Sub-Assembly Line. As it has been described in the theory chapter the assembly can be organized in other structure than Line. To examine how much the structure might affect the efficiency of the assembly process, the sub-flow for rear axle has been modeled as parallel stations. An illustration of the rear axle sub-flow with parallel station layout is presented in figure 13. The reason for choosing the rear axle was high variation between the CI: s for any product variants. Based on the results of FFC model, all the 18 sub-

flows has been studied. The rear axle sub-flow has highest standard deviation which made it good candidate for this examination.

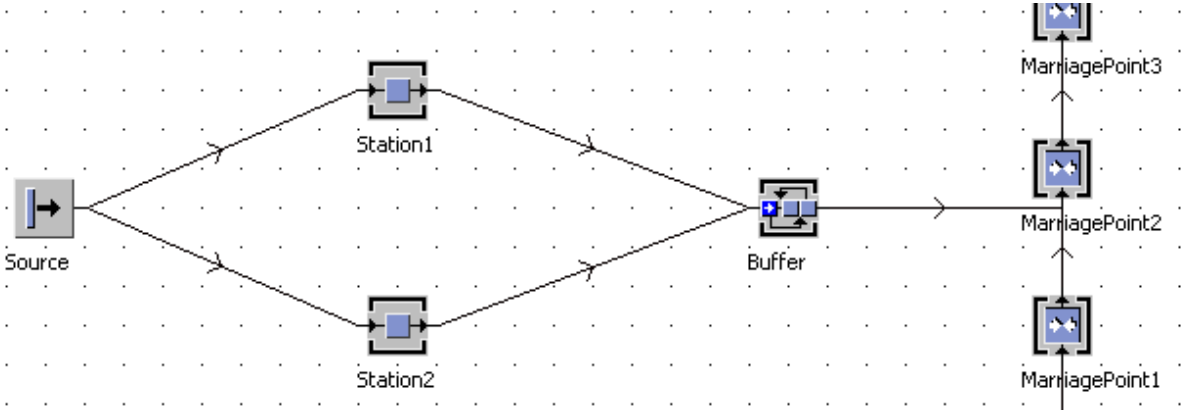

Figure 13: Print screen of rear axle sub-flow with parallel station layout

The input data for this model are from the FFC model. It includes all the variants (Chassis Number) and the respective CI:s which belong to the rear axle sub-flow in the FFC. The model consists of two parallel assembly stations where each of them is responsible for creating a complete rear axle module. The following are all the assumptions and elements of the rear axle simulation model.

- Based on the output of the FFC model the rear axle sub-flow needs five operators when it is average balanced. The same number of operator has been also used in this model with more flexibility. It means each station has two fixed operator and one operator works as an extra operator when the product variant has higher tasks time in total.
- Unlike the FFC and current situation models, these two stations do not have any takt time and they work until a complete rear axle module is ready.
- A buffer has been considered between rear axle sub-flow and the MAL. As the sub-flow is not paced with the same takt-time as MAL, the buffer is necessary to eliminate the material shortages in the point of use.
- The MAL is still paced with the same takt-time as the other simulation models.

The results of this model are presented in the next chapter.

5.2.2.4 Level of modularization

The results from the interviews indicated that there is a need for more a common understanding of what FFC is and in which extend it is possible to achieve. It also showed different views regarding the extent of modularization that has been reached in the factory. However, it was not one of the initial goals of this study but having the data available led to doing this experiment. In the data extracted from Sprint for line 21, chassis line (stations 1-13) data was included. Therefore, it was considered beneficial to use these data and compare them with the result of the FFC models. The level of modularization can be considered as a useful KPI to measure to what extent the production is actually modularized regarding the future factory concept. This was a new KPI, introduced by the authors of this study, which was received with great enthusiasm within Volvo.

This KPI can be calculated for all the sub-assemblies. Here in this study as an example the level of modularization for the “*base-module*” was calculated with the formula presented in equation 2. “Current spent time for module” is the sum of task times in station 1-13 in today production. “Required time for complete module” is the amount of time it takes to build the module according to FFC. This KPI shows how many percent of the time (tasks) that is needed to complete a module is spend in the relevant sub-assembly in today production. As an example if the level of modularization is calculated to be 85% it means that in that sub-assembly only 85% of the module is built and the rest of that module is completed on the main assembly line.

$$\text{Level of modularization} = \frac{\text{current spent time for module}}{\text{required time for complete module}}$$

Equation 2: Level of modularization formula

5.2.3 Verification and validation

The current situation models have been verified during the coding phase as well as when the models were finished. The behavior of the models corresponded to the real system and the models were considered to be verified. The models covering the current situation have been validated with the help of the experts in Volvo by presenting the LBE value for each line to them. The LBE-values of current situation models have been found to be close to what was known by Volvo. The model was also validated by comparing the throughput time values with values in the real system.

The FFC models have been verified continuously during the model building phase. The models have also been verified by controlling the modules’ number at the end of the MAL. All the product variants at the end of the MAL include 18 modules’ numbers which are same to the variant’s chassis number. It ensures that the CSALs and the MAL are synchronized. As these models partly represent a conceptual factory there were no real data to use for validation of the models. Instead, the models have been validated by assuring that they work in extreme circumstances (e.g. very high workload and higher cycle times) and the result of the models fulfilled the expectations.

The rear axle model has been verified by ensuring the correct behavior of the model. In order to verify the model, it was required to make sure that same rear axle number was mounted on the truck. As this model is also not representing an actual system, the validation has only focused to guarantee that the model works in extreme circumstances.

6. Result and analysis

In this chapter, the result of this study will be presented. These results are based on numerical output of the simulation models and calculations. First, the LBE value for current situation and FFC will be presented and later on these two will be compared to each other. The rear axle sub-flow has been modeled as a parallel station layout and its result will be analyzed. At the end, the level of modularization that has been calculated for one of the 18 module will be presented.

6.1 Current Situation

An example of output from the current situation simulation model is shown in table 2. As can be seen in that table the first column presents the product variants with respective Chassis Number. The Chassis Number is unique and can easily be traced back in order to find all details about the product variant. The second column represents the LBE value for respective Chassis Number. The LBE value, as it has been described in previous chapter, just covers the line balance efficiency for product variant through the driven assembly line from station 14 up to dyno. The third column shows number of operators who worked on each specific product. Note that these numbers might differ from the actual number of operators who have actually worked on the product through the driven assembly line. It should be taken into consideration that these numbers present the number of operator who had been assigned for the product in the SPRINT system.

ChassisNr	LineBalanceEfficiency (LBE) %	Number Of Operators
A 744872	67	90
A 744873	67	90
A 744874	77	90
A 744875	70	89
A 744876	69	90

Table 2: Line balance efficiency example from current situation

6.2 FFC

As it has been described in the previous chapter, the FFC simulation model in the first step divides all the CI:s to respective sub-flow table. These tables include all the CI:s that needs to be done in a sub-flow and their respective times. Later on, the content of these tables have been used to find out the minimum, average, and maximum of the total task times for each sub flow. These values have been used for finding the theoretical number of operators (minimum number of required operators based on amount of time divided by takt time) for each sub-flow. This minimum number of required operators has been considered as operator numbers in the model.

6.2.1 FFC with average balancing

By using the data described above, the line balance efficiency has been calculated for each sub-flow with both average-balancing and maximum-balancing. The result was 18 separate LBE values for each single product variant (truck). Examples of some of the sub-flows are illustrated in table 3.

Line Balance Efficiency %					
ChassisNumber	Sub-Flow FA-01	Sub-Flow FB-02	Sub-Flow FC-03	Sub-Flow FD-04	Sub-Flow FE-05
A 744872	103	11	63	43	84
A 744873	83	0	70	53	95
A 744874	110	11	112	92	94

Table 3: LBE values for three trucks in five sub-flows

At the end, these 18 LBE values and LBE value for MAL have been weighted based on the number of operator(s) in the respective sub-flow. This made it possible to reach to one single LBE value for each truck which now is possible to be used for comparison to current situation's result. At the end the average LBE value for the 18 sub-flows was calculated to be 76% in line 21 and 69% in line 22. When also considering the marriage-points in MAL, the LBE values will reach to in average 87% in line 21 and 85% in line 22.

6.2.2 FFC with maximum balancing

The results presented above were based on average balancing. If the sub-flows in FFC models ran with maximum balancing the LBE value for all 18 sub-flows was calculated to be 53% in line 21 and 47% in line 22. If also considering the marriage-points in the MAL the LBE values will increase to be 70% in line 21 and 69% in line 22.

6.2.3 Differences in FFC run with maximum and average balancing

As described above there are differences between LBE values when the sub-flows in FFC models are maximum-balanced or average-balanced. The difference between LBE values for 14 trucks in one of the sub-flows is shown in figure 14.

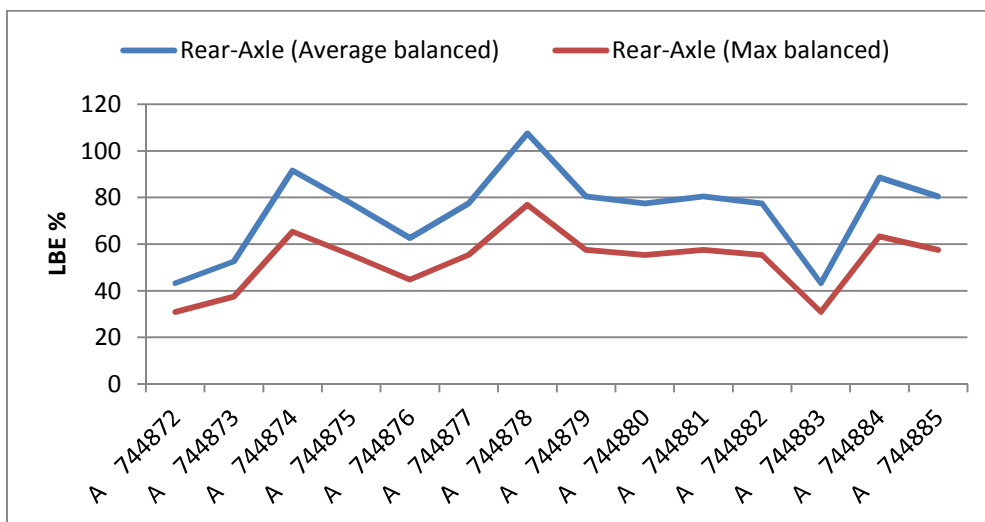

Figure 14: LBE value for 15 trucks in Rear-Axle sub-flow

The difference between these two values is high. The cause of this deviation and also the reason for high fluctuation of LBE values in both max balancing and average balancing can be traced back to the variation of cycle-times in this sub-flow. The total cycle-time varies

between 1000 seconds and 3500 seconds. This huge variation causes the differences between LBE value in average and max-balancing.

6.3 Comparison between FFC and Current situation

In this sub-chapter the result of FFC model, line balance efficiency in FFC model, compares to line balance efficiency in the current situation. In order to make this comparison; first the LBE of FFC, when sub-flows were average balanced, has been compared to the LBE of the current situation. Later on the LBE in FFC and current situation has been compared when the sub-flows in FFC model were max-balanced.

6.3.1 Average balancing for sub-flows in FFC

Table 8 illustrates the LBE value for both FFC and current situation for an amount of different product variants.

ChassisNumber	LBE-Current %	LBE in Sub-flows (FFC)%	LBE in Mal + Sub-flows(FFC)%
A 744872	67	71	84
A 744873	67	70	84
A 744874	77	83	91
A 744875	70	75	86
A 744876	69	73	85

Table 8: LBE values for 5 trucks both in current situation model and FFC model (average balancing)

By looking at the numbers in the table above it can be noticed that LBE values in sub-flows are higher than the LBE values in the current situation. In addition, for comparing the two scenarios, the LBE for same process needs to be compared. Based on that, the LBE value for main assembly line in the FFC also needs to be considered. As it has been described in the previous chapter, the LBE value for MAL is assumed to be 100%. Including this value to the LBE for sub-flows will improve the average LBE value for FFC. The result of the FFC model when it runs with average balancing for sub-flows indicate that LBE value improves for all type of variants by implementing the FFC. This improvement has been illustrated (for 15 trucks) in figure 15.

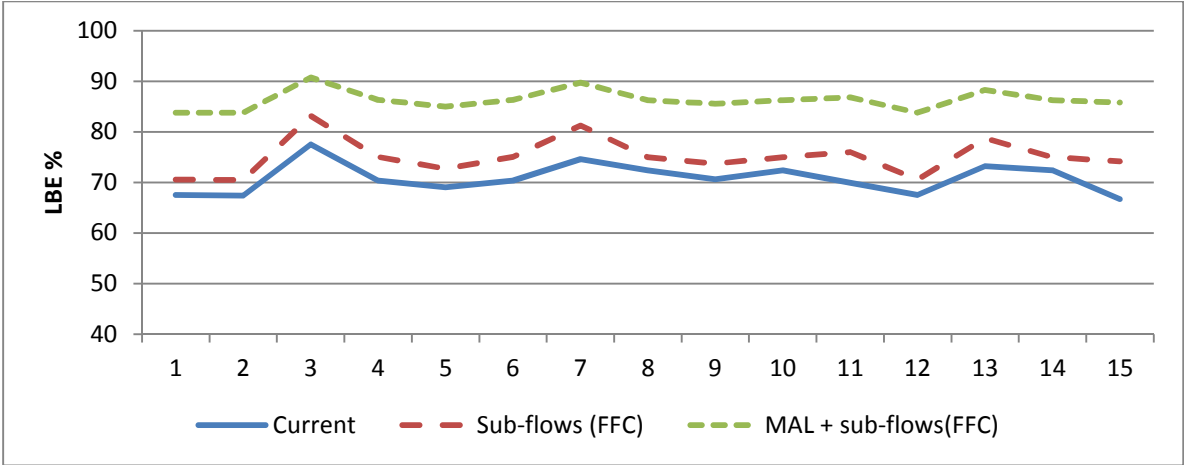

Figure 15: differences between LBE values in current situation model and FFC model (Average balancing)

6.3.2 Maximum balancing for sub-flows in FFC

The result of FFC model when its sub-flows are max-balanced in comparison to the current situation is illustrated in table 9.

ChassisNr	LBE-Current %	LBE in Sub-flows (FFC)%	LBE in MAL+Sub-flows (FFC)%
A 744872	67	49	68
A 744873	67	49	67
A 744874	77	58	73
A 744875	70	52	69
A 744876	69	50	68

Table 9: LBE values for 5 trucks both in current situation model and FFC model (Maximum balancing)

It is clear that average LBE in sub-flows decrease dramatically when the sub-flows are max-balanced. However based on the previous assumption the LBE at MAL is 100% which will increase the LBE at FFC. Beside the positive effect of MAL's LBE the FFC still has almost same LBE value compared to the current situation. The result for 15 product variants is shown in figure 16.

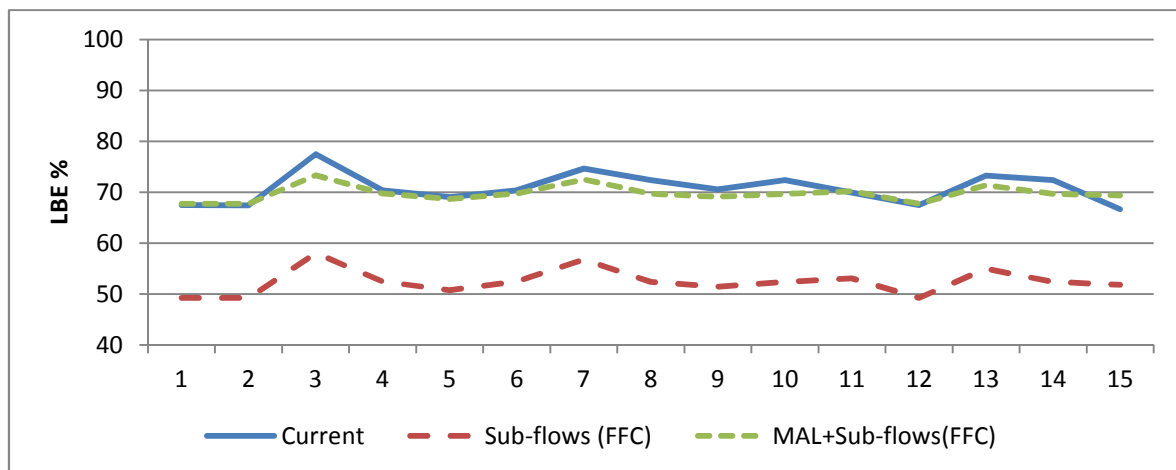

Figure 16: differences between LBE values in current situation model and FFC model (maximum balancing)

The result of this experiment which has been presented in both table 9 and figure 16 indicates that re-assigning the tasks from main assembly line to different sub-flows cannot be helpful by itself. The main improvement in this case has been achieved by getting the possibility for average balancing. It led to focusing more on the possibilities that are created by implementing the FFC. As a result of implementing the FFC, it was possible to test different structures for sub-flows than the line structure. These results and created possibilities will be discussed further in next chapter.

6.4 Rear Axle Sub flow

As it has been described previously, an assembly layout can also be in form of parallel station or line. In the FFC model, one of the assumptions was that sub-flows are in form of lines. In order to examine the effect of different assembly layouts one of the sub-flows has been chosen for experiment. Based on the result of FFC model, the rear axle sub-flow has the highest standard variation and therefore it was a suitable candidate for this experiment. It has been modeled in form of two parallel stations where each of them assembles a complete rear axle module, illustrated in figure 17.

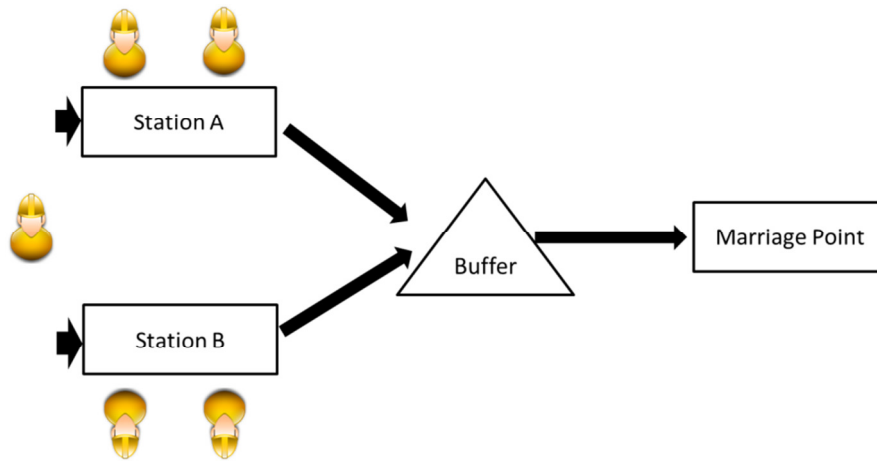

Figure 17: Illustration of parallel station in Rear-Axle sub-flow

As can be seen in the figure above, station A and station B represent those two parallel stations which support the marriage point with complete modules. A marriage point is the station in the main assembly line where the modules are supposed to be assembled on the truck. In order to avoid material shortages in the marriage point, a buffer has been considered. In this model the marriage point has the same takt-time as the main assembly line in the other models.

For making the experiment two scenarios has been examined. In the first scenario, 5 operators work in the rear axle sub-flow. Each of station A and B has two operators. The fifth operator rotates between stations, supporting the station with the highest workload. This number, 5 operators, has been calculated as required number of operators in the rear axle sub flow based on the average balancing. The results of this scenario illustrated in table 10.

In total 5 operators work in both stations								
	Buffer Capacity	Station-A Blocked%	Station-B Blocked%	Station-A Working%	Station-B Working%	Marriage-point waiting%	Marriage-point working%	Buffer Empty%
Exp 01	1	8	14	92	86	16	84	37
Exp 02	2	26	17	74	83	0	100	0
Exp 03	3	26	17	74	83	0	100	0
Exp 04	4	26	17	74	83	0	100	0

Table 10: Results of parallel station layout in rear axle sub-flow

As can be seen in the table above different buffer capacities have been experimented. This experiment can show the required buffer size. Based on the result, a capacity of one is non-adequate to use compared to its effect on material shortages and waiting time for marriage point. As the buffer size should be kept as low as possible, but not lower, a buffer with capacity of two gives the best result. It shows in this example a buffer with very low capacity can avoid any material shortages in the downstream production.

6.5 Current level of modularization

In the previous chapter the definition and formula of level of modularization has been described. As it has been described the data for the chassis line (stations 1-13) was available so the level of modularization has been calculated for this sub-assembly. The average level of modularization in current production for “Chassis line” is calculated to 74%. The variation of this KPI is illustrated in figure 18. As it can be seen the level of modularization for this sub-assembly varies from 68% to 82% depending on what product variant are assembled.

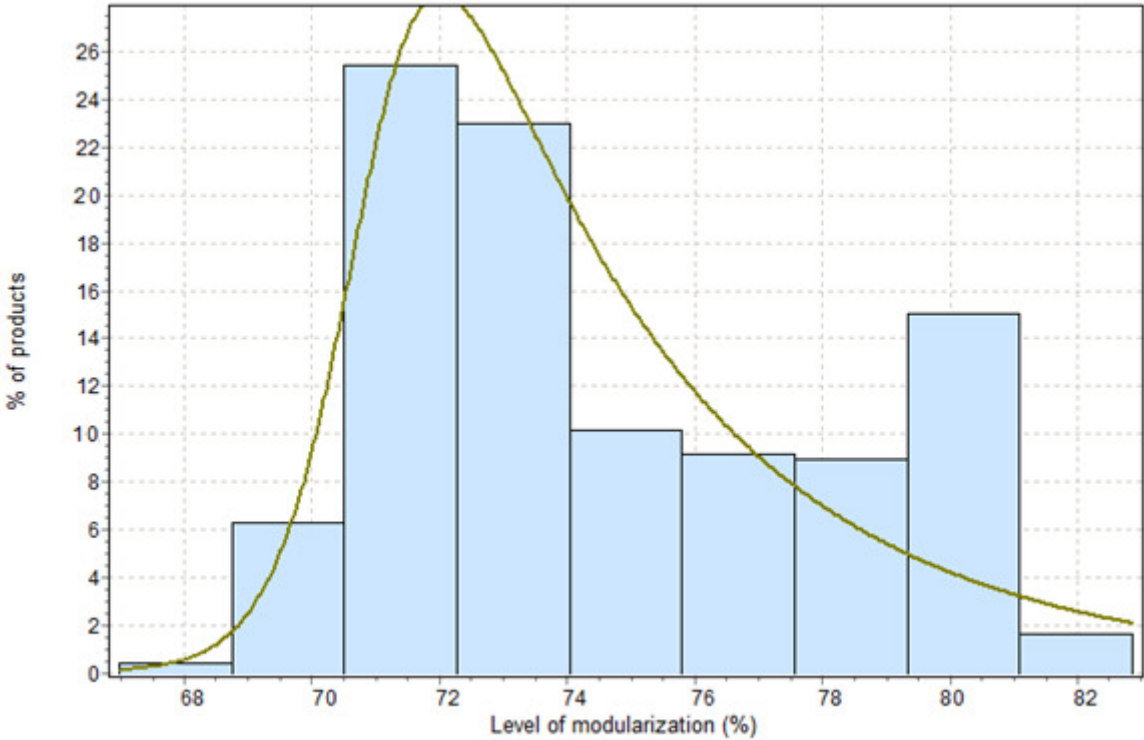

Figure 18: level of modularization for "base module"

7. Discussion

The project aimed to study the changes in line balance efficiency by implementing a new concept called Future Factory Concept (FFC). As described in the introduction chapter, the FFC will cover different aspects of the manufacturing system. This study focused on the changes in layout for the final assembly line (fishbone factory layout) and how the tasks will be assigned to different fish-bones instead of being performed at the main assembly line. With help of different simulation models the results of line balance efficiency in both current factory layout and also FFC have been calculated. These results have been presented in the previous chapter. An alternative option for the structure of fish-bones which initially was considered to be line-structure has been considered. As an option, parallel station structure has been chosen instead of serial line structure. The results of all these models have been presented and analyzed in some extent in the previous chapter. Here, these results will be discussed in a more general perspective and they will be compared to findings from the literature study. Then, the reliability of the results, by considering the assumptions and limitations of the model, will be discussed. At the end, possibilities created from this modularization approach will be discussed and suggestions for future considerations will be given.

7.1 Findings

The line balance efficiency (LBE) value for the current situation has been presented in the previous chapter. The line balance efficiency was lower than 100% due to differentiations between cycle times for operators and takt time. As described in theory, failing to give cycle times for operators same as the takt time will lead to balance losses. These balance losses are also dependent on the different variants in a mixed-model assembly line.

As described earlier in the report, the main assembly lines are currently maximum-balanced. This will give the possibility to finish the heavy variants product in the available amount of time. However, it will bring balance efficiency losses during the assembly of lighter variants. It would be possible to eliminate the balance efficiency losses to a large extent if the tasks and task times for all the variants were the same in the assembly lines. This means having tasks and task times independent to the type of variant.

The FFC try to make it possible by eliminating the variety of different tasks from main assembly lines. These tasks are supposed to be re-assigned to different sub-flows where complete modules will be created. This will leave the mounting of modules in the assembly lines which will be independent to the variants and always takes same amount of time. Based on this concept a model has been created. The FFC simulation model shows high improvement in the line balance efficiency. In this model all the tasks in MAL has been moved out to the sub-flows except the tasks for mounting the complete modules. The sub-flows have been average balanced and are structured in line layouts. For line 21, the result shows 6 percent improvement in the line balance efficiency in sub-flows. By considering the LBE for main assembly line in the FFC model, this improvement will reach to 22 percent and the final LBE for FFC model will be 87% in average.

When the sub-flows are average balanced, the LBE value will exceed 100% for variants with longer tasks-time than the average value. This means that the product variants will not be finished by available resources and extra operator(s) or time is needed. The solution might be maximum-balancing the sub-flows or improved sequencing or extra operators. Two of these options, maximum-balancing and sequencing have been discussed in the following sub-chapters. Using more time has not been discussed due to the fact that the assembly system is paced and any stoppages will affect the rest of the sub-flows and the main assembly line.

7.1.1 Maximum-balancing

As the FFC models are designed without any buffers, delays from any of the sub-flows will cause losses for the entire system. If the delay occurs due to the average balancing in the sub-flows it might be necessary to consider maximum-balancing for sub-flows also. The results of FFC model with max-balancing have been presented in the previous chapter. Considering just the sub-flows, the LBE value has been decreased dramatically by 26 %compare to the LBE value in the current situation. If adding the improvement of LBE in the MAL, the average LBE value for FFC will come very close to the current situation's value but without any improvements.

The reason for this significant decrease in LBE when the sub-flows are max-balanced can be traced back to the high variation in the task-times for different variants. The same problem that is in the current situation has been moved to the sub-flows. The result of the FFC models, presented in the previous chapter, indicates the high tasks time variation for different module in a sub-flow. The FFC models showed two completely different results depending on how the sub-flows were balanced, maximum-balanced or average-balanced. This indicates that using the modularization thinking and re-assigning the tasks to the sub-flow will not be helpful by it-self for eliminating the balance losses. It is more helpful by giving different opportunities to handle each sub-flow. As the first opportunity given by FFC, the sub-flows in the FFC have been average balanced, as same as the existing sub-assemblies in the factory today. The result of this average balancing was good improvement in the balance efficiency compared to current situation.

7.1.2 Sequencing

The other common solution for a mixed-model assembly line is to focus on improved production sequencing. Each sub-flows in the FFC roles as a mixed-model assembly line for itself. The limitation in this fish-bone layout is that the sequencing solution cannot be implemented for all the sub-flows. The reason is that when the production sequence for one of the sub-flow has been set the rest of the sub-flows have to use the same sequence. It would be possible to focus on the sub-flow, which any changes on it, has the biggest impact on the total LBE in FFC. It will still not guarantee that the rest of the sub-flows have also the optimal production sequence.

7.1.3 Different layout

As an option for sub-flow that is less dependent to the sequence and does not experience same problem with average- or maximum-balancing, one of the sub-flows has been considered having a different layout. The parallel station has been chosen as the layout for one of the sub-

flows. By implementing the parallel station layout, each station will continue to work on the module until the module is completely finished. As a result, there will be no problem with exceeding the takt-time. As the processing time might not be the same as the takt-time in the MAL, a buffer is needed to ensure that the MAL does not suffer from material shortages. As presented before, the buffer capacity does not need to be high and with just a capacity of two modules the material shortages will be eliminated. On the other hand this layout does not need more operators than the number of operators in the sub-flow with average balanced line.

As it has been presented in the theory chapter, many researchers name modularity as a solution to handle the drawbacks of having customization and product variants. The FFC also rely highly on the concept of modularity. The results of this study, presented and discussed earlier, indicates that the FFC can have both positive and negative affect on the line balance efficiency. As it presented the line balance efficiency decreased in some sub-flows but in general and by considering the whole model the line balance efficiency in the worst case was as same as today. The results indicate that success of FFC relies on how the sub-flows are managed. One of the most important effects of the FFC is the possibility of having different approach for organizing and managing each sub-flow. It will make the assembly system more flexible and instead of just following one type of structure and rules for all of sub-flows, they can be managed in different ways. It should also be considered that having less tasks in a sub-flow will make it much easier to handle that sub-flow. In a fishbone layout without any buffer, the whole system will be dependent to each other. E.g. any stoppage in one sub-flow will cause losses in term of waiting or blocked time in the rest of the system. A more flexible fish-bone layout where each “bone” can have its specific layout and be connected to the main line with a buffer will decrease the dependency which leads to fewer losses.

7.2 Limitation and consideration

The results of the models have been presented and discussed. It should be mentioned again that all the output of a simulation model relies on its input data. In the input data and during the models building some assumptions have been made. For making any judgment based on the results of this study, first the assumptions should be taken in to consideration.

In this FFC model the sub-flows were separated from the existing assembly lines. As it described in (5.2.2.2) the sub-flows just contain the tasks that have been re-allocated from the main assembly lines (driven lines). Some differences might occur if these sub-flows are instead considered as additional station(s) in the existing sub-assemblies. For some of the sub-flows which have just few tasks it might be helpful to adding them to the existing sub-flows. On the other hand, for some of the sub-flows with high amount of tasks, it might lead to complexity in the existing sub-assemblies if they are merged together.

It needs to be considered that the results of this study are based on a single case study at Volvo Trucks in Tuve. As presented in the result-chapter, the line balance efficiency varies in line 21 and line 22 and also in each sub-flow. This points out that the results are completely dependent on the nature of the tasks in each main assembly line and sub-flow. In a general view, it can be concluded that the results of this method is dependent on the type of products, product variations and amount of tasks. However, it is still arguable that the implementation

of such a concept will give the possibility to manage and organize the different sub-flows with different approaches.

7.3 Sustainability

Sustainability focuses on three areas, economic, social, and environmental sustainability. This study is more connected and in help to two first areas, economic sustainability and social sustainability. However as the result of this study pointed, it is possible to decrease balancing losses and lead time which will decrease the use of different type of resources and energy consumption. This saving would lead to more environmental sustainable production indeed.

The economic sustainability will be achieved by decreasing the balancing losses. Decreasing the balancing losses can lead to producing same amount of products in less time or with less manpower. It will help Volvo to stay competitive in the market by having more economic sustainable production. Reaching to a complete modularized product and production will help to use the right resources at the right place. It also give the possibility of outsourcing some modules and benefits from economy of scale. Regarding the tools used in this study, simulation is to great help to study the behavior of a future system including all type of product variants. This gives the possibility to gain better prediction of the future factory concept and avoid the trial and error method which can be very costly.

Regarding the social sustainability it is obvious that when Volvo reach the economic sustainability it will have positive social affect both on Volvo employees and the community. The community can benefit from keeping Volvo's production plant in Sweden. Hackman and Oldham (1976) presents the job meaningfulness and responsibility as two important factors which lead to higher motivation and performance of the workers. In the FFC, fewer workers are responsible for assembling a module and will therefore experience a higher responsibility for the outcomes. This in itself could lead to higher quality and performance and give the workers an increase in the feeling of meaningfulness of their job, a positive psychosocial effect.

Finally this study helped to predict the results of implementing the FFC concept regarding the balance losses. As a possible alternative layout for one of the bones (rear axle sub-flow) has been presented in section 5.2.23 and 6.4, this study helps to consider other possible alternative which might lead to higher economic and social sustainability.

7.4 Possibilities and recommendations

This study and its models do not cover all the aspects of modularization and FFC. This concept might for example, also lead to quality improvements and benefits in internal material handling. It also creates the possibility to outsource complete modules. All of these can be lead to success of the factory by achieving the economical sustainability. It can be argued that product design and achieving the modularity of design will be difficult and costly. But as a suggestion for further investigation this costs and difficulties can be compare to the saving and gaining from more sustainable production.

8. Conclusions

In this chapter the findings of the study are summarized and that/how this study answered the research question is described. Finally, recommendations for future studies in this area have been presented.

The purpose of this study was to examine how an introduction of fishbone layout and modularized production (FFC) will affect the line balance efficiency at Volvo Trucks Tuve. The result of this study, based on defined assumptions, shows that implementing a fishbone layout has no negative impact on the line balance efficiency in the Tuve plant. In order to accomplish this study, two final assembly lines at Tuve have been simulated based on the current layout and data. The line balance efficiency for these two lines has been calculated. Later, all the tasks currently done in these two main assembly lines have been studied and divided to the sub-flows proposed by FFC. Two more simulation models have been built which cover FFC and use the divided tasks and their times. These two models helped to calculate the line balance efficiency for a situation where FFC has been implemented.

At the end, the results of the simulation model for current situation and FFC situation have been compared and analyzed. The result shows no decrease in LBE by implementing the fishbone layout and modularized production. It also indicates that improvements in line balance efficiency can be achieved dependent on how the fish bones are organized and managed. This study shows that considering a different layout than serial line layout for fish bones can assist in avoiding the challenges regarding line balancing and sequencing.

In addition to the initial goals, a key performance indicator (KPI), level of modularization, has been introduced. This KPI has been calculated for one of the fish bones and indicates how far the modularization work has reached in today production at Tuve plant. This KPI has been recommended to be used in order to continuously follow up the level of modularization in the factory.

For future studies, further investigations regarding the impact of FFC on quality are recommended. Another interesting area for further investigation is to study the possible improvement in line balance efficiency by merging the FFC model's sub-flows with the existing sub-assemblies. It is also beneficial to investigate the cost of product re-design and changes in layout. By investigating these areas the cost of implementing the fishbone factory can be compared to the savings of the implementation.

9. References

AlGeddawy, T., ElMaraghy, H. (2013), Reactive design methodology for product family platforms, modularity and parts integration, *CIRP Journal of Manufacturing Science and Technology*6 (1), pp. 34-43

Andersson, J., (2011), Lecture: Line balancing, Production system course, Chalmers University of Technology

Banks, J., Carson, J.S., Nelson, B.L., Nicol, D.M. (2010), *Discrete-Event System Simulation*. 5th ed. Upper Saddle River, New Jersey: Prentice-Hall, Inc.

Banks, J., Carson, J. S., Nelson, B. L., and Nicol, D. M., (2004), *Discrete-Event System Simulation* 4th ed. Upper Saddle River, New Jersey: Prentice-Hall Incorporated

Bukchin, J. (1998), A comparative study of performance measures for throughput of a mixed model assembly line in a JIT environment, *International Journal of Production Research*36 (10), pp. 2669-2685

Daaboul, J., Da Cunha, C., Bernard, A., Laroche, F. (2011), Design for mass customization: Product variety vs. process variety, *CIRP Annals - Manufacturing Technology*, 60 (1), pp. 169-174

Darke, P. and Shanks, G. (2002), Case study research, in *Research Methods for Students, Academics and Professionals: Information Management and Systems*, Second edition,

Duguay, C.R., Landry, S., Pasin, F., (1997), From mass production to flexible/agile production, *International Journal of Operations and Production Management*17 (12) , pp. 1183-1195

Ellegård, K. (1996), Restructuring the automobile industry in Sweden: The emergence of a reflective production system, *European Planning Studies* 4 (4), pp. 457-469

Ghosh, S. Gagnon, R J. (1989), Comprehensive literature review and analysis of the design, balancing and scheduling of assembly systems, *International Journal of Production Research* 27 (4), pp. 637-670

Hackman, j.R., Oldham, G.R. (1976), Motivation through the design of work: test of a theory, *Organizational behavior and human performance* 16, pp. 250-279

Hayes R.H. , Wheelwright S.G, (1979), The dynamics of process-product life cycles, *Harvard business review* , pp. 127-136

Hellman F., (Volvo Trucks Group Operation) interviewed by authors 18th April 2013

Hu, S.J., Zhu, X., Wang, H., Koren, Y., (2008), Product variety and manufacturing complexity in assembly systems and supply chains, *CIRP Annals - Manufacturing Technology*57 (1) , pp. 45-48

Hu, S.J., Ko, J., Weyand, L., Elmaraghy, H.A., Lien, T.K., Koren, Y., Bley, H., Chryssolouris, G., Nasr, N., Shpitalni, M. (2011), Assembly system design and operations for product variety, *CIRP Annals - Manufacturing Technology*60 (2) , pp. 715-733

Johansson, B. (2011). Lecture: Methodology for Discrete Event Simulation Projects, Simulation of production systems course, Chalmers University of Technology

Johansson, B. Skoogh, A. (2008), A methodology for input data management in discrete event simulation projects, *Proceedings - Winter Simulation Conference*, art. No. 4736259, pp. 1727-1735

Johansson, R. (2003). Case study methodology. Royal Institute of Technology.

Joppe, M. (2000). The Research Process. Retrieved February 25, 1998, from <http://www.ryerson.ca/~mjoppe/rp.htm>. Cited in Golafshani, N (2003). Understanding Reliability and Validity in Qualitative Research, *The Qualitative Report* 8 (4), pp. 597-607.

Lottridge, A. (2004), Work at the Uddevalla Volvo plant from the perspective of the demand-control model. *Bulletin of Science, Technology and Society* 24 (5), pp. 435-440

Musselman, K.J. (1994), Guidelines for simulation project success, Winter Simulation conference, 11-14 December 1994, Buena Vista, FL, USA

Pandremenos, J., Paralikas, J., Salonitis, K., Chryssolouris, G., (2009), Modularity concepts for the automotive industry: A critical review, *CIRP Journal of Manufacturing Science and Technology* 1 (3), pp. 148-152

Purnomo, H.D., Wee, H.-M., Rau, H., (2013), Two-sided assembly lines balancing with assignment restrictions, *Mathematical and Computer Modelling*, 57 (1-2), pp. 189-199

Rachamadugu, R., Talbot, B., (1991), Improving the equality of workload assignments in assembly lines, *International Journal of Production Research* 29 (3) , pp. 619-633

Razaznejad, B., (2011). Volvo Production System, product development process, Volvo Internal website (28th May 2013)

Robinson, S., and Bhatia, V. 1995. Secrets of successful Simulation projects. In *Proceedings of the 1995 Winter Simulation Conference*, ed. C. Alexopoulos, K. Kang, W. R. Lilegdon, and D. Goldsman, 61–67. Arlington, Virginia. Cited in Johansson, B Skoogh, A, A methodology for input data management in discrete event simulation projects. *Proceedings - Winter Simulation Conference* , art. no. 4736259 , pp. 1727-1735

Salvador, F., Forza, C., Rungtusanatham, M., (2002), Modularity, product variety, production volume, and component sourcing: Theorizing beyond generic prescriptions, *Journal of Operations Management* 20 (5), pp. 549-575

Scholl, A. (1999), *Balancing and Sequencing of Assembly Lines*. Second edition, New York: Physica-Verlag

Uğurdağ, H.F., Rachamadugu, R., Papachristou, C.A., (1997), Designing paced assembly lines with fixed number of stations, *European Journal of Operational Research* 102 (3), pp. 488-501

Vaccaro, P.A., (2012), *Assembly line balancing*, isites.harvard.edu
(<http://isites.harvard.edu/fs/docs/icb.topic1115859.files/CHAPTER%209%20-%20Layout%20Strategy.ppt>) (29th May 2013)

Volvo Production System - På väg mot världsklass (2013), Volvo Internal Documents

Voss, C., Tsikriktsis, N., Frohlich, M. (2002), Case research in operations management, *International Journal of Operations and Production Management* 22 (2), pp. 195-219

Wang, H., Zhu, X., Wang, H., Hu, S.J., Lin, Z., Chen, G., (2011), Multi-objective optimization of product variety and manufacturing complexity in mixed-model assembly systems, *Journal of Manufacturing Systems*, 30 (1), pp. 16-27

Wazed, M.A., Ahmed, S., Nukman, Y., Ale Ebrahim, N., (2012), Models for component commonality in multistage production, *Applied Mechanics and Materials* 110-116, pp. 258-266

Williamson, K., (2002) *Research Methods for Students, Academics and Professionals: Information Management and Systems*. Second edition, Wagga Wagga, New south wales Australia, Centre for Information Studies

Özgün, O., Barlas, Y., (2009), Discrete vs. Continuous simulation: when does it matter? , the 27th International conference of the system dynamics society, 26-30 July 2009, Albuquerque, NM, USA