



# **ARCHITECTURE AND MULTIMODAL STIMULATION IN NEURO INTENSIVE CARE**

Master Thesis at Chalmers Architecture  
Dennis Carlsson Spring 2012

# Aknowledgement

*Examinor* Peter Fröst

*Tutor* Stefan Lundin

*Insight and support*

Kristina Sahlqvist, Johan Snygg and Björn Vickhoff  
Cecilia Skoog, Catherine Eriksson Ritzen and the  
staff of NIVA at Sahlgrenska University Hospital  
Family and friends



**CHALMERS**



# Table of Content

Aknowledgement	2	Experiencing the ICU environment	23
Table of content	3	Evidence Based design	24
Abstract	4	Analysis	25
Thesis structure	5	Machines	26
Interdisciplinary study	6	Outside	27
		Light and sound	28
The brain	7	Enriching the enviroment	29
The neuron	8	Estetics	30
Cortical and Subcortical structures	9		
Senses	10	Three possible conversion	31
Plasticity and Neurogenesis	11	Developed plan	32
Neuroarchitecture	12	Department feedback	33
Applications	13	Revised proposal	34
Enriched enviroment	14	Ceiling	35
		Furnishing	36
The disseas	15	Sections	37
Neuro Intensive Care Unit	16	Media system	38
The department	17	Model Photos	39
Treatment rooms	18		
Coping with stresss	19	Conclusion	40
Patient perspective	20		
Staff perspective	21	<i>Sources</i>	
Relatives perspective	22	Text, Media & Images	41

## ABSTRACT

From the 1960s to present day there has been several studies conducted on rats subjected to enriched environments that shows the increased brain mass and plasticity within the cortical areas.

Stimulating the plasticity can be used to improve the recovery in patients suffering from brain damage.

With this research as inspiration participants from the Sahlgrenska university hospital, GU, HDK and Chalmers has started a study called “The effect of directed multimodal stimulation in intensive care”. The question in this study is to investigate whether an enriched environment can improve the experience, recovery and rehabilitation in the patients that has received surgery for subarachnoid haemorrhage (stroke).

*The primary objective of this master thesis will be to provide a suggestion of how architecture can be used as a mean for enrichment and support other mediums that can be used in this purpose.*

By using knowledge from Evidence based design and observations from neuroscience in relation to patient’s condition, department requirements, we can create a platform for investigating what an enriched environment can be for the patients. The recent advancements made within the field of neuroscience have attracted an interest from architects resulting in the interdisciplinary field of neuroarchitecture.

*A secondary objective in this thesis is to investigate the potential and purpose of neuroarchitecture.*

The results obtained from the study of the enriched patient room at Sahlgrenska can tell us if the enrichment has a positive effect on the recovery, experience and rehabilitation.

The benefits of this study could be used as a strong argumentation when it comes to investing in a more stimulating design of new hospital environments.

The larger implication that the knowledge of enriched environment brings forth is that we as planners and future participants in the building industry are responsible not only for the health and happiness of our clients but also the environment that influences the development of their brains.



# Thesis Structure

## *Introduction*

A short introduction to the thesis with abstract, structure and a explanation about the interdisciplinary study.

## *The Brain*

General layman neuro physiology as foundation for continued discussions about plasticity, enriched enviroment and neuroarchitecture

## *The Context*

Explanation about the disease, the site(neuro ICU) and the clients(patients, staff and relatives).

## *The Proposal*

Analysis of the Sugestion of how the room could be designed to contain and support enrichment

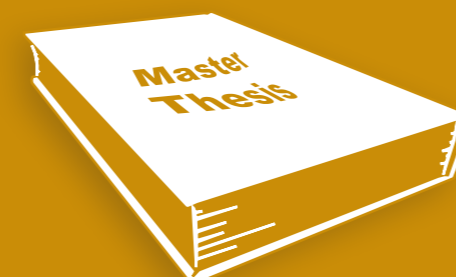
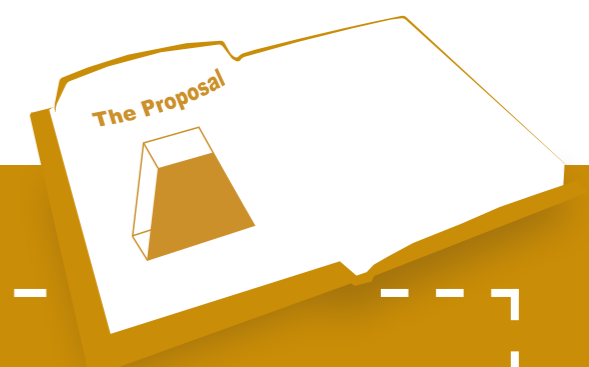
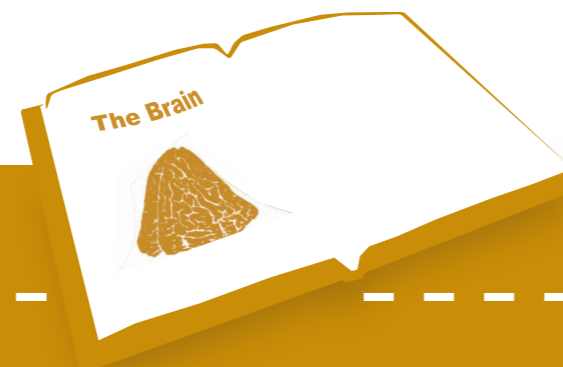

# Interdisciplinary study

“**Purpose:** The project intends to study the effect of multimodal stimulation (the cumulative effect of music, architecture, design, tactile contact and social stimulation) for recovery in patients who had surgery for subarachnoid hemorrhage (SAH).”

“**Intervention:** To achieve the purpose, four studies (three for music and one for music, design, architecture, tactile contact and relatives involvement).”

## PARTICIPATING ORGANISATIONS

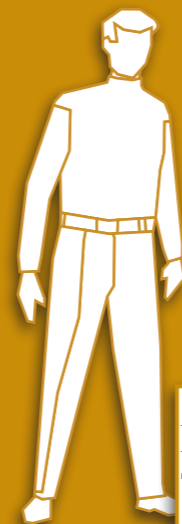
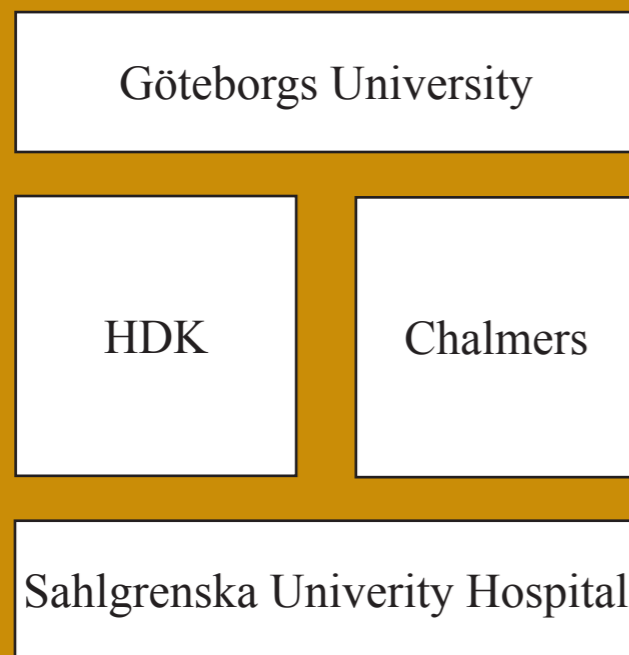

Input

## STUDY PLAN

*The effect of directed multimodal stimulation in intensive care*

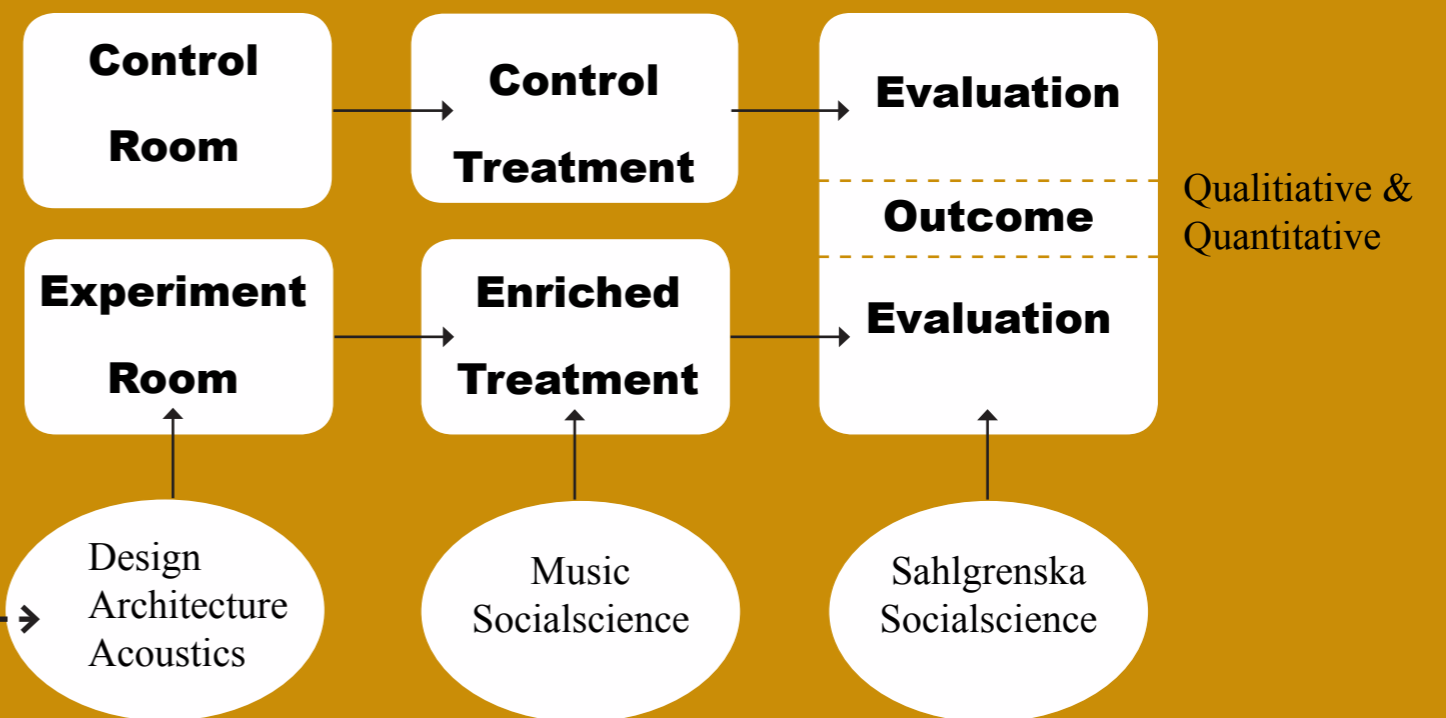

The Neuro intensive care unit at Sahlgrenska provides the study with one test room that will provide the sensory enriched environment and one control room that will remain unchanged for comparison.

50 conscious patients operated for subarachnoid haemorrhage will be placed in each room and stratified in age.

Subjects with symptoms of confusion, mental disorders and cognitive impairment will be eliminated from the study.

Patients recently operated for subarachnoid haemorrhage (SAH) are in the hazard of being affected by stress related postoperative complications. Postoperative complications like vasospasm, post-traumatic stress disorder and postoperative delirium can increase the risk of mortality and prolong the time needed for recovery.

Stress also has the negative effect that it works against the

brains plasticity that are part of the healing process.

In the design of the test room for the enriched environment it becomes important to add properties that can be defined as enriched but even more important to remove or change aspects that can cause stress and confusion.

The design should not only target the patients but also the relatives and staff working there.

Special attention should be laid on the light, colours, shapes, materiality and acoustic quality's.

In the development of the test room an interior architect, designer, acoustician and a musician will be working together under management from the chief of surgery, anaesthesia and intensive care.

Examination and evaluation will be performed in both a quan-

tative (statistics and measurable results) and qualitative (interview) way by professionals in areas of care science, cognition science, speech pathology and neuro physiology.

The quantitative and qualitative studies should provide results in;

- time of awakening
- stress
- cognition and psychology
- amount of medication
- Life quality



**“The brain is as big as coconut, the shape of walnut, the color of uncooked liver and the consistency of chilled butter“ Rita Carter(1998)**

The brain is an evolution of not perfection but adaption. Until the 60`s there was a general opinion that our brains were only products of a genetic blueprint but this has turned out to be only part of the truth. It has since then shown that our brains are highly adaptive organs that will be transforming by usage and influenced by the environment we live in. Each brain is for that reason a completely unique piece of machinery, the amount of different ways the neural circuitry can be connected is near infinite. It controls everything that we are and experience from our first to our last breath.



# The Neuron

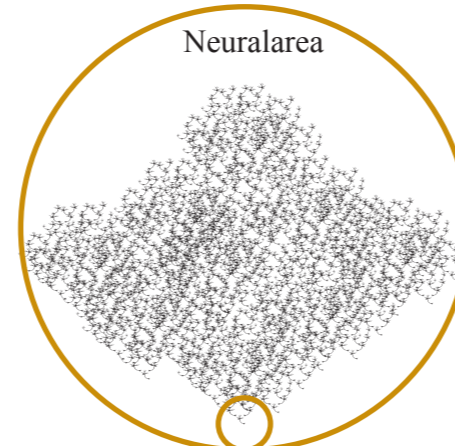
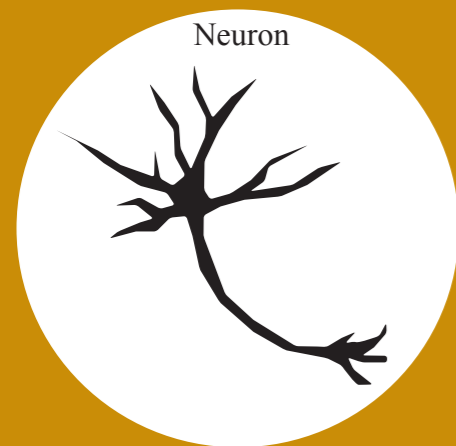
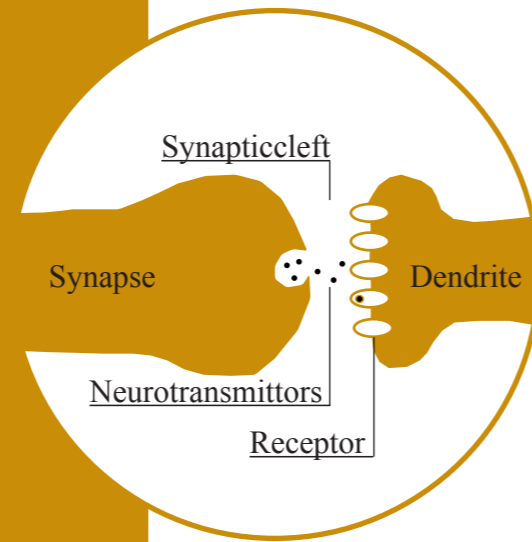
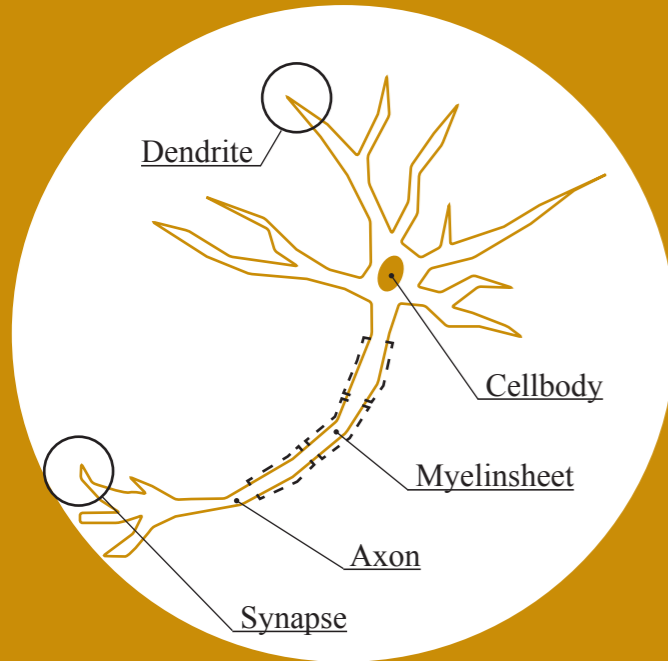

The brain is part of the central nervous system and it consists of about 100 billion nerve cells (of approximately 100 different types) of which 10% are neurons and the rest are primarily glial cells that mainly stabilize the consistency of the fluid surrounding the neurons. Even though the glial cells are 10 times as many as the neurons they only make up half of the cell mass. The neurons (excitatory or inhibitory) are the building block of the brain in average 0,01-0,05mm in diameter and they were first studied by C. Golgi since he discovered that staining brain tissue by a solution of silver chromate made them visible for observation in a microscope. The neurons consist of four major parts:

**Cell body (Soma)** is used for storage of genetic material and also maintenance and production of proteins and molecules that control the functions of the cell.

**Dendrites** are receptors of signals from other cells. The dendrites branch out from the cell body to wire together with intercepting axons.

**Axons** are roots that transmit signals between cells. These can be between less than a millimetre to a meter in length depending on location and task they are assigned. In places where the axons are longer they are coated with a myelin sleeve that hastens the signal. The dendrites are constantly changing. (see plasticity)

**Synapses** are the end part of axons that produce the signal transferred across the synaptic cleft to the dendrite of other cells.

The signal is transferred by an action potential (electric) that moves through the axon (0,001sec) to the synapse releasing neurotransmitters to adjoining dendrites. (there are 50 different types of neurotransmitters)

When the neurotransmitters flow to receptors there is a chemical exchange that locks the axon and dendrite for more effective continued transmissions. This is called a long-term potential (LTP).

The neurons are connected together in larger groups called nerve circuits with different configurations depending on the task they are assigned to do. The configuration and connections are in a constant process of change and adaptation to new conditions. The amount of connections in the brain is incredible, approximately a quadrillion (10<sup>15</sup>).

The brain is so interconnected that it is capable of transmitting a signal from one neuron to any neuron in the brain in seven steps or less.

Networks of nerve circuits are bundled into areas called cortexes that handle specific tasks for the brain and body.

## Cortical areas

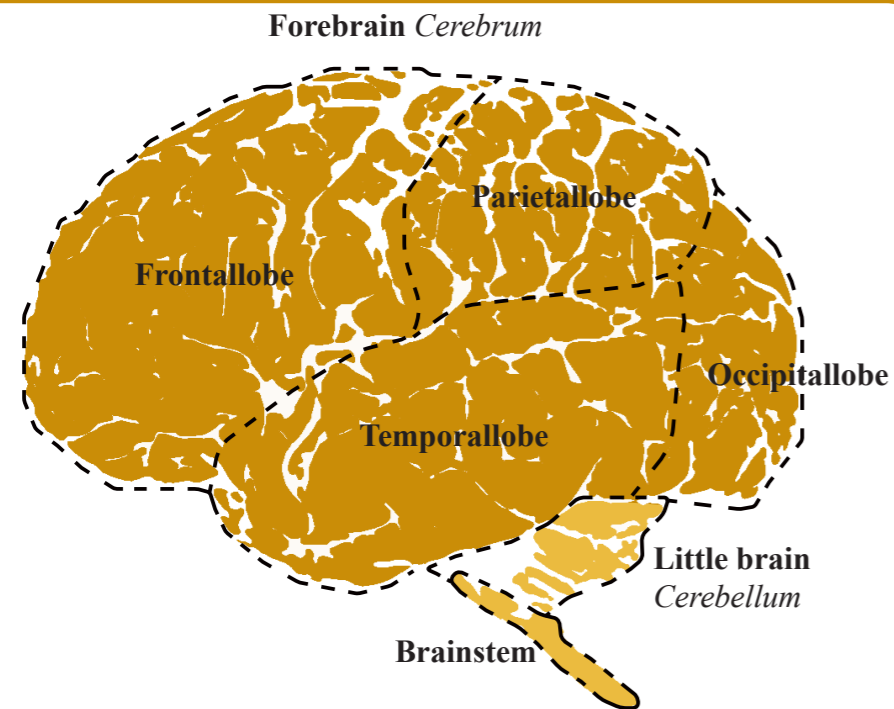

### Brainstem

It consists of bundles of nerves that are connected to the rest of the body. It controls homeostatic processes like vital life functions.

### Little brain cerebellum

It is responsible for learning motoric skills and cognitive memory functions.

### Fore brain cerebral cortex

The fore brain can be described as 6 layers of wrinkled cloth of neurons.

It is divided into the left and right hemisphere consisting of four lobes on each side. The two hemispheres are not symmetrical in its functions. In general the left side is more focused on language and analytical skills

while the right one is often more specialised in emotions and spatial skills.

### Frontal lobe

Thinking, speaking, memory, muscle control

### Temporal lobe

Hearing and language

### Parietal lobe

Spatial perception

### Occipital lobe

Vision

## Subcortical structures

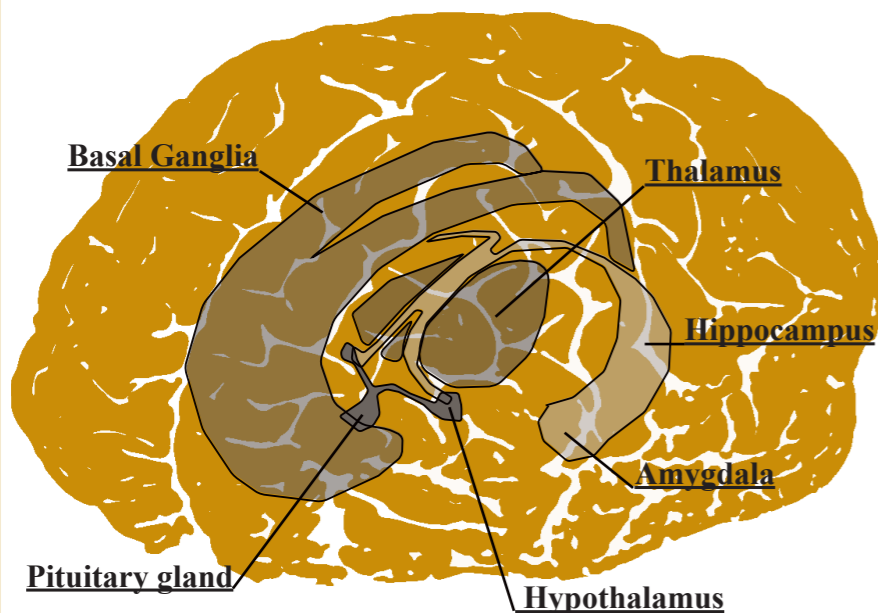

### Basal Ganglia

Works together with frontal cortex and has several executive functions. It does voluntary motor control and procedural learning.

### Thalamus

Is relocating functions to cortical areas, controlling where we store skills and senses. It collaborates with the cerebellum, hippocampus and cortex's to form meaning to what we perceive.

### Hypothalamus

It controls many autonomic functions like reflexes but also regulates sleep, heat, sexuality and thirst.

### Pituitary gland

Is part of the hypothalamus and releases hormones in response from it.

### Hippocampus

Has the control function for creating memories and recalling them. When we are finding our ways in complex environments it is used to remember image sequences that will help us.

### Amygdala

It creates emotional responses from sensory input received from the thalamus. Fear, joy, love and sadness have its origin here.

# Senses

There are five primary senses according to the Aristotle's definition, sight, hearing, touch, taste and smell. The primary senses except smell are transmitting their signals thru the thalamus while smell is directly linked to its cortex. (This causes the sense of smell to be inactive when we are asleep)  
The smell and taste senses are linked so that they influence each other's experiences.  
All types of sensory signals are stored in the same type of neural energy.  
Depending on the cortical location where it is placed it translates into the right type of perception.  
There are different definition between neurologist about how many senses we have and what defines a sense.

Other functions that are most often considered senses are balance, motion, direction, temperature and time.  
The simplest things perceived which we take for granted is in the brain an extremely advanced chain of processes involving many different cortical areas and subcortical structures.  
When we receive the sensory inputs to our brains the memories, emotions and thinking creates an instant definition of the object.  
A function called priming makes this possible. It works by when we percept something repeatedly our brains develop a more efficient neural chain that uses fewer neurons to deliver the information to the associated cortical area.

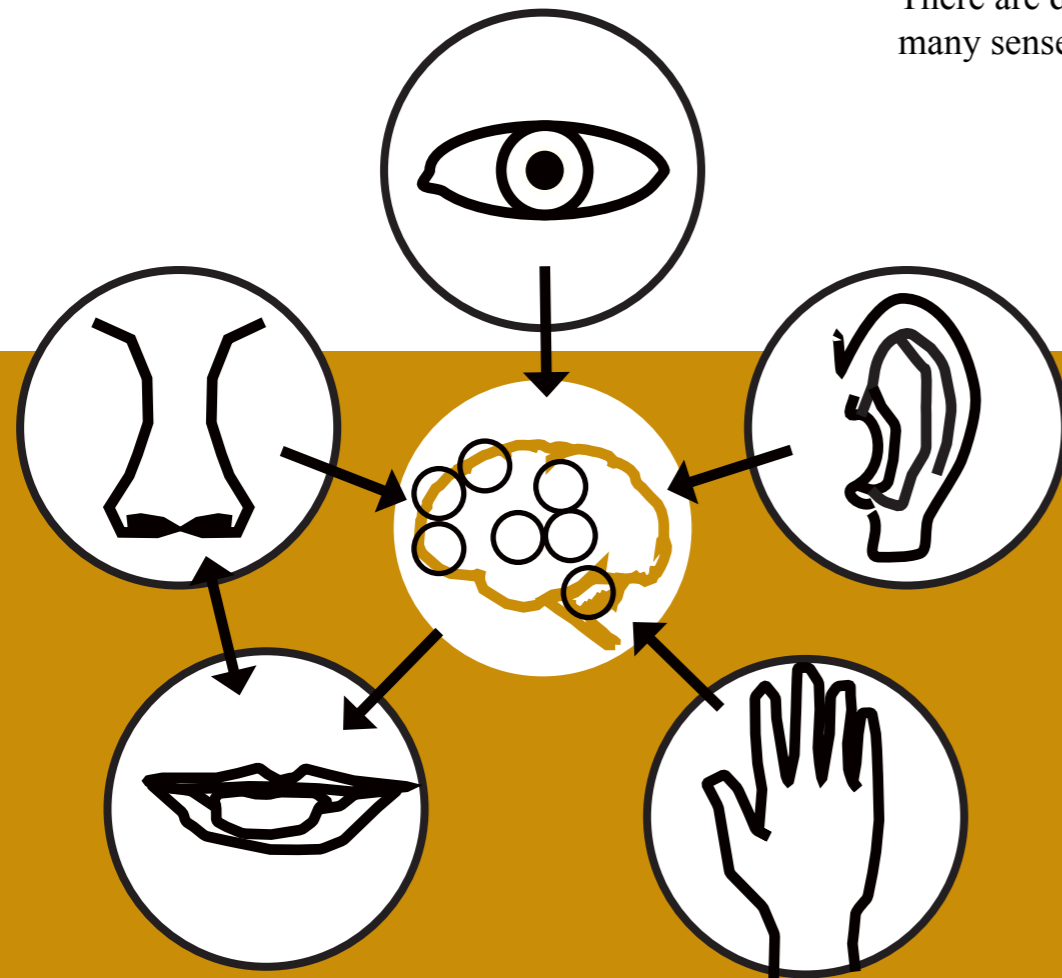



# Neuroplasticity and neurogenesis

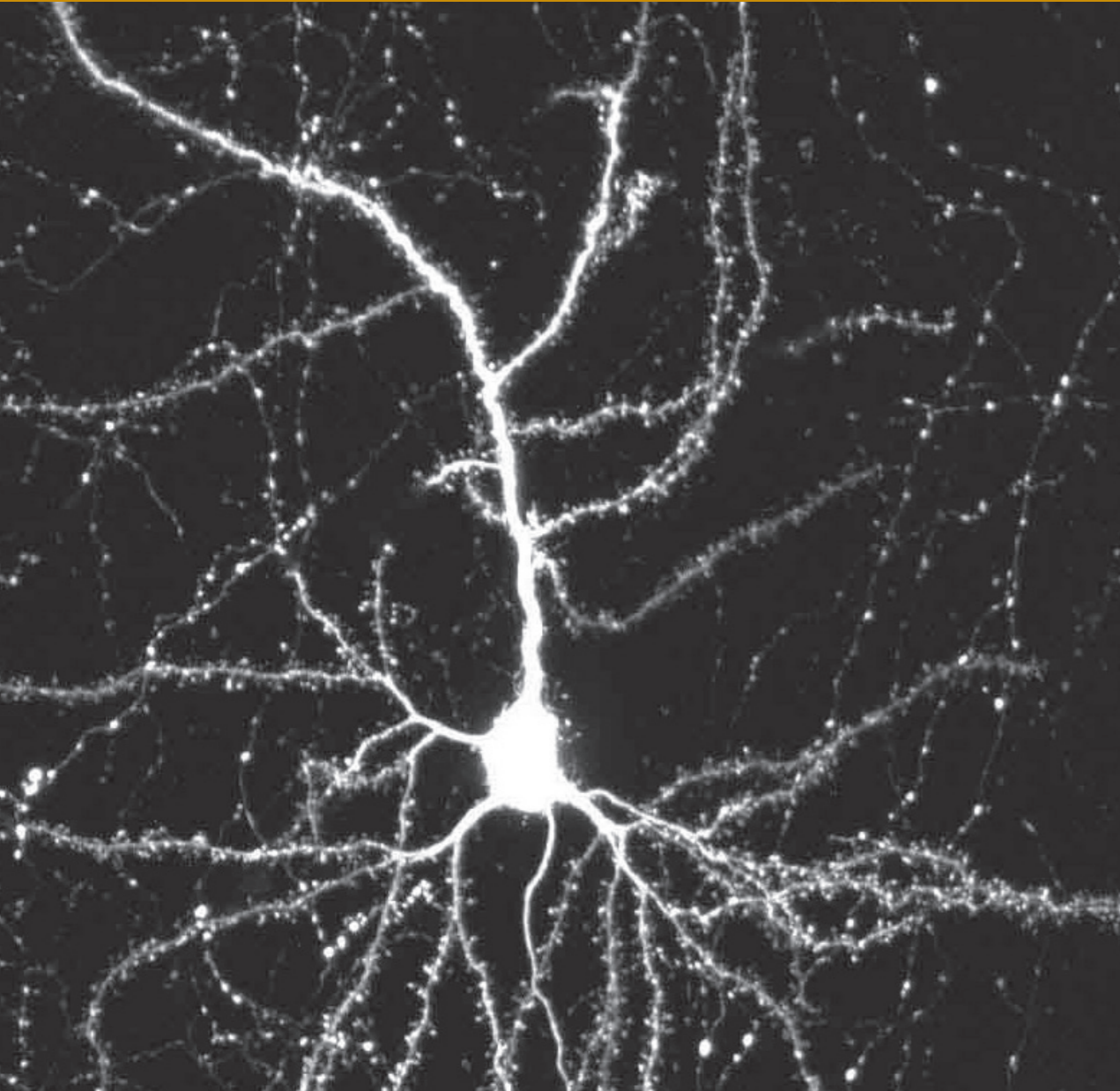

When we arrive to this world our brain has already produced all the neurons it needs for our lives but the newborn brain only weights a quarter of the mature brain. The reason for this is that the newly born brain has only produced a small amount of the neural circuitry (dendrite and axon braches) that an adult needs to function.

There are constant transformations and reconfiguration in the circuitry when it is trying to optimize the efficacy of the brain. Dendrites die and regrow on sometimes daily basis. This plastic like process of change and development is called plasticity.

The plasticity is at its strongest during certain phases in the childhood but will be active our whole life's. Some skills can be obtain in a higher level if developed during the right phases earlier in life then later on.

By performing actions and using our senses we ensure that the circuitry parts are maintained operational and not considered unnecessary by the brain. Use it or lose it.

If we lose a function in the brain like the loss of a limb or a sense these parts will be un stimulated and start to degrade which opens up possibilities for other areas to expand in their place. This over lapping expansion is most effective if the accident happens early in life or from birth when the plasticity is at its best.

For instance a person born without sight will develop a more advanced cortex's for hearing and tactile sensory in some of the areas that by other people would be used for sight.

The brain is extremely fragile and damages in very small and specific parts can easily be fatal but still the brain manage rearrange itself and finding ways of functioning even if it has sustained severe damage.

We know that after birth brain cells cannot divide by them self and replace dead ones but in the hippocampus and the sub ventricular zone of the brain there are neural stem cells that moves around and they are both self-renewing and multi potent.

These stem cells can transform them self into different types of neurons a process that is called neurogenesis. (Birth of neurons)

This function is most active before birth and decrease by age but continues thru the whole life cycle.

This phenomenon was first detected 1990 by the neuroscientist Fred Gage. There are several factors that influence the production of the neural stem cells, for instance stress and lack of sleep works as inhibitors while exercise and training.

There are some scientists that are critical to what extent neurogenesis can be used to repair damaged areas, for instance when a neuron dies it is changed to a scar cell that cannot be replaced directly.

## Training induced plasticity

“Mental training activates most of the same circuitry in the brain as real actions does, and mental practices another method preliminary reported to be of value.”<sup>1</sup>

When rehabilitating amputees and activating the cortex that is corresponding with the lost limb, training with their remaining limb in front of a mirror has proven to activate neurons in the lost region. The region is both activated by performing a task but also by seeing a task that it thinks it performs.

Task oriented training has proven to be more effective when rehabilitating the lost motoric functions then the training by its own accord.



H.F. Mallgrave, The architect's brain: Neuroscience, Creativity and architecture, 2011

J.P. Eberhard, Brain landscapes, 2009

B.B. Johansson, Brain plasticity in health and disease, 2004<sup>1</sup>

# Neuroarchitecture

“As neuroscientists, we believe that the brain is the organ that controls behavior, that genes control the blueprint, the design, and structure of the brain, but environment can change modulate the function of genes, and ultimately the structure of our brain. Changes in the environment change the brain and therefor they change our behaviour. Architectural design changes our brain and our behaviour.” Fred Gage(1990)

Architecture has always differentiated itself from other types of art and sciences since it holds the interdisciplinary quality, possibility and limitation. When we as architects design a building we are required to consider and balance many different factors like programmatic planning, aesthetic qualities, economics, structural, sustainability etc. Many of these factors are in some way depending and relating to us as humans beings and in the end thereby subjected to or affecting the functions of our brains.

From an architect’s point of view there are many rewarding insights obtainable by studying the neuroscience.

The fundamental of how we can create buildings, institutions and city’s that make sense and produces health and happiness for the users can to a large extent be found within the neuroscience.

In the 1990s the architect John Paul Eberhard started a dialogue with the neuroscientist Fred Gage from the Salk institute about creating a bridge between the two subjects. The fruit of the exchange resulted in several books published and later on in 2003 the Academy of neuroscience for architecture was founded.





# Fields of application

There are several areas of architecture that has been investigated more thoroughly than others with a neuro-architectural point of view and where the neuroscience can significantly improve the performance.

### *The general environment*

How do we percept and experience architecture, what is by our brains considered aesthetically appealing.

### *The healing environments (hospitals)*

How do our brains work in the healing process and how can we create environments that support recovery from injuries and diseases.

### *The learning environments (schools and library's)*

How do we learn things and what kind of environments improves the learning process.

### *Age related environments (Kindergartens and elder housing)*

How does the brain work in the early stages of life? Which parts of the brain is matured and when. In what ways does ageing affect the brain and how can we build an environment that improves our self sufficiency, safety and life quality.

### *The working environment*

We can increase employee productivity and wellbeing as well as creating an more creative environment by understanding how the brain works.

### *The city*

By understanding how the brain reads and relates to our surroundings we can plan city's that are more pleasant, safer and easier to navigate in.





# Enriched environment

1874 Charles Darwin discovers that there were differences in the brain volume in domesticated rabbits compared to those that lived in the wild.

He comes to the conclusion that wild rabbits have developed larger brains because the need of using the intellect and senses in order to survive.

There have been a several studies done on animals (most often rats) dating from 60s until present day about the effects of an enriched or impoverished environment on the brain.

Today the concept of an enriched environment and its beneficial effects on the brain has been accepted as facts in the neuroscientific community.

Several studies on enriched environment were conducted by Marian C. Diamond between the years 1964 and 1988.

In one of her experiments she used 36 Long-Evans rats that were divided into impoverished, standard and enriched environments. All the animals in the experiment had the same access to food, water and light.

In the enriched (70x70x46cm) cage 12 of the rats lived with the possibility to use wheel, ladders and mazes to explore their environment. These so called toys were changed regularly to provide new challenges.

The standard cage (20x20x32cm) housed 3 rats at a time and was not fitted with any type toys.

And in the impoverished cage the rats were isolated by them self in very small cages without access to toys.

The enriched part in this experiment can be described as a combination between toys and friends.

When the rats had been subjected to their environments for 30 days they were anesthetised before getting the brains removed and examined.

The result from the study showed that the rats in the enriched environment had developed an increased thickness of cortex in comparison to rats from the standard environment. The rats that had been subjected to impoverished environment had reversed development, a decrease of thickness in comparison to the standard environment.

“With more detailed studies, the cortical thickness increases were found to be due to several factors, including increased nerve cell size, number and length of dendrites, dendritic spines, and length of post-synaptic thickening as measured on electron microscopic pictures of synapses.”(Diamond et al. 1964 and 1988)

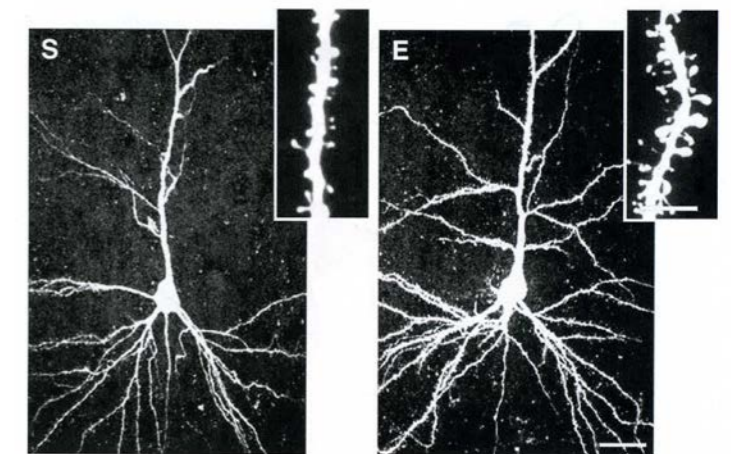
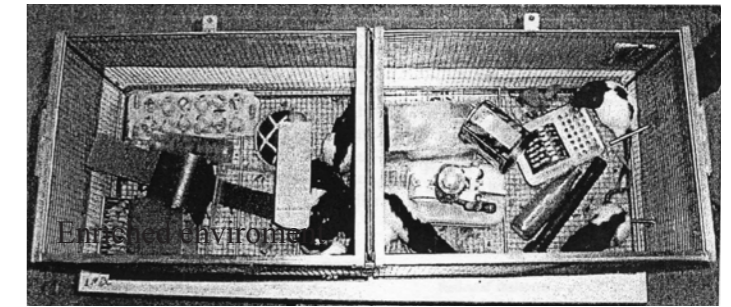

Neuron in (S)normal

(E)enriched environment

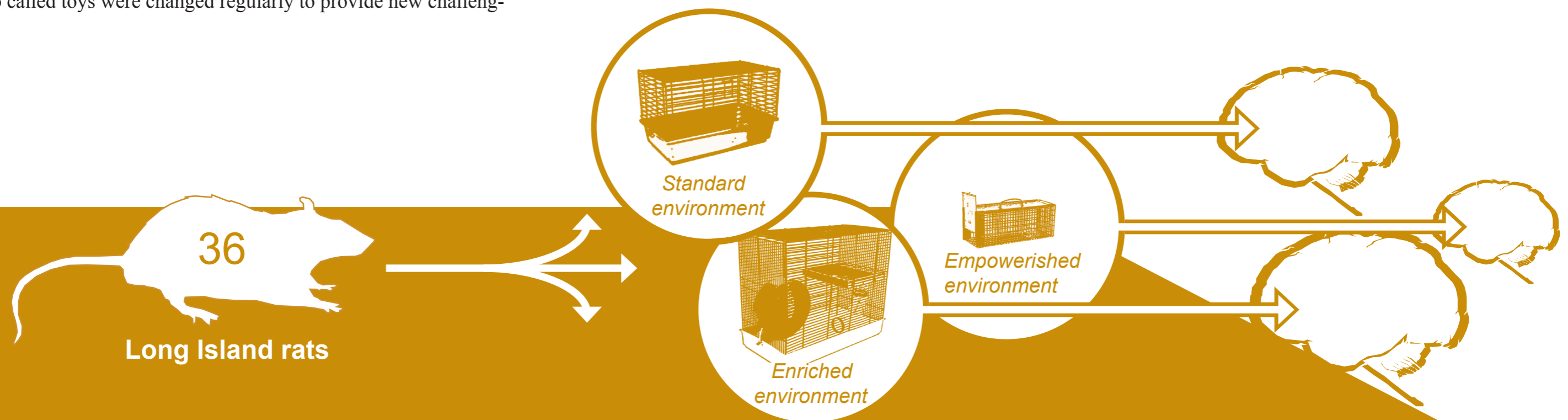

# Subarachnoid Hemorrhage

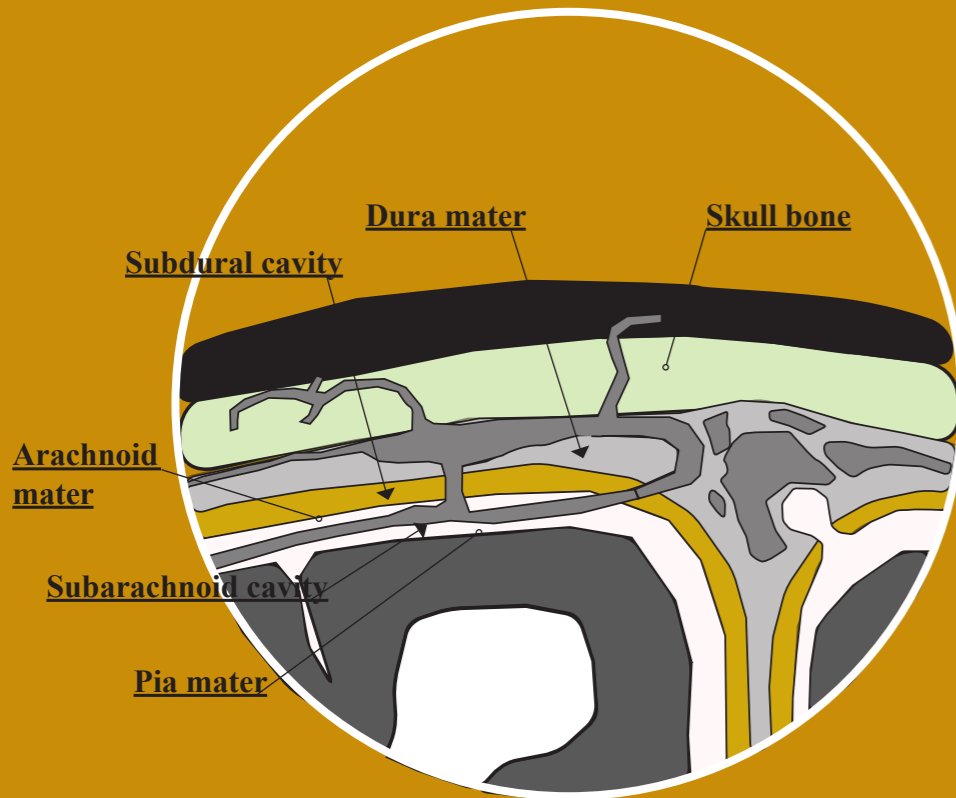

The first recorded stroke is believed to be the father of medicine Hippocrates

There are two types of stroke ischemic and haemorrhagic. The ischemic stroke is caused by a decreased blood support in the brain, while the haemorrhagic is caused by accumulation of blood in the brain.

The subarachnoid haemorrhage (5% of all strokes) is a bleeding in the subarachnoid space between inner (Pia mater) and the middle (Arachnoid mater) cranial meninges that surrounds and protects the brain.

This is usually caused by a rupture of an brain aneurysm or caused by external force to the head.

The statistics of this injury are grave; approximately 30% of all affected die immediately and 30% suffers from rebleeding after the first incident. Only 20% of all the patients will be completely recovered after treatment.

There are several neuro psychiatric syndromes (not diseases) that can interfere and make the recovery difficult;

**Vasospasm** is severe contraction of the blood vessels in the brain that (in about 50% of the cases) can lead to permanent brain damage caused by the lack of oxygen. The amount of cortisol measured in the patients suffering from vasospasm indicates that it is stress induced.

**Postoperative delirium** and **Postoperative cognitive dysfunction (POCD)** are also stress related syndromes that can commonly (50% of subject in a study suffered from postoperative deliriums) be found in intensive care units. Even if mature patients are more likely to be affected by postoperative delirium and POCD it can happen to patients of any age and in operated children as well. These syndromes are connected and caused by a biological brain reaction in the cortex's of hippocampus and amygdala.

**Post-traumatic stress disorder (PTSD)** is commonly found in victims that have been exposed to war but also survivors of any situation perceived as life threatening.

## Treatment

Depending on the damage location and spreading different types of surgery (patching from inside of the ruptured vessel or burning from the outside) and medications will be necessary.

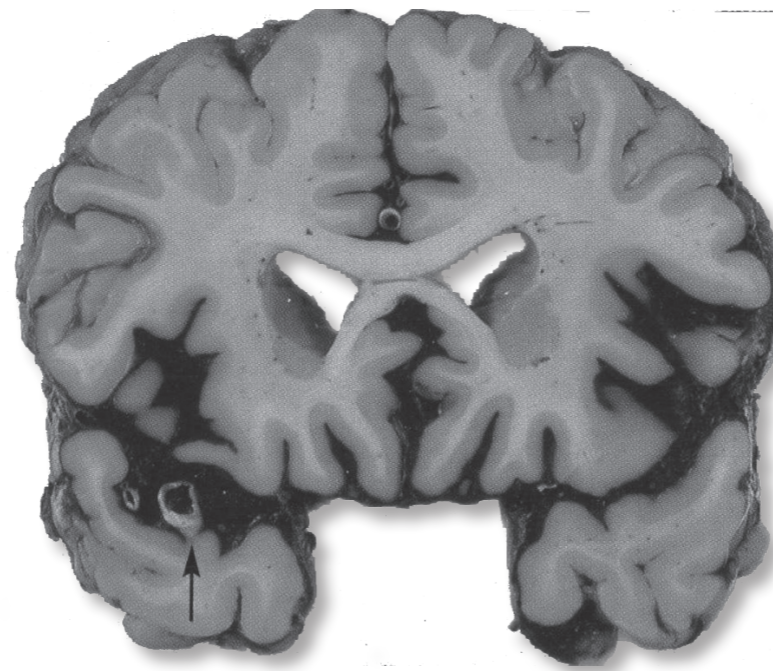

Subarachnoid Hemorrhage

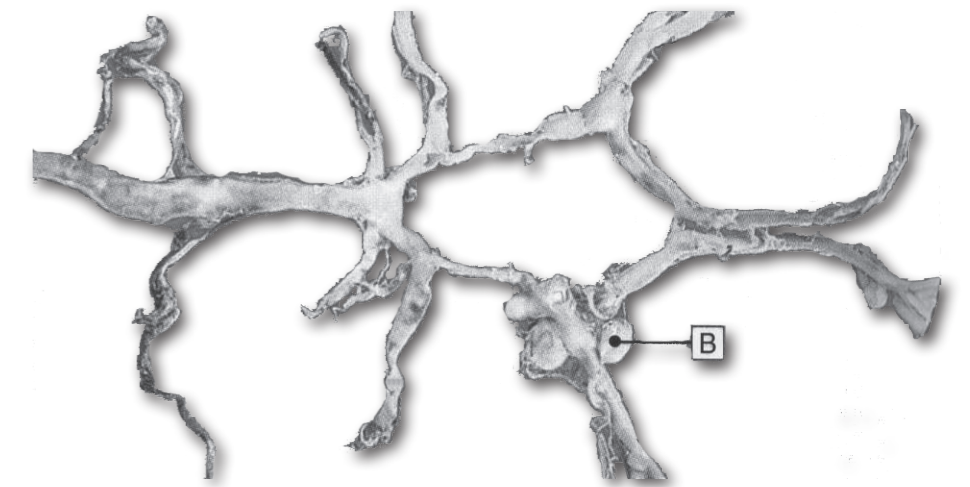

Berry aneurysm



# Neuro ICU Sahlgrenska



The Neuro Intensive Care Unit of Sahlgrenska University Hospital is located in the 3rd floor of the southern part of the main building. It was recently renovated (2004) and has since then been housing the Neuro Intensive Care Unit. During two days I had the opportunity to visit the department and make observations of their daily routines. This part of the thesis that addresses the department, staff and patients are mostly based on the observations and informal discussions with nurses and doctors on site.



# The department

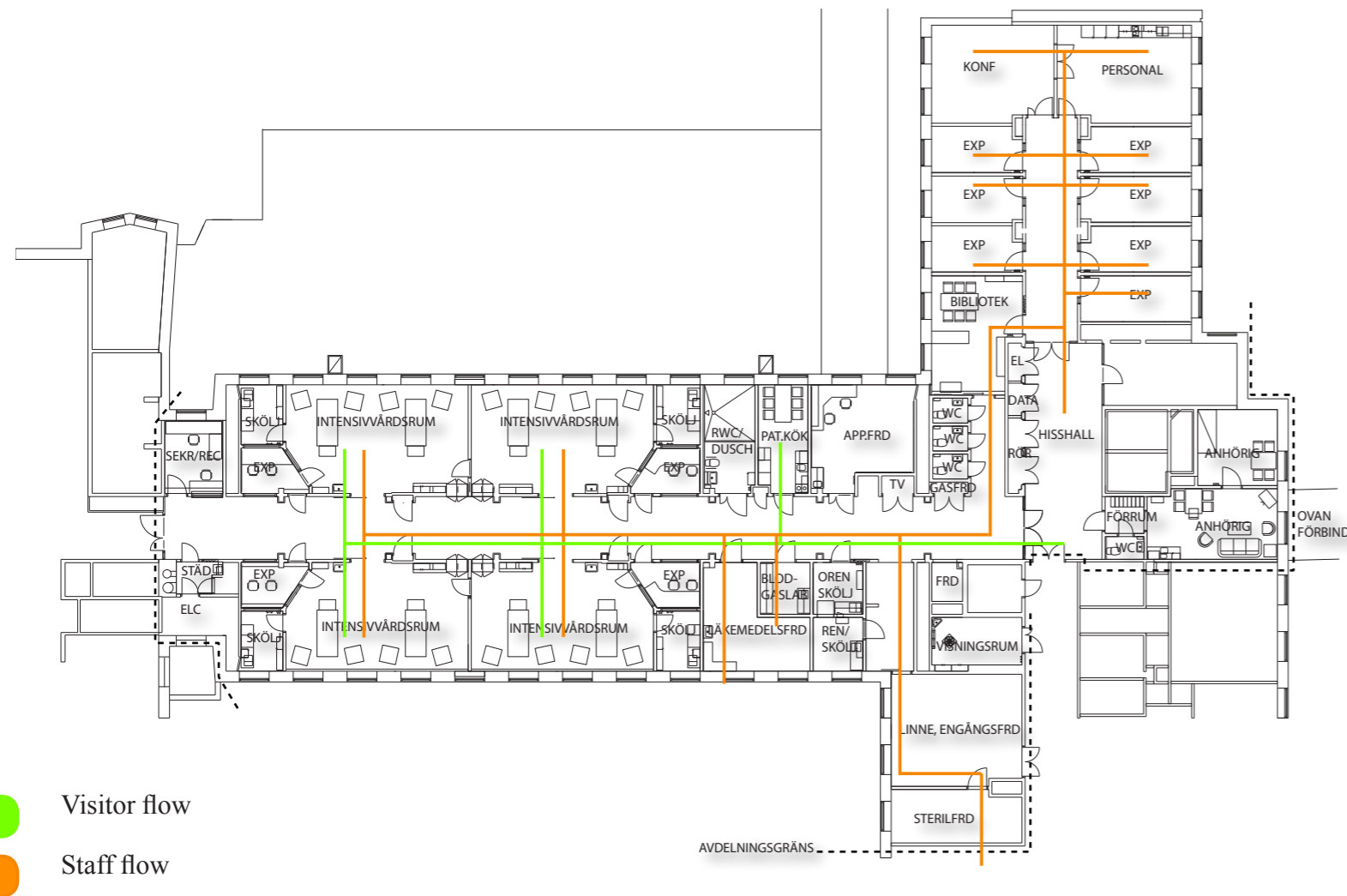

The Neuro ICU is a post-surgery department that are specialised in the treatment of brain and spinal injuries caused by stroke or other trauma. From plan to details the department has been developed in close collaboration with the staff for maximum efficacy and excellent working conditions. Inside of the unit there are 4 treatment rooms with two beds each. These rooms are oriented in north and south direction. The rooms are close to the unit entrance and elevators so that visitors will have easy to orientate, easy access when moving patients. The department has a pleasing appearance to it with blue, grey and earth colours in combination with inlayed bright wooden features like doorframes. In the corridor outside the patient rooms there are wall paintings covering the walls with nature motifs that enhances the welcoming feeling for the family that visits. In the staff area with lunch and meeting room and journal writing stations there are more glassed walls that allows light to reach in to the corridor. This breaks up the corridors institutional feeling makes it seem more open and less confined. The staff that works in the department is very satisfied with the functionality and its features. When asked if there were anything else that they would prefer or would like to have different, there were very small and few things that they thought would actually improve their condition and experience.





# Treatment rooms

The care rooms has as the rest of the unit been designed in high detail with the collaboration and influence of the staff hence it is a very efficient working environment.

As with the department in general there were not many things that the staff would have in a different way. The few things that come up during discussions were that the acoustic quality can be improved and some part of the supply storage is too high for reaching ergonomically. When asked if they would benefit from automated patient lifts they were unsure whether it would make things more time consuming rather than actual benefits.(they have developed good working routines when it comes to moving the patients)

The average patient stays in the room for approximately a week after operation and before being transported to other departments.

When there is a swap of patients the room is completely sterilized to prevent diseases from spreading between patients. Hence it is important that all materials in the room has a quality that survive exposure to disinfection cleaning agents and that there are no unnecessary surfaces that will require cleaning.

The average cost of intensive care room is approximately 35000kr/day<sup>1</sup>.The high cost of the room are a combination of expensive equipment but foremost the required amount of staff that is needed for treatment and constant monitoring. This means that there is high pressure on the beds and patients cannot stay when they are stable enough for treatment at other less cost consuming departments.

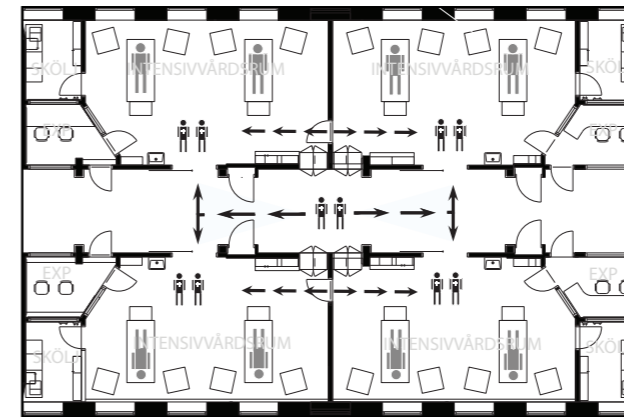
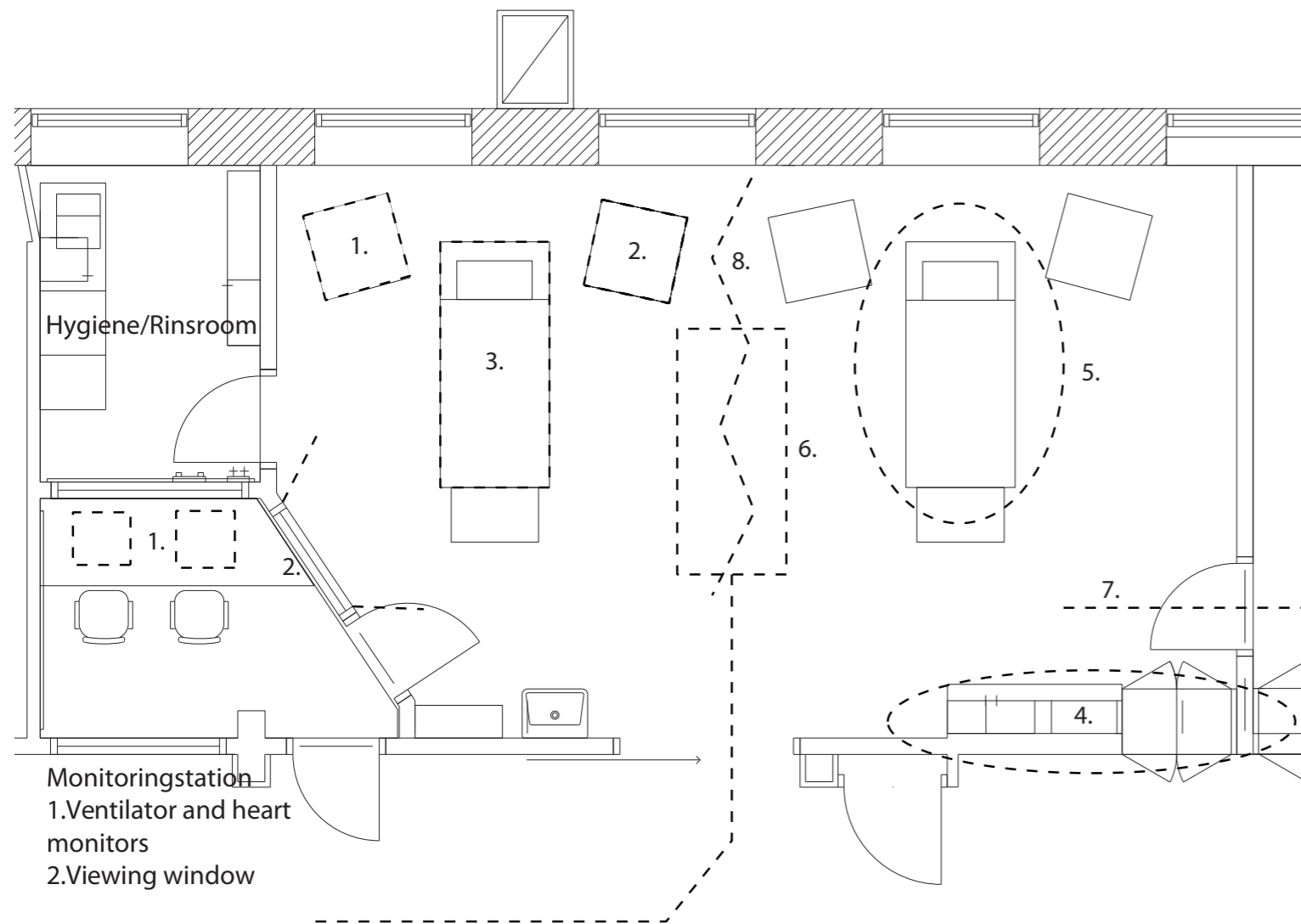

## Nurse staffing

For each treatment room with two patients there are at all times two nurses present. Additional assistance in case of need can be received from the two nurses that work floating in the corridor or in some cases borrowed from the neighboring room.

## Treatmentroom

- 1.Parenteral or nasogastric nutrition/medication
- 2.Mechanical ventilator and heart monitor
- 3.Mechanized bed
- 4.Supply storage and medical preparation desk
- 5.Space around the bed for ergonomic work
- 6.Space for emergency/transferring bed
- 7.Connection between rooms for assistance
- 8.Separation screen

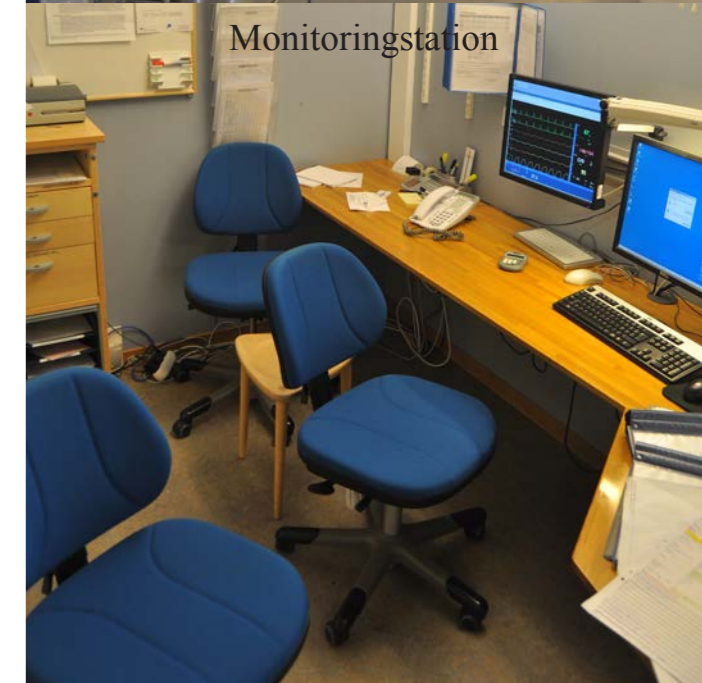

# Coping with stress

## **Sense of coherence**

Medical Sociologist Aaron Antonovsky started study the relationship between stress, health and coping in survivors from concentration camps

He came up with the formulation of sense of coherence that can be used to assess whether a stress factors would be harmful or if the victim has the necessary means to cope with it.

The term “sense of coherence” consists of three parts comprehensibility, manageability and meaningfulness. These parts are essential to our wellbeing and the insufficiency in those would invoke harmful stress.

The sense of coherence does not only apply to the patients but to the family and staff as well.

### **Comprehensibility**

Is the thought that you can predict and understand events in your life.

### **Manageability**

It means that the events that occur in your life are possible to handle with your ability and resources.

### **Meaningfulness**

It is the motivation that the outcomes of events are worth influencing and they carry significance.

# Patient perspective

## The sequence of actions/occurrences

There are several complications that can happen (rebleeding) which will cause the patient to go thru these actions again.

### The incident

Either an accident or a genetic and habit induced rupture has happened that will cause symptoms that corresponds to a spinal or brain injury. (The symptoms can be motoric, cognitive and speech difficulties as well as pain and nausea.)

### Transportation

If the patient is lucky he is with friends or people that perceive the symptoms and calls an ambulance or drives them to the emergency. (Time is of most importance)

### Operation

Depending on the damage location and spread the patient will undergo operation that will if successful stop the damage from spreading and stabilise the patient.

### Postoperative recovery (At the Neuro ICU)

During the first time directly after the operation the patient are under the influence of heavy medication and life-support (nutrition and breathing).

He will need to be constantly surveyed since the high risk of complication and that the life support machinery could fail.

### Recovery

When the life support is no longer necessary and the patients are considered stable the patient is moved to another recovery department in the city that they come from. (Either surgery department 18 or NIMA 23 if they live in Göteborg.)

### Home rehabilitation

When the patients are stable enough and hospitalisation unnecessary he will continue his rehabilitation from home with help from family. He will return to hospital for regular check-ups and physiotherapy.

## The condition of the patient

The patients are at arrival from operation unconscious and become gradually more awake when the anaesthesia wears off. When the patients are awake they are at usually first in a state of delirium being unrest full and disorientated but become clearer when they progress in their recovery. The average stay of a patient is about a week but it can vary depending on complications and individual factors.

Since there are lot of disturbances from the life-support machines, staff communicating the patient are also often subjected to deprivation of sleep or reduced sleep quality. This has a counteractive effect on the recovery and increases the levels of stress in the patient.

The patients can have family visiting in specific hours before the silent resting period at 15<sup>00</sup>.

These visits are important to remind the patients who they are and to reassure the patient with a familiar face so they know that they are not forgotten.

While being treated in this first state of recovery the patient are quite fragile and susceptible for stress, confusion and overstimulation.

The sense of coherence are vital for the patients recovery since the lack of comprehensibility in treatment and environment would further disorientate the patient that might already be in a confused state of medication and delirium. It is also important that the manageability is balanced so that the patient's expectations, therapy and recovery are within the patient's ability.

The last and most important part is the meaningfulness which can be enhanced by the family's presence. The patient needs to believe and be motivated that they will recover and they will have life to come back to after the injury.



## Staff perspective

### The state of the employees

There are many different type of employees that are working within the department some of them more frequently than others. The cleaning and maintenance staffs are working here as well but they do not share the employee/patient relationship that the nurses, doctors and therapists do.

Even thou the cleaning and maintenance staffs share some of the stress and strain of cutbacks in the department with the caregivers their work differentiate in the strains and rewards that come from working with the patients.

For the caregivers to be able to maintain their ability to work it is vital that they manage to keep their professionalism and distance while still being empathic and friendly when dealing with the patients and the family.

The caregivers working with the patient would soon be burned out from stress and have harder time to cope with grief/separation issues if the caregiver patient relationship would be compromised.

The working uniform strengthens this identity and it is also important that the working environment does not become too homelike so that it distracts and complicates the work that is performed there.

### The typical workshift (8<sup>00</sup>-16<sup>00</sup>)

#### *Arrival*

Changing clothes

Receiving briefing

Filling up with supplies and medication

Controlling patient state

Doctors round

Biogas testing

Adjusting medication, air supply and nutrition

Patient care/daily maintenance

Lunch (Staff)

Physiotherapy

Visiting hours

Resting period

Staff relief/briefing

Writing journal

*Going home*

### Caregiver and patient relationship

While performing treatment, therapy and diagnostics on the patient it is important that they communicate what they are going to do with the patient even if it is uncertain that they understand.

This is both for the caregiver that can feel abusive or intrusive when handling a patient that are in not in control of their actions and depending on the caregiver. It is also for the patients who are sensitive and can become stressed or feel victimized if they do not know what is happening.

### Caregiver and family relationship

When the caregivers are facing the family they have to be reassuring without giving false promises.

If the visiting relative seems comfortable enough it's good to encourage them to take part in the treatment with tactile stimulation so that they do not feel alienated and provides social stimuli for the patient.

This is also part of preparing the relative to handle the patient in the home rehabilitation in the future.

## Relatives perspective

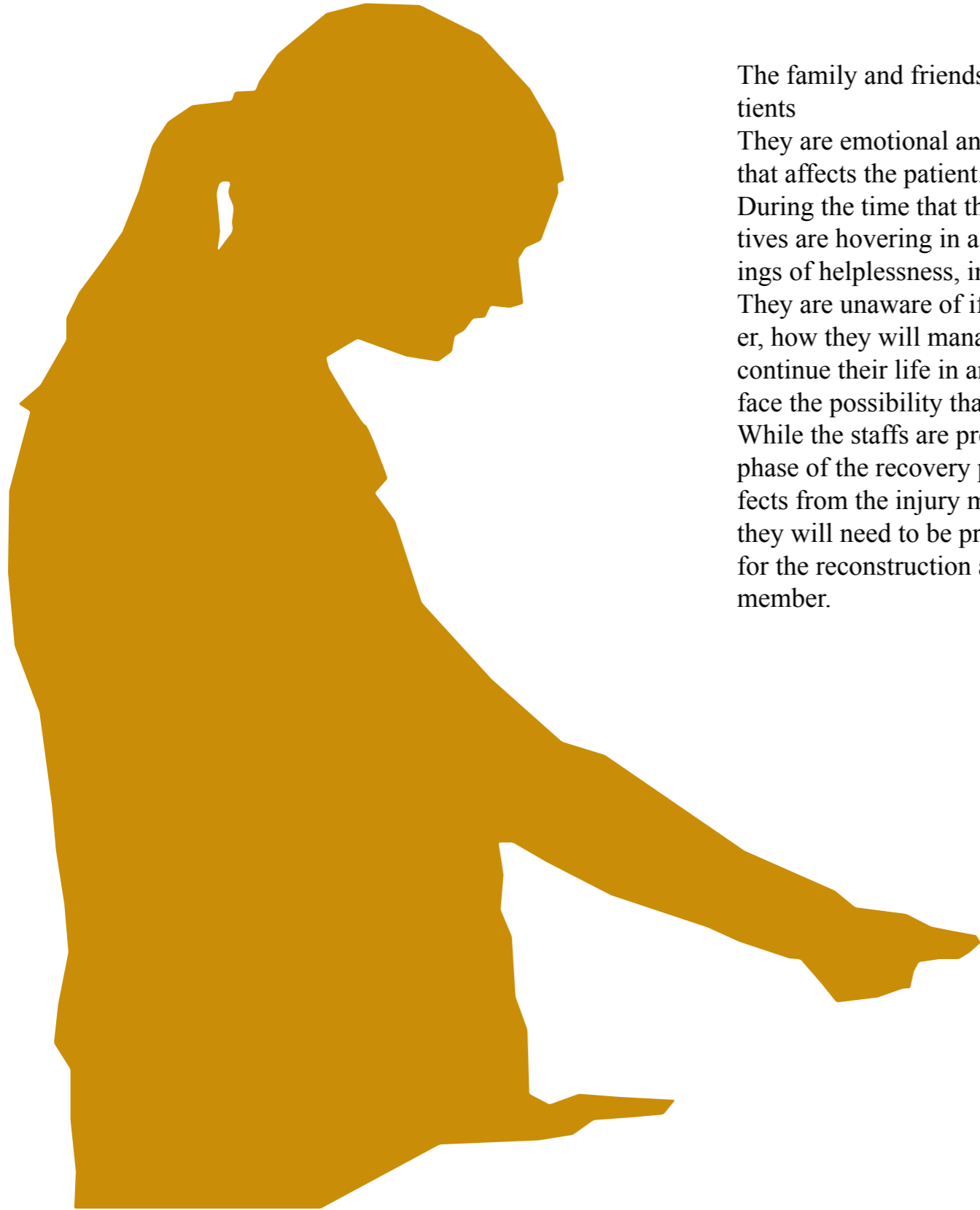

The family and friends are the anchors and lifelines of the patients

They are emotional and psychological victims of the same injury that affects the patient.

During the time that the patient is being at the hospital the relatives are hovering in a state of unknowing that can cause feelings of helplessness, inadequacy and alienation.

They are unaware of if and to what degree the patient will recover, how they will manage economically, will they have be able to continue their life in an ordinary manner. They will also have to face the possibility that their loved ones might not make it.

While the staffs are present during the first and most fragile phase of the recovery process the family will be dealing with effects from the injury most likely for a long time. This means that they will need to be prepared with knowledge and emotionally for the reconstruction and rehabilitation of the affected family member.

In the treatment of patients at the Neuro ICU in Sahlgrenska the staffs is incorporating the visiting family in the parts of the treatment where they can participate. For instance they are used to give non-medical assessment of patient consciousness and to provide social and tactile stimulation.

The patient condition and the life support machines in the room can cause a lot of stress to the visitor that might feel uneasy to touch the patient or be close to the machines.

They are as much as the patients and staff in need of fulfilment of sense of coherence. To cope with this stressful and life altering situation the comprehensibility (to understand the situation), manageability (to feel that you and the patient will make it) and meaningfulness (be motivated to help the loved one recover and to envision a happy life together).

If the visitor are over stressed it might transfer to the patient who are even more unaware of the situation and needs comfort and encouragement from their family.

# Experiencing the ICU environment

The ICU treatment room are a completely different experience from other rooms that affects both visitors and patients in a very sensitive state. There are several phenomenological studies on the subject of how the patient and visitors perceive and are affected by the intensive care environment. The studies are usually based on interviews that in the patients case are performed after they have left the hospital.

## The Patient

The patients memories of the hospitalisation are often diffuse and fragmented but can come back when time passes. Patients on post surgery ICU often recollect their time at the ward as being an continuous dreamstate where the boundaries between dream and reality are blurred. Real events and sounds are weaved into the vivid dreams and affects them in good or bad ways. Small things like perforation of ceiling tiles can in dreams become holes that maggots crawl from or the ticking noise of a machine be interpreted as someone sitting in the room and using a slide projector. Even if most patients are often disturbed by the noises from machines and people in the room it is also a source of comfort increasing the feeling of being safe. That there are people in the room that would notice if something was wrong or that the machines are functioning properly. One patient felt scared to death when a signal started beeping while listening at sound of the ventilator. Patients often feel loss of self control, depersonalisation and lack of life context while being in the partially unconscious state.

## The Relatives

Friends and family members that visit the patient for the first time since the stroke are usually stressed by the experience of being in a heavily equipped hospital room. Often can the equipment in combination with the sterile hospital design obstruct social interaction and make it difficult to feel private and affection. But the technical equipment can in some cases be perceived as something positive that many of the relatives expressed a lack of stimulation while being in the room, wishing that there was something to look upon on the walls and ceiling or a window so that they could look outside. Relatives in one study pointed out that they perceived the corridors outside the room as part of the room experience. A pleasant corridor with paintings on the walls can increase the welcoming feeling in the room.



# Evidence based design

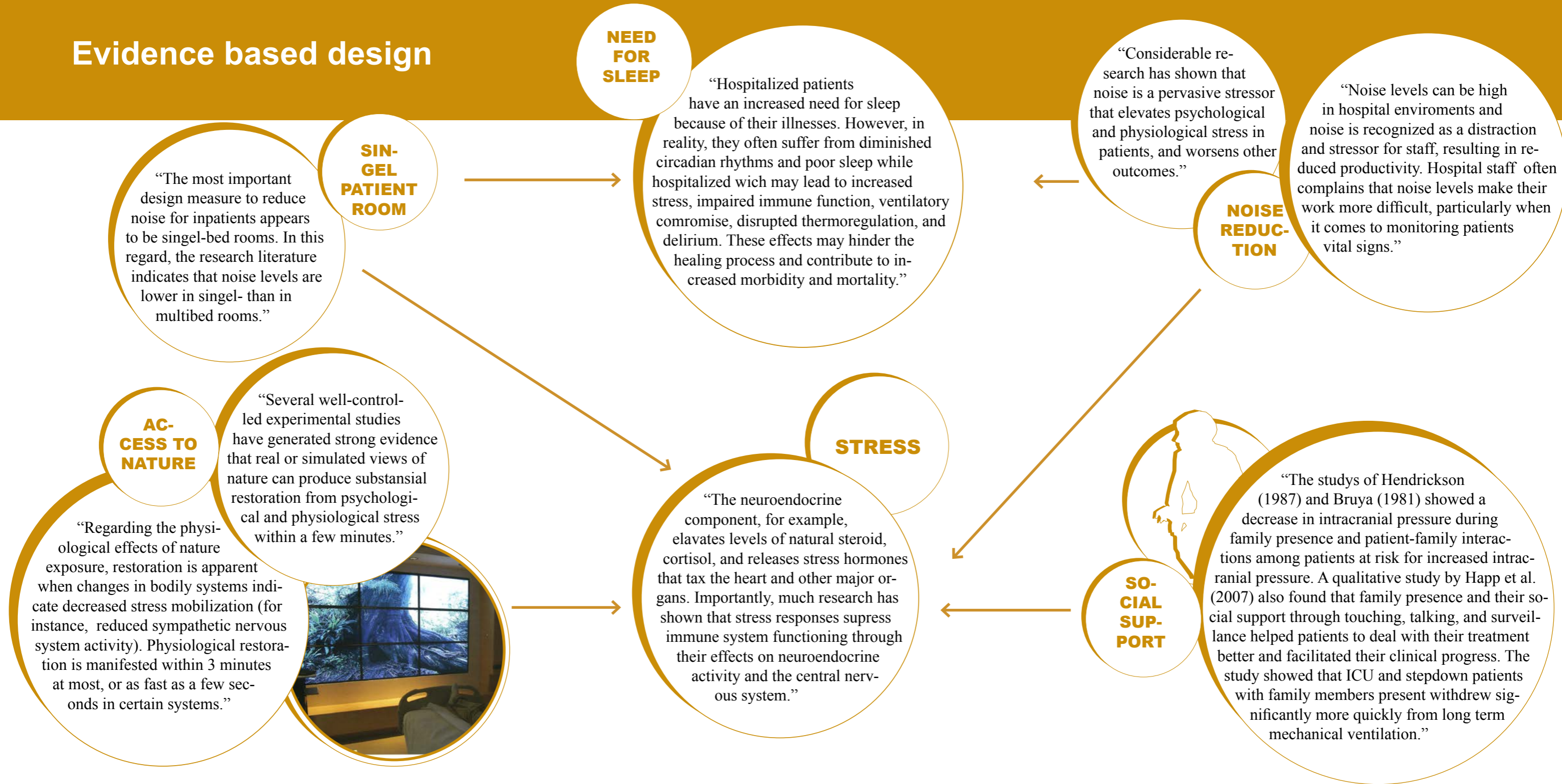

Evidence based design can be described as the methodical usage of previous clinical research within subjects relevant to the design

This term is usually used in the context of the design of healthcare facilities but can be applied in most fields where science can improve the performance of the building.

In the area of commercial development the design process are driven by research of consumer habits, target groups etc.

Within the field of healthcare design the target is to find factors

that improve healing decrease the spreading of diseases and reduce stress for the users.

One of the problems that you encounter when approaching the subject of evidence based design is the data contamination that can occur when you make some environmental changes it can cause ripple effect which makes it difficult to differentiate which factors it is that has produced the specific effect.

For instance if you change a ward to single bed rooms it decreases the spreading of diseases but it could also be the effect

of the individual bathroom that comes with the new room. Most elements examined in evidence based design causes multiple positive or negative effects.

When reviewing the findings received from the healthcare related research in evidence based design some key elements brings forth the most apparent positive effects on the patients most basic needs, sleep and relaxation.

Singel patient room, access to nature, social support and noise reduction are factors that can sustain these.

# Analysis

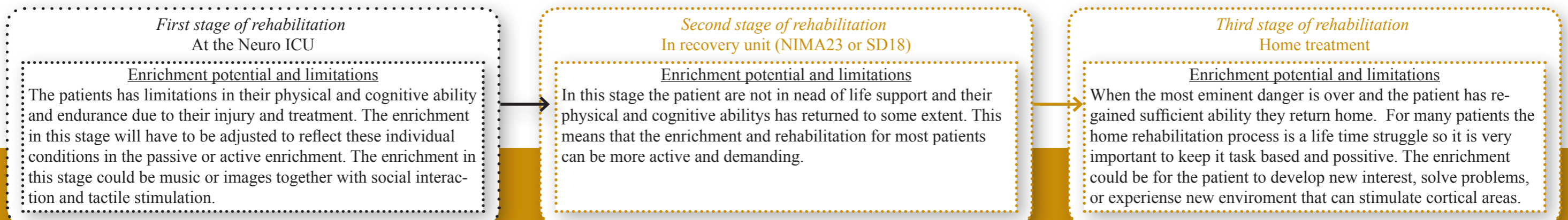
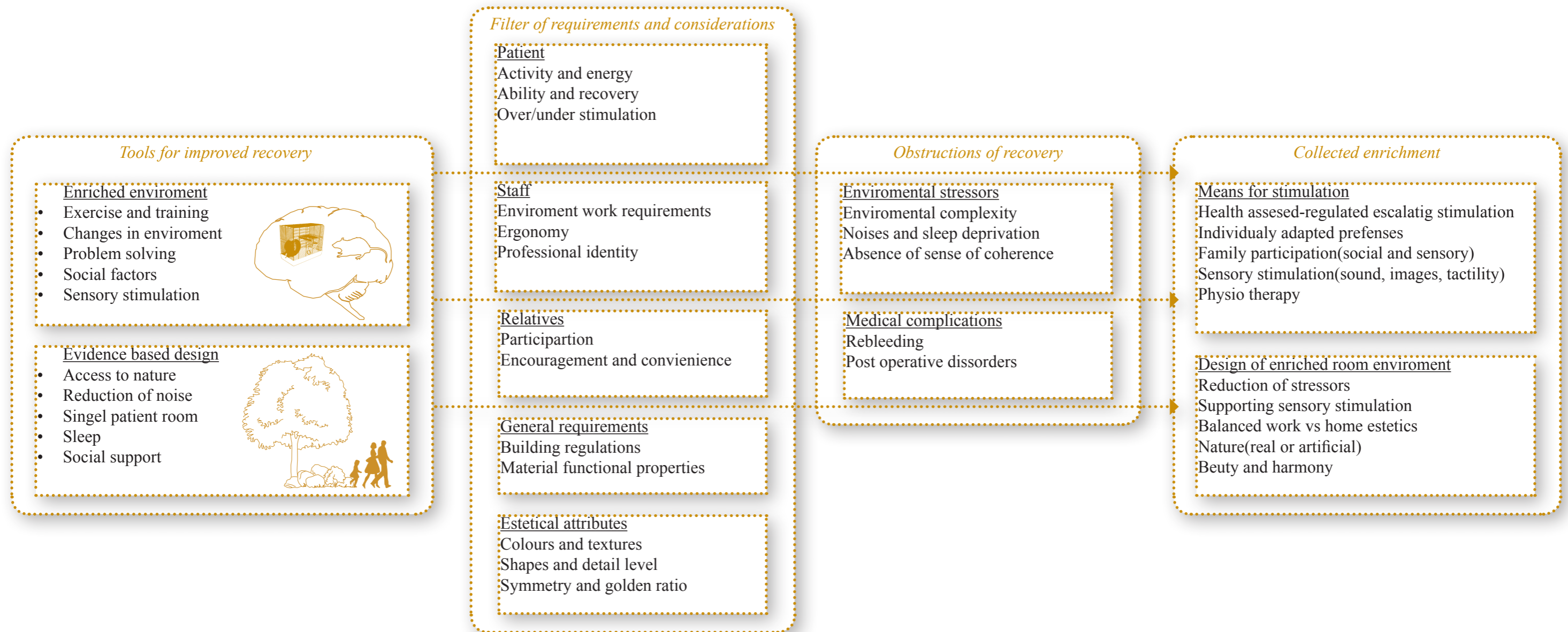



# Machines



There are two ceiling mounted mechanical arms carrying racks of machinery for each patient.

On one side there is nutrition and medication that can either provide gruel and liquid medication from the nose into the stomach (Percutaneous endoscopic gastrostomy) or nourishment and medication by liquid form into the blood system (Intravenous therapy).

The other rack of machines is connected on top of the inner ceiling with the survey station and provides all data viewed on machine to the station as well. This rack consists of two machine systems one that monitor heart activity and the other is a medical ventilator with monitoring of vital data. This system has to be extremely reliable (energy supply). Patients using medical ventilator can never be unattended since if there is a respiratory failure lack of oxygen will within minutes cause brain damage.

The medical ventilator system has a lot of different alarm signals that can be triggered quite often if the patients are unrest full and moves in the bed.

When the patients is moved the nutrition, medication and the oxygen are taken down from their mount and put on a rack that comes with the transportation bed.

In the rooms right now the machines are usually retracted against the

wall as long as there is no need to access the patient head from the back side.

There are several different solutions that could be used for storage of the machines. They all come with their variety of advantages and weaknesses depending who is the observer or user.

-The current solution with ceiling mounted arms has the greatest flexibility but can be visually disturbing for both patients and the relatives. The visual impact could be reduced by adding retractable curtain between the machines and patient.

-The machines could be mounted into a fixed headboard behind the patient bed but this would less flexible and functional then previous solution. It would also have to be easily accessible to change machine settings and to detach the oxygen and nutrition when the patient is moved. This solution could alleviate the visual and noise disturbance from the machines.

-A third version that would be a settlement between the other two could be to build the machines into furniture with wheels that can be moved and placed where it is the least disturbing.

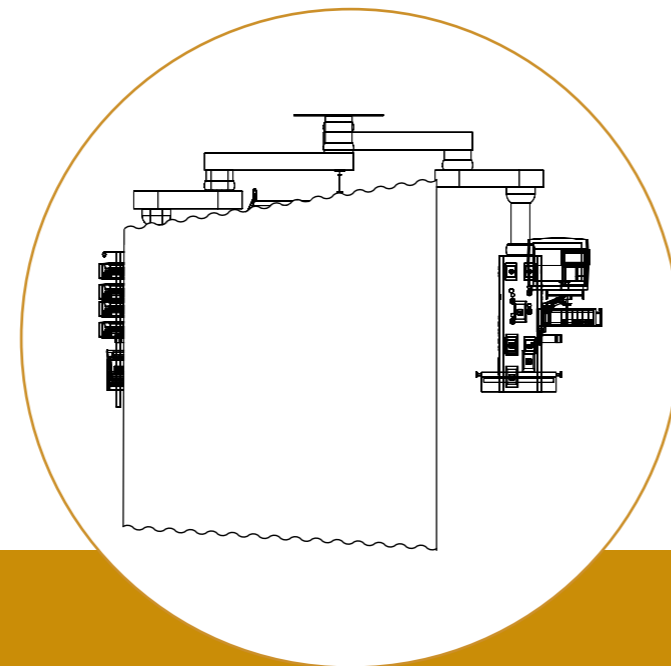



# Outside

Bringing nature quality's closer to the patient has as indicated by the research from evidence based design many healing and stress relieving quality's. At hospital wards in general the indoors vegetation are limited and problematic since it brings earth germs into the environment and can trigger allergic reactions. In some place this can tolerated if the patients are in no immediate risk but this is not the case with any surgery departments. The vegetation could be artificial like the use of plastic flowers (would be hell to clean thou) or images of forests and still have a positive effect.

I would rather have a window towards a real green garden outside then the supplement but the one does not necessarily exclude the other.

Well the problem is that it is not very green outside, it is as ungreen as it can be and nothing worth bothering to look outside the window for. I propose larger windows that reach further down with angled niches so that the patient gets a better view when wanted.

The roofs could be planted on and in the yard outside perhaps a fountain could be the centre of the garden created.

Vines climbing espaliers covering the facades makes sure that the view reaches even those who cannot leave their beds to see it.

A solution that can bring the nature closer to the patients that might not be able to leave their beds is to invest in some flower boxes that can be hanged outside the patients windows.

The disadvantage of this is that the boxes would need an automated watering system that can be quite expensive.

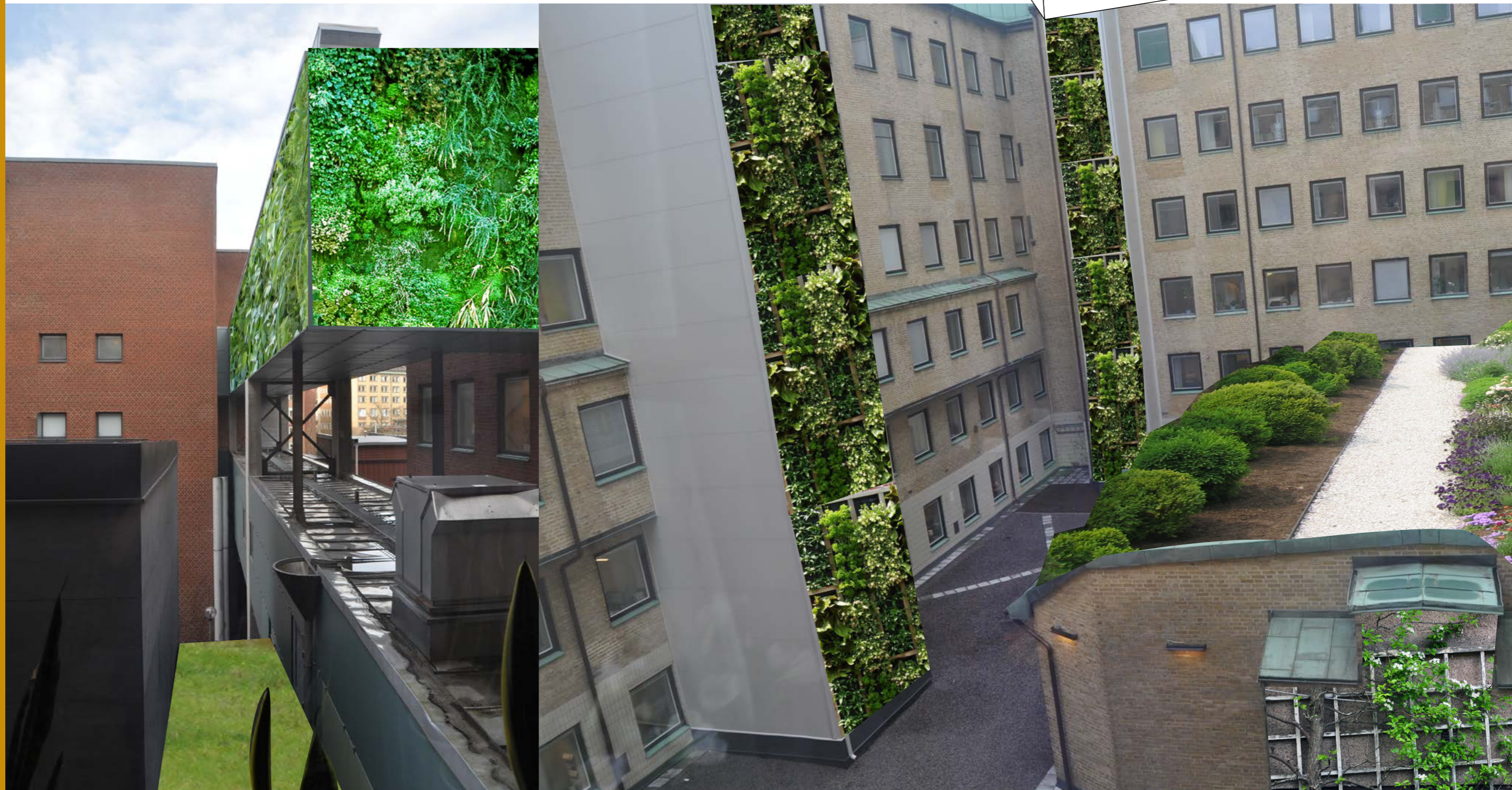



# Lights and sound



At the neuro ICU at Sahlgrenska they have currently a sophisticated light system that both creates a pleasant light setting and have all the functional requirements fulfilled. The patient can be light sensitive when recovering from stroke which limits the possibility to daylight and requires a light setting that works with indirect light without glares. To counter the lack of day light they use a control system that can mimic the change of light during the day which are important for the circadian system that controls hormones, metabolism and can also influence the comprehensibility aspect of “sense of coherence”.

During specific hours the staff turns on relax setting and becomes dimmed so that the patients can rest.

When emergency occur and the patient’s life is at stake the staff can turn on the work light that will immediately take a setting optimized for examination and care. The light environment has a very high quality and the light system that will be built in to the experimental room should strive to meet the same requirements. In the treatment there are many elements that can create noise and thereby disturb the patients in need of calm.

Some measures have been taken to deal with this disturbance for instance sound absorbing ceiling materials. There are more that can be developed that would improve the acoustic quality of the rooms.

The room separation of patients could reduce the noise transferred from the neighbour patient visitors and treatment.

Sound absorbents can be placed in the walls.

The alarm sound could possibly be directed away from the patients in a way that would reduce the noise.

When selecting a sound absorbent it is important to both find one that decreases the dB enough and shortens the reverberation time as much as needed.



# Enriching the environment

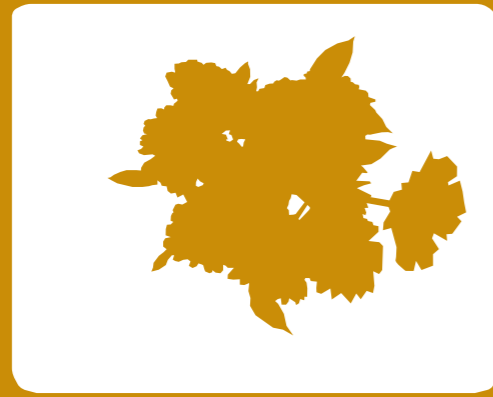

There are limited amounts of research performed on humans subjected to enriched environment. The human being are a lot more complex and unpredictable than rats, which makes it hard to find variables that can be translated as enriched for this purpose. In the few cases where human's subjects have been used, it has shown that enrichment in the terms of the individual has positive effects.

From the experiments on rats we can conclude that several experimental parameters can be considered enriched. Some of these measures requires a physical and cognitive condition that at first are beyond the of the patients ability at the neuro ICU.

The patients are not in condition to leave their beds or participate in any advanced physical activity but some patients has the potential of simple motoric exercises and for most patients the tactile stimulation from staff or family has positive impact.

From the effects of the injury, treatment and lack of sleep most patients are brain tired which limits the amount and type of concentrated stimuli they can withstand. This is also a factor to consider when designing the environment so that it is balanced and stimulating in contrast to overstimulation. To achieve this we need to reduce the visual complexity that the patients are subjected to by moving and turning objects that can be disturbing out of the field of view.

To some patients a media system could be used as sound or image stimulation.

The sound system could be used without consequence for the neighbour if the rooms are separated but otherwise there are pillow speakers that can direct the music, sound of water or nature without disturbing the neighbour.

An image projector or monitor could provide nature images as well as being used together with the relatives that can bring images of their travels, children or life as stimulation. Both the sound and image system has to be used with the supervision and presence of the staff since the patient might not be fully able to protest if uncomfortable by the stimulation. Then the heart rate monitor would indicate the patient stress. At the Sahlgrenska's children's care they are sometimes working with tools for stimulation. The neuro ICU once borrowed a blanket made of balls (used for creating a feeling of where the body ends) to a patient but they did not receive any specific positive effects.

Similar stimulation of the tactile sense can be performed, for instance at the Borås ICU department they tested a new environment to counteract the machine intensity. In their room they improved the material quality of the bed linen to satisfy the patients.

An alternative could be to have different type of gloves with different texture and materials.

If the patient receives mechanical help with breathing the nose or/and mouth are occupied and cannot be subjected to scents and flavours. But in the last days at the neuro ICU some patients can be released from the breathing life support and they could possibly enjoy the smell of a cinnamon bun or

some drops of their favourite beverage at their tongue.

The social factor within the experiments performed on rats proved to be important which suggests that reinforcement of the relatives roll in the recovery would suffice as stimulation. In the current treatment room there are only an folding chair that indicates that the relatives belongs in the room and has a place there.

To shift some of the balance in the room from being only a work environment to becoming somewhat more of hybrid between work and life which can enhance the roll of the relatives and make the patient feels more relaxed. If this is done it must be performed without compromising the performance or wellbeing of the staff.

It is also important for the patient that even if the environment are more homelike that it can be understood as an hospital so the patient does not become confused or afraid that their relatives has left them in an apartment after the injury. Stimulation directly after injury has proven a greater effect on the recovery then in the cases where the stimulation starts later on.

But some of the features that were tested efficient on rats would require a further rehabilitated patient, like for instance the problem solving aspects and the constant changing environment.



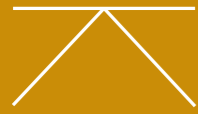

Perspective

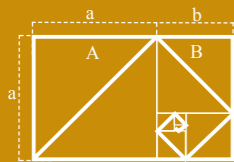

$$\frac{a}{b} = \phi = 1.618$$

Golden Ratio  $\phi$

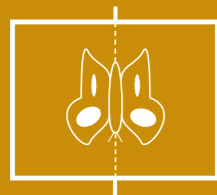

Symetry

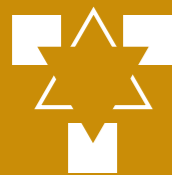

Abstract vision  
(Kanizsa diagram)

The difficulty about aesthetics as subject is that it is in most of the aspects very individual and the opinion about it is connected to the observer's memories. Some styles and colours are considered represented more often as positive and calming and thereby often used in healthcare environments.

Bright and soft greens, blues and earth tones are often used there.

The two colours opposite to each other in the colour circle are considered to be a contrasting pair and most pleasing in combination.

Within the evidence based design there are concerns about using arts and aesthetics that contains strong expressions and abstract complexities since it often can have a negative effect on patients. These types of arts have a very unpredictable side and can produce a wide range of different experiences and associations. Roger Ulrich mentioned an example in one of his lectures at Chalmers; that the staff had print in a room of some abstract, cute silhouette apples that liked while some of the patients experienced it as being laughing skeleton skulls. (Not very nice in a hospital environment)

Despite the subjective experiences of aesthetics there are actually some facts within the aesthetics that corresponds to discovery's in neuroscience, this subjects is called neuro aesthetics.

**Symmetry** is one of the neuro scientific factors that have been researched. Most people experience perfection and balance by symmetry, this can have calming effect when used in a health-care setting. We understand objects and room faster when they are symmetrical; it also means that we do not need to see the whole to understand how it is.

The human eye can sense symmetry in an object as fast as 0.05 seconds this means that we can sense symmetry faster than we can process it. This implies that the symmetry reading part is a hardwired in our brains. One theory suggests that our ability to read symmetry is primitive and has the origin in our ability to differentiate non symmetrical landscape or nature from possible living threats like animals.

The **golden ratio** can be described as harmonically arrangement of parts and proportions that most people find pleasant. The ratio is the relationship between the long and short side of a building or object in 1/1.618.

Since this is so commonly accepted there are scientists that believe that these aspects also are hardwired and come from our primitive heritage.

Our **visual intelligence** is using a large part of our brain and it is the grammar of rules set to guide us when reading our environments. It is similar to learning how to read text but are developed a lot earlier.

These rules are used and manipulated when creating visual art to make us experience a virtual room or shape.



Overstimulating shape complexity.



Materials with tactile qualitys like textiles and wood can improve the room experience .



Overstimulating colour setting.



Relaxing bright colours and materials.

# Three possible conversions

## Limited change

- Dividing the treatment room with a wall and adding a folding wall

### Benefits and disadvantages

It is the cheapest solution and there for it does not bring many privacy and quality. The wall in the middle would not work when the patients are coming and leaving since they need to fit in an transport bed and have enough space to work.

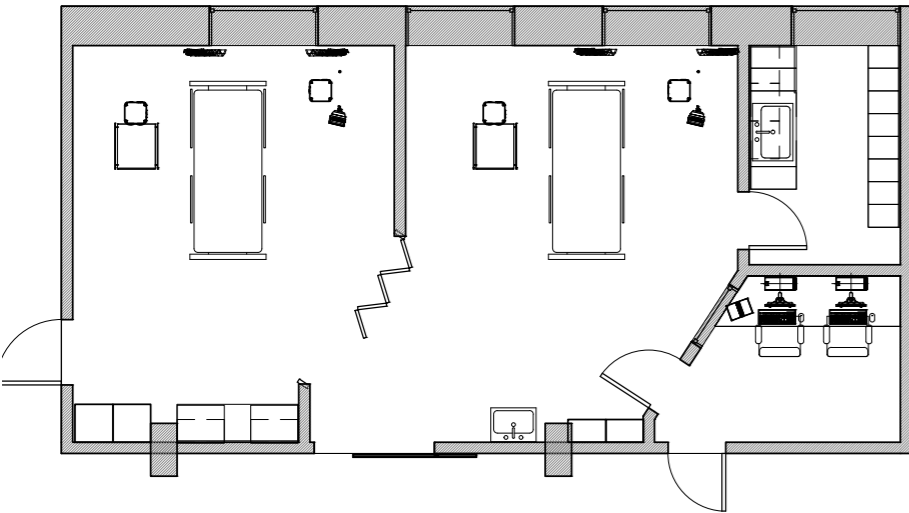

## Moderate change

- Dividing the treatment room by centralising the survey station and rinse room.
- Rotating beds and integrating the machines.
- Changing two windows

### Benefits and disadvantages

Acceptable costs with advantages of good privacy and reduced noise transfer between patients. The survey station in the middle gives closer contact with the patients.

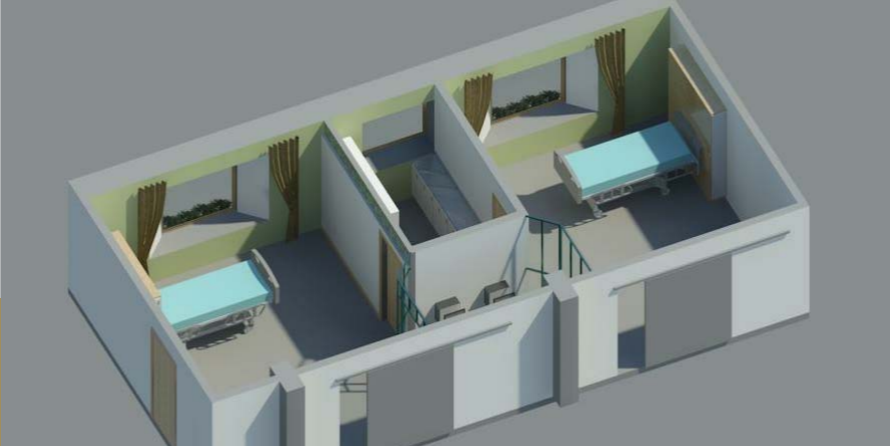
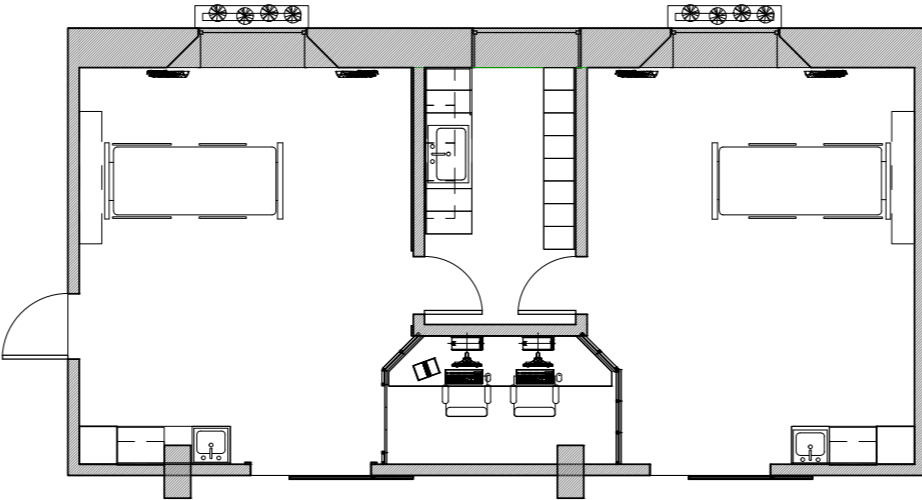

## Extensive change

- Dividing the treatment room by centralising the survey station and rinse room.
- Rotating beds and integrating the machines.
- Changing the entire wall
- Adding a balcony

### Benefits and disadvantages

This solution has the quality of previous room but are probably to expensive since the increased space and balcony has required a complete demolition of the exterior wall.

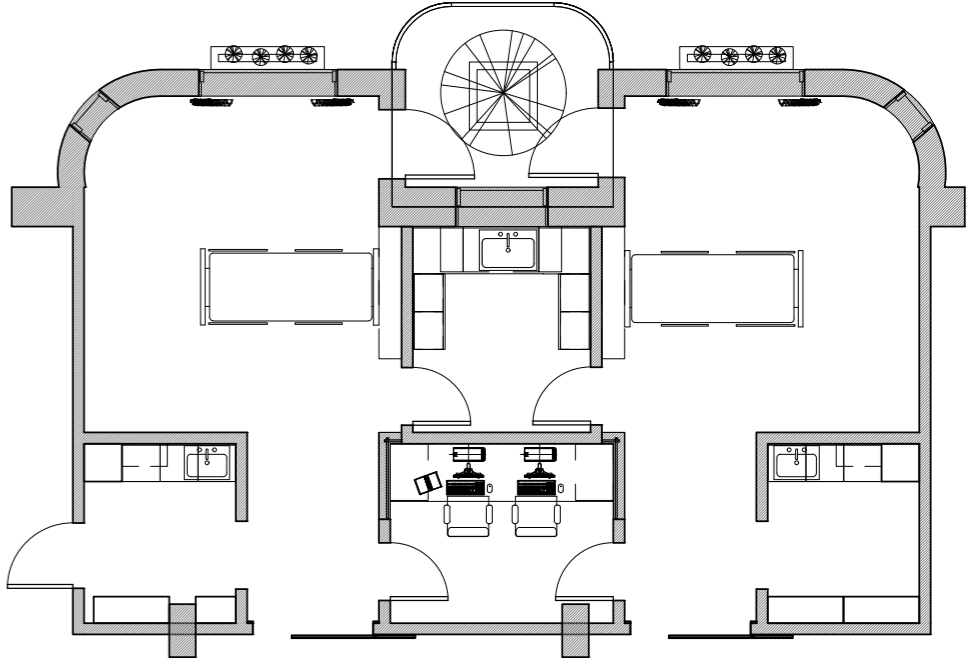

# Developed plan proposal

Treatmentroom  
 4.Organising machinery and visually disturbing elements outside the field of view to create a side of calm enviroment.  
 5.Media(audio/video) system that can be accessed from the monitorstation so that the staff and family can bring music and photos to show the patient. The system design should be integrated with enviroment to avoid disturbing details and cords.  
 6a.A window niche that can be used to store a visitor chair. Outside a flower box brings some nature into the view.  
 6b.A larger window with seating and storage possibility.  
 7a.Ceiling mounted mechanical arm with nutrition and medication.  
 7b.Ceiling mounted mechanical arm with breathing support and heart monitoring system.

3. Hygiene/Rinsroom  
 The rinsroom divides the room and can be opened if the conection is needed. This gives the the patients and their relatives a higher degree of privacy and intamacy but also decrease the sound from the machines and communication that is not targheting them.

1.Corridor  
 Folding seats with wall tray for magazines and information brochures.

2. Monitoringroom  
 The room should be glassed toward the treatment room allowing both staff and the patients to see each other as well as an window to the rins room to conection to the outside from then room.

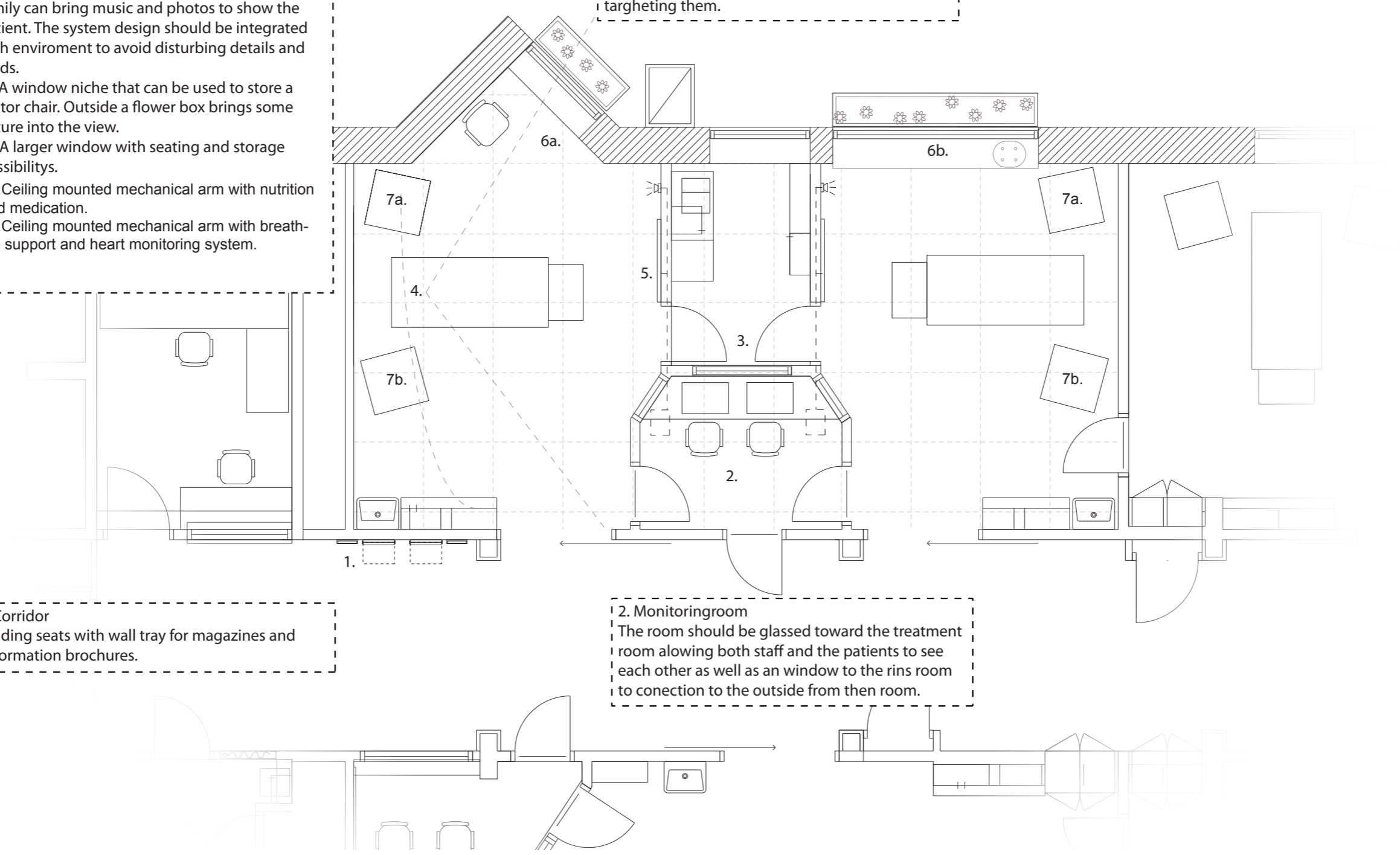



# Department feedback

From a discussion with the head of department at the neuro ICU department at Sahlgrenska I realised that some of the design decisions in my proposal had slipped from reality and now lacked foundation.

The key elements that needs to be reconsidered was,

With the current staffing amount that works in the treatment rooms it is not possible to make full division between the patients residing there. Since the nurses need to be able perform treatment on one patient while maintaining a direct visual and auditory connection the neighbouring patient.

When the patient are leaving the neuro ICU they will be in a more stable state of health and require less monitoring in which case the separated solution could be used.

They also expressed concerns about whether the patients were in a condition to benefit from visual stimulation by media system.

We had a short discussion about if a machine integration of some kind would be possible and they did not object to it but were not sure if it would be better than the mechanical arm system they are using.

*I have abandoned the position of completely divided room and will instead developed a mediating version with separated patient/visitor entrances but with a partial wall that can fulfil the working requirements but still enhance the impression of individual space and reduce the noise contamination between patients.*

*I maintain my vision that the patients and visitors in some cases can be using the media system as stimulation.*

*I have still not come to a definitive decision about if the benefits of machine integration can counter weight the flexibility that the mechanical arms provide.*

# Revised proposal

Increased window height and angled niches for improved contact with the outside

A dividing wall with a glass sliding door that can be closed when visitors request privacy. Inside the wall there can be storage possibilities for patient and relatives.

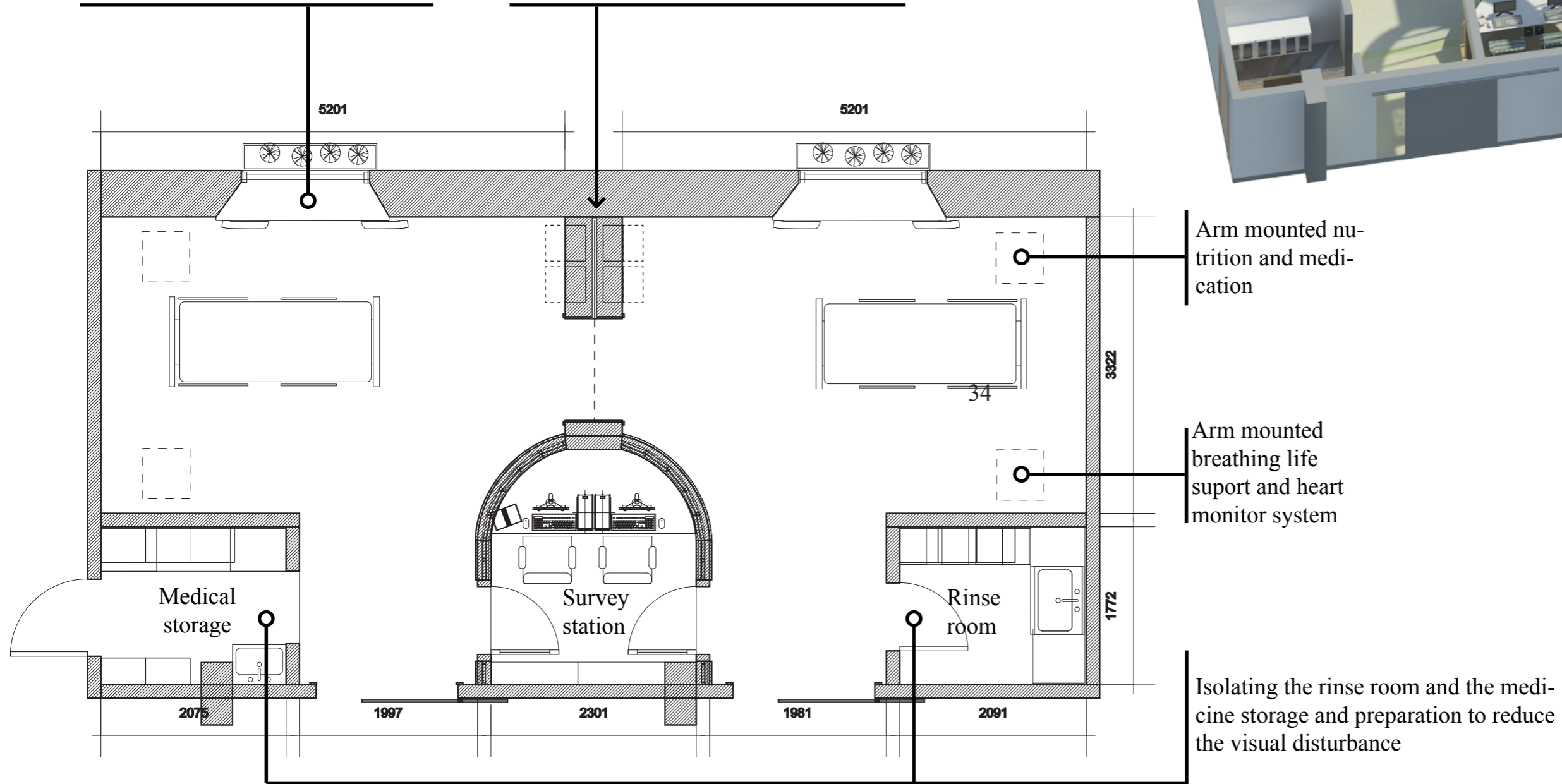
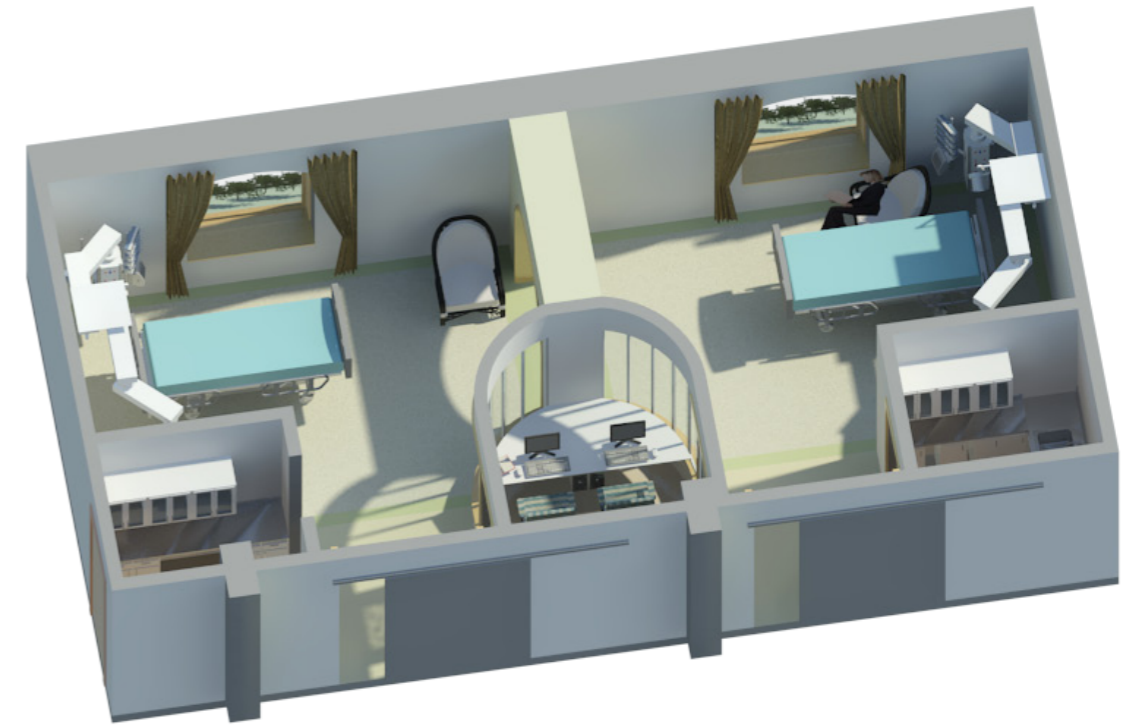

# Ceiling

Spotlights bouncing indirect mood light against the walls. Can be connected to similar circadian system that currently being used or multicoloured led lights that can enhance moods in the room.

Ceiling mounted worklight that can be used in different settings

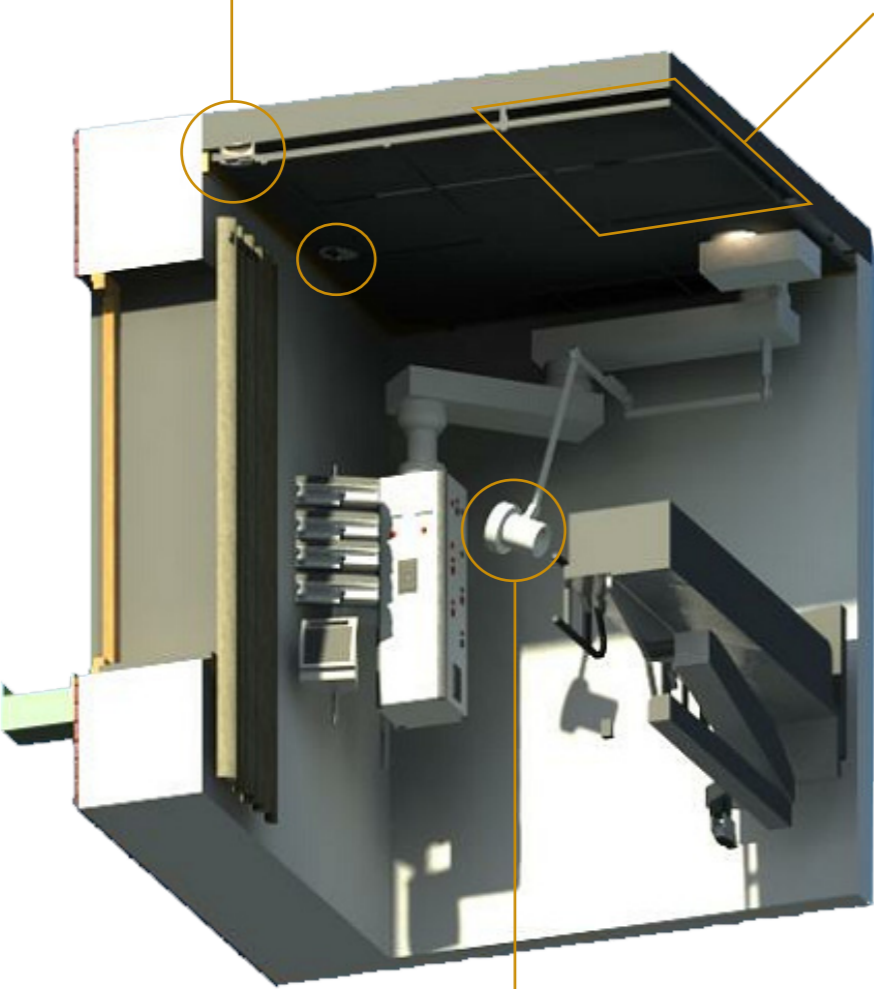

Arm mounted directable worklight for close observation and testing pupil reaction.

View from the room entrance



Ceiling holding installations with a symmetric square pattern. Following the recommended hygiene classing 2 in (BOV) which means it should be nonperforated plates without gaps that can be wiped clean. The sound dampening should be as recommended for ICU according to the (BBR),  $T_{20} < 0,5s$ . For example the Gyproc Gyptone Base system.



# Furnishing



View from the survey station

Material finishes and details with wood or wooden imitation can increase the perceived warmth of the room and counter the feeling of being in an institution. Textiles and curtains can further improve these qualities as well as soaking up and reducing noise.

Several of interviewed relatives emphasised the importance of the chairs in the room. The chair can have a symbolic importance that communicates the intended roll and place for the relatives in the care process. An folding chair can be interpreted as that the visitor are trespassing and only has an temporary place in the room while an comfortable chairs that fits esteticly with the rest of the environent communicates an intended space and roll for the visitor.



View from the patient bed

# Sections

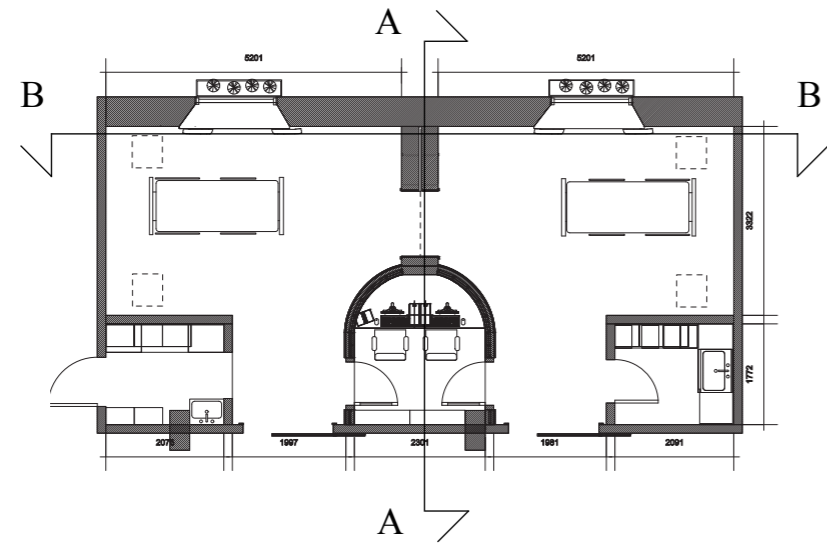

Section A-A



Section B-B

## Media system

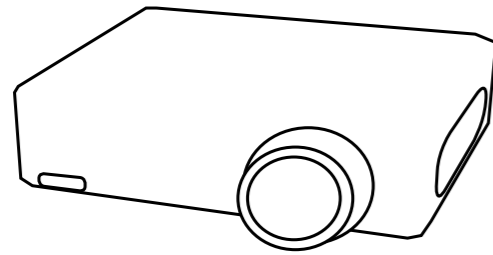
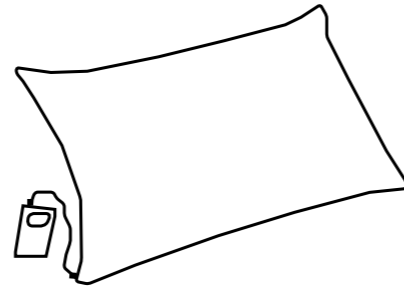

Image projector



Pillow speakers



A media system with audio speakers and image display can be a tool for enrichment if the patient has recovered enough. But it is important that the media stimulation is controlled and surveyed by the staff since it is important to detect signs of over-stimulation and stress within the patient. If the system is easily accessed with for instance a direct usb connection, the relatives can bring music that the patient like or images of memories that they share with the patient.

Displaying media in the ceiling can for some patients be easier to watch then on to the wall. Other patients might feel that it can be disorienting since we are used to view media in the other direction.



Multi coloured led light system can be used to easily change and enhance the atmosphere of the room.





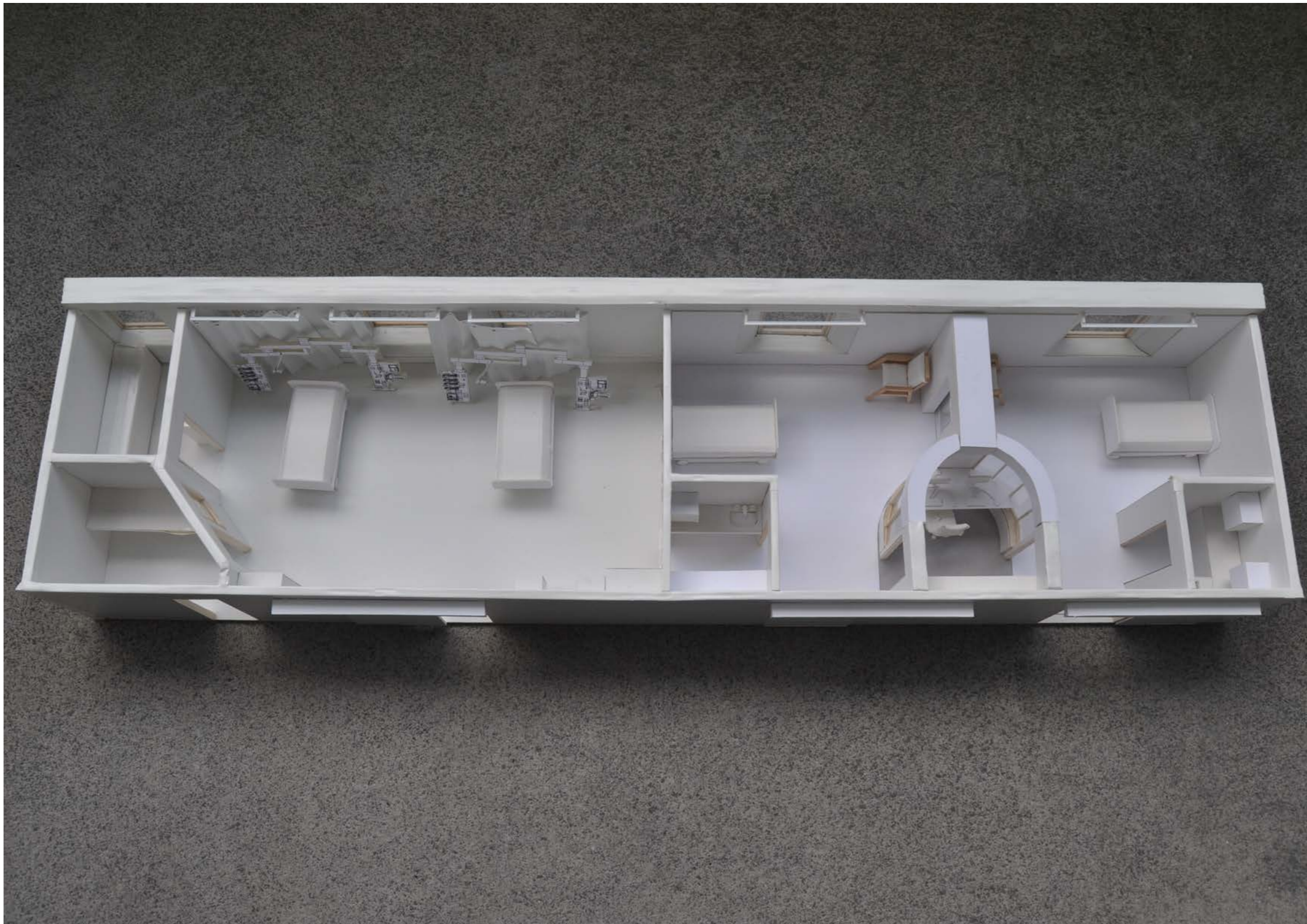

Model photos



# Conclusions

## The interdisciplinary study

It will most likely take a few years before we can see the outcome of the study about the effect of directed multimodal stimulation in intensive care since there are many actors involved and many time consuming details to resolve.

When the study is finished it can provide us with important answers about how enrichment can be used within the rehabilitation from brain damage and healthcare in general as well.

## The proposal of the room design

When it comes to the design of the Neuro ICU room that could be used for enrichment I have worked my way down to a few constituents that corresponds to the patient capability in this phase of the recovery.

### **Social interaction**

Empowering the presence of relatives in the room and increasing the privacy will make the visiting family members more relaxed and prone to engage in social interaction with the patient. Their presence will provide feelings of safety and orientation as well as stimulation that can improve the recovery.

### **Reduction of unnecessary stimuli**

If we are to subject the patients to add directed sensory stimulation it becomes important create an resting environment that has dimmed away noises and confusing or distracting elements so that they will have the endurance to receive the directed stimuli.

### **Individually adapted enrichment,**

Each patient has their own individual preferences of what is calming and stressful. They can also be in different stage of the recovery process than their room neighbour which makes it important to minimize the unintended transference of directed stimuli between different patients.

The family and friends can be a good source for finding these individual preferences.

## Reflection

The concept of enrichment in our lives raises questions how much enrichment we are actually giving to ourselves. In a 9 to 5 office job followed by being locked inside our apartment for the rest of the evening in front of the television, we become spectators of life. This kind of isolated lifestyle that mainly propagates in the rich part of the world cannot be considered enriched but rather impoverished.

The amount of space we are dedicating to our homes are constantly expanding perhaps we should focus more on the quality outside our homes where the social interaction takes place.

When we get stuck in some problem that we cannot resolve we would benefit from taking a break and experiencing something different and exciting instead of just going into the problem as we often do. The change of environment or experiencing something that we never tried can develop the circuitry connection necessary for the solution that we seek.

# Sources

## BOOKS

- J. Zeisel, *Inquiry by design*, 2006  
H.F. Mallgrave, *The architect's brain: Neuroscience, Creativity and architecture*, 2011  
J.P. Eberhard, *Brain landscapes*, 2009  
A. Antonovsky, *Hälsans mysterier*, 1987  
J.B. Taylor, *Min stroke*  
A. Stevens, J. Lowe, *Pathology: Second edition*, 2000  
A. Landen, T. Andersson, *Närmiljön runt patientplatsen: hur kan den utvecklas*, 2006

## ARTICLES

- K.Sahlqvist, *Forskningsprogram: Effekten av riktad stimulering vid intensivvårdsbehandling*, 2011  
K.Sahlqvist, P. Lindgren, M. Nilsson, *Rapport om konstnärliga utvecklingsprojekt: Design och neuroforskning*  
B.B. Johansson, *Brain plasticity in health and disease*, 2004  
M.C. Diamond, *Response of the Brain to Enrichment*, 2001  
B. Will, R. Galani, C. Kelche, M. R. Rosenzweig, *Recovery from brain injury in animals: relative efficacy of environmental enrichment, physical exercise or formal training*, 2004  
S. Olausson, et al. *The ICU patient room: Views and meanings as experienced by the next of kin: A phenomenological study*. *Intensive Crit Care Nurs* (2012), doi:10.1016/j.iccn.2011.12.003  
L. Johansson, et al. *The sound environment in an ICU patient room-A content analysis of sound levels and patient experiences*. *Intensive Crit Care Nurs* (2012), <http://dx.doi.org/10.1016/j.iccn.2012.03.004>  
B.S. Cypress, *The lived ICU experience of nurses, patients and family members: A phenomenological study with Merleau-Pontian perspective*

## MEDIA

- ANFA - Academy of Neuroscience for Architecture, [www.anfarch.org](http://www.anfarch.org)  
F. Gage, *Neural Plasticity and Diversity in the Adult Mammalian Brain*, [http://www.youtube.com/watch?v=8\\_tWbSdzBHU](http://www.youtube.com/watch?v=8_tWbSdzBHU)  
F. Gage, *Stem Cells and Neurogenesis*, [http://www.youtube.com/watch?v=CeAjZ7AIES4&playnext=1&list=PLJKJ8RSgB5FiVPcvM5RHLL9py6XdGtB\\_g&feature=results\\_main](http://www.youtube.com/watch?v=CeAjZ7AIES4&playnext=1&list=PLJKJ8RSgB5FiVPcvM5RHLL9py6XdGtB_g&feature=results_main)

## IMAGES

- <sup>1</sup> *Innovations in Hospital Architecture*, S. Verderber, 2010: p.25,27,31,39  
<sup>2</sup> *Pathology: Second edition*, A. Stevens, J. Lowe, 2000: p.16  
<sup>3</sup> M.C. Diamond, *Response of the Brain to Enrichment*, 2001: p.15  
*Other images and photos has been created by the author*



