

Uppgiftsbeskrivning

Uppgiften bestod av att rita en opera. Platsen för operan var en öde tomt angränsande till Rue Peel och Rue St Jacques i centrala Montréal. I operan skall finnas en operasal, rum för personal t.ex. omklädningsrum, backstage, kulissverkstad, garderob, perukeri samt lastkaj för in och utlastning av material med lastbil. Det skall också finnas publika ytor i operan som skall användas av besökarna, t.ex. ett café, foajé och entré med en biljetlucka samt information, offentliga toaletter och garderob för besökarna. Det skall även finnas repetitionsrum och övningsrum som både skall kunna användas av musiker för att öva samt användas i mer offentliga sammanhang t.ex. föreläsningar. Operasalen skall också vara multifunktionell, t.ex. genom variabla akustiska egenskaper. Detta för att den skall användas både av universitetets elever och andra besökare för allt från opera och teater till konserter, musik, sång, föreläsningar och annan kultur.

En annan akustisk utmaning i projektet är att avskärma operan från oönskat bakgrundsbuller. Sådant genereras av bil-, tåg- samt flygtrafik från bilvägarna, tåggräsen och flygplatsen som ligger i närheten av tomten. Ljudalstrände rum (såsom verkstad) skall också isoleras från ljudkänsliga rum såsom övningsrum och scen. Detta skall beaktas

både i planlösningsprocessen samt i detaljritningen av till sådana rum angränsande väggar, tak och golv.

En intention var att skapa en byggnad som står ut i sin omgivning så att man ser direkt att det är en kulturbyggnad och blir imponerad av/nyfiken på. Det skall vara en inbjudande offentlig samlingsplats som man kan ha flera olika anledningar att besöka förutom att gå på opera. Besökaren som går till operan för att se en föreställning skall ledas in i ett auditorium med en "magisk" stämning och bjudas på en arkitektonisk upplevelse utöver det vanliga.

Reflektion av metod och process

Skissprocessen bestod först av modellbygge i kartong och övergick sedan mer och mer i digitala modeller. Vi fastnade tidigt i det "vassa" formspråket som syns i den färdiga byggnaden och inspirationen kom från krossade isflak. Utformningen av byggnaden gick ofta till så att vi vred och vände på dessa flak tills intressanta rum bildades. Vi försökte leva oss in i modellerna och diskuterade vilken typ av funktioner som skulle passa in i dessa rum.

Balkongfronterna inne i auditoriet har utformats med hjälp av parametrisk design. Formen på dessa är slumpade, storleken och vinklarna samt hur mycket de sticker ut varierar för att efterlikna skärvor. Utplaceringen och orienteringen av sittplatserna har även dessa med stor framgång gjorts i grasshopper.

Reflektion av resultatet

Sambandet mellan rummen i foajén är jag extra nöjd med. Att man kan åka skridskor under den, men samtidigt ovanför/bredvid utställningsytan är spännande. Att omsluta operabyggnaden med is/vatten tror jag är ett smart drag då det både kommer vara snyggt visuellt med reflektioner samt en extra upplevelse och mötesplats med en isbana på vintern. Formen är väldigt expressiv med vassa vinklar och jag tycker att konceptet tydligt kommer fram. Jag är även mycket nöjd med planscher och dess layout, de känns sköna att titta på.

Om vi hade haft mer tid på oss tror jag att vi hade lagt den på att göra projektet mer "byggbart". Till exempel tänka igenom materialval en gång till och göra fler detaljritningar för att förstå hur komplicerad byggnaden verkligen är samt eventuellt förenkla den något. Projektet skulle även behövt några fler genomarbetade perspektivbilder och sektioner som förklarar delar av byggnaden som inte är helt självklara.

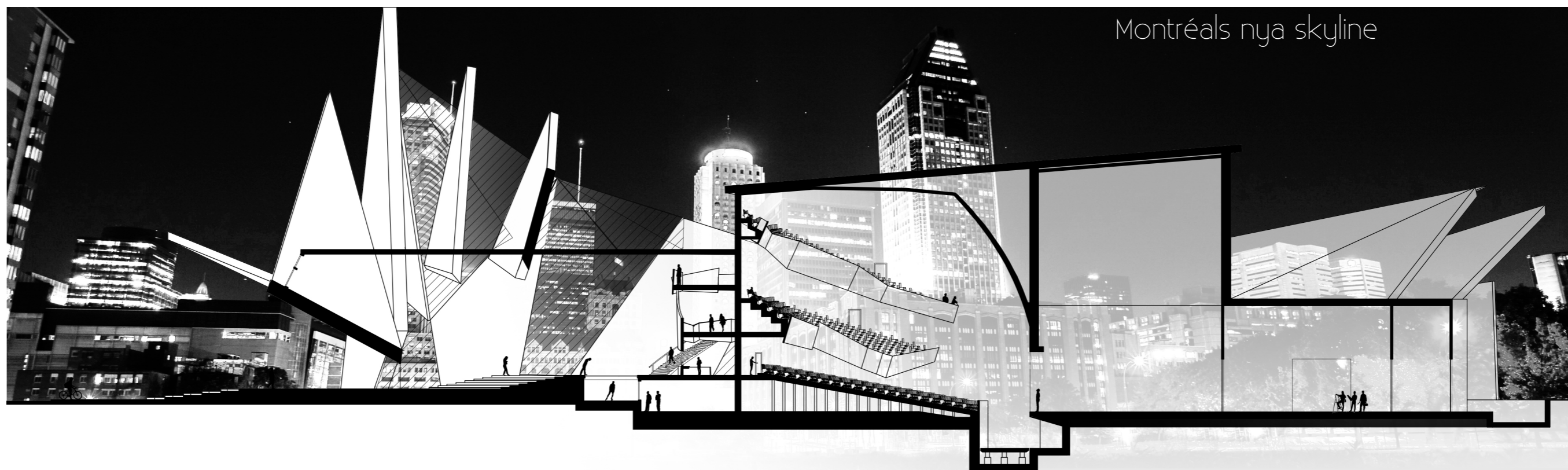

Montréal's nya skyline

Le Tesson

Montreal Opera

plats: Rue Peel/Rue Saint
Jaques, Montréal
tid: vår 2013
kurs: Kandidatarbete, 15hp
kombinerat med studenttävling
examinator: Morten Lund
handledare: Oskar Karlsson, Mendel Kleiner, Peter Christensson
grupp: André Agi, Tor Möller
verktyg: rhino, autoCAD, Id, Ps

Acting as an urban sculpture and a new landmark for the city of Montréal, the opera offers to both citizens and tourists a place for exploration, music, events and activities. The distinctive design along with its magnificent height separates the building from its surroundings and engages the spectator to explore its various heights and revealing geometric meetings.



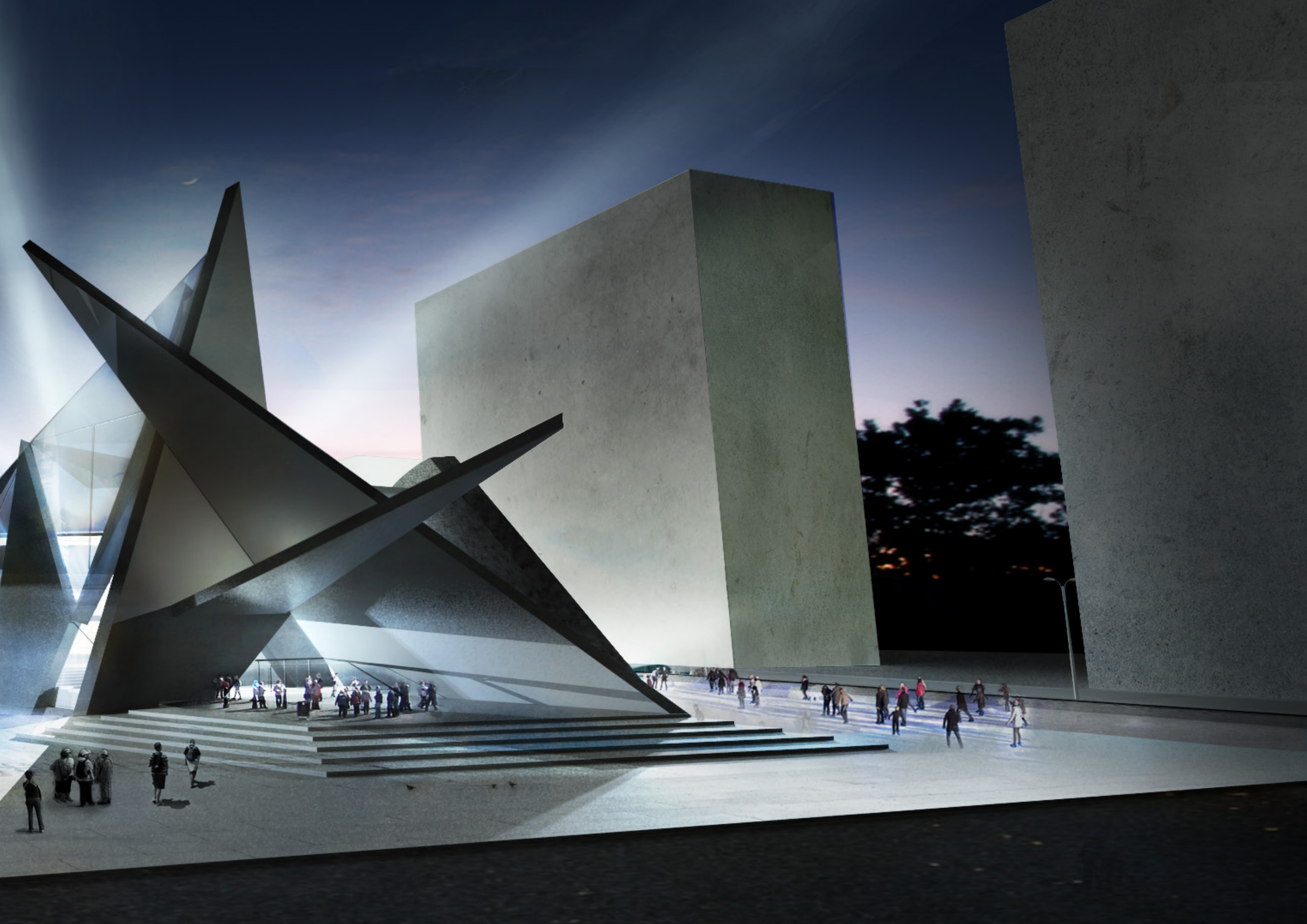

Plans

The opera has a welcoming approach with the main entrance and all attractions facing the open areas to the northern and eastern sides of the site.

The site poses a great challenge regarding noise transmission with multiple external sources such as aircrafts, railroad and traffic. The tesson is accordingly planned with great care to meet the strict noise level requirements.

PLAN 0

- | | |
|-------------------------------|----------------------------|
| 0 Main entrance | 8 Wardrobe |
| 1 Entrance | 9 Rest rooms |
| 2 Foyer (1800m ²) | 10 Water passage |
| 3 Box office | 11 Performance hall |
| 4 Café | 12 Scene shop |
| 5 VIP Lounge | 13 Silent Air buffert zone |
| 6 Rehearsal room | 14 Orchestra pit |
| 7 Storage | |

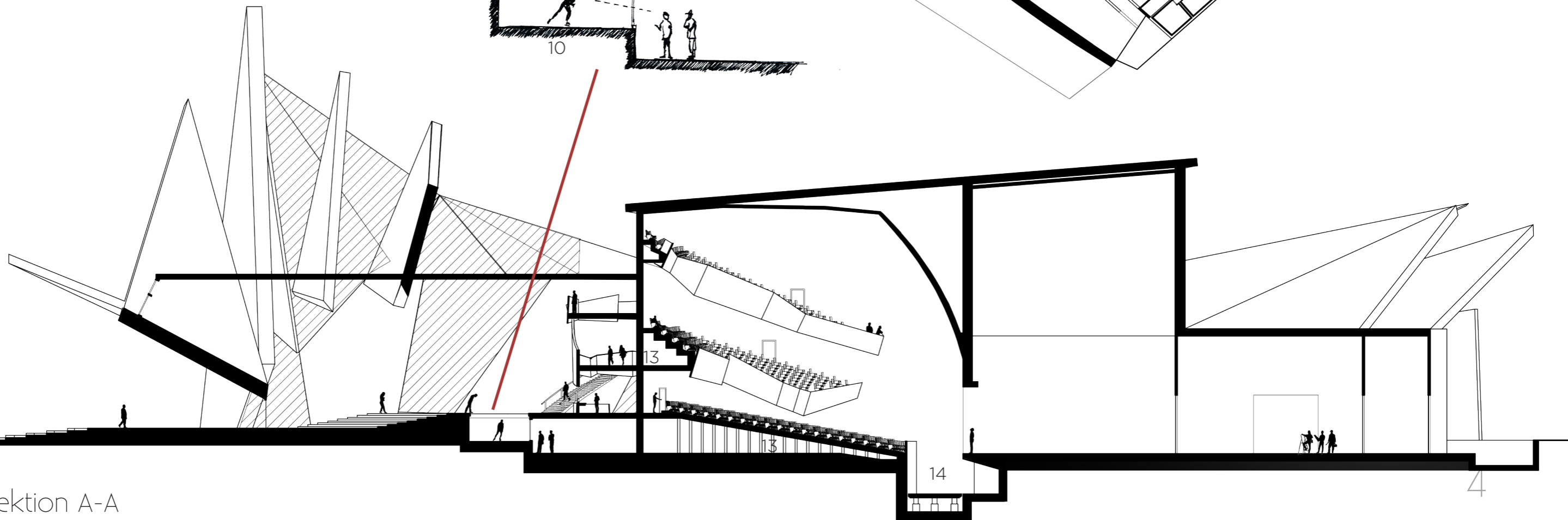
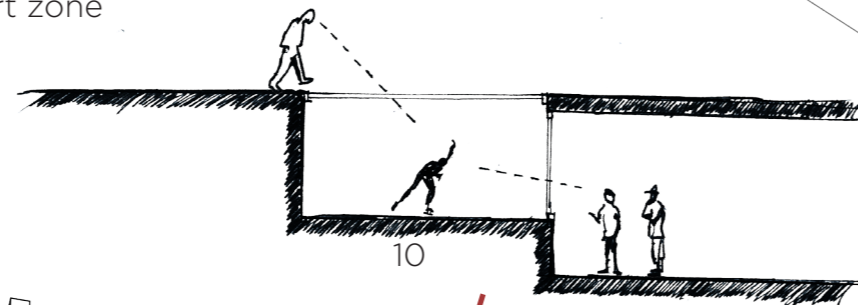
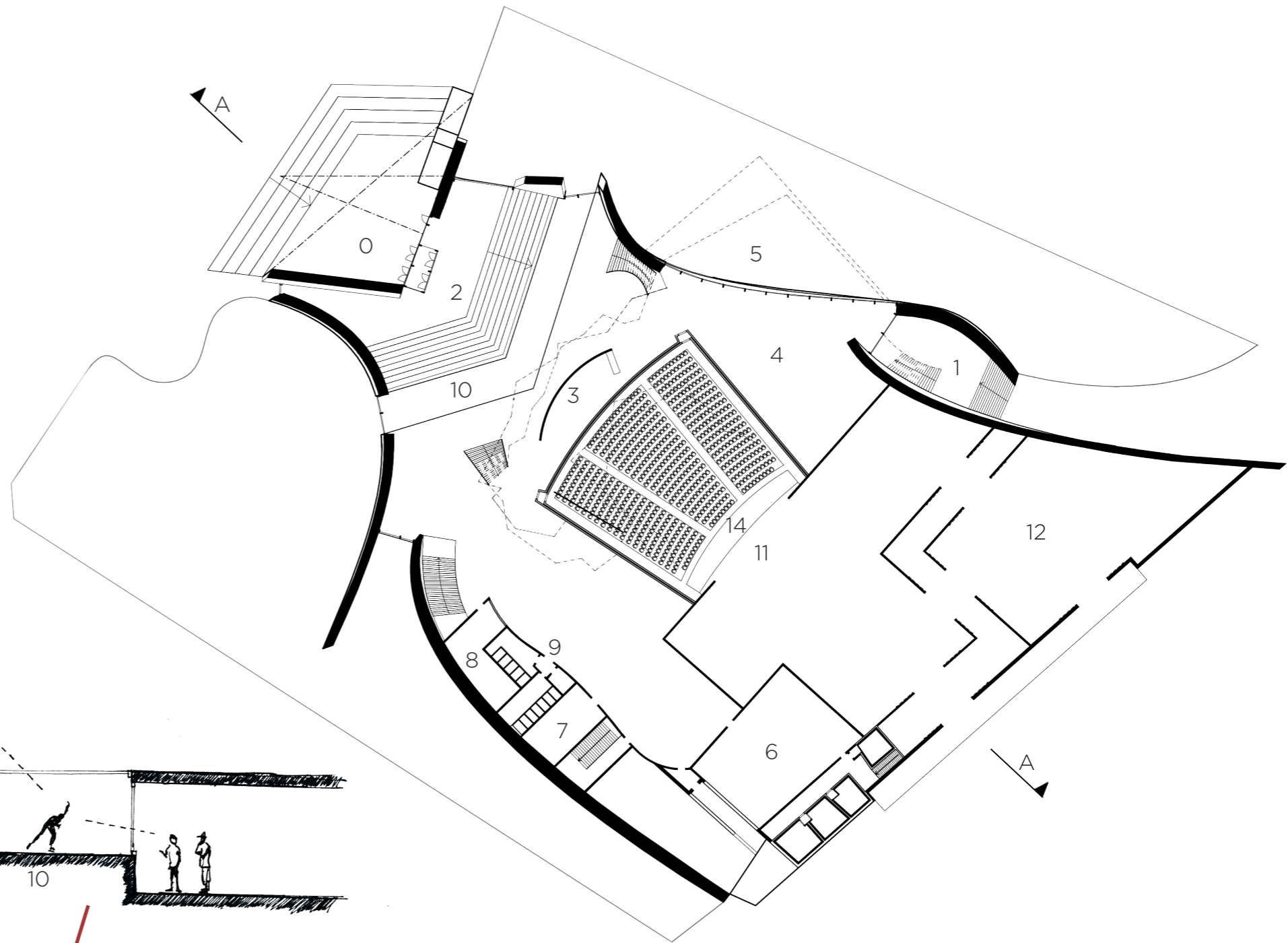

Sektion A-A

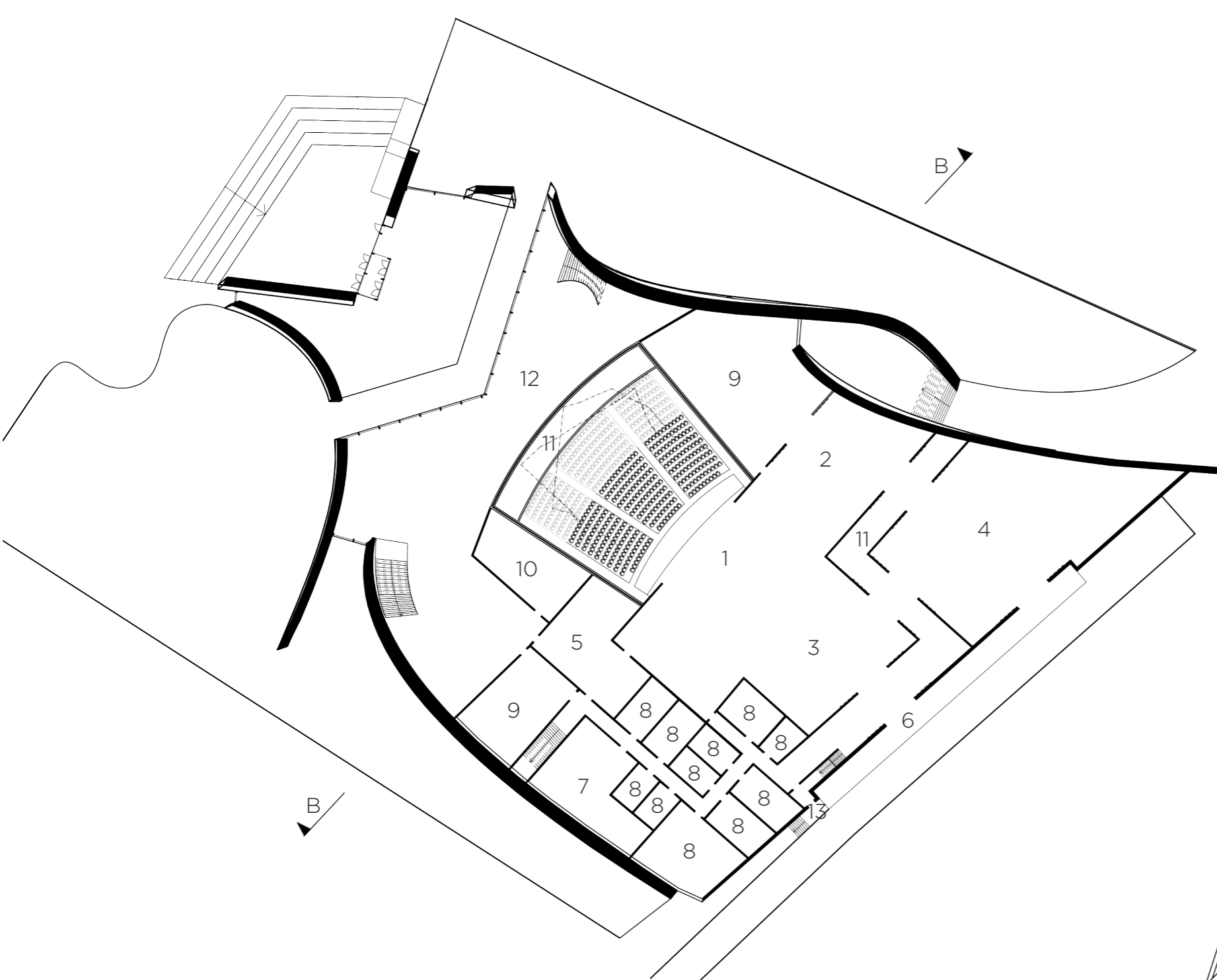

PLAN -1

1:500

- 1 Scene
- 2 Side stage
- 3 Backstage
- 4 Scene shop
- 5 Green room
- 6 Loading dock
- 7 Wig/Costume shop
- 8 Dressing room
- 9 Storage
- 10 Manager office / Personal
- 11 Mechanical equipment room
- 12 Exhibition area
- 13 Staff entrance

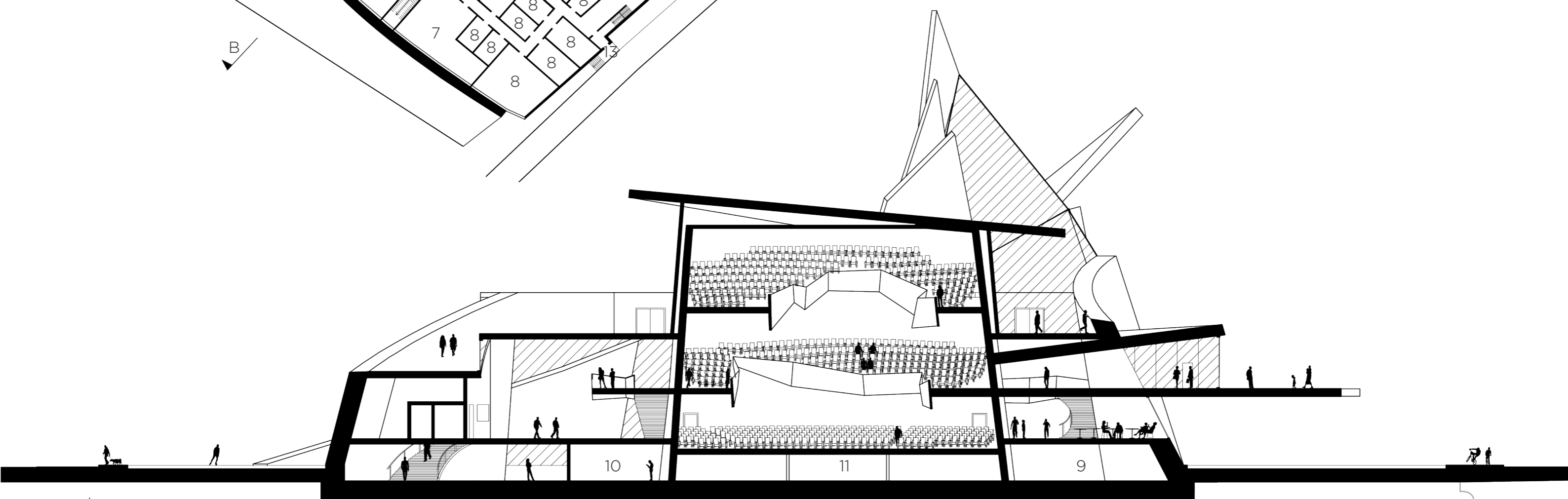

Sektion B-B

OVERVIEW

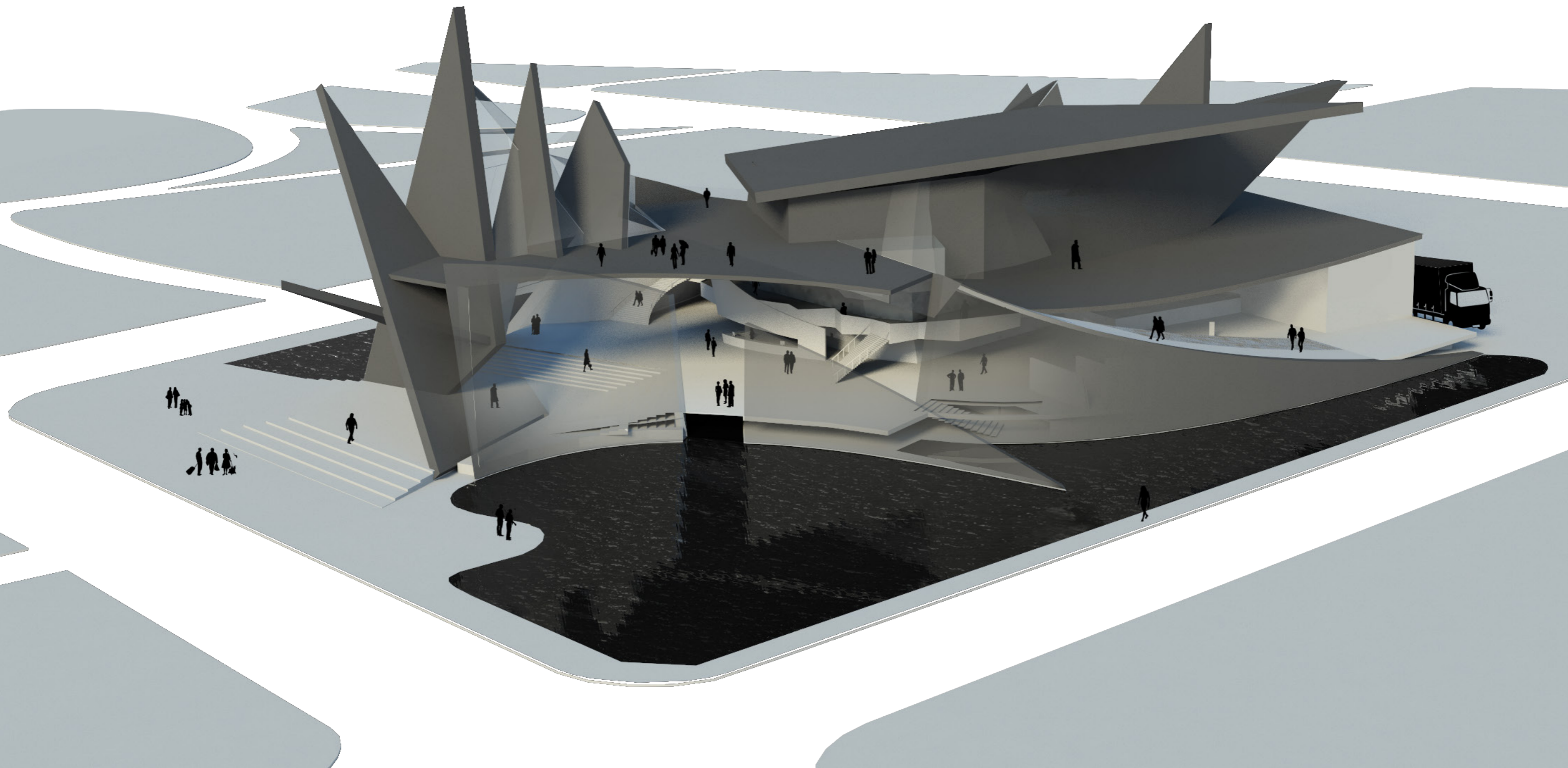

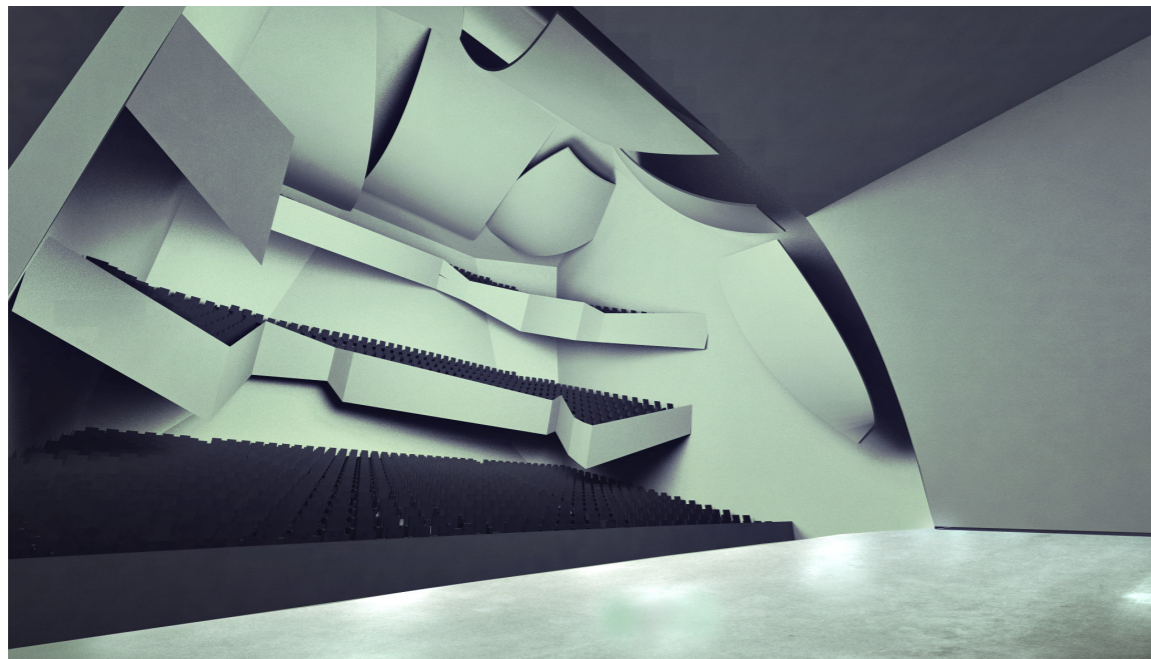

OPERA AND THEATRE

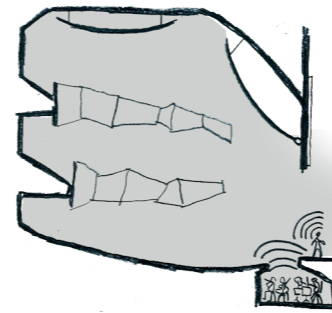

CONCERT AND MUSIC

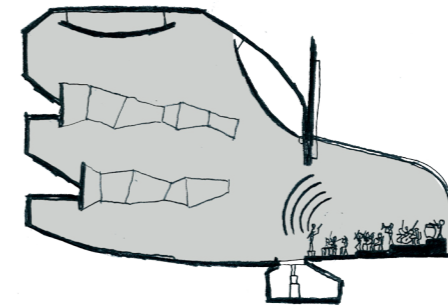

SMALLER EVENT

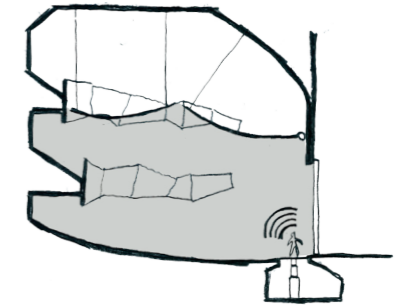

ACUSTICS

Fully crowded the performance hall offers a reverberation time of 1.5 s and clarity in the -2 dB range, suitable for music and opera performances. . The sidewalls and balconies are shaped to provide the early reflection pattern necessary to induce a strong sense of envelopment. Variable acoustics allow the reverberation time to be lowered and the clarity to be increased, without compromising the warmth of the sound.

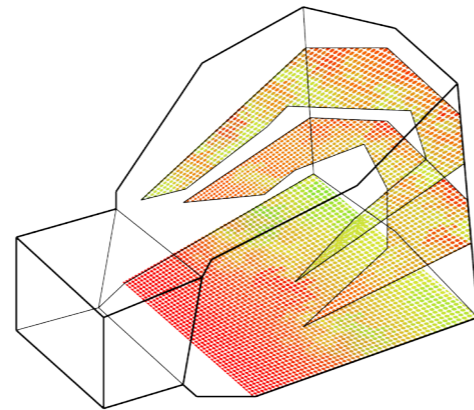
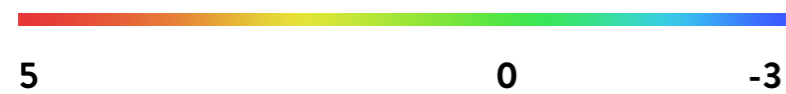

Sound pressure levels are evenly distributed throughout the auditorium, the strength ranges in the 3-5 dB region.

CLARITY - C80

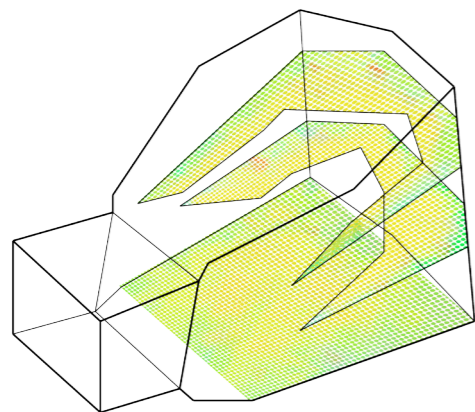
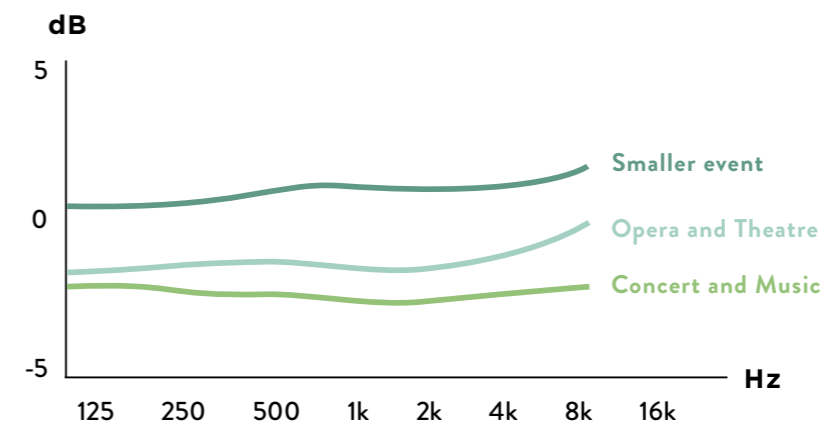

The reverberation time shows only minor deviations vouching for a good balance in material properties and balcony dimensions. Reverberation time (T30) around 1,5 s

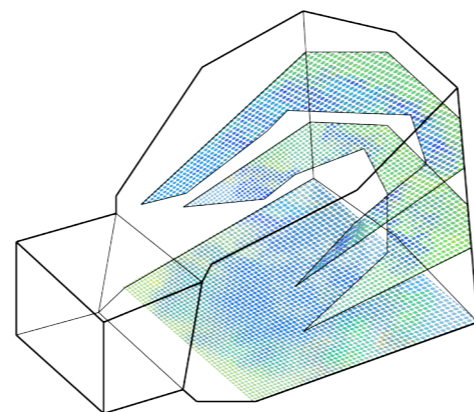

A consistent clarity (C80) throughout the auditorium means suitable weighting in surface properties as far as balance between early reflections, scattering and absorption.

REVERBERATION - T30

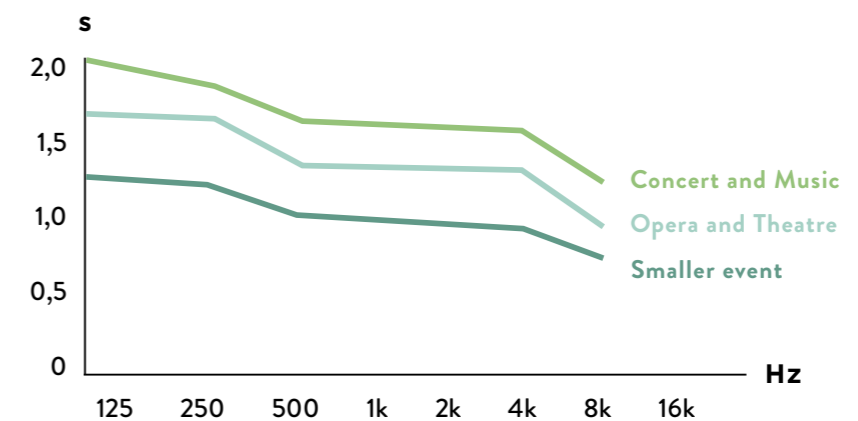



AUDITORIUM

Entering the performance hall the whole volume shimmers in the light shining through perforated Butong, forming the balcony fronts and wall sections. Wooden panels on the side walls bring warmth to the room and offer a tasteful contrast to the ridged stone partitions and the bright ceiling reflectors.

The entire auditorium is designed as an isolated inner shell to terminate noise from the lobby as well as structure borne vibrations from the roof and outer balconies. A double door sound lock system with highly absorptive walls and ceiling allows visitors and personnel to move in and out during performances.

The balcony fronts consist of Butong, a perforated concrete with a warm, shimmering glow when lit from behind. By controlling the size and depth of the perforations the Butong panels can form both broadband diffusers and low end absorbers.

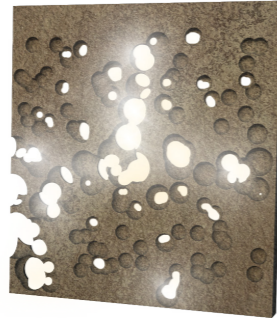

Reflective side walls

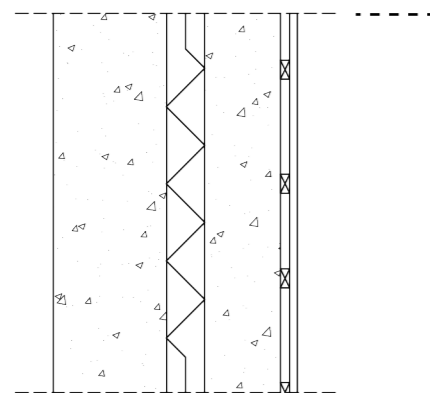

- 300mm structural concrete
- 100mm polystyrene insulation
- 200mm concrete surface panels
- STC 79

ADJUSTABLE ACOUSTICS

As the performance hall is designed to host events of different nature, the acoustic properties must be changed accordingly. For a grand performance the auditorium seats 1200 persons with acoustics well suited for opera or concerts.

The movable stage shell makes a good choice for musical performances producing a slightly increased reverberation time as the absorptive stage tower is sealed off.

For smaller events the reverberation time is reduced by lowering the ceiling reflectors, effectively sealing the acoustical volume at the second balcony.

Raising the orchestra pit provides a small stage as the proscenium is sealed off by sliding doors. This setup still provides the 720 seats on the main floor and an additional 250 seats on the lower balcony.

PERFORMANCE HALL DETAILS

The entire auditorium is designed as an isolated inner shell to terminate noise from the lobby as well as structure borne vibrations from the roof and outer balconies.

Absorptive rear wall

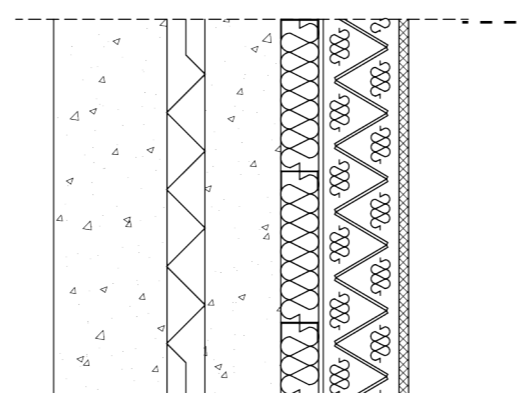

- 300mm structural concrete
- 100mm polystyrene insulation
- 200mm concrete inner shell
- 100mm batt insulation
- 13mm pressed fibreglass
- 200mm folded pressed fibreglass sheets
- 25mm quilt batting
- cloth surface
- STC 91

ACCESS & ACTIVITIES

As a visitor of the opera you are offered a number of activities and rooms to explore. Access, openings and views are orientated towards the eastern site where the water lies as a mirror in front of the opera and the green park on the opposite side.

Café

A relaxing area with view over the water and Montreals skyline. Offers both indoor and outdoor seating. On the second floor of the café you have the VIP lounge.

Water and Ice Skating

Water surrounds the building on both sides and is connected through a passage underneath the foyer which is visible from both the foyer and the exhibition area. During winter the water pools freezes and functions as a ice saking rink. People can then ice skate between both sides.

Roof

Visitors of the opera can reach the roof terrace from several places and enjoy a magnificent view over the city and at the same time getting some fresh air during breaks between acts.

Exhibition

The exhibition area on the bottom floor is reached from both sides of the foyer. It's in direct contact with the ice passage and is lit up by skylight penetrating all the way from the roof of the foyer.

Wall Details

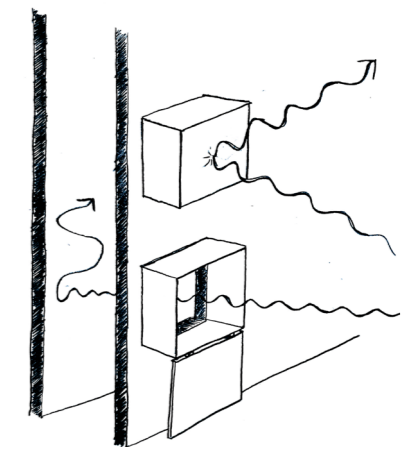
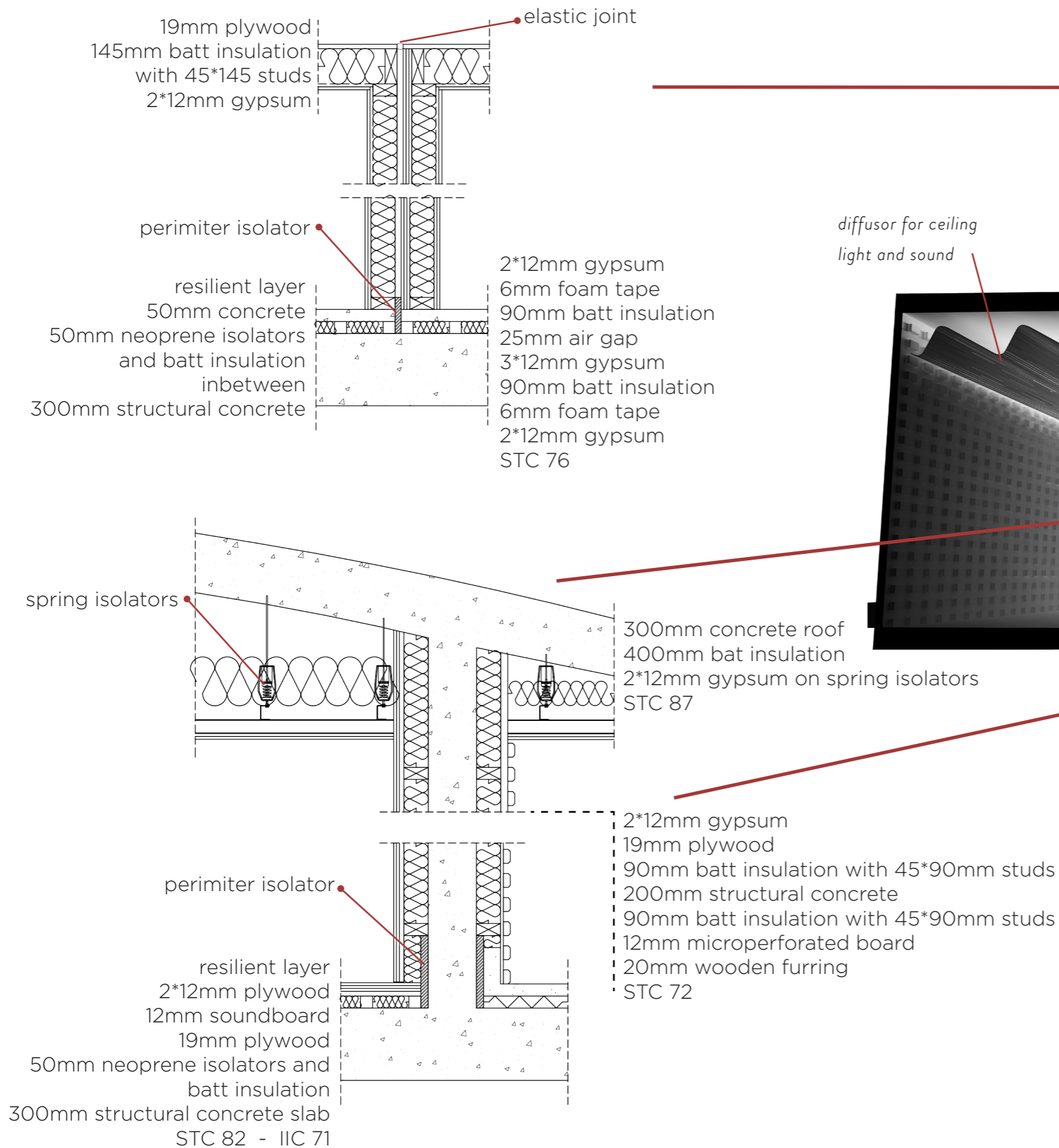

diffuser for ceiling light and sound

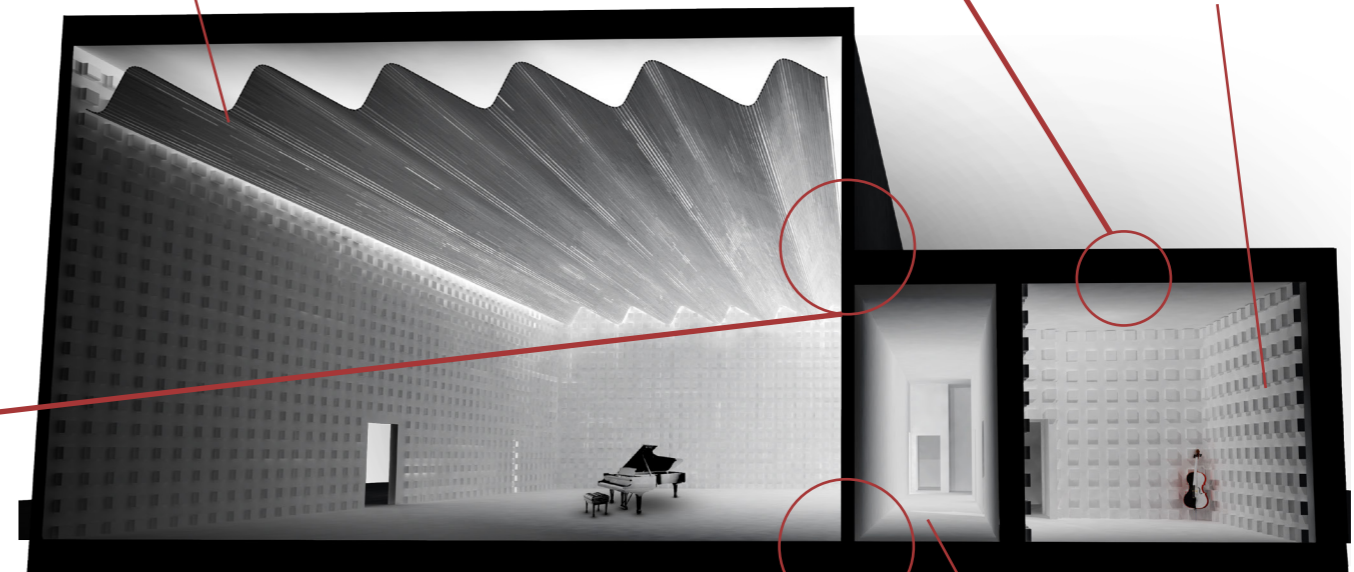

Practice rooms

Acoustically separated solo rooms allow multiple artists to rehearse simultaneously. Practice is possible even when there is an ongoing event in the main rehearsal room. The highly absorptive separating corridor provides both sufficient attenuation as well as possibilities to move around without disturbance.

Preparations with an electronic feedback system render the possibility to convolute a singers voice with the impulse response from any given hall, thus giving the artists a chance to practice in an artificial soundscape.

REHEARSAL ROOMS

Rehearsal room

The rehearsal room is a multi purpose room located in the foyer which functions as both a rehearsal room for music and dance as well as an extra stage for smaller performances.

The curvy ceiling made from striped red western cedar acts not only as an esthetically beautiful detail but also as a diffuser for the hidden lighting as well as the sound from the stage. The nonparallel walls are covered with additional diffusers to ensure a soundscape free from coloration and echoes.

Adjustable walls

Heavy drapery lowered from above the ceiling enables easy accessible alterations of the acoustical settings depending on the crowd and current event.

SITE AND NOISE

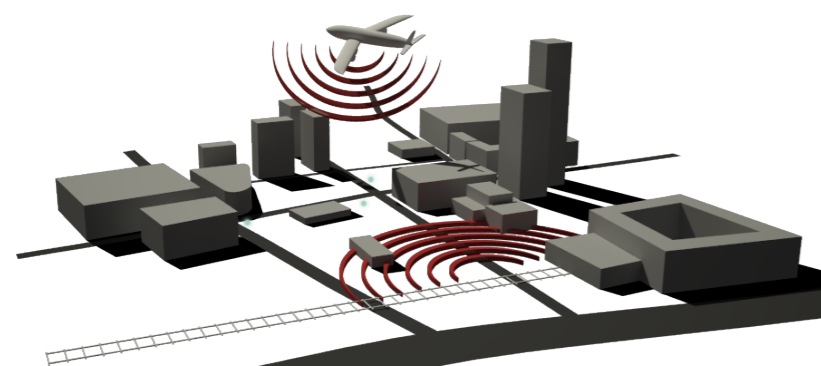

Opera site is exposed to noise from near traffic, trains on the railway, and air traffic.

PROCESS

The process consisted of several iterations where we started to build multiple small concept models of cardboard and had discussions in small groups during a seminar criticism. We then selected the concept we liked best and made more, and more detailed models in bigger scales. In the project's initial phase, we also had some experimental acoustic exercises and lectures with our acoustics professor Mendel to get an overview of the subject.



conceptmodel made of cardboard. 1st iteration



2nd iteration

FORM CONCEPT

The conceptual idea is inspired by the shape and natural beauty of broken ice shards. This idea was taken into reality by picking out the shards created from an impact to a block of ice and then bent and rotated in different ways to form the walls, windows and roof of the building. The shapes does not only inspire the exterior of the opera but also the balcony fronts in the auditorium and in the foayer.



inspiration - painting by Caspar David Friedrich



Blocks of ice break loose and floats apart under the spring sunrays.

Foayer

