

# CHALMERS



## Design of an ergonomic control lever for wheel loader attachments

Master of Science Thesis [*in the Master Degree Program Industrial Design Engineering*]

SARA ALPSTEN

HENRIK EKLUND

Department of Product and Production Development  
*Division of Design and Human Factors*  
CHALMERS UNIVERSITY OF TECHNOLOGY  
Gothenburg, Sweden, 2012

Design of an ergonomic control lever for wheel loader attachments.  
Sara Alpsten & Henrik Eklund  
© Sara Alpsten & Henrik Eklund, 2012  
Department of Product and Production Development  
Chalmers University and Technology  
Gothenburg, Sweden, 2012

# Acknowledgements

This thesis work has taken an extensive part of our lives during the autumn of 2011 and the spring of 2012. So first of all, we thank our closest family members for supporting us and making this possible - thank you all.

During this work, we have learned a great deal in planning and executing product development projects. But, the project would not have been as giving if we had not met and got help from people around us. Following persons has made this thesis work richer and we are thankful for their help.

We would like to thank Andy Wijkö, Project manager at CPAC System, for inviting us and giving us this opportunity and also for his supervision during our thesis work.

We are thankful for the input regarding ergonomic analyses from Paul Piamonte, Human Factors & Ergonomics Specialist at Volvo Group Trucks Technology.

We thank Lars-Ola Bligård, Project Assistant at Design & Human Factors, Chalmers University and Technology, for his supervision and constructive input to the academic aspect of the thesis.

We thank the reference group and participants at Volvo Construction Equipment for taking their time during the concept evaluations and for all valuable input that they have given us.

We thank Swecon in Mölndal, Volvo Construction Equipment's reseller, which has helped us and especially Lars Wiberg, salesman at Swecon, for his valuable input and contact references to entrepreneurs.

A special thanks is send to the machine operators who have given us opportunity for observation and analyzing the work situation; Vikans Kross in Gothenburg; Per E Person Transport AB in Borås; Stig Gustavsson Maskin AB in Borås and Niclas Entreprenad AB in Gothenburg.

Thank you

Sara Alpsten & Henrik Eklund





# Abstract

Wheel loaders are working machines used in excavation, load and carry operations in many different professional fields. In construction equipment machines, the movement towards electrically controlled hydraulic functions has raised ergonomic benefits. Larger possibilities of position adjustments of control units and larger degree of freedom in the design and form of the controls are now available. The full potential is however not fully put to use for the freedom of ergonomically design the control levers. Some world markets also ask for optional control levers for controlling attachments, such as buckets and snowplows, beside the traditionally used linear levers for etc.

This thesis work purpose is to design an ergonomically optimized single lever concept, which is indented to be used to maneuver these hydraulically empowered attachments. It is part of an on-going pre-study assigned to CPAC System AB regarding a single lever for wheel loaders.

Needs and design heuristics were synthesized from theoretical research and ergonomic analysis that revealed issues present in the work situation. Several concept development iterations were made using the design heuristics as starting-point and elaborating the needs. Physical prototypes, such as mock-ups and finally a functional prototype that were tested in a real wheel loader, were used for evaluating the fulfillments of these needs.

The outcome from the project is a single lever concept adapted for wheel loader usage and designed for fast implementation in current products.

*Keywords: physical ergonomics, cognitive ergonomics, wheel loader, machine operator, single lever, joystick.*



# Content

<b>1 Introduction .....</b>	<b>9</b>
1.1 Project background .....	9
1.2 Purpose and Goal .....	10
1.3 Question formulation .....	11
1.4 Delimitations .....	11
1.5 Report outline .....	12
<b>2 Current situation .....</b>	<b>13</b>
2.1 Product functionality .....	13
2.2 Single lever screening .....	18
<b>3 Theory .....</b>	<b>21</b>
3.1 Physical ergonomics .....	21
3.2 Cognitive ergonomics .....	27
3.3 Standards and recommendations .....	29
<b>4 Methods .....</b>	<b>31</b>
4.1 Data collecting methods .....	31
4.2 Analysis methods .....	32
4.3 Idea generation methods .....	34
4.4 Concept evaluating methods .....	35
<b>5 Project implementation .....</b>	<b>37</b>
5.1 Description of procedure .....	37
<b>6 Analysis .....</b>	<b>41</b>
6.1 Human-machine system description .....	41
6.2 Wheel loader operators and task .....	43
6.3 Physical ergonomics in wheel loaders .....	53
6.4 Cognitive ergonomics in wheel loaders .....	58
<b>7 Problem definition .....</b>	<b>67</b>
7.1 Conclusion from theory and analysis .....	67
7.2 Summary of needs .....	68
7.3 Design Heuristics .....	71
<b>8 Concept generation 1 .....</b>	<b>73</b>
8.1 Idea generation .....	73
8.2 Concepts .....	76
8.3 Concept selection .....	78
<b>9 Concept generation 2 .....</b>	<b>81</b>
9.1 Idea generation .....	81
9.2 Concepts .....	84
9.3 Concept selection .....	86
<b>10 Concept generation 3 .....</b>	<b>87</b>
10.1 Elaboration of needs from chapter 7.2 .....	87
10.2 Creation of functional prototype .....	90
10.3 Detailed concept description .....	92

<b>11</b>	<b>Concept evaluation</b>	<b>97</b>
11.1	Execution of the evaluation	97
11.2	Results	99
11.3	Conclusion of the evaluation	107
<b>12</b>	<b>Final concept</b>	<b>109</b>
12.1	Elaborated needs from chapter 10.1	109
12.2	Redesign of prototype	112
12.3	Detailed concept description	116
12.4	Concept validation with reference group	120
12.5	Final remarks on the concept	121
<b>13</b>	<b>Discussion</b>	<b>123</b>
13.1	Goal fulfillment of the final concept	123
13.2	Feasibility of concept	124
13.3	Work process and procedure	124
13.4	Specific topics of interest	126
13.5	We have learnt	127
<b>14</b>	<b>Conclusion</b>	<b>129</b>
	<b>References</b>	<b>131</b>
	<b>Appendix I - VIII</b>	<b>I-XXIV</b>

# 1 Introduction

*The underlying reason for initiating the thesis work and project is presented together with the scope of the project - purpose, goals, question formulation and delimitations. The technical background gives a short explanation about wheel loader hydraulics and connects the work environment with ergonomic issues stated in literature. The last part of this chapter gives the reader an overview of the content of this report.*

## 1.1 Project background

Volvo Construction Equipment (Later Volvo CE), a subsidiary of Volvo AB, is one of the world's largest manufacturers of construction machines. In the construction industry, performance, robustness and reliability are the most relevant qualities and selling points. Yet the market demands even higher operator comfort – and comfort is a highly prioritized characteristic within the Volvo brand. In Volvo CE's latest wheel loaders series (the "G-series", *figure 1.1*) the servo-assisted control levers have been replaced with electrically maneuvered control levers. The introduction of electrically maneuvered levers opens up, from a product development perspective, new possibilities of how the levers can be designed. This makes it possible to satisfy the increasing market demand of controlling the machine using a single lever, instead of the current four levers.

CPAC System AB (Later on shortly named "CPAC") develops and integrates safety critical control systems for vehicles operating in tough environments, such as industrial vehicles. CPAC were given the assignment of performing a pre-study of a single lever concept. As a part of the pre-study, this master thesis constitutes an analysis of how the design of the single lever can be ergonomically optimized to achieve a high operator comfort in the cabin (*figure 1.2*).

This is the rationale behind this research work and development of a prototype of a single lever control for wheel loaders. The thesis work results in this report over the project work.



*Figure 1.1 Volvo Wheel Loader (Volvo CE, 2011 a)*

### 1.1.1 Technical background

Hydraulics is the system that produces the force and movement of an attachment, e.g. a bucket. Basic functions are *lift* and *tilt*, and, in many cases, one or two additional functions are made available. The operator uses the control levers placed on the right side of the driver's seat (*figure 1.2*), to control the hydraulics. The control unit currently in use includes two to four linear levers (*figure 1.3*). Previous research related to the control levers' design has not included deeper ergonomic studies or methodology and the market demand other solutions than now available. The work environment is tough on the body and the operator performs repetitive work movements and at the same time is exposed to static working postures (Nilsson & Rose, 2003, p. 9). Statistic research and medical research have revealed relationships with occupational injuries and the work in off-road machines. Musculoskeletal disorders seem to arise from long working sessions, static and/or awkward working postures in combination with inappropriate control levers or placements of control levers, according to Adolfsson, Öberg and Torén (2002 p. 7).



*Figure.1.2 Cab interior (Volvo CE, 2011 a)*



*Figure.1.3 Control levers (Volvo CE, 2011 a)*

## 1.2 Purpose and Goal

The master thesis' purpose is to design an ergonomically optimized single lever concept that fulfills the market demands. The project therefore contains work that is research on this problem area, and development of a conceptual design to solve that. This means that the result is not intended to be a definite part of any company's product plans. It is a prerogative of the product developer to decide whether this work may contribute to a concrete product development plan. Two to four main hydraulic functions are to be integrated into one single lever. Any additional function needed, must be designed for in the final overall solution. The work environment for a wheel loader operator will be investigated, and guidelines for improved physical- and cognitive ergonomics will be presented. The final solution is a physical prototype with highest functional capability as possible, as basis for further construction development. The final concept shall:

- Be as original as possible and not be a conscious replication of existing products.
- Be designed for wheel loader environment.
- Improve the physical ergonomic conditions for the machine operator.
- Improve the learning curve for novice users.
- Meet the market's demands.

## 1.3 Question formulation

The studies and analysis are aimed to answer to a set of questions in order to also improve the situation. These are defined and centered on the user to understand the user's needs. The questions are:

- Who is the user?
- What is the task?
- How is the user affected by the task?
- What are the physical and cognitive ergonomic needs?
- How can these ergonomically needs be fulfilled?

## 1.4 Delimitations

As any project, this thesis work is delimited to be feasible and manageable. Also, the stakeholders of the project, CPAC and Volvo CE, have requirements on the thesis work to be coherent with their strategy objectives. The delimitations for the thesis work and project output are defined as:

- The physical ergonomic load from the control lever/single lever will be related to the armrest and the transition between the armrest and the control lever unit. However, the armrest's issues lay outside of this project's scoop. Suggestions for design changes for the armrest might be given but will not be included in the final design.
- The final concept will keep the current interface between the control lever unit and the armrest using the same metal bracket.
- It is important that the final concept is technically feasible consisting of existing components, to shorten the implementation time if an implementation of the final concept would be in question.
- The final concept should have the same functionality as the current control lever unit.
- The interface to the electro-hydraulic system is not to be compromised although software changes are possible to some extent.
- Volvo sells their wheel loaders on a global market, which makes the whole world population possible primary users. To narrow it down, interviews, observations and evaluations have only been performed with Swedish machine operators.

## 1.5 Report outline

Chapter 1- Introduction: This chapter gives the background and scope of the project. A report outline also gives an overview of the content of this report.

Chapter 2 - Current situation: Wheel loaders, control levers and joysticks are described in this chapter. How and where these artifacts are used, together with common attachments, are examined to get a deeper understanding of the product functionality.

Chapter 3 – Theory: The chapter gathers human’s physical and ergonomic limitations, described hand anatomy and cognitive terms that all are later used in the report. A theoretical derivation encircles ergonomic issues that motivates why there is a need to develop a new product. Finally, recommendations related to hand levers are summarized.

Chapter 4 – Methods: All methods used in the project are shortly described here, while their executions are described later in the chapters where used. Methods for analysis, idea generation, evaluation (some unique for this project) and data-collection are described.

Chapter 5 - Project Implementation: This chapter gives the reader an overview of different phases in the project and how the project was executed. The procedure of the project is described with a graphical model. Explanations of the phases clarify what activities were done and why they were done.

Chapter 6 – Analysis: The reader is here given thorough descriptions of method executions, the results and the conclusions of used methods. The human-machine system is analyzed for both physical and cognitive ergonomics issues. The chapter also describes the users, and also tasks that must be performed by the future product.

Chapter 7 – Problem definition: This chapter synthesizes previous chapters and defines what needs the product must fulfill and gives a hint of how to fulfill them. First; a conclusion of the problem is described, second; a set of needs from different aspects is tabled and third; a set of design heuristics is presented.

Chapter 8 – Concept generation 1: Ideas and concept that came out of the first iteration is described with the selection of concept to further develop in the second iteration.

Chapter 9– Concept generation 2: This is the description of the second iteration and the reader will see the same structure of this chapter as the previous. Three concepts are constructed from the one selected from the first iteration.

Chapter 10 – Concept generation 3: A functional prototype is the outcome in the third iteration. The chapter gives details of the concept and a set of specification shows how to fulfill the needs stated in chapter 7.

Chapter 11 – Concept evaluation: The functional prototype is evaluated and the execution, results and at the end of the chapter, conclusive design changes are described.

Chapter 12 – Final concept: A new prototype is constructed by the input from the concept evaluation in this chapter. The reader will see the work procedure and refined specification of the concept. At the end, the design changes recommended from the concept evaluation are validated.

Chapter 13 – Discussion: Here the reader can find out the project members’ own view on parts of the work. Topics of the result, certain decisions made, method used and project implementations are discussed.

Chapter 14 – Conclusion: The final chapter of the report concludes the project and the report. This chapter state fulfillment of project goals and personal goals.



# 2 Current situation

To get a deeper understanding of the context for the project, the product functionality is identified in this chapter in terms of how and where wheel loaders are used and what functionality the control lever unit has. Also, a screening of single levers defines the term joystick and an image board of existing single lever can be seen at the end of the chapter.

## 2.1 Product functionality

The future product must, as stated in the goals, consist of existing products and have the same functionality as the current product. The control levers' function is to maneuver different attachments, that is, different devices or tools attached to the wheel loader. Different use scenarios put different requirements on the product. As for now, the technique for this maneuvering has been two or more levers working in a linear motion. The control of the machines hydraulic system has been to mechanically effect valves to regulate the oil flow, assisted by oil-hydraulic servos. These servo-assisted levers have because of this technology, been stationary inside the cabin. More modern technologies have developed the levers to electrically effect valves by wires. So, electro-hydraulic controls have more flexible mounting. Today this does not exist in any Volvo CE model.

### 2.1.1 Different attachments and usage situations

Wheel loaders are working machines used in load and carry operations, civil & building construction, timber yards, agriculture, material handling, waste handling, snowplowing and more (figure 2.1). The machines have replaced hand tools such as spades and pickaxes etc. but are today able to have many different devices attached. These attachments can be specialized for a specific purpose, or for more general use.



Figure 2.1. Different work situations (Volvo CE, 2011 a-e)

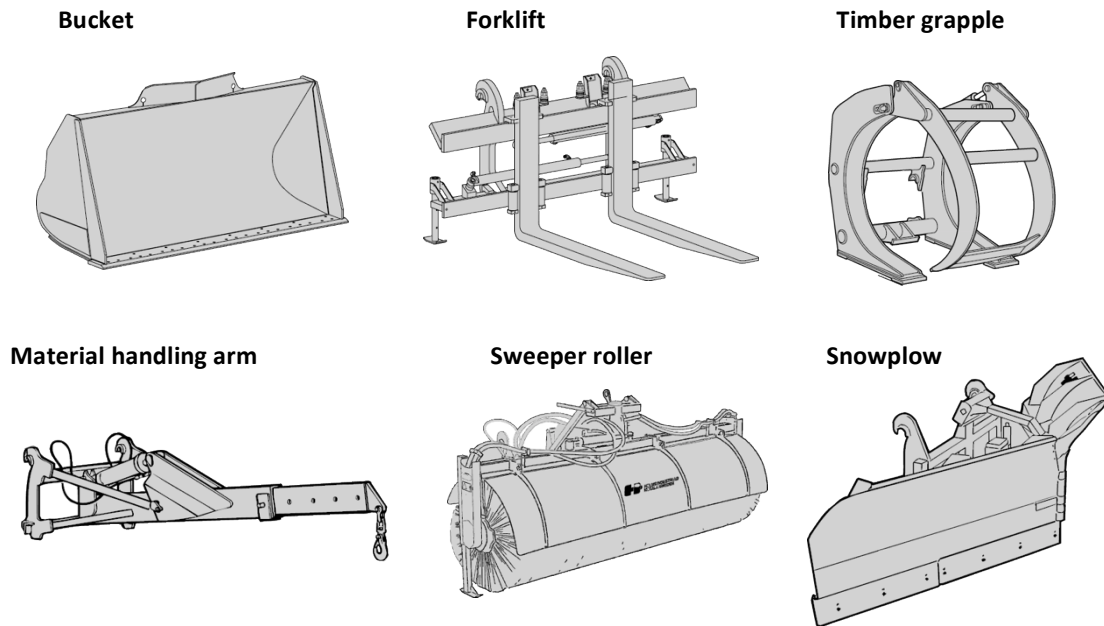

Figure 2.2 Different attachments (*Wheel loader attachments, 2011*)

Perhaps the archetypical attachment is the bucket used for excavating gravel, rocks, sand and other matter. The most common attachments are buckets, forklifts and timber grips, but wheel loaders can also be attached with material handling arms, sweeper rollers and snowplows (*figure 2.2*). Buckets are often used in load and carry operations, fork lifts in civil & building construction, timber grapples in timber yards, material handling arms in material handling, sweeper rollers in waste handling and snowplow blades for snowplowing.

### 2.1.2 Control lever functionality

The electro-hydraulic control levers, which are used as standard equipment in the G-series, consist of two to four linear levers together with surrounding buttons. Machines equipped with a regular bucket use only two linear control levers. Machines where other attachment is used need three to four linear control levers. Each lever is moved in a single forward/backwards movement, i.e. called linear levers. Small movements from the neutral position opens an oil valve to a small extend, resulting in a slow movement of the attachment. The valve solely regulates the oil flow and with that the speed and force of the hydraulically maneuvered arms. In addition, there are a number of other functions on the control lever unit such as buttons and rocker switches (*figure 2.3*) (*table 2.1*).

*Signal horn* (5) is used to warn or communicate with co-users and side users. It is also necessary to have because of safety regulations. *Kick-down* (6) is used to gear down to the first gear, which e.g. is necessary when entering a gravel heap. *Kick-down* is frequently used when operating the machine. The *Engine break/Gear down* (7) button is multifunctional. One push on the button will gear down a gear and if the button is held down, the engine break is activated. *Gear down* is used frequently when operating the machine and can be used instead of *Kick-down*. *Engine break* function is mostly used in transport. This multifunctional button will hereafter be named *Engine break*. *Direction selector* (8) is used to select drive direction; forward, backwards or kept in neutral, but first the function must be activated by pressing the *Activation direction selector* button (9).

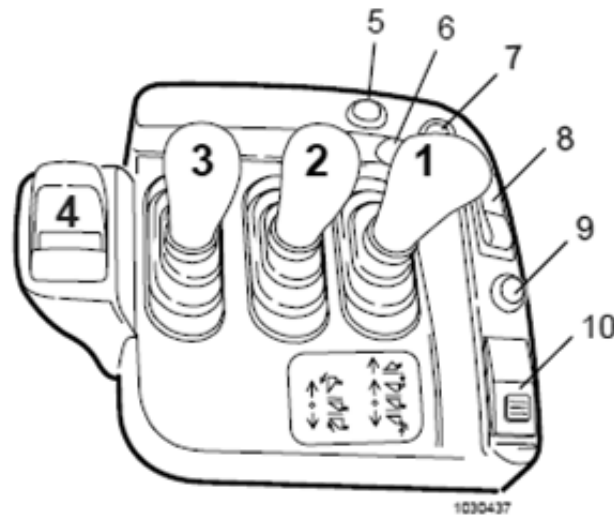

Figure.2.3. Control lever unit with four levers (Volvo CE customer support, 2011)

Table.2.1 Explanation of controls seen in fig.2.3.

Number	Function	Type of control
1	Lift	Lever
2	Tilt	Lever
3	3 <sup>rd</sup> function	Lever
4	4 <sup>th</sup> function	Lever
5	Signal horn	Button
6	Kick-down	Button
7	Engine break/ Gear down	Button
8	Direction selector	Rocker switch
9	Activate Direction selector	Button
10	Lock control	Rocker switch

*Direction selector* is frequently used when operating the machine but whether or not the direction selector on the control lever unit is used depends on the machine setup. *Direction selector* can be controlled either by the rocker switch on the control lever unit, or by a lever behind the steering wheel or by a rocker switch placed on the Comfort Drive Control (CDC).

The CDC is placed on the armrest on the left side of the chair (figure 1.2). A machine operator using CDC will probably not use *Direction selector* on the control lever unit, however are only 5% of the machines (on a global market) are equipped with CDC. *Lock control* (10) is only used in transport. The function disables electronic signals from the levers so the bucket (or other attachment) does not respond to any lever movement - so the bucket do not accidentally move when e.g. transporting the machine on a public road.

*Lift* is used to lift and lower the bucket and *tilt* lever is used to tilt rearward and tilt forward the bucket (*figure 2.4*). In addition to the proportional *lift* and *tilt* there is a mechanical hold function at the end position of the levers. *Lift* has two hold functions – one in each end position of the lever – and *tilt* has one hold function at the end position of tilt in. The hold function for *tilt in* automatically tilts the bucket to the neutral plane. The bucket position for how high and how low the bucket will be lifted or lowered when using the hold functions can be predefined by the operator.

The usage of the 3<sup>rd</sup> and 4<sup>th</sup> *function* depends on what attachment that is used. On a pallet fork the 3<sup>rd</sup> *function* is to set the distance between the forks and the 4<sup>th</sup> *function* is to adjust both forks sideways (*figure 2.5*). The 3<sup>rd</sup> *function* on a timber grapple is used to open and close the grapple. Some grapples also have a 4<sup>th</sup> *function* consisting of two extra grapples that is used to push out any remaining logs (*figure 2.6*). A snowplow can have one or two blades. If having one blade the 3<sup>rd</sup> *function* controls the angle of the blade. If having two blades the 3<sup>rd</sup> *function* controls the angle of the blade on the right side and the 4<sup>th</sup> *function* controls the angle of the blade on the left side (*figure 2.7*).

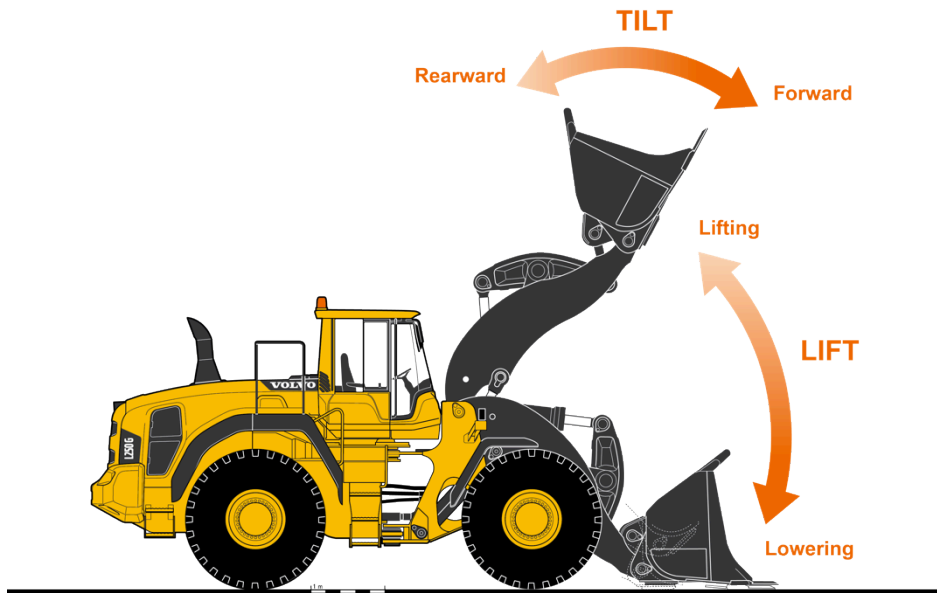

Figure 2.4. Lifting and tilting the bucket (Volvo CE, 2011 e)

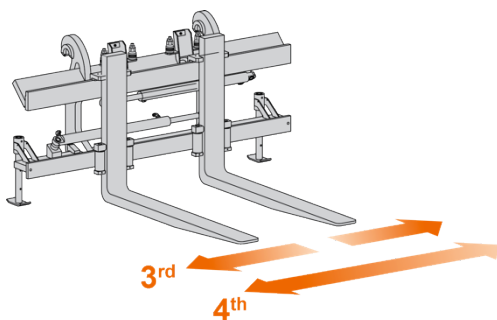

Figure 2.5. 3<sup>rd</sup> and 4<sup>th</sup> function on a Pallet fork Wheel loader attachments (2011)

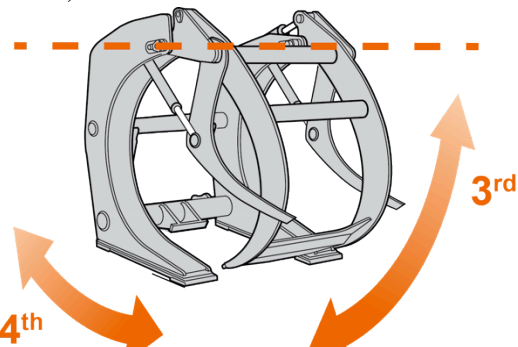

Figure 2.6. 3<sup>rd</sup> and 4<sup>th</sup> function on a Timber grapple Wheel loader attachments (2011)

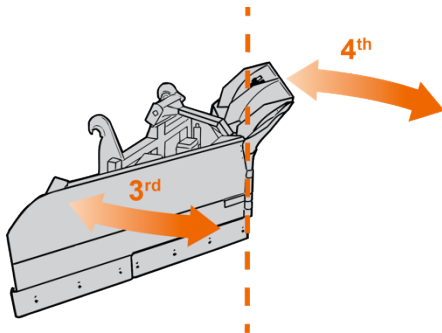

Figure 2.7. 3<sup>rd</sup> and 4<sup>th</sup> function on a Snowplow Wheel loader attachments (2011)

## 2.2 Single lever screening

Levers that are used for more than one function are available in many applications today, but cannot be regarded common in wheel loaders. A small research is done in similar vehicles such as tractors and forestry machines etc. that have somewhat similar work conditions for the operator, although none have been manifested exactly the same conditions.

### 2.2.1 Joystick definitions

Joysticks are maneuvered both in forward/backward movements, and also sideways, so this kind of levers has two axes, to control two functions simultaneously. A few definitions of different joysticks are described by Adolfsson et al (2004); *mini-joysticks* are also called *finger-hand levers*, meaning the joystick is small enough to be operated only by the hand and finger, left lever (*figure 2.8*). *Hand-arm joysticks* are joysticks or levers that are bigger, that requires not only the hand, but also the arm itself to move in order to be operated, right image (*figure 2.8*).

#### Mini-joystick

Small joysticks and mini-levers, such as mini-joysticks are used with a pen-holding grip and precision-movements are given by finger- and hand-muscles (*chapter 3.1.2*). This type can enable relief of the arm's weight by armrests and also give possibilities to variation of hand positions Mini-levers cause the wrist to work in extended position, the forearm in pronated position and joints are used statically (Adolfsson, et al, 2004).

#### Joystick

Also called “Banana-joystick”, this type differs from the previous joystick foremost by the size of it. Users utilize a power grip with this lever. When used for precision adjustments, also elbow and/or back shoulder muscles must be activated. Index fingers MCP-joint and wrist is used in expanded position. This joystick is regarded unsuitable on bigger wheel loaders due to sensibility from outer factors such as shocks Adolfsson et al (2004 p.15)



Figure 2.8 Mini-joystick (left) and joystick (right)

## 2.2.2 Technical terms related to joysticks

The terms used in the report also regards *joystick bases* and *sensors*. These are the name for the integrated units of mechanical joints and electrical boards. The lever handles users grip when maneuvering the levers are mounted to the joystick base. Sensor use the same electrical technology, but is smaller and only for one direction and function. Different types of switches or wheels can be mounted on sensors.

All these technical solutions are also termed *proportional*. This means that greater movements result in a more intensified electrical signal from the sensor or base. This is the opposite of *binary* sensors that would only give signal or not give signal.

## 2.2.3 Use of single levers today

As for now, Volvo CE does not have any electro-hydraulic single lever for their wheel loaders. To get inspiration and see joysticks used in other machines an image board was assembled (*figure 2.9*). There are some models with a servo-assisted single lever of standard size, similar to the joystick in *figure 2.8*. Although, the stationary position and older technique imply that this is not an alternative for this project to study any further.





Figure 2.9 Image board Single levers

The three upper images are thumb-controlled joystick. The two to the left is located in a Ålö front loader and the one to the right is located in a Ponsse forestry harvester. The two joysticks to the lower left are both located in wheel loaders. They are defined as regular joysticks; the upper is made by LiuGong, and the lower by CAT. The two images to the lower right are defined as mini-joysticks. The upper image is located in a John Deere harvester and the lower image is from a Valtra tractor.



# 3 Theory

The theory research gathers facts for a deeper understanding of the ergonomic limitations of human physics and also describes what aspects that are important for cognitive ergonomics. Regarding the physical ergonomics, the anatomy of the hand and hand function is presented together with factors that impact the workload. A summary relates the facts to the work in wheel loaders and encloses what ergonomic issues that exist today. The cognitive ergonomics chapter presents theories of perception processing and why mental models should be studied. The cognitive ergonomics chapter mostly explains terms and concepts and why they are used in this project. A chapter of standards and recommendations from literature studies, related to wheel loaders and control lever design, summarize the theory chapter.

## 3.1 Physical ergonomics

The control lever unit mainly involves the use of the hand and requires dexterity and precision from it. Therefore it is important to consider the variables in hand work to understand what influences effectiveness, comfort and efficiency of hand related work (Haslegrave & Pheasant, 2006). The overall work posture – especially the position of the arm will have effects on whether the operator will experience discomforts or not. The overall work posture is related to the chair and the armrest, which is outside of this project scope, and will therefore not be included in any deeper analyze. Forestry machines, such as forestry harvesters facilitates a work situation that is not identical, but in some aspects similar to wheel loaders. Some research has been done on this topic in an ergonomic aspect and some of this research relevant for the project is used in this chapter.

In several situations there is useful to use planes to describe postures or other movements. Well-recognized plans that relate the human body to the surrounding world are the following (Leonard, 1995):

- 1: the sagittal plane that divides the body in the left and right halves
- 2: the coronal (or frontal plane) divides the body into the front and back halves
- 3: the transverse plane is horizontal that divides the body into the upper and lower halves.

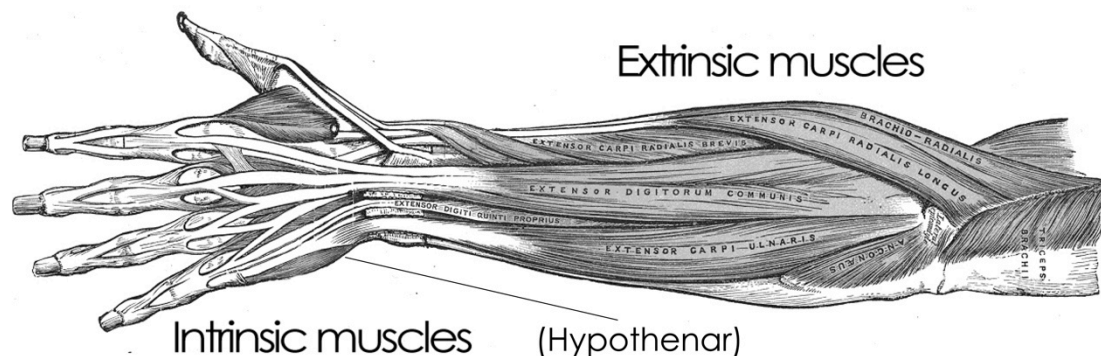

Figure 3.1 Muscles (Bartleby 1918)

### 3.1.1 Anatomy of the hand

The hand consists of many parts that work together to perform the functions needed for daily activities, the most visible part being the skin.

The fingers have the second most amounts of touch- and thermo receptors in the human body. They are very sensitive to touch, temperature, vibration and more. The fingers themselves do not contain many muscles but are controlled by long tendons that come from muscles in the hand and forearm (SCOI, 2010). These muscles are divided into intrinsic and extrinsic muscles, (*figure 3.1*). The intrinsic are inside the hand while extrinsic are placed in the forearm and connect to the hand by long tendons. One intrinsic muscle group is the hyposthenia seen in the image. The muscles in the arm do the large movements of the hand while intrinsic muscles control side-to-side movements of the fingers and thumb. This also have the consequence that pain in the forearm muscles are related to ergonomics of the hands.

### 3.1.2 Hand function

According to Haslegrave & Pheasant (2006) the hand is complex and designing hand tools may require many different measurements to be considered when designing tools, controls or parts for assembly. Theory research of different grips and the movements the hands are able to perform, give a basis for the work ahead.

#### Grips

Attempts at defining the large number of actions capable by the hand have not resulted in a finite number of grips. There are however a few basic definitions: gripping and non-gripping actions such as poking, pressing, stroking etc. Gripping actions create a “closed kinetic chain” that hold objects in place. The non-gripping actions fall instead in the “open chain” category. Gripping is divided into two categories: (*figure 3.2*)

*Power grips:* objects are held against the palm using the fingers and thumb.

*Precision grips:* objects are held with the tips or sides of fingers and thumb.

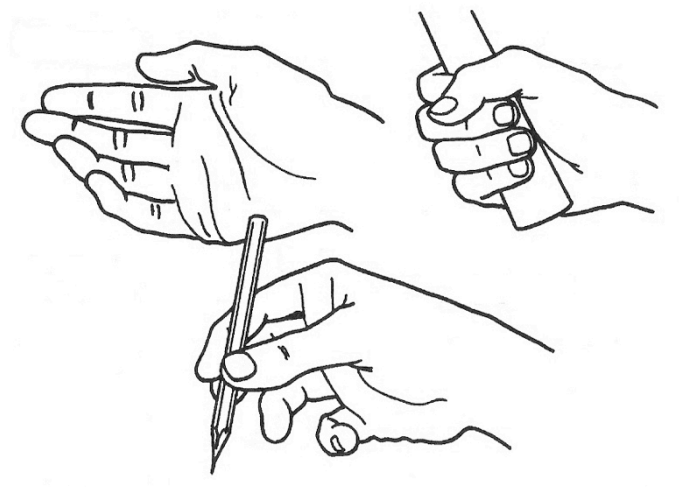

*Figure 3.2 Hand grips (Osvalder & Ulfengren 2009)*

## Angles of movement

The hand has the ability to perform a wide variety of movement that requires a wide area of different combinations of movement. The movements of the hand are described by deviation from its normal position. *Figure 3.3* explains the voluntary movement of the hand (in general the more the hand deviates from the normal the worse that position is). The hand is the most relaxed in its position of rest, which is when the hand is in equilibrium, meaning that the muscles that flex and extend are in balance (Haslegrave & Pheasant, 2006). This means that neutral forearm rotation is a pronated rotation.

### 3.1.3 Workload in wheel loaders

Factors that affect hands ergonomics particularly in wheel loaders must be researched further. Previous theory regards the hands anatomy and function and this chapter reviews the biomechanical factors, static workload and other reasons for discomforts.

#### Hand injuries

According to Haslegrave & Pheasant (2006) aspects such as size, shape and friction will affect the ability and precision of exerting force. Grip strength is for instance the strongest with hand and wrist in neutral position. This is then reduced as the wrist moves away from the neutral in any direction. In flexion the strength is the least due to the finger flexors are shortened. The contact surfaces for the tendons are also increased as the wrist moves away from the neutral. This will cause more friction, overuse and extension of the tendons which will in turn cause musculoskeletal disorders such as carpal tunnel, tenosynovitis or other disorders related to overuse. (Haslegrave & Pheasant, 2006). And as Adolfsson et al (2004) also claim, the hand is constructed for *gripping* - the muscles for extension are weak and imprecise.

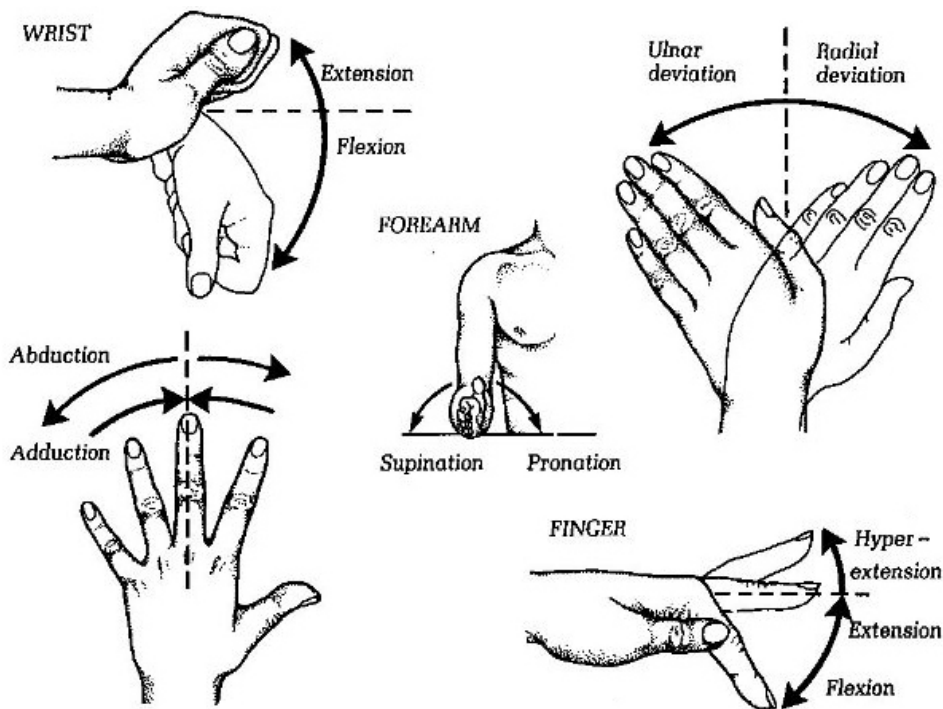

Figure 3.3 Terminology angles of movement (Assb 2009)

### **Actuating forces in levers**

In ISO10968 (2004) the recommended actuating force for hand-operated levers should be in the range of 15 N to 230 N in forward or backward movements, or between 15 N to 100 N when moving the levers sideways. Levers operated by fingertips should have an actuating force between 2 N and 20 N. In the ergonomic study by Adolfsson et al (2004), the actuating force in wheel loaders' linear levers were measured to 15 N. The fingers control these linear levers, and that should mean that the actuating force is at the most around 7 % of maximal muscle activity ( $15 / 230 \approx 7 \%$ ). The forces in today's levers are thereby considered low.

### **Static workload**

One of the main characteristics for static work is that only a single or few working tasks are performed with similar repetitive movements for the large duration of the day. The work cycle time for each repetition is very short meaning that there is a high tempo in the work. Examples of static work are: assembly work, checkout registry workers, computer typing and certain vehicle operations fall under this category as well. Work in many forestry machines incorporate monotonous work with high precision requirements. By repeating the same movement, a continuous strain is created even with small forces involved. The result is gradually increasing strain and injury with a long recovery times as result (AFS, 1998). According to Adolfsson et al (2002) the levers are used for up to 95 % of the operating time. In the study, five of the ten subjects have had musculoskeletal discomfort during the last twelve months; two have had discomforts in both wrists. Both joysticks and linear levers were studied and the results were primarily identical.

### **Other factors than biomechanical**

As Winkel et al (1998) state, the muscle activity for forestry machine operators or wheel loader operators may not be possible to decrease below the 2 – 4 % of maximal muscle activity. Instead many other factors affects the ergonomic other than biomechanical, such as cognitive demands, perception, and demands of high precision and coordination. A high level of perception and cognitive awareness is required when operating the machines. Factors that might impose discomfort in shoulder/neck are (Winkel et al, 1998):

- Fine tuned exact movements of levers
- High working tempo
- Arm-hand coordination
- Low variability of posture
- Substantially increase level of lever maneuvering.

### 3.1.4 Ergonomic issues related to the wheel loader operators

Previously stated factors for discomforts or even injuries are also verified for wheel loader operators. This chapter encloses the ergonomic issues related to wheel loader work, and also relates this kind of work with similar work in forestry machines.

#### **Common symptoms of injuries for wheel loader operators**

In a study performed by Adolfsson et al (2004) 50% of the operators have suffered from injury symptoms in the neck-shoulder area. Additionally, neck, shoulder, forearm and lower back discomfort are reported (*table 3.1*). Wheel loader operators have more often troubles with wrists and elbows than forestry operators who's work often are compared to wheel loader work in literature. Older studies report that forestry operators with armrest-supported levers have had higher frequency of pain than lumberjacks and office personnel. The reason is that the work demands a high cognitive workload with coordination of the limbs combined with visual intake and vibrations. The hands must perform fast with exact movements, repetitive for long hours and this puts strain on the whole arm (Adolfsson et al, 2004).

*Table 3.1 Musculoskeletal symptoms (Adolfsson et al, 2004).*

<b>Musculoskeletal symptoms during the last 12 months (2004)</b>						
<b>Type of driver</b>	<b>Neck %</b>	<b>Shoulders %</b>	<b>Elbow %</b>	<b>Wrist %</b>	<b>Back %</b>	<b>Knee %</b>
<b>Wheel loader</b>	50	25	50	38	38	38
<b>Forestry Harvester</b>	50	50	0	0	50	25
<b>Total</b>	50	38	25	19	44	31

#### **Differences between forestry work and wheel loader work**

The large difference in symptoms between the two professions regarding wrist and elbow could be explained through the difference in working tasks even though the levers and working area might look the same: During forestry work the machine remains sedentary while the operator controls the tools using small movements at one time to perform the tasks needed. Wheel loader operators drive while loading different items and perform large movements with the tools to be able to work as fast as possible while being exerted to vibrations and shaking of the entire working area.

## Reasons for discomforts in wheel loader work

According to Hägg (2009) something that in the beginning might appear as a dynamic working task, such as manipulating levers with a forward abducted posture, might in fact be considered a static task from a physiological point of view: An unchanged force level in the shoulder muscles in such a task gives a continuous workload i.e. static work. In the operators work situation, with small actuating forces that might not be able to decrease any further, there is still a risk of static workload injuries: a hypothesis named the Cinderella Hypothesis explains how these low forces can cause injuries. The first muscle units activated by the work are also the last units to rest – this is in analogue to Cinderella's working sessions. The muscle unit is defined as a bunch of muscle fibers and accompanying nerve cell that is the smallest part of the musculoskeletal motion apparatus that is able to induce a force. The first muscle units activated are in use for minimum force required such as fine motoric precision work. When higher forces are required, more and more muscle units are activated and the first units continue to be activated and used for the longest time. The hypothesis says these muscle fibers are the ones first to be injured, called Cinderella fibers (Hägg, 2009). The reason for the discomfort is the high demanding cognitive workload, coordination of limbs combined with visual intake and vibrations. The hands must perform fast and exact movements repetitive for long hours and this puts strain on the whole arm (Adolfsson et al, 2004).

### 3.1.5 Previous research related to joysticks

Important notes found from research done on single levers in similar work conditions as in wheel loaders are relevant to present. The project does not require specifically a joystick to be designed, but this is the commonly used design solution so existing research results are examined. This gives a theoretical frame of reference for advantages and disadvantages to consider in the succeeding work.

Attebrant et al (1998) investigates control levers and armrests in forestry machines, and analyzes joystick usage. Several different muscles around the shoulders, down to the hand, were measured using EMG. Several of these muscles' workload seems to be decreased or at least, preserved with mini-levers and movable armrests in the sagittal plane. Regarding to Mean Static Load (MVC) and cycle time, MVC was decreased, but by small measures. So, mini-levers stress the body a bit less than conventional hand levers. Also Adolfsson et al (2004 p.26-p.32) state that the maximum work movements of the arm, hands and fingers are slightly reduced when using joysticks instead of linear levers in wheel loaders, and in all smaller lever results in smaller movements. But, forestry machine operators using mini-joysticks exhibits joints with more static work positions, so small levers also requires better support for the arm to support these body parts. Neither linear levers, joysticks, nor mini-joysticks seem to induce risks for serious injuries when using them in this work conditions.

## 3.2 Cognitive ergonomics

It seems that today the problem with the lever work is more of the discomfort type and ergonomic issues cannot be regarded as occupational diseases. But the previous theory regarding existing research on physical ergonomics, also revealed that also cognitive demands, coordination of the limbs and demands of high precision are factors that impact the workload and the ergonomics. Later in the report, the cognitive ergonomics are analyzed to give input for concluding the whole work situation (*chapter 6.4*).

The theoretical basis for that analyze is not as thoroughly described as previous chapter on physical ergonomic theory, mostly because of the lack of research in this area. This chapter mostly describes terms of concepts that is commonly used in cognitive ergonomics and also used in the report. At the end, the important conclusive reasons for an ergonomic research are given.

### 3.2.1 System theory

Sanders & Maccormic (1993) claim that System theory calls for interacting parts to be studied as a whole. This mean that a factor impacting the ergonomics should not be studied isolated, but instead all factors studied together. The definition of a system, used in this project, is different participants working together as mechanism, to accomplish a goal that the participants could not reach by them selves, adopted from Sanders & Maccormic (1993) and Flood & Carson (1993).

### 3.2.2 Mental models

According to Sasse (1997) mental models are descriptive representations the user has of the reality. Mental models are developed by users in order to have control over a work process. Also designers, researcher and any human in contact to a system use models in interaction between human and machines. According to the author, the definition of the user's model is incomplete and only an interpretation made from the researchers own model. Although, this simplification of the real system (in the domain of the work situation) helps users to understand the situation and what will happen in the system. This is developed during interaction with the technical system (Andersson 2010).

### 3.2.3 Top down and bottom up processing

When processing data from physical stimuli, two processing concepts interact. If no additional data is needed, the processing is performed unconscious and automated, called *Bottom-up processing*. Prerequisites for bottom-up processing are good quality data and contrasted stimuli. In the process no additional data is required for the human to perceive and understand the situation

If cognitive capacity is required to construct a mental model or recalling additional data to the perceived stimuli, it is regarded a *Top-down process*. In this case information is missing and the conscious is more active to perceive the situation and use previous experience instead (Osvalder & Ulfengren, 2009).

### 3.2.4 Natural mapping

Mapping is a concept that describes a way of perceiving and acknowledging a change to the world, made by the user that is manipulating the system. In other words, the way that something outside, which is controlled by the user, reacts to the actual controlling. A natural mapping is the reaction that can be regarded as in direct analogue to the controlling: to move an object up, move the control up (Norman 2002). If a good and natural mapping is present, the top-down processing is decreased. This has positive effects in learning curves, decreased risks for human errors etc.

### 3.2.5 Cognitive ergonomics in wheel loaders

Conclusively, the wheel loaders are affected by demands on their work; they have to perform with time pressure and they have to perform precise movements etc. all of that can be found in the research described in the physical ergonomics chapter (*chapter 6.2*). The cognitive processing related to this is how the operator perceives the world outside the system where he is situated. The kind of processing, top-down or bottom-up, determines how fast the user understand the world and how the human-machine system is changing the world. This change is created by the system the user is control of by maneuvering the levers. The interaction between the human and the machine is physical through the levers, but in order to control the wheel loader with precision and also fast enough, the user must have expert skills to control it and there is where cognitive ergonomics play a part for learning the skills fast, but also facilitate safe and easy use.

#### **Cognitive issues to consider in wheel loader usage**

Therefore, the system must be described and a description of a mental model is needed to see what requirements there are on levers for good controlling. If researchers can derive users' mental model, the skills only expert have can be revealed and be used in product development. A natural mapping between the interaction and the wheel loader is an adequate requirement, but it is not yet established how this requirement can be implemented in the development. A new lever also means a new interface of control for the user. So, any aspects of the perception and interaction related to common tasks in wheel loader should be investigated for the design to be successful. Aspects of interest regarding cognitive ergonomics are:

- The operator's perception of the world and the system
- Operators most important senses used in the work
- The mental models used when controlling the wheel loader and attachments.



## 3.3 Standards and recommendations

To enclose theoretical aspects for a redesign of a lever, different recommendations available are summoned, both from articles related to wheel loaders and forestry machines, and also from contacts with expertise. The resulting data of interest, that is the data relevant for the continued project and this report is summoned in *table 3.1*.

### 3.3.1 Literature review

The levers design and use are in analogue closest to *handles*, on which there are standards and recommendations available in the literatures. *Bodyspace: anthropometry, ergonomics and design of work*, by Haslegrave & Pheasant (2006), is a comprehensive book over ergonomics and describes different recommendations regarding handles. The purpose of a handle is to facilitate the transfer of force between the musculoskeletal system of the user and the handle. There are many ergonomic concerns when designing handles, in terms of effectiveness of the tool itself, repetition of hand movement, hand postures that deviate from the normal, static muscle loading as well as tissue compression. Also vibrations and large forces have a considerable impact on the hand. However many of the common rules for designing handles are often left out and forgotten (Haslegrave & Pheasant, 2006).

As the wheel loader might be subjected to conditions that induce discomforts and the work could be regarded as a static workload according the Cinderella hypothesis (Hägg, 2009), recommendations of measures for static work should be reviewed: Immediate steps are to reduce the overall time and repetition of the specific task in question. This often requires some kind of organizational changes to improve the variation of tasks, involvement and development of the workers. The work should be in short instances spread throughout the day interrupted by breaks and pauses. Work ergonomics, in Swedish Arbetarskyddsstyrelsen (AFS), has a mission to improve the work ergonomic in Swedish work places. AFS (1998) describe the most important points for the employer, to minimize the risk for work related injuries, for hand tools and other measurements regarding most aspects of the work such as static workloads. In a project by Adolfsson et al (2004) the aim was to distillate guidelines or to propose ergonomic designs for armrest-mounted levers in wheel loaders and forestry machines. It compared mini-levers, linear levers and joysticks and measured target users joint angles when using them. Body stature and hand length has an effect on placement of armrests and levers and good ability for adjustments was regarded a vital feature.

From a study by Gellerstedt (2000) the operators themselves verbalized a couple of needs for forestry machines that could be concluded to some recommendations.

Table 3.1. List of recommendations

	Expressed recommendations	References
1	Design of a buttons' positions, shape and surface must be performed in such way that the tactile sense and positioning sense automatically sense and interpret a pattern. Multiple references of tactility are recommended when button don't follow the lever/joystick	Adolfsson, Öberg och Torén (2004 p. 10-12)
2	The four most important buttons should be placed corresponding to the relaxed hands finger placement.	Adolfsson, Öberg och Torén (2004 p. 10-12)
3	An angle of 100 -110° for the elbow angle is recommended during lever work.	Adolfsson, Öberg och Torén (2004 p. 10-12)
4	The angle from the transversal plane to the hand should be around 10-20°.	Adolfsson, Öberg och Torén (2004 p. 10-12)
5	The angle from horizontal to a pistol grip should be 70°.	Gilbert, Hahn & Gilmore (1988)
6	A joystick or lever should keep the wrist in angles as close to neutral plane as possible.	Göran Hägg <sup>1</sup> , Ralf Rosenberg <sup>2</sup> , AFS 1998, Adolfsson, Öberg och Torén (2004 p. 10-12)
7	Exert force in a 90-degree angle against an axis rather than along it.	Haslegrave & Pheasant (2006)
8	Sharp edges on pressure surfaces should be avoided to eliminate force hotspots (finger grooves, handle shapes etc.).	Haslegrave & Pheasant, (2006). AFS (1998)
9	Handles should give good grip and adhesion for precision.	AFS (1998)
10	The thumb can maneuver two buttons or one toggle switch	Adolfsson, Öberg och Torén (2004 p. 10-12)
11	Avoid extended postures of the wrist if designing mini-joysticks.	Adolfsson, Öberg och Torén (2004 p. 10-12)
12	Avoid joysticks for just two hydraulic functions	Adolfsson, Öberg och Torén (2004 p. 10-12)
13	Handles for gripping should have a diameter of 30 – 50 mm	Haslegrave & Pheasant (2006)
14	Precision handles should be between 8 – 16 mm in diameter	Haslegrave & Pheasant (2006)
15	The levers on the control unit should be adjustable for different hand sizes or fit a wide spread of hand sizes	Gellerstedt (2000), AFS (1998)
16	Activate many muscles for one movement, but the arm should not move at all, and the forearm to a minimum	Ralf Rosenberg
17	Arm and shoulder should be fully supported to avoid static workload.	Ralf Rosenberg
18	Job rotation. Other tasks that differs from each other.	AFS (1998)
19	Small beaks in the work, so called "Micro-brakes" would be preferred.	Gellerstedt (2000)
20	Handles used in gripping should have a slight curvature (but not create hotspots) to follow the shape of the hand. <sup>25</sup>	Haslegrave & Pheasant (2006)
21	The cross section of a handle should be somewhat egg-shaped to set the direction of the handle.	Haslegrave & Pheasant (2006).
22	The angle from transverse plane to pistol grip should be 70°.	Gilbert, Hahn & Gilmore (1988)

<sup>1</sup> Göran Hägg, Professor, KTH, verbal contact (mail) 27<sup>th</sup> of September 2011

<sup>2</sup> Ralf Rosenberg, Designer Msd, Chalmers, verbal contact 27<sup>th</sup> September 2011

# 4 Methods

*This chapter consists of descriptions of the methods used in the project. More detailed descriptions of the execution of the methods are presented in the report in the respective chapters where they are used. The methods are grouped depending on their purpose or outcome from the methods: data collecting, analysis methods for ergonomic issues, idea generation and concept evaluation methods.*

## 4.1 Data collecting methods

These methods are used for collecting information of the human-machine system and the work situation. They regard people's thoughts and interaction with the system.

### 4.1.1 Observations

To study phenomenon or events, different technical aids can be used in addition to the human senses when observing the situation. Observations can be performed with different levels of participation, and the subjects can more or less be aware of the fact they are being observed (Höst et al, 2006). Observations made in this project were executed as participating observations with aids such as video recorders and additional questionnaires and semi-structured interviews. This means that the observers had low interaction, and the observed subjects were fully aware of the observers

In this project the first observation session was made to study hand postures of the operators (*Chapter 6.2.3*), the second observation session was made to understand the operators' mental model (*Chapter 6.4.2*) and the last observation session was made to study hand postures of the reference group when evaluating the first prototype (*Chapter 11.2.2*).

### 4.1.2 Questionnaire

A method for collecting data for a large number of people with most common pre-defined and set question is by using questionnaires. These questions are answered by the interviewee himself/herself. Questions, or statements, must be short, simple, precise, straightforward and not leading, among other aspects. A common way to collect data on opinions is let the interviewee take side to a statement, by using a so-called Likert-scale; the user can agree, or not agree (to some extent) to the statement. This scale is often discretizes into intervals of five or seven degrees, from fully-agree to not-agree (Höst et al, 2006).

Questionnaires were in this project used as a compliment to the observations and as a support for the semi-structured interviews. Questionnaires were used to gather subjective input of the operator's perceived discomforts (*Chapter 6.3.3*). Questionnaires were also used during the concept generation phase when the reference group evaluated the concepts (*Chapter 8.3 and 9.3*) and during the concept evaluation phase when the reference group evaluated the functional prototype (*Chapter 11.2.4*).

### 4.1.3 Semi-structured interview

Interviews can be used as a data collection method for subjective data to gather knowledge about e.g. people's experience, values and opinions. A semi-structured interview has both predefined and open questions making it possible for the interviewer to follow up on responses and ask follow-up questions. This interview form is good when the interviewer wants a deeper understanding within the area (Osvalder et al, 2009).

In this project semi-structured interviews were used to gather information about machine operators and wheel loader usage (*Chapter 6.2.1*), to understand the operator's perceived discomforts (*Chapter 6.3.3*) and to understand the operator's mental model (*Chapter 6.4.2*). Semi-structured interviews were also used during the concept evaluation phase to understand and elaborate the operator's answers from questionnaire (*Chapter 11.2.4*).

## 4.2 Analysis methods

The methods in this chapter are used for analyzing situation in ergonomics' perspective. Different outcome is expected from the methods, but all is used for the purpose of analyzing the current situation and give basis for the concept development. The methods are describing users and tasks; give anthropometric data; evaluate the physical workload and simulate ergonomic situations.

### 4.2.1 Anthropometric analysis

This concerns the human's different measurements and proportions of the human body within different populations, in particular the human body's size, shape, strength and work capacity. It is used in industrial design and ergonomics by statistic data and distribution, which is used to optimize a product for a specific population (Pheasant, 2006). Validity in anthropometric studies relies on data of measurements, characteristics of the user population (Osvalder et al, 2009). The purpose with an anthropometric analysis is to retain important anthropometric measurements relevant for the concept development.

In this project the anthropometric analysis was made to gather anthropometric data of the hand from the 5<sup>th</sup> to 95<sup>th</sup> percentile of the world's population (*Chapter 6.3.2*).

### 4.2.2 Applied Cognitive Task Analysis

Expert knowledge can be elicited by a structured method called Applied Cognitive Task Analysis (ACTA). The ACTA methodology used in this project is derived from Klein (1997) with: *Task Diagram*, *Knowledge Audit* and *Simulation Interview*, to collect data. By using a *hierarchical abstraction*, the mental model can be described:

*Task diagrams* have the purpose of being a map over the sequence a map for the rest of the method. The expert divides the task in three to six sub – tasks and those that require cognitive skill (e.g. judgments, assessments, problem-solving), are defined by the user.

*Knowledge audit* reveals what the expert knows and what aspects of expertise that is required for the tasks. The interview probes how situations are diagnosed, about the overall understanding, certain perceptual skills needed, about improvising etc.

*Simulation interview* gives users view of the problem in a context, probing the cognitive processes in a specific scenario. This highlights cognitive elements and how user experts think in the situation.

*Abstraction hierarchy* can describe the reality; thereby also describe the users' mental models. The abstraction of a real situation is hierarchical analyzed into different levels of understanding. According to Andersson (2010) each level explains *why* the level below is needed and explains *how* the level above is performed. The levels are:

1. Situation – Describes the overall goal.
2. Task – Represents what is being performed.
3. Function – represents the reason for a process or structure.
4. Process – Represents what happens when using the structure.
5. Structure – Represents the physical objects.

In this project ACTA was used to understand the operator's mental model and to understand the differences between an expert and a novice operator (*Chapter 6.4.2*).

### 4.2.3 Hierarchical Task Analysis

The Heuristic Task Analysis (Later just HTA) is a useful method to give structure and give a detailed understanding of the task and an understanding of the users' work situation, as well as the human machine interaction. The user must reach different sub-goals in order to perform a task in the work; the HTA reveals and defines these sub-tasks and operations. The sub-goals needed to fulfill each overall goal, must be performed in order (Osvalder et al, 2009).

In this project HTA was used to understand common tasks performed when operating wheel loaders and what is required by the operator to perform these tasks (*Chapter 6.2.2*).

### 4.2.4 Jack version 6.1

This is a computer aided simulation tool for ergonomic evaluations, first developed in the 1980s at the Centre for Human Modeling and Simulation at the University of Pennsylvania. The reality can be modeled within the software or by importing external files. The human mannequins built in the software and are manipulated to fit this environment, and integrated anthropometrical data, as well as ergonomic analysis tools such as RULA or Comfort angles are available for ergonomic evaluation in the simulated reality. Today the software is developed and marketed by Siemens (Blanchonette, 2010).

In this project Jack was used to replicate the work posture found during the observations, to measure the comfort scoring of that posture and to find a new posture that would incorporate a better comfort scoring (*Chapter 6.3.1*). Jack was also used to visualize the anthropometric variation of the 5<sup>th</sup> to 95<sup>th</sup> percentile of the world's population using the data gathered in the anthropometric analysis (*Chapter 6.3.2*).

### 4.2.5 Rapid Upper Limb Assessment

Rapid Upper limb Assessment (RULA) is one of the most commonly used and well-recognized methods for evaluation of the human body's strain in a work situation. RULA is focused on the upper body, totally seven regions of the body is rated. The method rates joint angles by a defined scale in a protocol, and the ratings for each body region are later summoned to final score. This final score can be compared to a scale for

actions to depending on the angles. (Osvalder et al, 2009). RULA has a subjective aspect in the ratings, so it must be regarded a semi-objective method.

In this project RULA was used to analyze the work postures of the reference group from the observations in the evaluation of the functional prototype (*Chapter 11.2.3*).

#### 4.2.6 User Profile

The method User Profile is used to present data about user characteristics. A user profile should contain data about the user's background, the usage and experience of the product, what influence and responsibility the user has towards the product, what kind of emotional relationship there is between the user and the product, how the user interacts with the product and what goals the user has when using the product.

A product can have many types of users, not all even being in contact with the product. The users can be classified into four roles; Primary user, secondary user, Side user and Co-user. The primary user is a person who uses the product for its main purpose. A Secondary user uses or might get in contact with the product but not for its main purpose e.g. a salesman or a repairer. The product might affect a side-user without being a primary or a secondary user e.g. someone living next to a noisy road (a car being the product). A co-user collaborated with the primary or secondary user without being in contact with the product. (Osvalder et al, 2009)

In this project the user profile was used to understand the prerequisites of wheel loader usage and who the machine operator is (*Chapter 6.2.1*). As a support to this method semi-structured interviews were made with a salesman of wheel loaders, a repairman and several Swedish machine operators in the Gothenburg area.

### 4.3 Idea generation methods

Methods used to generate ideas and finding solutions is presented here. These methods help method users to systematically find solutions, or let the participants go into idea generation phases with a certain attitude. Heuristics and guidelines are not a generally well-known methods, but the project uses them for aiming the idea generations.

#### 4.3.1 Brainstorming

This is the most recognized method to find a lot of solutions in creative sessions, where criticism is absolutely forbidden during the session (Österlin 2007). The problem to find solutions for, is phrased as a question; "how can we open product A?" (Cross, 2008, p. 48-51). For this project the brainstorming was not performed as an isolated method with external participants, and the solutions were often sketched instead of verbalized or written (*Chapter 8.1 and 9.1*).

#### 4.3.2 Design heuristics and guidelines

The design heuristics is regarded general aims to fulfill stated needs, and not an ideation method, although they are important for that phase. In the concept development these heuristics will be more and more defined depending on chosen ideas and concepts. This project uses the term heuristics for the defined aims to fulfill needs, and the term guidelines if a specified design feature, such as measurement is tested in the project (*Chapter 7.2*).

### 4.3.3 Morphological matrix

Morphological matrix is a systematic method for generating new ideas. The method is based on combining part-solutions into total-solutions – giving many different total-solutions based on how the part-solutions have been combined. First, sub-functions should be generated. For each sub-function several sub-solutions are generated. The sub-solutions may advantageously be clarified with simple sketches. The sub-functions together with the respective sub-solutions are then placed into a “morphological matrix”. In the morphological matrix polygons is drawn through the sub-solutions in the matrix generating in several total-solutions. The total solutions are then sorted out based on either how well they meet requirements or just for obvious reasons. (Johannesson et al, 2004)

In this project a morphological matrix was used to find new solutions in the idea generation phase after having selected one concept approach to further develop (*Chapter 9.1*).

## 4.4 Concept evaluating methods

Methods that are specially used for evaluating concepts are presented below. The most common method used for this in the project is the concept screening, but other resources were available in this project.

### 4.4.1 Concept screening

To evaluate concepts in early stages, matrices are often used. The Concept screening is a fast method, adopted by Ulrich & Eppinger (2008), where concepts are evaluated by how well they satisfy different criterion. The criterion is related to needs or requirements, and a concept gets a plus, minus or zero. It gets a zero if it fulfills the criterion as good as a reference, or plus if it fulfills it in a better.

In this project concept screening was used to evaluate the concepts from the two first iterations in the concept generation (*Chapter 8.3 and 9.3*). The criterion used in the screening was selected based on the needs from the problem definition (*Chapter 7.2*).

### 4.4.2 Prototype rig

A metal frame construction with an armrest identical to the ones in Volvo's Wheel loaders, were available for evaluating purposes. This *rig* has a right side armrest fitted in the same height and with same adjustment abilities as the armrests of current products. The future product must fit this type of armrest. This gives a mounting point and acts as a reference for instant evaluation of mock-ups and prototypes.

In this project the prototype rig was used in the concept generation phase during the workshop sessions when evaluate the mock-ups (*Chapter 8.1 and 9.1*), when evaluating the concepts with the reference group (*Chapter 8.3 and 9.3*) and when developing the functional prototype (*Chapter 10.2*). It was also used when developing the final concept (*Chapter 12.2*) and when validating the design changes with the reference group for one last time (*Chapter 12.4*).

### 4.4.3 Prototypes

In this project, the definition of prototypes is adopted from Ulrich & Eppinger (2008), where a prototype is regarded as an approximation of the concept as finished product. As the authors describe, prototypes can be divided into *analytical prototypes* and *physical prototypes* and divided further depending on the intentional use. Especially the physical prototypes are used for evaluating ideas and concepts in this project.

*Analytical prototypes* are in this project sketches and renderings, mostly used to communicate a mental idea for the concept.

The *physical prototype* is an artifact that has a form, and is something that can be touched, held and sensed.

How many of a product's attributes the prototype implements, is differentiated as the prototype being *focused* or *comprehensive*, whereas the focused one only have few attributes.

In this project, the term *mock-up* (Chapter 8.1 and 9.1) has been used when building simple prototypes to try out ideas, determine the overall shape and to accommodate buttons and switches. The term *prototype* (Chapter 10.2 and 12.2) has been used for a physical prototype that has as many attributes of the real, finished product as possible. Two materials have been used in this project; a blue colored polystyrene foam (PS) for *mock-ups* and a peach colored polyurethane foam (PU) for *prototypes*. The blue colored foam is good when wanting to create fast shapes. It is light and easy to work with by hand and can be cut with a paper knife. The peach colored foam has a much higher density and is similar to wood when working with (except it doesn't have a fiber direction which makes it easier to work with than wood). The peach colored foam requires machines to form, if wanting to work with it by hand it is tough and time consuming. CPAC has provided the project with existing joystick bases, buttons and sensor that is possible to use in a future product either directly or with smaller mechanical or electrical design changes. As this pre-study is not able to develop new such technical solutions, these have been used for try-outs and evaluations in the prototypes.

### 4.4.4 Reference group

The project relied on a reference group to evaluate concepts. Seven participants, all employed by Volvo CE, working as test engineers, product developers or project managers. All participants were men in the age from 27 to 53 years old, were the median value of the age was 41 years old. Their experience of operating a wheel loader varies from 1 year to 25 years, were the median value is 11 years. How many hours a week they have operated a wheel loader varies from 1 to 40 hours a week, were the median value is seven hours a week. Three of the participants had minor experience from using a single lever before.

The reference group was used to evaluate the concepts from the two first iterations in the concept generation phase (Chapter 8.3 and 9.3). The reference group was also used when evaluating the functional prototype in a machine (Chapter 11) and finally to validate the design changes made in the final concept (Chapter 12.4).



# 5 Project implementation

*This chapter describes the procedure of the work with a model and relates the model to this report's outline. What phases that were implemented, and why they were implemented, are briefly described after the procedure model.*

## 5.1 Description of procedure

At the start of the project the planning was adapted to fit an existing development project plan. The model (figure 5.1) is a simplification of the practical work that had the first phases done in parallel, but the essential workflow is represented, with the Problem definition as the end of the pre-study and as the start of a concept development.

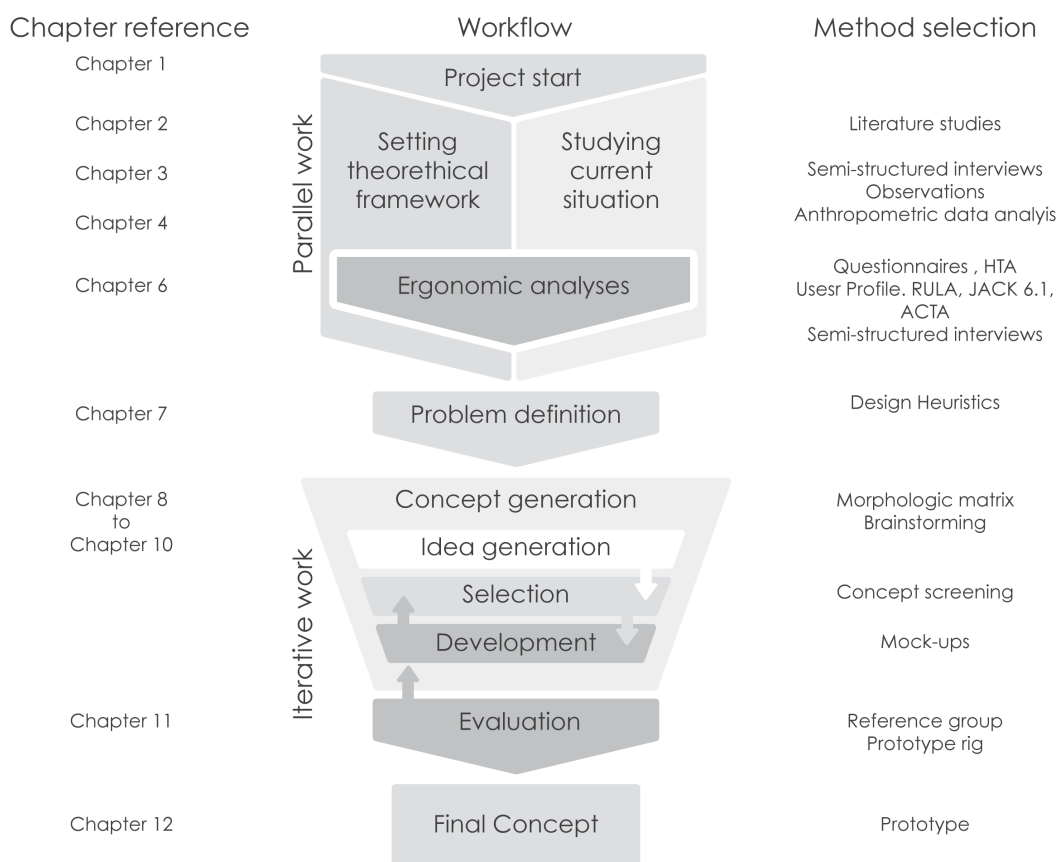

*Figure 5.1 Model of the workflow*

*The workflow is simplified into the different phases seen in the model. Phases that has taken the greatest effort to perform is perhaps ergonomic analyse, the development of feasible prototypes and evaluation of the prototype. The corresponding chapters to the project workflow are seen to the left of the workflow model. A selection of typical methods for each phase is seen to the right, although several results are used in more than one phase and some methods have also been re-used in other phases.*

## 5.1.1 Explanation of different phases in the process

### **Studying the current situation**

One of the first stages in this project was to gather information of the current situation and research literature related to wheel loader work of similar ergonomic situations. Interviews of Volvo resellers took place to gather the information and also observing end-user gave a lot of information to the project.

As the needs a product must fulfill must be defined, studying the current situation and literature studies forms an understanding of existing functional requirements of control levers in wheel loaders.

### **Setting theoretical framework**

Literature studies of human anatomy were performed early in the process, at the same time as the current situation were studied. The source for both phases were at first the same, but later ergonomic issues and facts, such as design recommendations, were gathered by reading reports regarding operators ergonomic work situations. Methods for ergonomic analysis are also the outcome of this activity.

As the purpose mainly regards a product that has to be ergonomically designed, a gathering of ergonomic issues and facts gives a theoretical basis for the analyses. Methods to use and how to apply these are given from the theoretical research. Also, studying the anatomy and literature related to the project's purpose give insight in what recommendations to use. This part of the pre-study gives theoretical input of how to design a product for the current situation.

### **Ergonomic analysing**

A set of methods was used to analyze the user's current situation. The current situation was analyzed with analytic methods both for physical and cognitive ergonomics. The theoretical background was the basis, but the methods gave the desired details of this particular situation. Observations and methods with user interviews were carried out. The user and tasks they perform were analyzed from the cognitive aspects and simulated in CAD software to analyze the physical aspect. Anthropometric data and subjective input from operators in real situations were derived in this phase.

The previous chapters have given the basis for the project. The analysis has several purposes. First, the ergonomic issues determined in *chapter 3.1.4* should be confirmed, and the analysis is required to find problems specific for this project to solve. Secondly, also the reasons should be found to know what the problem is. And third, some information on how to succeed with a new design must be found.

### **Defining the Problem**

The theoretical study and analysis were synthesized into a conclusive problem definition. This stated the needs to fulfill with the future product, and in some way also how a design could fulfill the needs by design heuristics.

The synthesis gives a description of the problem and connects the different parts of the previous work. This gives basis for the concept development; what needs to fulfill and an aim to how the needs can be fulfilled.

## **Concept generation**

*Idea generation* presents gave a lot of ideas. Some ideas fulfilled one or more need defined in previous phases. By integrating them into concepts and *select* those of most interests by evaluating methods, gave the best concept from that iterations. From every iteration cycle some ideas were kept to the next iteration or combined into a more and more comprehensive concept of the solution to the problems.

Idea generation without any consideration of feasibility of criticism, and later combine them, gives a wide spectrum of concepts with more or less innovative potential. The selective part can then sort out the most feasible. *Development* of prototypes is needed to really test the feasibility, see next chapter.

## **Development of prototypes**

Mock-ups in polyurethane foam of different densities, wood and plastics together with available sensors and joystick bases, realized a lot of ideas. The mock-ups were made of different detail levels depending on what iterative loop they were built in. Finally, some prototypes also were made with joystick-bases, handle, buttons and also mounted to the rig. These prototypes were evaluated also by the reference group.

To know if an idea that is just sketched up on a piece paper, could work in practice, mock-ups and prototypes validate them instantly. A functional prototype also hypothetically validates a concept and how well it works in a real situation.

## **Evaluating concepts**

The predecessor of the final concept was represented by prototypes constructed in polyurethane based foam and tested by the reference group in machines. Different methods was used to evaluate the prototypes in order validate the concept. The prototypes were built to facilitate existing technical products to fully function as a functional prototype.

To evaluate a concept, a physical prototype is an effective method. By evaluating concepts in a situation, as close to a real end-user situation as possible, the validity of the evaluation gets higher.

## **Final concept**

A new functional prototype was made of high-density foam of polyurethane that represents the final concept. The technical functionality was nearly as high as the previously tested in wheel loader. The same joystick base was used and rocker switches was mounted etc. The input from the thorough evaluation was taken in and changes were made to the final concept.

Projects output is best communicated with a physical prototype. A final prototype validates the concept, and validate if the project has reached the goals set in the start of thee project. The prototype is able to use in further developments and machine testes if wanted.



# 6 Analysis

*This chapter contains a deeper analysis of the human-machine system, the users and the tasks in order to understand how wheel loader tasks affect the user. A physical ergonomic analysis was performed, using an anthropometric analysis, ergonomic simulation and subjective analysis, to analyze the current linear control levers and to find a basis of recommendations to use when designing the single lever. A cognitive ergonomics analysis was performed to get a deeper understanding of the context of wheel loader usage, defining the human senses and multimodality and analyze the mental model of machine operators.*

## 6.1 Human-machine system description

The wheel loader and operator are most often a part of a team that interacts with other parts. These parts, or components, are working together to accomplish a common goal. This is in line of the system theory (*chapter 3.2.3*). Therefore a system description is used as graphical instrument in this project, to summon the important system boundaries, the components and the communication between included elements.

### **The wheel loader and the human**

The reason wheel loaders exist is to perform a main process and fulfill a certain goal. In this case that is regarded to be excavating, and transferring of, rather heavy matter. This is only possible when a human operator interact with the wheel loader, makes decisions, communicates with co-users and also the opposite; this is only possible for the human by using the machine.

The wheel loader and human operate in an environment, that exists outside the drawn system boundaries (Sanders & McCormick, 1993), (*figure 6.1*). As the environment only shares relations of input and output with the system, the system in this case is defined as an Open System according to Flood & Carson (1993). The environment is, in a common application, the world outside a gravel pit business. This outer part of the system described is the work organization with staff management that commands tasks to be performed. The narrower system of interest where the human interacts with a machine is the users work situation in the wheel loader. The operator is essentially in control of all available functions of the wheel loader, can be considered a Mechanical System (Sanders & McCormick, 1993).

The user receives a task or order to be performed from the staff management. Often the user communicates with a co-user by audial or visual means and uses instruments and controls in the machine to perform the task. The physical barrier and interface are the windshield and the instrument panel for visual information, audial communication equipment, the control levers for controlling hydraulic functions, and various buttons among other things that the user needs for perceiving and acting in the situation. The user's body will also receive and percept information through the machine itself, carried by vibrations and sound.

### **Conclusion system description**

Commonly there are physical factors that affect or interfere the operator's use performance and relation to the control levers and other interface. Such factors can be large full body vibrations disrupting e.g. the visual perception and affects the motoric control. Sitting in a seat for long working sessions, and the frequent use of joystick or levers, cause static workload.

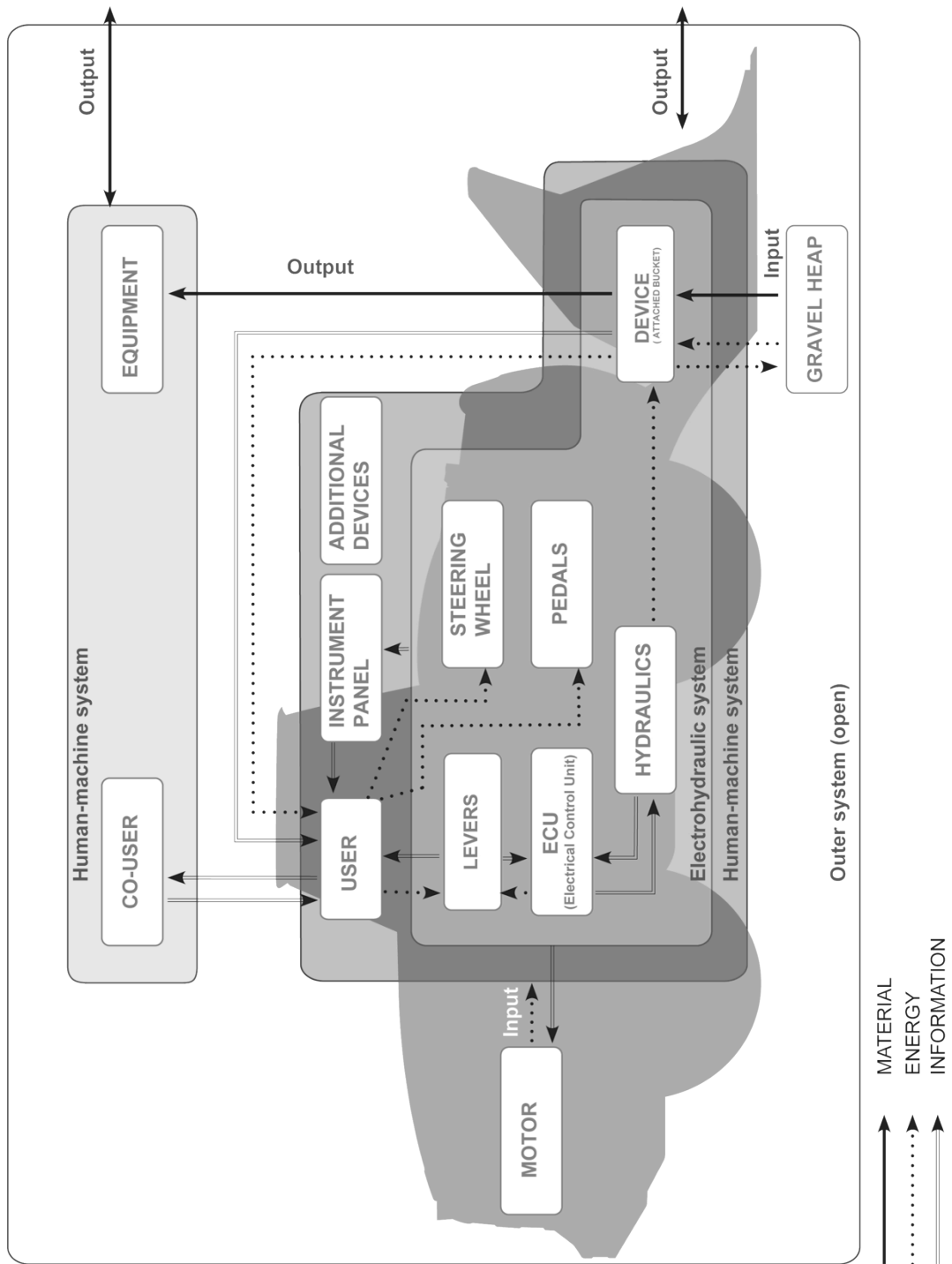

Figure 6.1 the system description.

The user controls the machine with levers, pedals and steering wheel. Information is visually received through the windshield and instrument panels, but also tactile through the levers and other contact surfaces.

## 6.2 Wheel loader operators and task

### 6.2.1 User Profile of machine operators

The purpose of the User Profile (*chapter 4.2.6*) was to understand the operator's prerequisites and to find user characteristics. To gather information about the operators, semi-structured interviews (*chapter 4.1.3*) were made with a salesman from Volvo CE's dealer Swecon in Gothenburg, a repairman and previous machine operator at Vikans Kross and with machine operators from Per E Person Transport AB in Borås, Stig Gustavsson Maskin AB in Borås and Niclas Entreprenad AB in Torslanda.

#### **Background**

The primary user of a wheel loader is the machine operator. The majority (98%) of the Swedish machine operators are men. However, the amount of female machine operators has been steadily increasing during the past years. The age of the machine operators vary from 20 years old to age of retirement, the majority of the operators are middle aged. At Vikans Kross the machine operators are from 35 years old and upward. A machine operator education is required to operate the machines. In order to apply for the education an elementary school degree and a driver's license of type B is needed (Arbetsförmedlingen, 2011).

#### **Usage**

The operators often work long hours. In Sweden the work hours are controlled by federation of labor union to a maximum of 48 hours a week including overtime. (Seko, 2011) A regular workday consists of 8 hours of work where the operator has a morning, lunch and afternoon break. The operator often works 2-3 hours at a time in the machines.

The operator needs to have good knowledge about the machine. The operators must probably read the instruction manual in order to use the full potential of the machine or at least perform a trial and error period. When operating the machine there is a close interaction between the operator, machine, task and environment. An operator that uses the same machine can have different attachment to the machine, which makes it important that he/she learns to use the machine in various ways. The operator has to learn how to operate the machine and has to practice in order to become good at it. It can take several years to learn how to find a good balance between the functions of the machine, tasks and different environments.

For the employer it is important that the operator has experience. According to Billman<sup>3</sup>, a more experienced operator work more efficient and economically. E.g. when an experienced operator operates the machine they manage to consume less fuel than a new

---

<sup>3</sup> Göran Hägg, Professor, KTH, verbal contact (mail) 27<sup>th</sup> of September 2011

<sup>3</sup> Ralf Rosenberg, Designer Msd,

machine operator. Because of this, the machine operators are valuable assets. If the employer hires a new machine operator that has to be trained from scratch this would be an investment for several years ahead.

### **Influence and responsibility**

In Sweden the machine operator often have a personal machine only he/she uses. How much the operator can influence the specifications of the machines depends on the employer. Often the operator choose e.g. a specific seat and what hydraulic connectors the machine should be equipped with. According to Widberg<sup>4</sup> the operators participates and influence the ordering of the machines in 50% of the cases.

One single operator has the full control of the machine. The environment around wheel loaders is mostly solitary ground or is behind fenced areas. Therefore it does not exist any mayor interactions with other users or machines within the human-machine system. Most communication with co-users is made using cell phone or short wave radio.

Generally a machine operator is put under a lot of pressure. The employer demands good results with a high efficiency. Since the workload can differ, the machine operator has to be prepared to work overtime with a short notice. Most commonly the operators are given a task that should be performed, and they decide themselves how to perform the task the best way. In many workplaces the time of executing the task depends on other people. E.g. when loading a dump truck with gravel, the machine operator has to adapt to when the truck arrives and must leave. This can lead to a varying workload that some days or weeks are more demanding.

### **Emotional relationship**

The wheel loaders studied in this project are large machines owned by companies or the municipality. Individuals can also own wheel loaders for private use but then they often use smaller machines or are self-employed with a smaller contractor business. It is often the companies that own the machines but as mentioned earlier, the machines are often personal. The users may therefore develop an emotional relation to their machines. The machines of the interviewed operators had the operator's name and phone number visible on the outside of the machine. The inside of the machines were decorated with personal photos and items. One of the operators even had a Persian carpet in the cabin.

### **Discussion User Profile**

Since a Swedish machine operator has to be educated to have it as a profession the term novice operator get a slightly different meaning. A novice operator in this context do not necessary have to be unfamiliar with the machine, rather an operator that has limited experience but still knows the basic functions of the machine. There is clearly a difference between novice operators and experienced operators which can be seen in the performance, through the effectiveness and execution of tasks, in a long term perspective it can be seen in the wear and tear of the machine and the amount of fuel consumption.

---



The amount of continuous working hours shows that there is a high risk for static workload especially during high seasons where a lot of work has to be done and the operators might not have time to take breaks in their work.

The fact that the operators often have personal machines is an advantage because it minimizes the effort the operators have to put into finding the right adjustments for the sitting posture, which makes it more likely that they actually will try to improve their sitting posture. In theory they only have to make the major adjustments to the chair and armrest once and thereafter only make minor changes if they experience discomforts.

### **Conclusion User Profile**

Because of the machine operator education the control levers do not necessarily have to be easily maneuvered for a first time user. The goal of the levers being easy to use for a novice operator is rather directed towards shorten the learning time of achieving a high level of precision than being able to manage a high level of precision after the first attempt of trying.

The risk for static workload can be reduced if the control levers enable a variation of grip. If enabling grip variations, different muscle group can be used in the hand and forearm, which would provide micro breaks for the muscles not in use at the moment. The ability to easily adjust the chair and the armrest is not a primary issue if operators only have to do it once if using personal machines.

## 6.2.2 Analysis of wheel loader task

For understanding what is required by the user to fulfill common tasks, a Heuristic Task Analysis (HTA) (*chapter 4.2.3*) was performed. The main purpose of the HTA was to identify the lever operations required by operators to performing common tasks. Another purpose with the method was to find situations where the user must operate several levers simultaneously. Tasks were analyzed heuristically by video recordings, observation (*chapter 6.2.3*) and via descriptions from an instruction manual (Volvo CE customer Support 2009). In the analysis following tasks were chosen that implements two to four hydraulic functions:

1. Excavating gravel
2. Loading gravel onto truck
3. Using pallet forks
4. Picking timber logs from truck.
5. Loading timber into stacks
6. Loading timber onto truck

### **Result Task analysis**

One HTA are here visualizing the method and the result (*figure 6.2*). The rest of the HTA analysis can be seen in *Appendix I*. Controlling wheel loader attachment demands simultaneous use of several levers. Absolutely most frequent is *lift* and *tilt* used simultaneously, but also the third and fourth must be used in a lot of combinations with each other. Other sub-goals are presented as done in sequence, but in practice the operators seem to perform very few of these single sequential sub-goals. The operators hold their hands on the levers the short moments they are not in use. Operators do not seem to look at the linear levers at any time, only looking out the windscreen.

Gravel excavating does not involve very precise operations of the bucket, but other work as planning work does. Any time the operator is working with co-users, the machine must be handled with caution, as the power of the machine potentially can damage a lot of things in the surroundings, for instance when loading timber.

The attachment and load it carries often obstruct the visual field for the operator: the operator does not see behind the load.

### **Discussion Task analysis**

The work requires skills of the operator to maneuverer the levers without looking at them so the operation is performed with high-automated cognitive processes that requires training to perform. Several tasks are also performed without direct visual information of the area of the action, and instead, tactile senses and hearing is used instead – for instance: when loading timber on a truck the contact area between the grappler and the truck is invisible and the task must be done with care.

The HTA does not reveal any clear sequence of doing task; the method is too coarse for this. The tasks thereby seem to demand focus foremost for parallel work.

### **Conclusion Task analysis**

The method revealed several difficulties for the user; simultaneous use of levers while also driving the vehicle, and also the precision demands are noticed. Even if not more than one levers is maneuvered at one point, the user almost certain instead drives the vehicle. So, no future product can be designed to rely on the user having any break, or be

free from using the levers during operation. As any combination of the four functions seems to be present, the future product should provide an integration of the functions. If no such solution can be obtained, at least the design should not induce any major adjustment of the hand posture for this kind of simultaneous use.

A prioritization between the functions can be concluded from the HTA; the primer functions of *lift* and *tilt* must be prioritized and due to this the design might be optimized for these two. Then the third and fourth function can be made as modules that can be added on customer demand, but they should not inflict on the primer functions. A last remark is that the use of the third, or fourth function should be easy to use together with first and second function. This should give an aim for the future product development to reduce demands of large hand movements and a lot of different hand postures for each user.

The frequent use of the levers also induces a need for the future product to also facilitate a break or support for the hand.

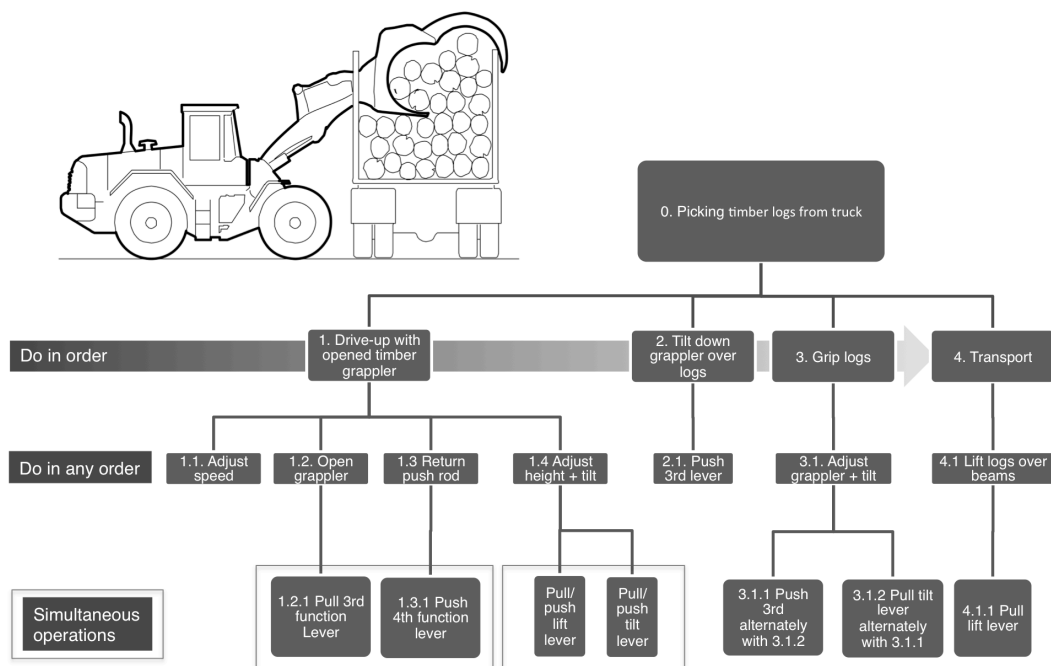

Figure 6.2. HTA of picking the timber from a truck

The first challenge for the user is the combined use of the lift and tilt levers to place the attachment correct in height and tilt (Sub-goal 1.4). Full lever actions forward for the tilt, and full lift backwards, requires maximum finger spread and wrist deviation. The user must perform the gripping task (Task 3) more or less independent from visual intake as the grapple is hidden behind the logs. At this moment the tilt and third function levers must be alternately manipulated to grip the logs and the user can potentially damage the truck (3.1.1 and 3.1.2). The cognitive workload increases at this moment as the user must rely on tactile input from the machine and attachment and then manoeuvre the attachment exact and quickly (Volvo CE Customer Support, 2009 P. 143; Volvo CE, 2011).

### 6.2.3 Observation study

The purpose of the observations (*chapter 4.1.1*) was to analyze the hand postures when operating the machine. Three operators were studied operating their personal machines. The machine models used was one L70F, one L90F and one L120F. The L70F and L90F were equipped with a forklift and the L120F was first equipped with a regular bucket and then changed into a snowplow. The observation took place in Borås, (L70F and L120F), and at Torsland, Gothenburg (L90F) on the 14<sup>th</sup> of September 2011. Users were studied and filmed from the outside and the inside.

A camera was placed on the right side window of the cabin, facing down to record the movement of the right hand. A separate camera was used outside the machine to record the machine moving. All machines had an older type of levers, the servo-assisted hydraulic levers, that is basic equipment for the F-series and also another armrest than is used in the G-series machines. The physical form of these levers is not identical as in the G-series, but the functionality and form is analogue (*chapter 2.1*) and is considered adequate for the observation. To differentiate between the participants and keep them anonymous, the participants will hereafter be referred to the operator of respective machine model.

#### Result observation study

The postures from using *lift* and *tilt* and from using 3<sup>rd</sup> and 4<sup>th</sup> *function* were analyzed. Screen shots from the observation recordings are used to visualize the findings. The tasks performed during the observation were changing of attachment, pallet fork work, planning work and snowplowing. The position, where the forearm is pronated, have been defined as the position where the hand is placed in a comfortable way when the levers is not in use (*figure 6.3*). The operators have the hand resting on the levers for support and to feel the levers as to be ready whenever they need to use them. The hand positions seen in the study is close to the neutral position of the hand.

Here it can be seen that all operators have their hand in approximately 45° from the bodies middle axis, in the transvers plane. This is due to the armrest being fixed in position relative to the levers, and the levers being placed to the right side of the body. Two alternate consequences of this angeling can occur. Firstly, the operator has to tilt their wrist (up to 45°) in a radial deviation in order to control the levers. Secondly, the operator moves the upper arm away from the body in order to place the lower arm and wrist linear with the levers. Both of these postures will create an unnatural working position.

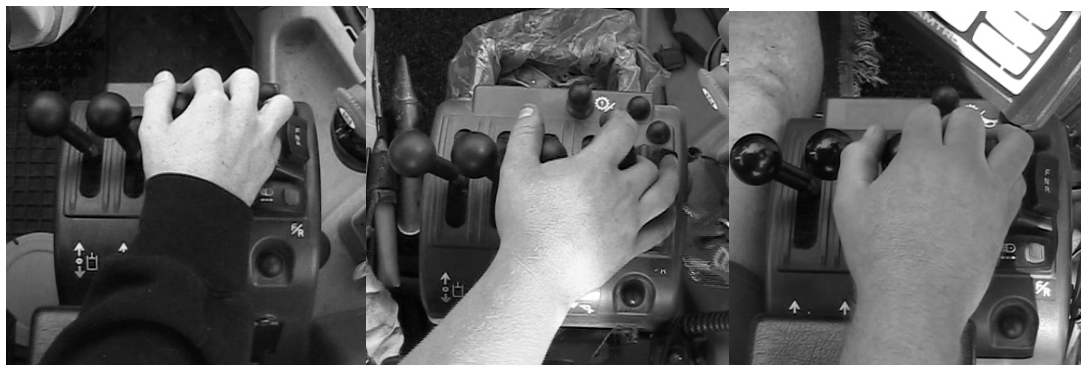

Figure 6.3 The observation participants, from left: L70F, L90F and L120F

### Working postures of L70F

Then changing attachment the operator of the L70F uses the thumb and index finger to control the *tilt* lever. With his middle finger and ring finger he controls the *lift* lever, see left image (figure 6.4). He does not deviate the wrist to any large extent, either ulnar or radial. The fingers is flexed and extended to perform the task. When doing pallet fork work he changes the grip of the *lift* lever to the ring finger and little finger when using the 3<sup>rd</sup> function with his thumb and index finger, see left image (figure 6.5). During this operation the fingers are stretch out to an unnatural position also causing the gripping force of the fingers to decrease.



Figure 6.4 working postures of L70F when using 1<sup>st</sup> and 2<sup>nd</sup> function (Changing attachments)



Figure 6.5 working postures of L70F when using 1<sup>st</sup> and 2<sup>nd</sup> and 3<sup>rd</sup> function (Pallet fork work)

## Working postures of L90F

The operator of the L90 controls the *tilt* lever solely with his thumb and the *lift* lever with his index finger and the middle finger with extension to produce force. A great radial deviation of the wrist in can be seen when he pulls the *tilt* lever towards himself, left image (*figure 6.6*). When doing pallet fork work he uses his thumb to push the 3<sup>rd</sup> *function* lever and the index finger to pull the lever towards him. He changes the grip when only using the *lift* and *tilt* lever, so that the thumb controls the *tilt* lever and the index finger and middle finger controls the *lift* lever (right image in *figure 6.7*). During this operation the thumb and index finger are stretched out which gives a decreased strength in the thumb. The use of the little finger in the left image reveals yet another stretched posture and use of weak muscles.

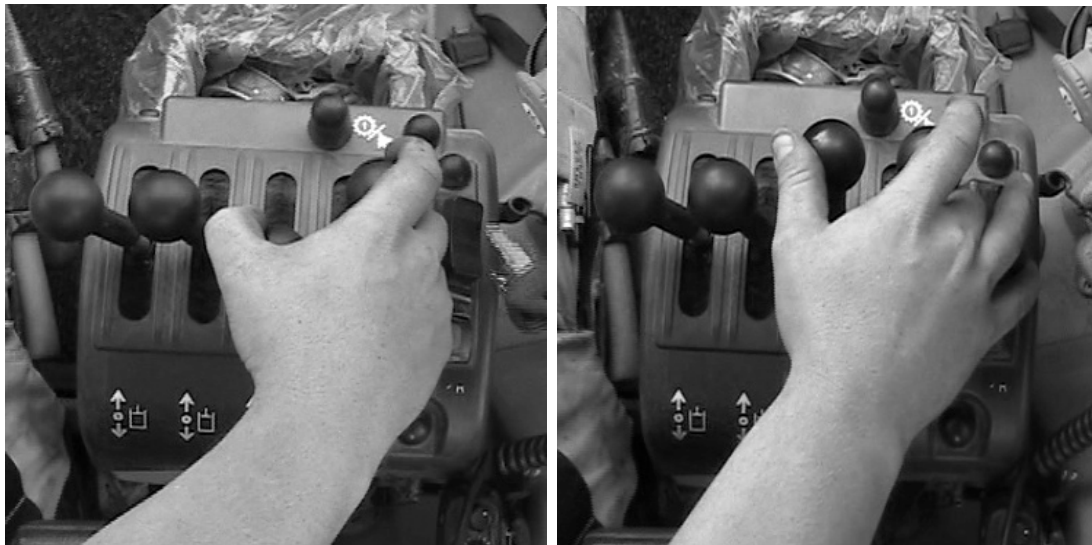

*Figure 6.6 working postures of L90F when using 1<sup>st</sup> and 2<sup>nd</sup> function (Changing attachment)*

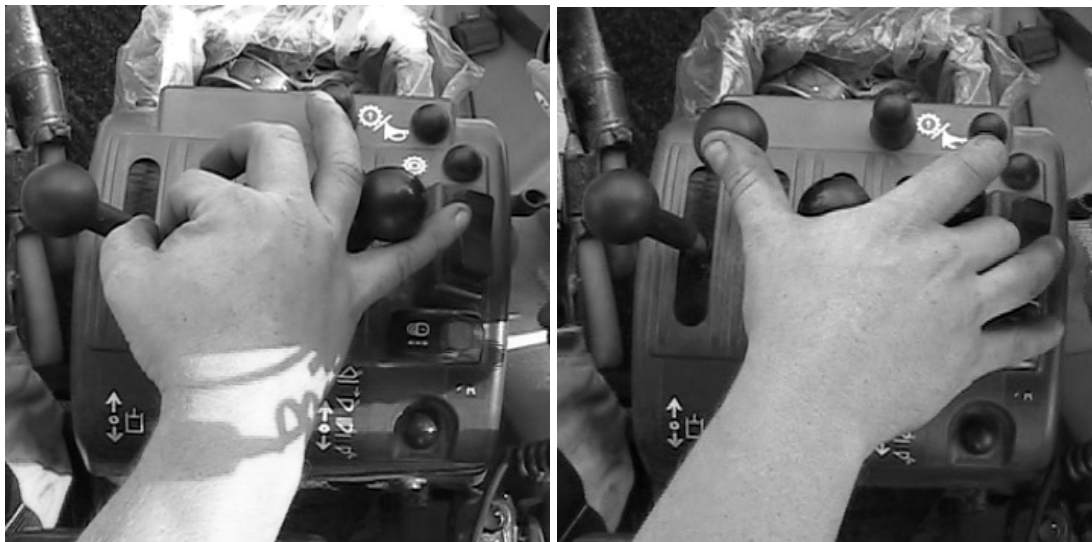

*Figure 6.7 working postures of L90F when using 1<sup>st</sup> and 2<sup>nd</sup> and 3<sup>rd</sup> function (Pallet fork work)*



### Working postures of L120F

The operator of the L120F uses the thumb and index finger to control the *tilt* lever and uses the ring and little finger to control the *lift* lever. The hand and wrist does not change position that much more than a slight radial deviation of the wrist, see right image (*figure 6.8*). When doing snowplowing work he has three different grip positions, either on the 3<sup>rd</sup> function and 4<sup>th</sup> function lever, the *lift* and *tilt* lever (*figure 6.9*) or on all four levers. The two first grip positions (Left image in *figure 6.9* and left image in *figure 6.8*) require that the operator change the grip more frequently than when gripping on all four levers. But, that posture makes the operator to stretch the thumb and little finger resulting in a weakened grip.



*Figure 6.8 working postures of L120F when using 1<sup>st</sup> and 2<sup>nd</sup> function (Planning work)*



*Figure 6.9 working postures of L120F when using all four functions (Snowplow work)*

### **Discussion observation study**

The finger and hand posture patterns are highly individual, many and complex. Every user had developed individual patterns and postures. When only using the *lift* and *tilt* functions the hand can mostly obtain a natural position. Problems do occur when the operator pushes one of the levers to one extreme end position and at the same time pulls the other lever to the opposite extreme end position. In order to perform this operation the operator has to twist the hand into an unnatural position and extend some of the fingers.

When using more than two functions more problems were revealed. An operator with a smaller hand such as the operator of the L70F machine can barely reach three levers at the same time. For him it would not be possible to reach the fourth lever without changing the grip. For someone with a larger hand such as the operator of the L120F is possible to reach all four levers but in the process, the hand is stretched out in an unnatural position. The placement of the controls in the transverse plane, to the right of the user cause the user to extend the arm from the body.

These tasks are also performed without looking at the levers; the user has to focus on the outside, as he must perform the tasks while also driving the vehicle. This is in difference to any other similar work conditions: forestry machines, excavators and similar machines are used while being stationary. The observation also revealed users gently resting their hands on the levers when not using them. So, even if they did not use the levers, they have contact with the levers, but cannot fully rest the hand as this would cause unintentional manoeuvring if the machine starts to shake.

### **Conclusion observation study**

In combination with the previously described HTA studying the tasks and operations a vital conclusion could be made; it is the combination of the hand movements, the patterns of hand postures and the duration of them that determines the ergonomic effect. This conclusion creates a basis for choosing other ergonomic methods; the study cannot present one “snap shot” of the reality, hence no method relying on this basis can be used. The HTA revealed a lot of simultaneous use of several levers. This means a lot of the awkward hand postures described in the observation, are frequently occurring.

The great distance between the levers causes obvious ergonomic issues, even though these particular postures cannot be ergonomically analysed due to the combinations of hand postures and dynamic characteristics. The user must either stretch their fingers or change grip to use more levers than two. The levers have changed the form in the succeeding machines, but the distances between them are at least the same.

This is part of the problem to solve, the user should not be forced to stretch, nor change grip to use the hydraulic functions available. All users also show individual postures that also are alternated in different situations. These varieties and individual comfort preferences should be acknowledged and addressed in the future product development.



## 6.3 Physical ergonomics in wheel loaders

### 6.3.1 Ergonomic simulation of work postures

Ergonomic simulations in a virtual environment is a good way to analyze products and situations without having to construct costly models and do time consuming evaluations involving calculations and interviews. By analyzing virtual representations of human models and products, forces and postures can be evaluated numerically and cheaper than building full size models. In this project the purpose of the ergonomic simulation was to find a work posture with as high comfort scoring as possible.

For the evaluation of the hand using control levers Jack (Version 6.1) was used (*chapter 4.2.4*). A mannequin representing the 50<sup>th</sup> percentile human was placed in the seat together with the armrest and control unit. By analyzing current postures to manipulate the levers (taken from the observations in the previous chapter), and then replicating them in the software they are assessed and given a comfort score depending on arm, hand and wrist alignment. This score represents how comfortable the different hand and arm postures are. Due to the sheer amount of postures possible and the programs inability to access finger comfort, one of the worst postures was chosen as subject of the analysis (*figure 6.10*). Here the operator grasps the second and third lever while controlling the fourth with the little finger (the mannequin's left arm is set to mirror the right to make the piles over the angle value a bit more easy to show). A posture that would give best scores was then used to have as a guideline on how the armrest and control unit should be placed to incorporate good comfort while operating the controls (*figure 6.11*).

#### **Result Ergonomic simulation**

The posture scored especially bad in radial deviation of the wrist, upper arm elevation and humeral rotation. The hand also has a very deviated angle as well as little flexion (*figure 6.10*).

#### **Conclusion Ergonomic simulation**

The results can be aggregated into a conclusion that the existing design is not fully ergonomically satisfying. The simulation reveals that ideal comfort angles are reached if the hand is placed close to the knee and the hand in a small angle from the horizontal plane. In addition, with the hand close to its neutral position by a better fore arm twist, it would be easier to facilitate better comfort as well as easier to allow the muscles to rest more frequently, without having to change posture. This in the long run would benefit many users and perhaps lower pain associated with this work. Even though many other aspects such as forearm twist and elbow inclination scored well when using the linear control levers, the conclusion would be that the posture analyzed would not be acceptable for long hours with high repetition of movement and precision requirements.

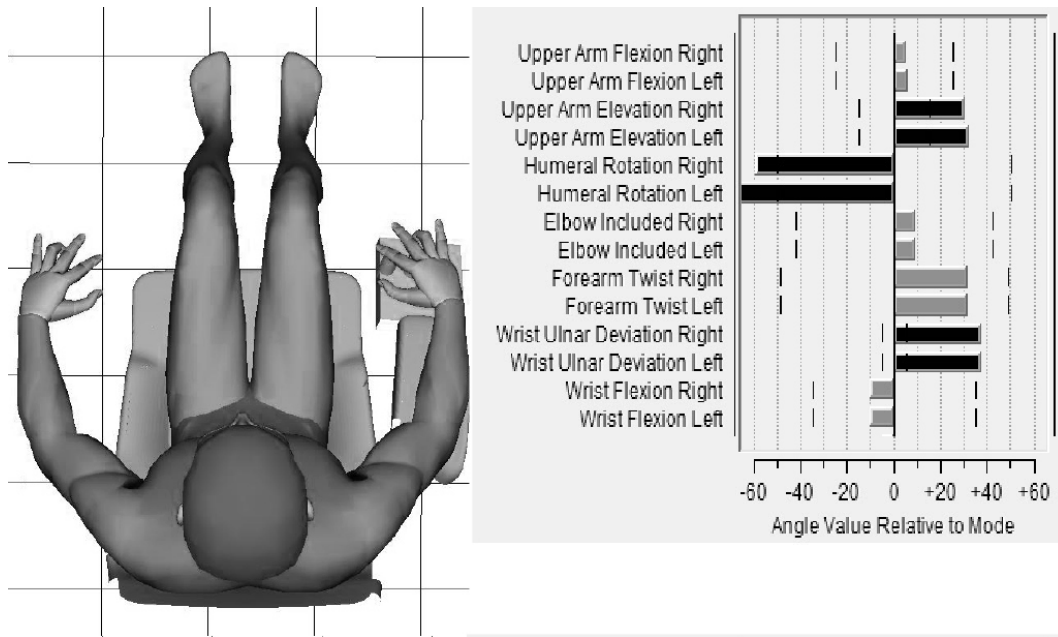

Figure 6.10 Jack simulation - Bad working posture taken from the observations.

The control unit and armrest are adjusted within the normal adjustment range. The darker piles from the analysis tool in the software represent joint angles that are not recommended and regarded discomfoting.

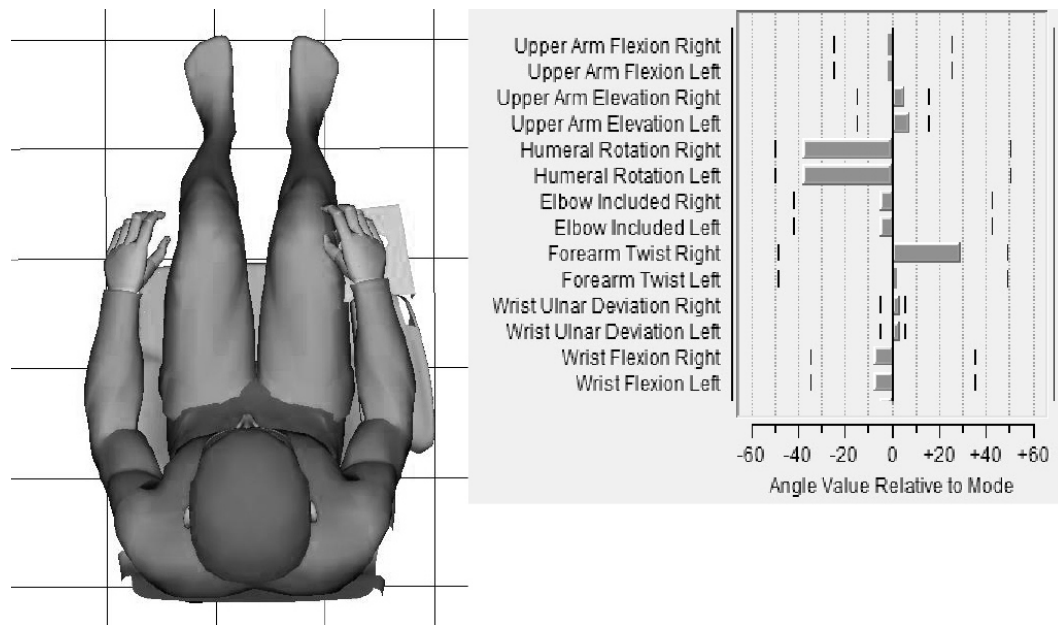

Figure 6.11 Jack simulation – Good working posture

By adjusting the mannequin into a posture (as good as possible considering the work situation), actually sets the variables within acceptable levels. Several joints get close to their neutral position and operating within these parameters for long hours would be a lot better than the posture analysed.

### 6.3.2 Anthropometric analysis

An anthropometric analysis was performed to gather important anthropometric measurements (*chapter 4.2.1*). The goal was to find the most appropriate dimensions for feature that needs to be used in a new design. Since Volvo CE sells their wheel loaders on a global market the 5<sup>th</sup> to 95<sup>th</sup> percentile of Chinese, Japanese, EU and US populations generally need to be considered when addressing a global population (According to Piamonte<sup>5</sup>). The gathered anthropometric variation was then visualized using Jack version 6.1 (*chapter 4.2.4*).

Table 6.1. Measurements of importance in lever design. All measurements are in mm.

Anthropometric measurements of the hand					
<b>Hand breadth without thumb</b>					
	Country	5 <sup>th</sup> %ile Female	50 <sup>th</sup> %ile Male	95 <sup>th</sup> %ile Male	Source
	China	65,9	82,8	90,8	PeopleSize 1998
	Germany	72	85	93	DIN 1986
	USA	70,2	87,4	95,4	PeopleSize 1998
<b>Hand breadth with thumb</b>					
	Country	5 <sup>th</sup> %ile Female	50 <sup>th</sup> %ile Male	95 <sup>th</sup> %ile Male	Source
	China	80,2	102,8	112,9	PeopleSize 1998
	Germany	82	107	116	DIN 1986
	USA	82,3	107,1	116,7	PeopleSize 1998
<b>Hand circumference, grip (measured by grasping a cone at the largest circumference permitting the tips of thumb and middle finger to touch.)(no males was measured).</b>					
	Country	5 <sup>th</sup> %ile Female	50 <sup>th</sup> %ile Male	95 <sup>th</sup> %ile Male	Source
	Japan	38,5	41,8 (female)	44,7 (Female)	PeopleSize 1998
	UK	40,2	48,4	55,4	PeopleSize 1998
	USA	39,9	48,6	55,6	PeopleSize 1998
<b>Middle finger length</b>					
	Country	5 <sup>th</sup> %ile Female	50 <sup>th</sup> %ile Male	95 <sup>th</sup> %ile Male	Source
	China	70,5	80.08.00	88.08.00	PeopleSize 1998
	Germany	69	83	92	DIN 1996
	USA	68.08.00	84.04.00	93.04.00	PeopleSize 1998
<b>Hand length</b>					
	Country	5 <sup>th</sup> %ile Female	50 <sup>th</sup> %ile Male	95 <sup>th</sup> %ile Male	Source
	China	156,8	183,4	198,7	PeopleSize 1998
	Germany	159	186	201	DIN 1986
	USA	158,3	190,3	206,8	PeopleSize 1998
<b>Thumb breadth (measured across the broadest part of the thumb joint)</b>					
	Country	5 <sup>th</sup> %ile Female	50 <sup>th</sup> %ile Male	95 <sup>th</sup> %ile Male	Source
	China	n/a	n/a	n/a	n/a
	Germany	16	23	25	DIN 1996
	USA	18,5	20,2	22,7	PeopleSize 1998
<b>Index finger length</b>					
	Country	5 <sup>th</sup> %ile Female	50 <sup>th</sup> %ile Male	95 <sup>th</sup> %ile Male	Source
	China	61,9	71,4	78,5	PeopleSize 1998
	Germany	62	75	83	DIN 1996
	USA	61.06.00	75,7	84	PeopleSize 1998

<sup>5</sup> Dominic Paul T. Piamonte, MD, PhD, Eur.Erg., Human Factors & Ergonomics Specialist, Volvo Group Trucks Technology, interviewed September 13<sup>th</sup> 2011 and October 20<sup>th</sup> 2011

## Result anthropometric analysis

The hand measurements can be seen in *Table.6.1*. Data are gathered from Peebles & Norris (1998) and the specific source is shown in the table. Hand length and width are used to determine reach and sizes. For fixed sizes of handles, for resting support or lever maneuvering, the praxis are that the 50<sup>th</sup> percentile human hand dimensions are used for the design, according to Piamonte. The circumference and finger length are used to determine size of the lever grip and the stroke of the lever. Especially the gripping circumference is widely different between the 5<sup>th</sup> and 95<sup>th</sup> percentile – up to 44% larger for the 95<sup>th</sup> percentile male. Also the hand breadth differs from about 80 to 117 mm (a 45% difference from 80,2 mm). To visualize the anthropometric variation of the spatial reach and comfortable sitting postures the manikins were placed with the arms in the good working posture regarding comfort angles for the hands (*chapter 6.3.1*), and then the 5<sup>th</sup>, 50<sup>th</sup> and 95<sup>th</sup> percentile manikin was super positioned with the same angles (*figure 6.12 and figure 6.13*). The software constructed 5<sup>th</sup>, 50<sup>th</sup> and 95<sup>th</sup> percentile manikins, based on populations from the integrated database:

1. Chinese woman as 5<sup>th</sup> percentile
2. German male as the 50<sup>th</sup> percentile
3. American male as the 95<sup>th</sup> percentile.

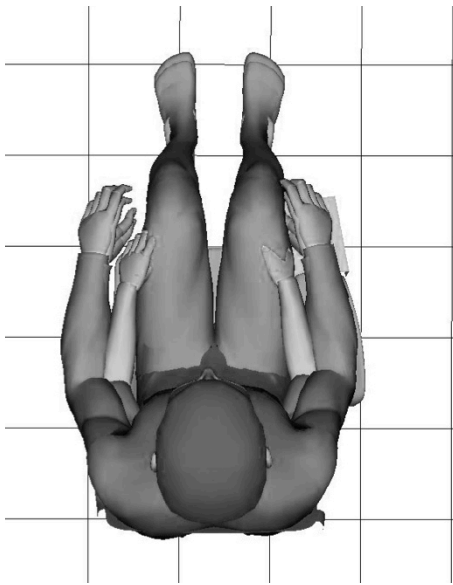

*Figure 6.12 Jack simulation from above  
Hand position in ideal comfort hand angles*

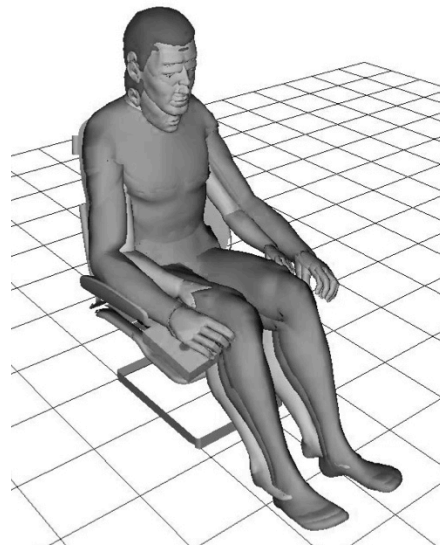

*Figure 6.13 Jack simulation  
Notice the positions the levers must be adjustable to fit smaller sized people.*

## Conclusion anthropometric analysis

If a new design concept should aim for a lever of greater size, for example a joystick, grip circumference would become more important to accommodate the diameter of the lever to fit the hand. Handbreadth with, and without, thumb is important when designing a hand support or handle. The users' anthropometric variation requires big adjustment abilities of the control units.

### 6.3.3 Subjective analysis of machine operators

During the observations, semi-structured interviews aided by questionnaires (*chapter 4.1.2 and 4.1.3*) were made that based ground for collecting subjective opinions from the operators of their ergonomic situation. As the workload and ergonomics depend on more factors than biomechanical a method were developed within this project in order to analyze the perceived exertion: in a study made by Adolfsson et al (2004) the authors examined the joint angles with goniometers and in addition, analyzed users subjective perception with a questionnaire. This questionnaire was adopted in this project as it angles the study to the long terms effects, and also made it possible to define questions specifically regarding the levers (*Appendix II*). For every question the user answered, the user came closer and closer towards rating discomforts and subjective perception regarding the lever itself. When the question regarded the armrest, their opinions got more and more disparate. Five wheel loader operators were available to answer the questionnaires. The work experience ranged from three to seventeen years, and the participants' age ranged from 26 to 42 years. Complementing semi-structural interviews (*chapter 4.1.3*), were made to enhance the qualitative value of the analysis.

#### Result subjective analysis

Volvo is regarded as the best wheel loader brand when it comes to cabin comfort. The users are in general pleased with the levers but one of the interviewed do have serious problems and a diagnosed injury in the tendons and/or joints in the base of the 2<sup>nd</sup> and 3<sup>rd</sup> finger. This is undisputedly related to the levers but this user has been working with these machines since the 80's, and today's levers presumably only awake the injuries developed from older machines.

The users are seated for 2-3 hours at the time in bigger machines. In smaller machines they are in and out a bit more often and the biggest ergonomic discomforting factors can be related to the system surrounding the user. Big vibrations and long hours in the machines lead to different discomforts such as stiffness in upper body and back pain. Mental tiredness occurs due to high cognitive workload and to some extend sound levels.

As most users have their personal machines, frequent adjustment of the controls is unnecessary. There is however a broad understanding of the importance of a correctly adjusted seat and work posture. Although there is a latent need of improvements to the armrests' and the levers' adjustability as the levers sometimes are adjusted in the workshop as soon as the loader is delivered.

*Table 6.2* shows an interpreted summary of the affected body parts withdrawn from the questionnaires, interviews and observations. Ranges of discomforts are added from the data withdrawn from the questionnaire.

*Table 6.2 Effected body parts*

Perceived discomforts			
Body part	Discomfort ranging from	Discomfort ranging to	Minimum time span to perceived discomfort
Back and upper body	Stiffness	Light pain	After a week's work
Forearm and wrist	Light discomfort	Moderate pain	After a day's work
Hand and finger postures	Light discomfort	Somewhat strong pain	After a day's work to years of work

## 6.4 Cognitive ergonomics in wheel loaders

### 6.4.1 Machine operator's perception and senses

When operating a wheel loader the vision is the primary sense. Without the vision the machine cannot be operated. The vision is mostly used to interpret the placement of the machine and the position of the bucket, for reading the gauges on the instrument panel and for keeping attention so that the operator does not crash or run in to something. The vision is also used to interpret communication from clients or co-workers outside of the machine.

There are some visual limitations for a machine operator. The operator is seated in the cabin on top of the machine – where the machine obscures parts of the visual field. From the operator's placement it can also be hard to interpret the position of the bucket. The operator can only see the back of the bucket and not the inside and front edge – which makes it possible to see how much the bucket is lifted but harder to see how much the bucket is tilted. There is however one design cue on the bucket, helping the operator to see the amount of tilting – the upper edge on the sides of the bucket is parallel with the lower surface of the bucket (that is hidden in the field of sight). Other visual limitations that exist is the decreased light when it is dark outside for an operator that works evenings or nights – which puts a requirement on good lighting from the vehicle. Also reflections and strong lighting during daytime can have negative consequences –requiring the operator to buy solar control film to put up on the windows. Since the vision is critical for performing the work tasks the machine operator profession is not suitable for someone with decreased sight, such as myopic or other visual defects. Hyperopia that often affects people in middle age and older is however not a problem when operating a wheel loader since the eye focuses a couple of meters ahead.

The hearing is the secondary used sense. The sound from the engine is used to determine the rpm without having to look at the gauge on the instrument panel. The rpm is important when filling a bucket with gravel to get the right hydraulic pressure in the mechanical arms for the bucket. The sound of the bucket against the gravel complements the vision for the operator to determine bucket position. Hearing can be used to determine if something is wrong with the engine or transmission. It is also used to interpret communication through mobile phone and short way radio from others.

There are a lot of auditory impressions for a wheel loader operator, which requires the operator to filter the sounds in order to focus the attention correctly. The auditory feedback from the engine and bucket would probably not be focused on if the operator at the same time would get a message from the short way radio. This might not necessarily lead to any major interference in the task performance since the operator still has the visual interpretation to rely on. However, the audio from the short way radio can cause disturbance in the task performance if the current task requires a high mental effort and/or if the audio contains an instruction that contradicts the current task.

The sense of touch and balance shares the third place of used senses. Vibrations from the machine make it easier for the operator to perceive what is happening in the surrounding. When the operator lifts a bucket with gravel the center of gravity changes in the machine - making the machine rock – that can be perceived in the balance sense of the operator and haptic if the operator bumps in or out the seat. This perception can be interpreted as a warning for the operator to be more careful so that the machine does not tip over.

Another tactile perception when operating the machine is the resistance from the control levers. Older machines with servo-assisted hydraulic levers share the same circuit as the hydraulic pistons for the bucket – resulting in a higher oil pressure and resistance in the control levers when the hydraulic pistons are higher loaded. This perception can be used as a complement to the vision – making it easier for the operator to judge the distance between the bucket and the gravel pile, determine the quantity of load and can also help predicting if the bucket will get stuck in the pile. A tactile perception from the control levers in newer machines where electro-hydraulic control levers is used can unfortunately not be perceived since there is not a direct connection between the controls and the hydraulic pistons.

The visual perception should be focused on what happens outside of the machine – not inside of the machine; therefore it is important that the instruments and controls inside the machine can be perceived using other senses. If controls and instrument would require visual attention it is good if they can be placed close to the field of sight of the work task (e.g. close to the field of sight when looking at the bucket). When the visual perception is not enough e.g. when tilting the bucket it is good if the perception can be enhanced from multimodality senses, in this case would tactile perception be the most suitable for complementing the visual perception. A small amount of tactile perception exists in the servo-assisted hydraulic control levers.

Auditory perception is the best way of attracting the operator's attention, but as mentioned earlier it is important that operator is not overloaded with auditory perceptions. Even if the human brain has a fantastic capacity of distinguishing and prioritizing different sounds it is important that warning signs does not disappear in the rumbling of all other sounds.

It is not easy to operate a wheel loader, at least for a novice user. A lot of the decisions of which actions to perform has to be performed blindly where the operator visually cannot see a direct result from the performed action. When filling a bucket with gravel the bucket obscure the inside of the bucket – as mentioned earlier – making it hard to see how much gravel has been filled and how tilted the bucket is. If asking an experienced machine operator how he does when he fills a bucket with gravel he would answer that you have to start digging in to the pile with an initial speed and continue to revving the engine, working with the *lift* and *tilt* function until the whole bucket is filled. If asking the operator how to find the right amount of rpm, lifting and tilting for filling a bucket with gravel he would not be able to answer that question. He would probably say that that is something that he feels or just knows when operating the machine. If asking an operator how he knows when the bucket is filled he would probably give the same answer. This example shows that there exists a high level of top-down processing (*chapter 3.2.1*) in the perception when finding the balance between the *lift*, *tilt* and rpm. Meaning that the operator uses his knowledge and experience when processing the perception.

The perception can also be bottom-up processed meaning that the operator uses stimuli in the surrounding, such as the senses, to process the perception. The machine operator uses both top-down and bottom-up processing when perceiving information. Because of the experience and knowledge of the experienced operators they don't have to reflect as much on the meaning of the experienced stimuli and senses – they can interpret the stimulus and know what action to perform based on the circumstances. A novice operator may perceive the same stimulus an expert operator, however does the novice operator probably not know how to interpret the stimulus correctly in order to know what action to perform. This conclusion suggests that the previous assumption, of an expert operator using more of a top-down processing than a novice operator, is correct.

### **Discussion operators' perception and senses**

One interesting aspect worth investigating, that is outside this project's scope, would be whether the performance differs between a machine operator, that operates a machine by remote control, compared to an operator that controls the machine from the machine's cabin.

Other competitors have recently introduced remote controlled wheel loaders to the market and the machine trend is aiming towards automation. The remote controlled wheel loaders advantage is the possibility of optimizing the size since the machine does not have to house a cabin, which is especially important in mining industries. One disadvantage with the remote controlled wheel loaders is that the amount of senses used in the perception is reduced. The machine operator is provided with a reduced visual perception and does not get any tactile and balance perception. Investigating and comparing the remote-controlled and the regular machines could give a clue of how much the tactile and balance perception affects the operator's performance.

### **Conclusion operators' perception and senses**

A conclusion of the stimuli processing is that a novice operator could be more helped performing a task if perception is given from several senses that complements each other. This would strengthen the bottom-up processing – giving a better perception for a novice operator that has limited experience and knowledge. Several complementing senses can of course improve the experienced operators perception as well, however isn't it as necessary since the experienced operator uses his experience and knowledge to fill out the gaps in the sensory perception.

The ultimate tactile perception, for the tilting of the bucket, would be if the operator were given feedback from the electro-hydraulic control levers. Absolute positioning of the levers would help the operator to perceive the tilted angle of the bucket and forced feedback could help the operator to perceive the resistance and pressure that is required for the bucket to work through the pile (none of these features exists in today's machines).



## 6.4.2 Operators' mental model and expertise

The user's mental models (*chapter 3.2.2 Mental*) are of interest in this context as this representation explains the users performance and may direct issues with the interaction design of the levers. An expert is regarded as a user with a mental model that is efficiently working for the main goal, in this how fast the wheel loaders perform, and how precise they can operate. Observations with interviews according to the ACTA method (*chapter 4.2.2*), took place in two sites; one on a construction site and another at an excavating site in Torslanda, Gothenburg 5<sup>th</sup> of December 2011. Tasks chosen for analysis was Loading gravel on the excavating site, and Loading of safety equipment on the construction site (*figure 6.14 and 6.15*). At the visit, the operators' work schedule could not be interrupted and on-going tasks had to be used for analysis. On the construction site the researchers took place in the machine during the task of loading safety equipment onto a truck. This machine and operator do a lot of different work tasks during the day and is considered a service machine that work on demand. In the excavating site the wheel loaders have a more static work situation. They are excavating gravel or rocks on the site and carry the matter for loading on trucks or boats. In both cases the operators were interviewed both during the tasks and after, sitting down. Several tasks were observed during the day, in both sites providing the project with data. The method has fixed questions, but during the interview a lot of more opens questioning expanded the visit to also collecting data on the operators situation. At the excavating site both a current wheel loader operator was interviewed, but also another person participated with more experience of the work. Films were recorded from inside the machines, that later were used in the analysis.

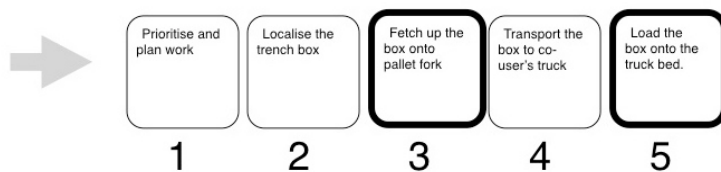

Figure 6.14 Task Diagram: "Loading safety equipment".

Most demanding sub-tasks were further analysed, marked by thick strokes and red colour. Fetching up the trench box required improvised use of the wheel loaders functionality. When loading the box onto the truck the user could foresee risks of damaging the truck.

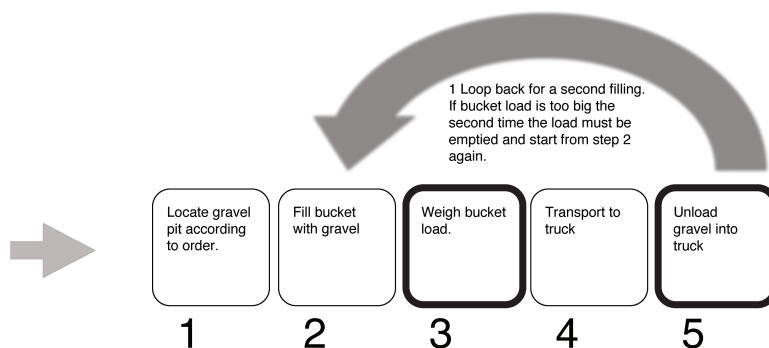

Figure 6.15 Task Diagram for "Fill bucket with gravel".

The weighing step is critical for the outcome of the effort in the task. The unloading part is demanding because of the contact with the co-user and the truck.

## Result of operators' mental model and expertise

The Knowledge audit was made on the demanding sub-tasks defined in the Task Diagram. First, an example was elicited where the users have had a clear understanding and then in analogue how the users assess the current situation. The chosen subtasks in the task diagrams were filmed and shown to the experts in order to interview them again using the Simulation interview technique from the ACTA method (Klein 1997), (figure 6.16). The data from the expert users is discussed in order to elicit expert knowledge and form a base to understand their work situation and later to form a description on their mental models. Selections from the interviews are shown in figure 6.17. For complete material from the Knowledge audit, see in *Appendix III* and from the Simulation interviews, see *Appendix IV*.

Table 6.3 sums up the user's mental model withdrawn from ACTA. Only Situation Level, down to the Process Level is of importance, as the structural level is not vital for the user when controlling the wheel loader. Answering the following questions for each level, performs the hierarchical abstraction model:

1. Situation – What is the main goal?
2. Task – what are the users task to achieve the goal?
3. Function – What can the system do?
4. Process – What happens within the system?
5. Structure – What does the system look like?

Knowledge audit – safety equipment  
Step from Task Diagram: Fetch the trench box with pallet forks

Example	Cues & strategies	Why difficult?
<p>Present and Future Yes, but no isolated example.</p> <p>The trench box is placed on other equipment in wet conditions, leaning down towards ditch.</p>	<p>Cues: The location and bad positioning means that someone else have left the box there.</p> <p>Strategies: Fetch the box with pallet forks and drag to flat ground. Box must be levelled up by smooth manoeuvring.</p>	<p>Machine itself is leaning. Hard to manoeuvre the big machine and foresee the movement of the fork tips.</p> <p>Novels doesn't reflect on the weather. The</p>
<p>The big picture</p> <p>Do what headman ordered, but the box will be used as safety equipment somewhere. Don't destroy the truck nor the box...</p>	<p>Cues: The box is in two pieces, not more, but user don't know where the box is sent to. Use a flat ground and always have good order.</p> <p>Strategies: Keep the pieces as they are as they are probably used in near future. otherwise they would have been dismantled in more pieces. minimise risk for damage.</p>	<p>Not expressed by the foreman who is suppose to use it or where it is heading. Hard for novels to understand where the structure is weak or strong. Not understanding the good effects of good order.</p>
<p>Noticing</p> <p>Yes, hitting emergency stop button because of a smoke that he spotted.</p> <p>Truck is not on site as the foreman sad.</p>	<p>Cues: Visually realised that truck is not there.</p> <p>Strategies: Get more information from the first source of information, the headman</p>	<p>Missing cues stated in elements above and maybe disbelieve if the location was right.</p>
<p>Job smarts</p> <p>Use the machine as much as possible instead of physical body work...</p>	<p>Cues: Recognise and find a flat and better ground.</p> <p>Strategies: Trust the manoeuvrability of the machine and use the fork tips to fetch the box and move the box towards flat ground. Always use a place that is flat.</p>	<p>Is not comfortable with expressing their requests for better conditions, such as fixed, flat places for storing equipments.</p>
<p>Opportunities improvising</p> <p>That occurs all day long, nothing is static.</p>	<p>Cues: Skewed placement.</p> <p>Strategies: use fork tips to move it closer and toward flat ground.</p>	<p>Hard to know if the structure is strong enough. Estimate the weight is sometimes hard, it is felt trough the levers and machine swing - haptic.</p>
<p>Self monitoring</p> <p>Sometimes, but often the job falls in routine.</p> <p>Small accidents have happened. For instance with a car. (Material damages only).</p>	<p>Cues: Feeling in levers and machine. Stress could be a cue.</p> <p>Strategies: Constant monitoring, but no specific instrument of following up performance. If damage is done some reflection is made of course.</p>	<p>Stress more easily, forgets importance of also do the job safe. Trying to please the headman.</p>

Figure 6.16 Resulting data sheet from the Knowledge Audit of the third step in the task of loading safety equipment.

On the third level "Noticing" the users had an example were he knew the situation by noticing smoke that others did not. In analogue to that, the probing reveals that he visually is missing a co-user in this situation and explains that novices in this situation have difficulties to do so.

Simulation interview  
Weigh bucket load

Event	Action	Situation assessment	Critical cues	Potential errors
Place bucket in correct height	Lift up bucket by pulling the lever.	Have correct height and not be in the heap.	Visually.	The scale may be less correct if in wrong position or in gravel heap.
Decide if the load is correct, too high or too low.	Push correct set of buttons. Read the figures.	There is material enough for the client or; There is too much or too low weight – emptying and refilling is required.	The cumulative load should be 16 tons, and definitely not exceed 17 tons.	Truck driver may be fined for overload. The truck is not filled and cost more money per ton of transported gravel.

Figure 6.17 Data sheet from the Simulation Interview regarding the bucket load weighing:

Users watch themselves on film and reports on important events that includes assessments or judgments. The user answers what action that are taken, then how the user assess the situation, what happens. Critical cues describe what the user rely on in the event and the potential errors what will happen if the situation is handled incorrectly.

Table. 6.3 Abstraction Hierarchy

<b>Situation</b>	Service co-users with equipment. Load, carry and move material and equipment on time.
<b>Task</b>	Fetch or excavate material and load it when requested. Communicate with co-users. Plan tasks sequences. Change sequence plans.
<b>Function</b>	Carry and transport different quantities and qualities of material. Use many different attachments attachable to it for different tasks. Load material or equipment. Produce force. Use communication instruments.
<b>Process</b>	Material is loaded, moved and unloaded. Engine produce power and propulsion, controls regulate hydraulic fluids, Mechanical arms translate hydraulic power. Variable speeds are possible; both powerful and transportation speeds. User manipulates mechanical arms and attached devices, steer and accelerate and break the machine. Use radio, visual cues, and mobile phone for communication.
<b>Structure</b>	Diesel engine. Levers in cabin, electrical cables and ECU, valves, Hydraulic motor and pipes, hydraulic pistons, hydraulic fluid, valves open and closes, hydraulic motor, hydraulic pistons. Information panel, up-lit buttons, short-wave radio equipment, telephone, reverse camera, windscreen.

## Discussion on operators mental models and expertise

The interviews in addition with the ACTA method gave a lot of input data on users' knowledge and the cognitive processes related to the work. However, mostly the whole system is described by these methods and the conclusions in relation to the control levers must be discussed further.

### Expert knowledge

The most complex and cognitive demanding part regarding the trench box was handling the slippery metal pieces. To use the big machine and fetch the box, the expert user had to reposition the machine, carefully lift and fetch the box and brings it closer to the machine using the levers with precise control. This can be considered a balance act that requires a lot of learning to know limitations and capabilities of the machine. Novices have difficulties assessing the positioning of the machine and use the controls to fine-tune the attachments. The cognitive demand is to picture the outcome of each small physical machine action. A factor that also impairs the performance is the fact that communication and phone calls interrupt the user's plans of execution. Orders of new tasks are often the source for interruption and the users are always available on mobile phone or short-way radio.

### Mental models

The theory about models is not conclusive and Sasse (1997) describe a vast spectra of model types, but it is enough to consider these following attributes of the wheel loader operators models:

The models are *internal* as it is formed and kept within the conscious mind.

They are *structural* to some extent. That means that the user has developed some model of the components of the system. As a structural model exist, it is not necessarily detailed or developed to an extent that helps the user if the structure fails (Andersson 2010). Here another expert, a mechanic is needed.

They are *incorrect* and not fully *detailed*, but detailed enough for the tasks to be executed.

They are foremost *functional*, as the user needs to understand what to do with the machine, how to maneuver it, in order to perform the task. The procedural knowledge of how to use the system is intricate and much depending on the task at hand, but from user interviews the expert can be regarded as an operator that performs each task with softer machine movements.

A mental model is also verbally expressed by a user as the thought of the machine as an extended arm and the user's feel of being "one with the machine" Another similar comment is also expressed in (Gellerstedt, 2002, p.16): (Translated from Swedish): "the most important, in order to do a good job, is to be comfortable with the machine; it should feel like an extension of your self and the motor and powertrain must work together in a good way."

## **Conclusion on operators' mental models and expertise**

Somewhere during the learning process the mental model of the machine acting as an *exoskeleton* might be developed; the user centered within an exoskeleton with artificial senses – outer system aural and visual communication, haptic sense through the machine haul and the hydraulic levers. The interface to the outer system is visual intake via the windscreen, haptic intake from physical touch and controlling the machine in the environment by the control levers.

### **Mental models**

To foresee how the course of events for unloading of the cargo will develop, a picture is based on mental models for different cargo. The event can be assumed to be a mental, as well as physical, balance act up held by the exoskeleton. In this model there is different additional models of scenarios foreseen, depending on how the equipment or material behave when loading or unloading, or under transport.

### **Expertise**

Experts are more aware of the capabilities of the machine; they have higher functional knowledge. They know the power limitations and the precision limitations and know in what situations the wheel loader can be used instead of doing manual physical work. The expertise knowledge is the wide use of the machine and the equipment; only the expert is capable of fine maneuvering as well as brutal force excavation of heavy material, but most workers around the wheel loader is assumed to be able to at least move the machine and quickly find the levers for maneuvering the hydraulics.

### **For concept development**

For better perception of the physical situation, between the machine and artifacts (in this case artifact is considered equipment, gravel, trucks etc.), haptic feedback from the pedals and levers could help the user. This might help the user to understand if hidden part of the machine and attachment is touching the artifact. The levers could also be designed to have an absolute positioning. This would mean that the lever stays in a chosen position and the attachments gets positioned in analogue to this.

As the user works with the machines as an extension of their own body, the future design should not cause any mismatch or impair the connection between the control levers and machine response. In short this could mean that there should not be any slack in the levers or delays in the hydraulic system. Natural mapping is also an imaginable design feature that could reduce risks for error and reduce learning curves.



# 7 Problem definition

*This is the synthesis of the previous theory research and analysis. It aims the project towards a solution to what problem to solve. The problem is described by conclude the analysis and theory as state what could improve the work. A set of needs on the project from different aspects condense the aim for the product development. After this problem definition, a set of design heuristics to solve ergonomic issues is presented.*

## 7.1 Conclusion from theory and analysis

The physical ergonomic theory (*chapter 3.1*) revealed the complexity of the hand, problems that might occur and the underlying reasons. The performance of hand movements and the precision of it that controls wheel loaders, is mind staggering and it is amazingly performed by forces originating from muscles that is mainly situated far away in the forearm. Any movement angles the joint and the angles should always be as close to neutral angles as possible. The User Profile (*chapter 6.2.1*) and task analysis (*chapter 6.2.2*) gave good insight into the problems that currently surround the use of the product today. These results were important for the rest of the analysis and gave focus to where to pinpoint the methods. The observation study (*chapter 6.2.3*) showed a large amount of possible postures and that there are individual postures for the same work.

The ergonomic simulation in Jack (*chapter 6.3.2*) showed bad comfort angles in current postures. Posture related issues are stretched finger postures, high level of repetition frequency, static workload in the shoulders and requirements of precision maneuvering. The ergonomic simulation also showed how a good posture can look like and what that has to be changed to achieve this. The anthropometric analysis (*chapter 6.3.1*) showed what measurements are important when designing new control levers and the level of adaptability that is needed to suit the 5<sup>th</sup> to 95<sup>th</sup> percentile of the world population. But to explain why discomforts occur, considerations must be taken to the system requirements and effect on the user: there are large vibrations and higher and higher demands on the work performance. Although, the work do not clearly induce occupational disorders other than in a long-term perspectives. One isolated posture cannot be defined, however does the anthropometric data, together with the ergonomic simulation and observations, show some results that can be concluded from the inferior ergonomics of the current product.

Small movements can easily have the effect that smaller muscles are used, that induce discomforts and in the long run inflammations. Overall desires to improve the ergonomics in the wheel loader, and the in work with the levers, is to activate more muscles in the forearm to decrease risk for inflammations, and at the same time keep the muscle movements as small as possible close to the neutral position (*chapter 3.3.1*). The armrest must fully support the arm to decrease risk for the Cinderella muscle deterioration (*chapter 3.1.4*), but the lever handle and motion pattern must also provide variation of grips. The system surrounding the user must also provide micro-breaks to fully rest all muscles.

Cognitively the operators are put under a lot of pressure. The perception (*chapter 6.4.1*) for a novice operator with limited experience and knowledge could be reinforced if using multimodality senses to increase the bottom-up processing. Also experienced operators would gain from perception from multimodality senses – being able to work more efficient with precision work.

The mental model analysis (*chapter 6.4.2*) showed that expert operators have higher functional knowledge than novice operators – making it possible to more quickly maneuver the hydraulics, perhaps it can be regarded that the user use the machine as an exoskeleton. The structural knowledge of the expert operators may in a long-term use of the machine lead to lower fuel consumption and a less wear and tear of the machine. The interface from the outer system is visual intake via the windscreen, haptic intake from physical touch and situation awareness from the structural system via instrument panel.

Spoken needs from Stakeholders

There is a market need of controlling wheel loader attachments with a single lever. This market need is mainly addressed from markets with machines only using two hydraulic functions, but the project initiators see an opportunity to integrate all four hydraulic functions as options, into the single lever. It would then be possible to have all four hydraulic functions reachable without having to change the grip – which would make the work more efficient also for those using all four functions.

The stakeholders want a lever that is designed for wheel loader environment, and be differentiated on market. It should have the same functionality as the current linear control levers, which puts a demand on all four functions to have proportional characteristics. A spoken desire from the stakeholders is that the concept should consist of existing technical solutions.

## 7.2 Summary of needs

The different needs, both spoken and interpreted from the data from all previous chapters, are summed in *table 7.1* and *table 7.2*. These needs are statements of what the final product should be, and what it should do mostly in the users' aspect. Needs from stakeholders (regarded as initiators and other internal sources) are most often spoken and have been collected during meetings and other contacts. The end-users needs have been withdrawn as spoken needs from the interviews and analysis, but also been constructed from conclusions made from the theory and analysis. The market needs have been derived via stakeholders and by contact with market agents.

### 7.2.1 Contradictive needs

The delimitation of using existing technical solutions is mostly in contradiction the some cognitive ergonomics needs. The feedback, tactile and audial, is not feasible features in this project, as neither force-feedback nor audio feedback is available in existing technical solutions. The fact that the housing must fit existing plastic cover and the metal bracket, delimits the form development. Also, to be able to adjust the housing in the transverse plane is regarded difficult, as the existing metal bracket must be used.



Table 7.1 Stated needs for handle

Area of need		Needs	Source(s) of input	Spoken or interpreted	Demand or Wish	Ranking 3=High; 1=Low
<b>Handle</b>						
<b>Physical ergonomics</b>	1	Suit 5th to 95th percentile of the world population	Stakeholders	S	D	3
	2	Provide comfortable grip	Interpreted	I	D	3
	3	Allow reachability of lift, tilt, 3 <sup>rd</sup> & 4 <sup>th</sup> function without changing grip	Stakeholders, end-users	S	W	3
	4	Provide a grip close to the natural position.	Interpreted	I	W	3
	5	Provide variation of grips: precision, power, or resting.	Interpreted	I	W	1
	6	Avoid unintentional activation of functions	Interpreted	I	W	3
<b>Cognitive ergonomics</b>	7	Be able to slowly and precisely control the hydraulics	End-users	S	D	2
	8	Allow simultaneous use of functions	Interpreted	S	W	2
	9	Provide natural mapping	Interpreted	I	W	2
	10	Give users hint of directions of the lever	Interpreted	I	W	2
	11	Provide tactic feedback	Interpreted	I	W	1
	12	Have audio feedback	Interpreted	I	W	1
<b>Market needs</b>	13	Functionality as a joystick	Stakeholders, market agents	S	W	3
	14	Be a mini-lever/joystick	Interpreted, market agents	I	W	1
	15	Single lever with Power-grip (Hand-arm lever)	Stakeholders	S	W	1
<b>Aesthetics</b>	16	"Clean" design: e.g. no unnecessary buttons	Stakeholders	S	W	1
<b>Technical limitations</b>	17	Have the provided sensors for 3 <sup>rd</sup> and 4 <sup>th</sup> function	Stakeholders	S	D	3

Table 7.2 Stated needs for housing and buttons

Area of need		Needs	Source(s) of input	Spoken or interpreted	Demand or Wish	Ranking 3=High; 1=Low
<b>Housing</b>						
<b>Physical ergonomic</b>	18	Suit 5th to 95th percentile of the world population	Stakeholders	S	D	3
	19	Provide a reference point	Stakeholders	S	D	2
	20	Allow hand support	Interpreted	I	D	1
	21	Follow chair / armrest	End-users	S	D	2
<b>Aesthetics</b>	22	Have as low thickness as possible	Interpreted	I	W	1
	23	Have as petite size as possible	Interpreted	I	W	1
<b>Technical limitations</b>	24	Have one of the provided joystick solutions	Stakeholders	S	D	3
	25	Fit the existing metal bracket	Stakeholders	S	D	3
	26	Should fit existing plastic lower cover	Stakeholders	S	D	3
<b>Buttons</b>						
<b>Physical ergonomics</b>	27	Be easy to distinguish between each other	Interpreted	I	W	3
	28	Be easy reachable	Interpreted	I	W	2
<b>Technical delimitations</b>	29	Be same type and model as existing product	Stakeholders	S	D	3

## 7.3 Design Heuristics

Depending on the concept development and the characteristics of the new design (like if precision grip or power grip is implemented), the physical design should follow physical design heuristics withdrawn from previous chapters. The interaction between the user and machine must also be taken into consideration. To aim the concept development design heuristics are set on basis of all previous work.

### 7.3.1 Physical ergonomics design heuristics

The problem with today's solution is that to do certain tasks an operator would have to use the hand in many different postures that put strain hand and fingers requiring extension and flexion of fingers in the border regions of comfort. To facilitate better comfort a new design of controls are needed that would require less deviation from acceptable angles and postures. The ideal would be a control that operates close to the neutral position of the hand enabling the operators to rest the hand and arm muscles. The most important aspects to take into consideration are placement of armrest and hand support, seat design to facilitate comfort for many users, enable variation, change postural requirements, change handle design, change how the work is performed and working tasks during a day to facilitate variation.

#### **Physical ergonomics heuristics**

- 1 Hand and wrist angles should be close to the neutral plane
- 2 It should meet recommendations in shape; cross sections, curvature etc.
- 3 Any surface the user touch should provide good comfort
- 4 Anthropometric data of hands should be used for design choices
- 5 Use thumb and index finger for precision control
- 6 Consider the relation of the armrest and control unit regarding adjustability
- 7 Contemplate the actuating forces and optimize them for the task.
- 8 Provide a rest support for muscle relief or as an anvil
- 9 Provide different hand postures or grips.

### 7.3.2 Cognitive ergonomics design heuristics

There is no source for recommendations available as for cognitive ergonomics. Instead, a set of design heuristics based on the cognitive ergonomics analysis, sets the aim for the redesign. As the interaction is mostly done without the users seeing the control unit, the tactile characteristic is mainly the cognitive ergonomic aspect to take into consideration. The analysis of the senses and modality within this system derived a chance of the new lever design to enhance the perception. When reflection on mental models and expertise the most important heuristic is to keep the user "close" to the machine; that is not to alienate the user, instead let the user feel and control the vehicle without disturbances or delays etc. Also, with the great spread of tasks that are performed with a wheel loader in mind, ideas of letting the user to change the machine to the task instead is a innovative aspect of the redesign. This is in contradiction of the non-changeable settings of current products that forces the user to adapt to the task.

## Cognitive ergonomics heuristics

1. Increase usage of multimodality sensor perception
  - Audio signals should be dedicated for warning signals
  - Force-feedback in levers can heightens perception and complement visual intake
2. Increase sense of control
  - Instant force-feedback from the controls
  - Instant machine response from the controls
  - Natural mapping reduce learning curve and time for decision-making
3. Adapt the machine to the task
  - Different force-feedback in controls in different use scenarios
  - Task depending settings, such as machine response etc.
  - Task depending information, such as lever labels etc.

### 7.3.3 Discussion of contradictive needs and heuristics

Stated in the introduction, one of the goals for this project is to use existing technical solutions. Most of the cognitive ergonomic heuristics is regarded to mostly depend on such technical solutions. For instance: force-feedback does not exist today, and existing computer system in the wheel loaders is not possible to alter to accommodate this. Neither the design heuristics of adapting the machine to different task seems to be possible without changing the technical requirements.

The only remaining design heuristic for cognitive ergonomics possible to consider in the further work, is the machine response. This is derived to depend on the calibration for any joystick base chosen. The calibration is a remapping of the software in the wheel loader control system that will be done in a much later phase of the project that the thesis work is not in contact with at this stage. Thus, the data collection and work of deciding what technical solutions to use is out of the scope if this project so for the concept development, only the physical heuristics can be implemented.

# 8 Concept generation 1

*The first concept generation phase was broad and focused on all from simple to out of the box ideas with the goal to find a main concept approach to develop further. Mock-ups were an important part of the idea generation and a lot of new ideas came up while working in the workshop creating these mock-ups.*

## 8.1 Idea generation

A spoken wish from the project initiators was to come up with a mini-joystick concept, therefore many ideas revolved around the mini-joystick concept, but in order to not get stuck in one direction the first idea generation was not limited to any specific concept focus. The goal of the idea generation was more about finding differed solutions for palm-sized (or smaller) control handle or handles that could be controlled without changing the grip.

The idea generation process consisted of brainstorming sessions (*chapter 4.3.1*) where sketches were used to generate ideas mixed with workshop sessions where the ideas were created, further developed and evaluated iteratively using mock-ups (*chapter 4.3.3*). A selection of the generated ideas can be seen in the mock-ups (*figure 8.1*) and the sketches (*figure 8.2*) presented in the following figures.

### Mock-ups



*Figure 8.1. Mock-ups created during first concept generation:*

*A linear lever base and a joystick-base were used to try out the mock-ups. An easy to process blue coloured polyurethane (PU) foam was used to build the mock-ups in. The focus during the workshop sessions was primary to solve how to control the lift and tilt function but also to experiment in different ways of solving the 3<sup>rd</sup> and 4<sup>th</sup> function. The mock-ups gave valuable input to what shape and sizes that felt good in the hand and would fit different hand sizes. The idea generation would not have been as successful without the mock-ups.*

## Sketches of control lever ideas

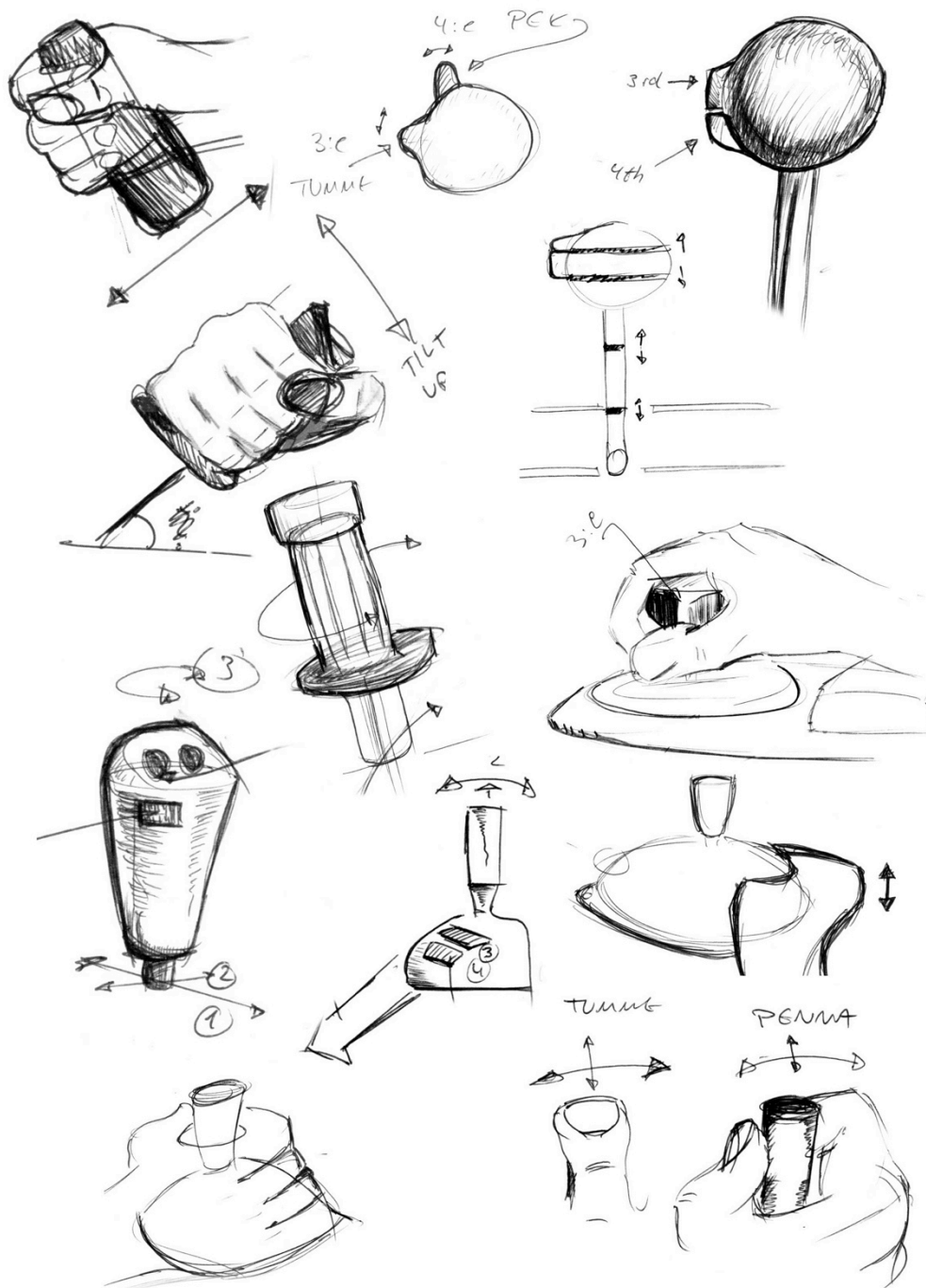
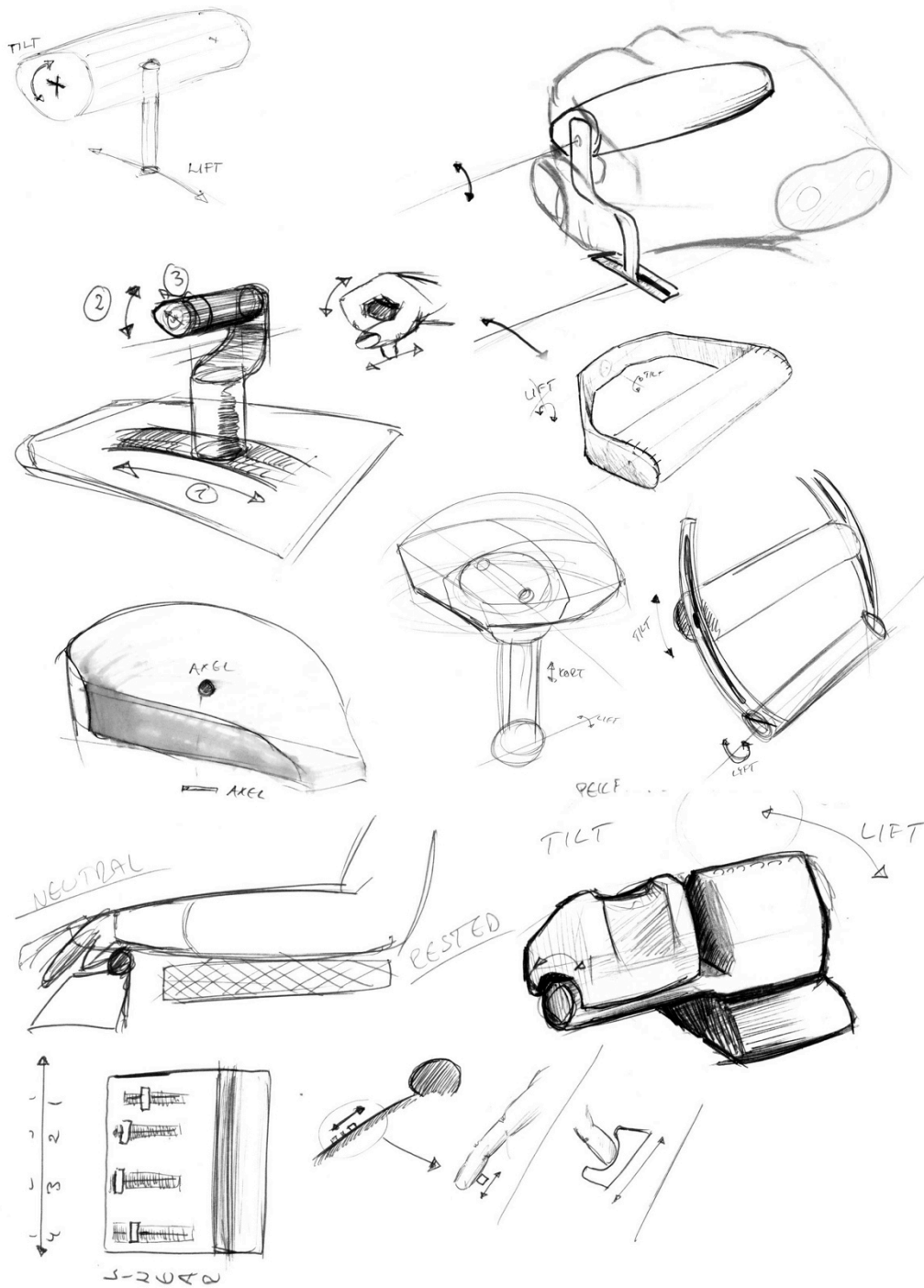

Figure 8.2 Sketches from first ide generation:

The ideas that came up during the sketching session were to either use a palm sized handle or finger-sized control and to either use joystick or a linear lever as base of movement. Regarding the shape the aim was to keep it simple to enable a good grip for operators with different hand sizes.



## 8.2 Concepts

The ideas from the idea generation were grouped together resulting in three different approaches with five different concepts. The first approach was a mini-joystick, the second a thumb- index finger joystick and the third a joystick with separated pivot points.

### Mini-joystick 1

In the mini-joystick 1 concept (*figure 8.3*) *lift* and *tilt* is controlled using a joystick. The 3<sup>rd</sup> and 4<sup>th</sup> function is controlled using two scroll wheels. The handle is angled to enable a neutral hand and wrist position and to avoid supinating the wrist. The handle is sized for the palm holding a power grip. The advantage of the concept is the reachability of all functions at the same time. The disadvantages are a poor natural mapping of *lift* and *tilt* and poor precision of *lift* and *tilt*.

### Mini-joystick 2

The *mini-joystick 2* concept (*figure 8.4*) is also controlled using a joystick. The handle has a spherical shape so that the operator's hand can rest upon the handle and a protrusion on the side, giving the operator a better grip when controlling the 3<sup>rd</sup> and 4<sup>th</sup> function. The handle is horizontally divided in one upper part and one lower part. To control the 3<sup>rd</sup> function the operator turns the upper part of the sphere using the whole hand. To control the 4<sup>th</sup> function the operator turns the lower part of the sphere using the thumb, index or middle finger. To prevent unnatural stretching of fingers the lower part of the sphere always follows the movement of the upper part. When controlling the 4<sup>th</sup> function the position of the lower sphere will be measured in relation to the upper sphere. The advantages with the *mini-joystick 2* concept is that it enables a variation of grip and that it enables a natural rest posture for the hand on top of the lever during micro breaks. The disadvantage with the concept is that the wrist will be deviated when using the 3<sup>rd</sup> function. The concept also requires a longer implementation time, since the components for the sphere cannot be bought from any supplier.

### Thumb- index finger joystick

The *thumb- index finger joystick* concept (*figure 8.5*) has a fixed clump that the hand can rest against. *Lift* and *tilt* is controlled using a joystick placed on the clump. The joystick has a switch sized to enable a grip using the thumb and index finger. The 3<sup>rd</sup> and 4<sup>th</sup> function is controlled using either two scroll-wheels or two *mini-finger levers* placed on the backside of the clump. The advantages with the concept are that the hand can be placed in a rest posture and that the wrist will be in a neutral position. The disadvantages are that it might be hard to achieve a high precision using a small switch and that it will be hard to use *lift*, *tilt* and 3<sup>rd</sup> and 4<sup>th</sup> function.

### Palm pivot lever 1 & 2

The idea with the *Palm pivot lever* concept is to separate the *lift* and *tilt* function to two separate rotation points. So instead of a joystick the *palm pivot lever* is like a linear lever with an extra rotation axis on top. *Lift* is controlled by pressing/pushing the lever and *tilt* is controlled by tilting the handle sideways. In the *Palm pivot lever 1* concept (*figure 8.6*) the handle is cylindrical with an egg-shaped cross section. The 3<sup>rd</sup> and 4<sup>th</sup> function is controlled using either a rocker switch or scroll wheel. The handle of the *Palm pivot lever 2* concept



(figure 8.7) is clump-shaped to give a more comforting support for the hand. The 3<sup>rd</sup> and 4<sup>th</sup> function can either be controlled using scroll wheels or *mini-finger levers*. The advantages with the two *Palm pivot lever* concepts are that the wrist will be in a neutral position, there is a natural mapping of *lift* and *tilt* and there is also possible to achieve a higher level of precision when *lift* and *tilt* is separated. The disadvantage with the concept is that it would require a quite long implementation time.

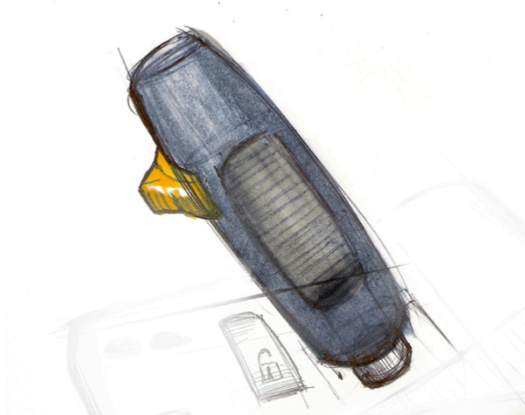

Figure 8.3 Mini-joystick 1



Figure 8.4 Mini-joystick 2

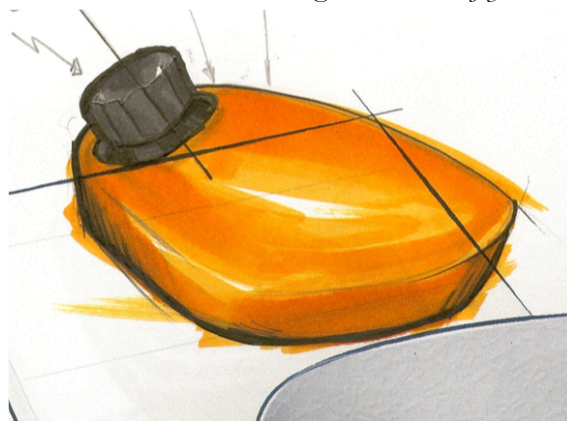

Figure 8.5 Thumb- index finger joystick

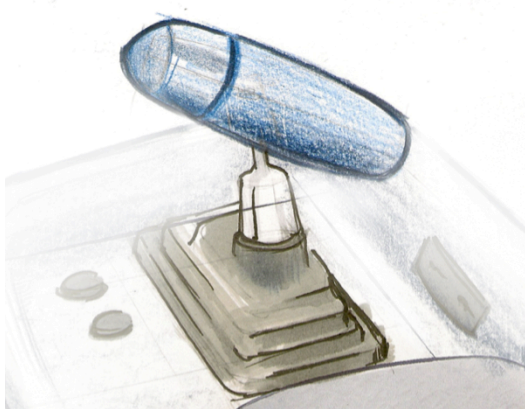

Figure 8.6 Palm-pivot lever 1

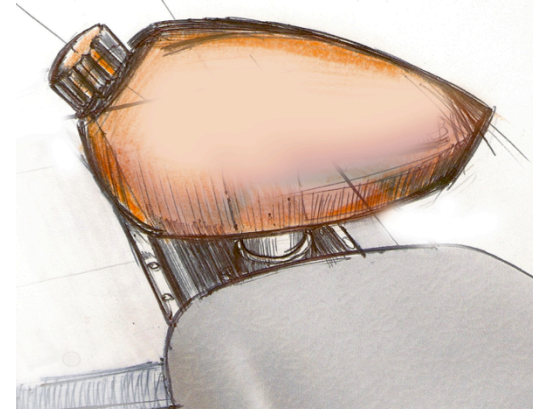

Figure 8.7 Palm pivot lever 2

## 8.3 Concept selection

### 8.3.1 Concept screening

The concepts were evaluated using concept screening (*chapter 4.4.1*). The result from the concept screening can be seen in *table 8.1*. Needs were used from the problem definition (*chapter 7.2*) such as reachability of functions, neutral grip position, natural mapping and technical feasibility. In addition to the criterions three scenarios were used to evaluate the simultaneous usage of the function, see below:

- Scenario 1 Snowplow: Operator adjusts two blades and *lift* and *tilt* at the same time (*Lift*, 3<sup>rd</sup> and 4<sup>th</sup> function).
- Scenario 2, Bucket work: Operator adjusts *lift* and *tilt* for loading gravel and planning gravel (*Lift* and *tilt*).
- Scenario 3, Grabbing timber: Operator simultaneously adjusts *lift* and *tilt* and then closes grappler (*Lift*, *tilt* and 3<sup>rd</sup> function).

*Table 8.1. Concept screening – First idea generation phase*

	Reference: Linear levers	Mini-joystick 1	Mini-joystick 2	Thumb- index finger joystick	Palm pivot lever 1	Palm pivot lever 2
<b>Selection criteria</b>						
Reachability of functions (Need 3)	0	+	+	-	+	+
Neutral grip position – Wrist Flexion/extension (Need 4)	0	+	+	+	+	+
Neutral grip positions – Wrist Deviation (Need 4)	0	+	-	+	+	+
Neutral grip position - Fingers (Need4)	0	+	+	0	+	+
Variation of grip (Need 5)	0	-	+	0	0	+
Precisely control of the hydraulics (Need 7)	0	-	-	-	0	0
Simultaneous use of functions in scenario 1 (Need 8)	0	+	+	-	+	+
Simultaneous use of functions in scenario 2 (Need 8)	0	0	0	0	+	+
Simultaneous use of functions in scenario 3 (Need 8)	0	+	+	-	-	-
Natural mapping of <i>lift</i> and <i>tilt</i> (Need 9)	0	-	-	-	+	+
Natural mapping of 3 <sup>rd</sup> function (Need 9)	0	0	0	0	0	0
Natural mapping of 4 <sup>th</sup> function (Need 9)	0	0	0	0	0	0
Ease of use (Need 9 & 10)	0	0	0	0	+	+
Technical feasibility (Need 17 & 24)	0	0	-	0	-	-
+ Score	0	6	6	2	8	9
- Score	0	3	4	5	2	2
<b>Total</b>	<b>0</b>	<b>3</b>	<b>2</b>	<b>-3</b>	<b>6</b>	<b>7</b>

The concept that got the highest score was the *Palm Pivot lever 2*. The separations of the pivot points for *lift* and *tilt* would both increase the natural mapping of the third and fourth function and improve the natural wrist position. Unlike the *Palm Pivot lever 1* concept the *Palm Pivot 2* concept gave a better variation of grips and therefore got a slightly higher scoring.

### 8.3.2 Input from the reference group

The concepts were also evaluated using the reference group (*chapter 4.4.4*) from Volvo. The group was first given a background presentation of the project and concepts were thereafter presented one by one. After each concept presentation the seven participants were able to sit in the armrest rig (*chapter 4.4.2*) where a mock-up of the concept was mounted. Afterwards they filled out a form of what they thought about the concept so that they wouldn't forget their thoughts. When all concepts had been presented and all participants had been able to sit in the rig to try the mock-ups there was a vote in which all participants had to choose one primary concept and an alternative concept that would like to be further developed.

In the overall result the *Mini-joystick 1* was voted as primary choice and the *Palm pivot lever 2* was voted as secondary choice for further development. The major reason that the *Mini-joystick 1* was selected as primary choice was because it was "a safe card" and that it felt good in the hand. The input given for further development was to make the handle a little bit thinner and smaller and to reduce the forward/backward movement of the joystick.

Most participants liked the concept *Palm pivot lever 2*, but thought it was hard to determine if the concept would function in reality and be feasible to construct. A real prototype would be needed in order to make that decision. The participants said that the *Palm pivot 2* was comfortable, gave a good support for the hand and had reachable buttons and thumb wheels.

### 8.3.3 Conclusion and selection of concept for further development

The two preferable concepts were the *Palm pivot lever 2* and the *Mini-joystick 1* concept. The *Palm pivot lever 2* concept is the most innovative since it introduces a new kind of joystick with separated pivot points. The disadvantage with the concept is that it would require longer implementation time than the *Mini-joystick 1* concept and the fact that there are not any existing sensors at the suppliers would make it hard to build a functional prototype to evaluate in machine. Because of the feasibility of the concept and the fact that it was the reference group's primary choice, the *Mini-joystick 1* was selected for further development. Although, some features from the *Palm pivot lever 2* could be combined with the chosen primary concept.



# 9 Concept generation 2

The second concept generation focused on generating new solutions for the Mini-joystick concept that were selected for further development in the first concept generation phase. A morphological matrix was used as main source for the idea generation and mock-ups were used for verifying the ideas. Only three concepts were generated in this phase in order to be able to focus more on the details for each concept.

## 9.1 Idea generation

The morphological matrix (chapter 4.3.3) was used to find new solutions of the *mini-joystick* concept that hadn't been thought of before. From the start the goal was to come up with three new concept ideas. The three concepts generated from the morphological matrix (figure 9.1) are described more detailed in chapter 9.2.

Mock-ups were built of the three concepts (figure 9.2). When building the mock-ups it was noticed that the stroke angle from the joystick's min and max position required quite large lower arm movements. To compensate for the movement a better arm and wrist support would be needed. Even if it is outside of the project's scope two ideas of increasing the wrist and arm support were developed (figure 9.3). The button placement for the control unit was not prioritized in this phase, however some ideas were generated through sketching and try-outs in the workshop when building the mock-ups (figure 9.4).

### Morphological matrix

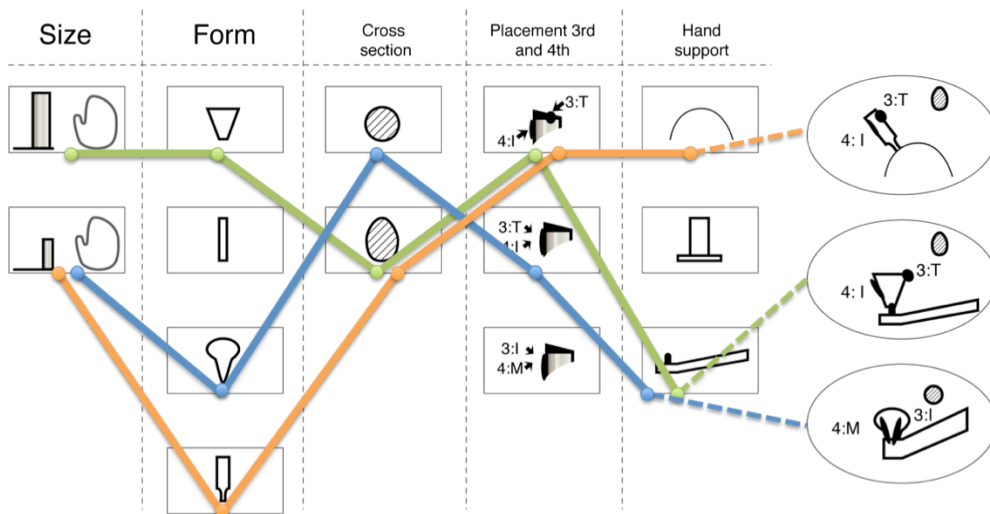
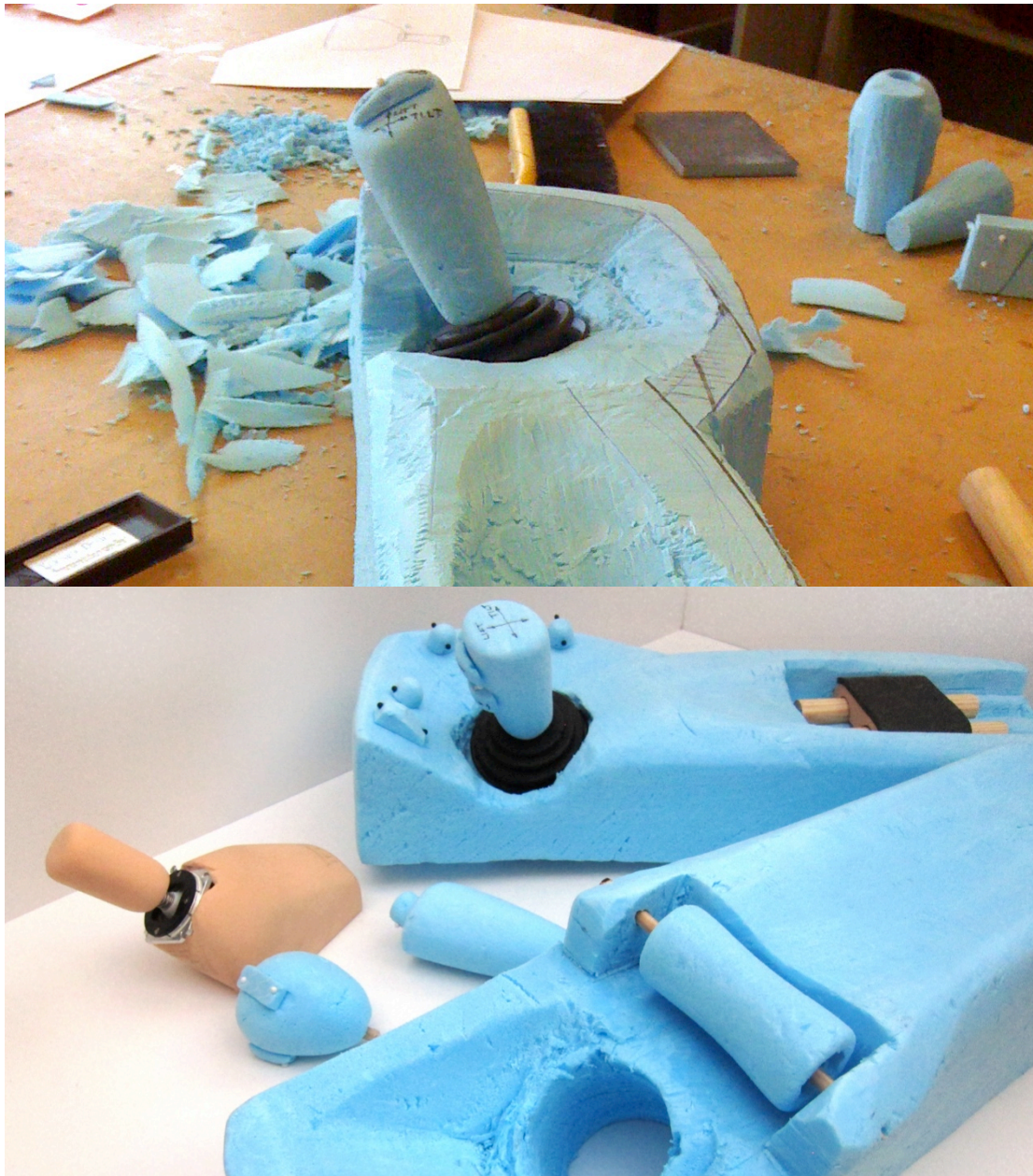

Figure 9.1. Morphological matrix.

Different combinations of size, form, cross-section, placement of 3<sup>rd</sup> and 4<sup>th</sup> function and what kind of hand support to use were used to evoke new concept ideas. The size could either enabled a full palm grip or enable a looser finger grip. Regarding the form there were four different alternatives; conic, cylindrical, spherical and cylindrical shape with a hollowing in the bottom. The cross section could either be round or egg-shaped and the hand support could either be given using a base separated from the handle, using a support at the bottom of the handle or by integrate the control lever in the armrest using the armrest as support.



## Mock-ups



*Figure 9.2 Mock-ups second idea generation.*

*Two different joystick bases were used for trying out the concepts. To be able to mount the second joystick base another peach colored Polyurethane (PU) foam was used that had a higher density. Due to time limitations the control unit for the base concept and the mounting to the arm support was not finished.*

### Sketches wrist and arm support and control unit

The *wrist roller idea* (upper sketches in *figure 9.3*) consists of a non-friction roller. When moving the wrist forward and backwards the wrist can roll on the roller, helping the wrist to be straight instead of tilting up the hand. When moving the wrist sideways the wrist can lean against the support without having to lift the arm. For the upper arm/shoulders to be relaxed the lower arm needs a good support – a support that gets lost when the arm is moved forward and backwards. Using the *sliding arm support* (lower sketches in *figure 9.3*) the lower arm will still be supported when moving the arm-

The placements of the functions from the control unit were prioritized based on the importance to the following: (from the left in *figure 9.4*) *Kick-down*, *Engine break*, *Horn*, *Direction selector*, *Activation of Direction selector* and *Lock control*. The idea was to place the button along an arced line so that the different buttons can be reached using different fingers.

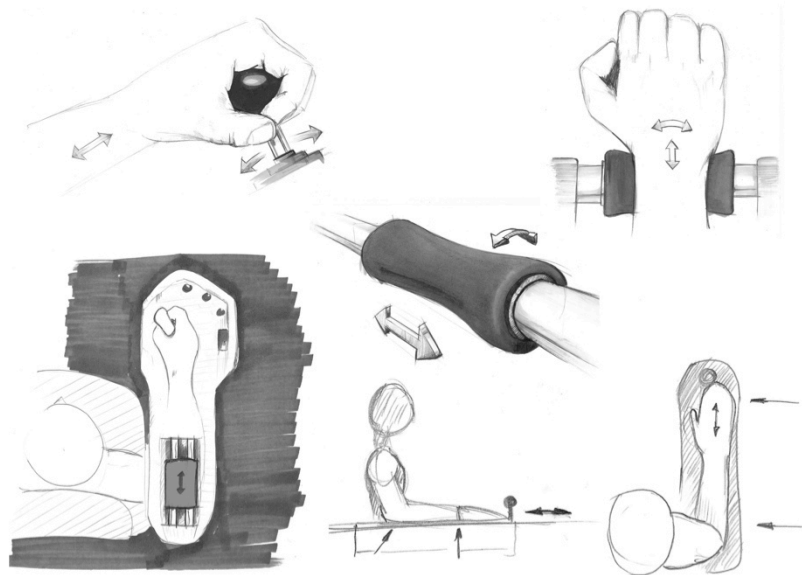

Figure 9.3. Sketches wrist and arm support.

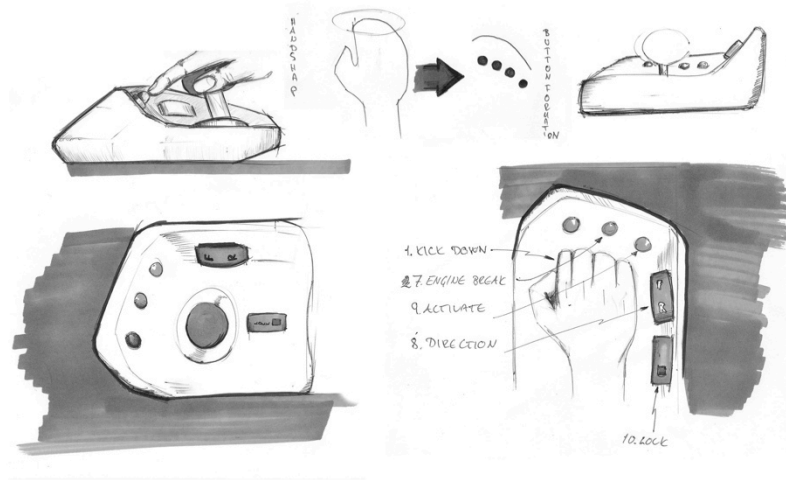

Figure 9.4 Control unit

## 9.2 Concepts

The three concepts generated from the morphological matrix will here be presented. The first is called *Classic*, the second *Pear* and the third *Base*.

### **Classic**

The *Classic* concept (*figure 9.5*) is sized to enable a full power grip. The handle is angled to achieve a more natural wrist position when controlling the lever. The form is slightly conical with an egg-shaped cross section. The 3<sup>rd</sup> function is placed on top of the handle, controlled using the thumb, and the 4<sup>th</sup> function is placed on the front of the handle, controlled using the index finger (not visible in figure). The advantages with the concept are except the neutral wrist position also a minimization of wrist movement and the fact that the control unit is integrated in the armrest. The disadvantages are that the amount of different grips are limited and that there is a risk for unwanted lever activation when the hand is in its rest position.

### **Pear**

The *Pear* concept (*figure 9.6*) is spherical in shape with a round cross section to enable a variation of grips. It can e.g. either be griped from the top or from the side. Another advantage with the shape is that it will fit different hand sizes. The 3<sup>rd</sup> and 4<sup>th</sup> function is placed on the front of the handle using the thumb and index finger to control them. The disadvantages with the concept is that the hand's distance from the joystick's pivot-point might give less precision and that there is a risk for undesirable lever activation when the hand is in its rest position. Another disadvantage is that gripping from the top will require larger hand movements sideways when controlling the joystick, this have however could be solved using the *wrist-roller concept* that will follow the wrist side movements giving a continuous wrist support.

### **Base**

The *Base* concept (*figure 9.7*) consists of the joystick handle being placed on a base that provides the operator with a reference support when controlling the lever. The handle is cylindrical with a slightly egg-shaped cross-section. The 3<sup>rd</sup> function is placed on top of the handle and the 4<sup>th</sup> function is placed on the front of the handle. The advantages with this concept are that it enables a good rest position and grip variations for the hand. It also fits different hand sizes. The disadvantages with the concept is that there may be flexion or deviation of the wrist while controlling the lever and that there may be extensions of fingers while controlling the third and forth function.



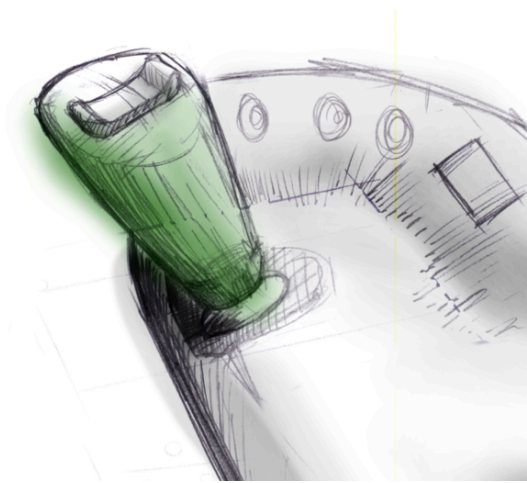

*Figure 9.5 Classic joystick*

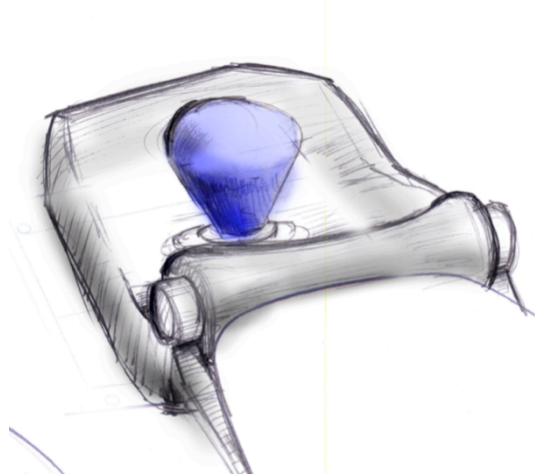

*Figure 9.6 Pear concept*



*Figure 9.6 Base concept*

## 9.3 Concept selection

### Concept screening

The concepts were quite similar and there was not any reference concept to compare the concepts with. The three concepts were instead compared to each other. Criteria from the needs in the problem definition (*chapter 7.2*) were selected to highlight the difference between the concepts; comfortable grip, neutral grip position, variation of grip, reference point and hand support. The concepts were scored using a three-level scale where three was the highest score and two the lowest score. None of the concepts could be given the same score.

The result from the screening shows that the *Base* concept got the highest score. It was defined as the most comfortable of the three concepts, enabling both a good rest position and a good precision grip (*table 9.1*).

*Table 9.1 Concept screening – second idea generation phase*

Selection criteria	Classic	Pear	Base
Provide comfortable grip (Need 2)	2	1	3
Neutral grip position – deviation/flexion/extension (Need 4)	3	2	1
Provide variation of grip (Need 5)	1	3	2
Provide reference point (Need 19)	2	1	3
Allow hand support (Need 20)	2	1	3
<b>Total</b>	<b>10</b>	<b>8</b>	<b>12</b>

### Input from reference group

The three concepts were evaluated using the same reference group (*chapter 4.4.4*) as evaluated the first concept generation phase, following the same procedure (*chapter 8.3*). All participants voted the *Base* concept to be their primary choice. The secondary choice was equal between the *Pear* and the *Classic* concept. The participants thought the gripping of the *base* concept felt more natural than with the other concepts. They liked that the base could be used as a support when it got bumpy in the machine and also that the grip could be altered between a full handgrip and using a more light finger grip.

### Conclusion and concept selection for further development

The concept selected for further development was the *base* concept. In both the concept screening and from the evaluation with the reference group the *base* concept was appointed as the best concept.

# 10 Concept generation 3

When the base concept from the second concept generation was selected it was time to develop a functional prototype that could be tested in a real wheel loader. Before developing the functional prototype the concept had to be refined to keep a high ergonomic quality and needs from chapter 7.2 were elaborated, which is presented in chapter 10.1. The guidelines from the elaboration were used when the handle and base were further developed and the control unit created. Chapter 10.2 highlights the most important factors and challenges to why the concept ended up the way it did and presents the finished prototype. A more detailed concept description of the concept can be found in chapter 10.3.

## 10.1 Elaboration of needs from chapter 7.2

In order to refine the selected concept, keeping a high ergonomic quality, the ergonomic needs (chapter 7.2) were elaborated further and guidelines were developed of how the needs could be fulfilled. The elaborated needs related to the handle can be seen in table 10.1 and 10.2. The elaborated needs related to the housing can be seen in table 10.3 and the elaborated needs for the buttons can be seen in table 10.4. Need nr. 11 (table 7.1) about tactile feedback have been removed due to technical limitations with the joystick used in the concept. Need nr. 12 (table 7.1) about audio feedback have been removed to not overload the operator's mental workload. Audio feedback should only be used to warn or alert the operator.

Table 10.1 Elaboration of physical ergonomic needs for the Handle

Handle - Physical Ergonomics				
	Needs		Elaborated Need	Guidelines
1	Suit 5th to 95th percentile of the world population.	1.1	Have length enabling a power grip.	Length should be min 95,4 to fit the 95th percentile of a USA male's handbreadth. (Table 6.1)
		1.2	Have length enabling reach for 3 <sup>rd</sup> function	Length should be max 65,9 mm to fit the 5 <sup>th</sup> percentile of a Chinese female's handbreadth. (Table 6.1)
		1.3	Have thickness enabling a power grip.	Recommended thickness for handles 30 – 50 mm. (Haslegrave & Pheasant, 2006)
		1.4	Have thickness enabling a precision grip.	Recommended thickness for handles 8 – 16 mm. (Haslegrave & Pheasant, 2006)
2	Provide comfortable grip.	2.1	Have good overall shape.	Handles used in gripping should have a slight curvature to follow the shape of the hand. (Haslegrave & Pheasant, 2006)
		2.2	Have good detailed shape	Sharp edges should be avoided to eliminate force hotspots (finger grooves, handle shapes etc.) (Haslegrave & Pheasant, 2006)
		2.3	Have good transition between surfaces.	Recommended min radius 25 mm. (Haslegrave & Pheasant, 2006)
3	Allow reachability of lift, tilt, 3 <sup>rd</sup> and 4 <sup>th</sup> function without changing grip.	3.1	Integrate 3 <sup>rd</sup> and 4 <sup>th</sup> function in handle .	Avoid using fingers connected with the same extensors for different controls. Lift and tilt controlled with fingers or the whole hand. 3rd function controlled with thumb. 4th function controlled with middle/ index finder.
		3.2	Have good distance between 3 <sup>rd</sup> and 4 <sup>th</sup> function.	No anthropometric data available for this relation. Evaluation in workshop is necessary.

4	Provide a grip close to the natural position.	4.1	Enable a natural forearm position.	The forearm is more powerful if being angled towards the bodyline. The handle of a joystick with a stroke angle of $\pm 19^\circ$ should be between $19-71^\circ$ towards the bodyline.
		4.2	Enable a natural hand position.	A handle used for power handling should have $20^\circ$ parallel with the bodyline to shape after the finger lining when gripping. (Gilbert et al, 1988)
5	Provide variation of grips.	5.1	Provide variation of grips.	The usage of different grips will divide the muscular stress on several muscles, which will reduce the risk of Cinderella hypothesis.
6	Avoid unintentional activation of functions.	6.1	Enable a good design of switches.	Avoid possibility of getting caught with something in the switches.
		6.2	Enable activation/inactivation of function.	Have a possibility to activate and deactivate electric signal to handle.

Table 10.2 Elaboration of cognitive ergonomic needs for the Handle

Handle – Cognitive Ergonomics				
	Needs		Elaborated Need	Guidelines
7	Be able to slowly and precisely control the hydraulics.	7.1	Have proportional characteristics (All four functions).	No recommendations are available for recommended stroke length. Evaluation in machine is necessary for all four functions.
		7.2	Enable a good grip of switches.	The switches should either be in a high friction material or have ribs or grooves in the shape to increase the friction.
8	Allow simultaneous use of functions.	8.1	Amount of functions controlled.	Max 4 control mechanisms located on the same control.
		8.2	Simplify balance between Lift and Tilt for a novice operator.	The usage of a joystick gives an advantage of controlling two functions with one single movement.
		8.3	Control of a two bladed snowplow.	The 3 <sup>rd</sup> and 4 <sup>th</sup> function has to be able to be controlled in the same way and in relation to each other. They should therefore be controlled in the same direction.
9	Provide natural mapping.	9.1	Provide a good direction of control.	The movement of the controls in relation to their neutral position shall be in the same general direction as the machine response.
10	Give users hint of directions of the handle.	10.1	Have an intuitive shape.	The cross section of a handle should be somewhat egg-shaped to set the direction of the handle. (Hägg et al, 2009)

Table 10.3 Elaboration of physical ergonomic needs for the Housing

Housing – Physical ergonomics				
	Needs		Elaborated Need	Guidelines
18	Accommodate 5th-95th world population	18.1	Have width of hand support that fits the world's population.	Width should be min 95,4 mm to fit a 95th percentile USA male. (Table 6.1)
19	Provide a reference point	19.1	Have horizontal support from housing when gripping a full handgrip high up on the handle.	Give support for hypothenar when gripping the handle
		19.2	Have vertical support from housing when gripping a precision grip further down on the handle.	Give support for palm when gripping the handle.
20	Allow hand support	20.1	Support hand when no handle action is needed.	To minimize the strain on the muscles it is important with micro breaks. The enabling of a resting position will achieve this effect.
		20.2	Support hand when it gets bumpy in the machine	Avoid possibility to unintentional move handle.
21	Follow chair / armrest	21.1	Be horizontal positioned in relation to armrest.	Enabled a good support from the armrest when the hand rests on the housing. (Widht)
		21.2	Be vertical positioned in relation to armrest.	Enable a good position between top of armrest and housing. (Height)

Table 10.4 Elaboration of ergonomic needs for buttons

Buttons				
	Needs		Elaborated Need	Guidelines
27	Be easy to distinguish between each other	27.1	To make it easier to separate the functions	Recommended button distance if no separation is used min 25 mm (Birt et al, 1996)
28	Be easy reachable	28.1	Enables to reach when the hand is placed on the housing.	Distance max 61.9 mm in order to be reached by a 5th percentile female from China's index finger length (Table 6.1).

## 10.2 Creation of functional prototype

When creating the physical prototype (*chapter 4.4.3*) it was important that it would be strong enough to be used in a wheel loader for two days, which created a demand on the material that the prototype was built in to be tough enough and that it would be possible to fasten all electronic components in it without it breaking.

### Creation of final layout of control unit

To fulfill the technical requirement existing buttons (*chapter 2.1.2*) had to be implemented and a control panel was added to the concept. The blue foam (*figure 10.1*) was used to try out the shape of the control panel and to fit the control panel to the housing. The final shape was built in the peach colored foam and the button placement was tried out (*figure 10.2*).



*Figure 10.1 Creation of the control unit*



*Figure 10.2 Layout for the buttons and switches.*

### Challenges

The joystick mounting had to be good enough to fulfill the demands testing and the housing therefore had to be remade from the mock-up. It was a challenge to mount the handle to the joystick base and a rigid mounting had to be constructed. The solution was to turn the diameter of the joystick stud and to thread it. In the handle a thin aluminum pipe was fastened and internally threaded (*figure 10.3*). This allowed the length to be adjusted if necessary and a contra nut fastened it to the joystick base.

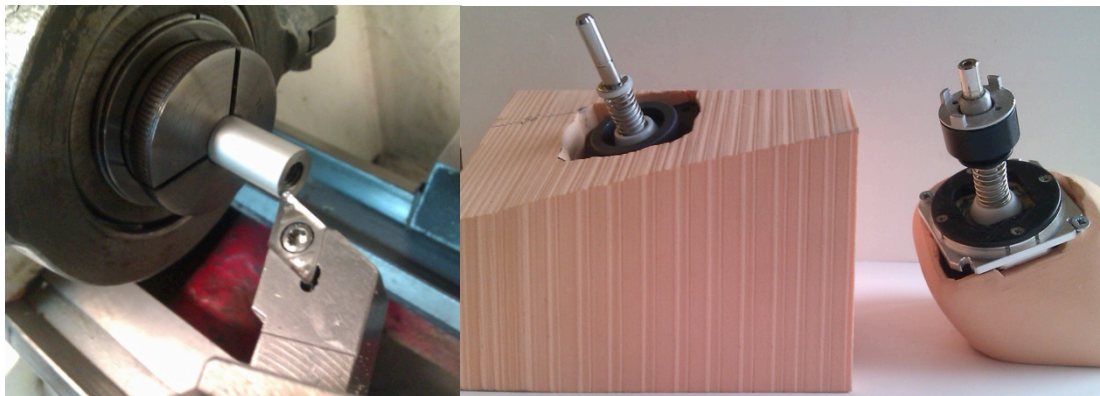

*Figure 10.3 Mounting of joystick base and handle.*



### Finished functional prototype

When the challenges had been solved all pieces were assembled and the splits were filled with spackling and sandpapered. The intention of the prototype (*figure 10.4*) was to be able to test it with users and it needed to facilitate as high functionality as possible. The foam is tough enough to be fastened with screws and buttons and switches can be steadily mounted. All these components were operational. Both the 3<sup>rd</sup> and 4<sup>th</sup> hydraulic functions could not be mounted in the prototype as the handle had a too small cross section and both sensors could not be fitted at this stage. To stay on schedule the handle had to be simplified to only consist of the sensor for the 3<sup>rd</sup> function and a dummy was used for the 4<sup>th</sup> function.



*Figure 10.4. The final prototype with mounted buttons.*

## 10.3 Detailed concept description

The major advantages with this concept are that all four functions (*Lift*, *Tilt*, 3<sup>rd</sup> and 4<sup>th</sup> function) have been integrated in one handle, the angle of the handle provides a grip closer to the natural position, the housing provides a reference point when controlling the handle and allows for a hand support, (need 3 and 4 in table 10.1 and need 19 and 20 in table 10.3).

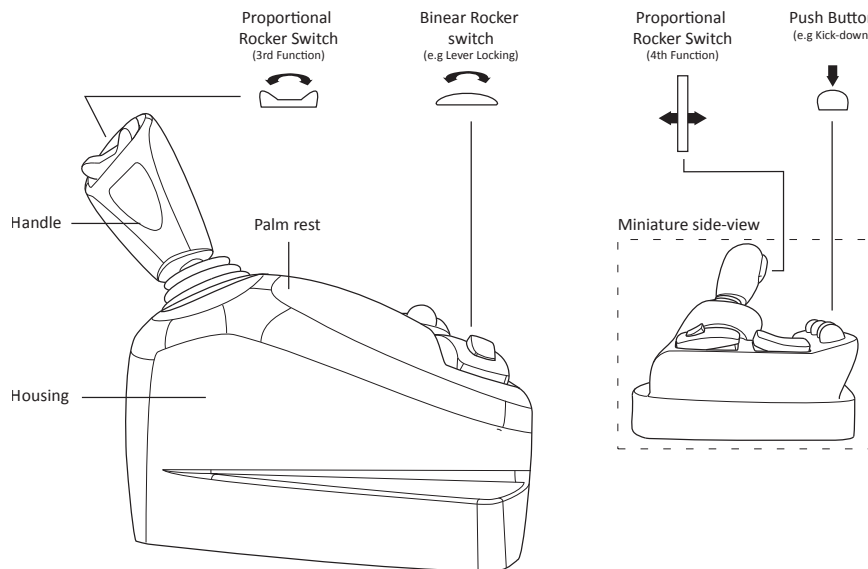

Figure 10.6 Overview

### Design choices for 3<sup>rd</sup> and 4<sup>th</sup> function

In this concept the 3<sup>rd</sup> function had been placed on top of the handle, controlled using the thumb, and the 4<sup>th</sup> function in the front of the handle, using the index and middle finger. This placement was found to be good when controlling the functions simultaneously and still have a good grip around the handle. The thumb is best used for side ways movements and therefore the shape of the 3<sup>rd</sup> function switch was designed as a cradle where the thumb can roll left to right (*Proportional rocker switch in figure 10.6*). The placement of the 3<sup>rd</sup> function on top of the handle is good to avoid unintentional activation of the function (need 6 in table 10.1). In order to fit the sensor for the 3<sup>rd</sup> function the switch was centered on the top surface, which gave a slightly unnatural thumb position when holding a power grip around the handle. The top surface was therefore tilted a bit towards the body's middle line to provide a more natural position for the thumb.

### Consequences of design choices for lift and tilt

A disadvantage with the integration of all four functions in one handle is that it can be hard to provide a natural mapping for all functions (need 9.1 in table 10.2), which is common for multifunctional controls. The primary functions, *lift* and *tilt*, are controlled using a joystick. *Lift* is controlled moving the handle in the machine's direction (parallel with the body's middle line). *Tilt* is controlled moving the handle perpendicular to the machine's direction (Towards and away from the body's middle line). The natural mapping of the *lift* function is as good as it can get using this technology. The natural mapping for the *tilt* function may not be as good as when using linear levers, however is the functions closely connected to each other and the usage of a joystick might make it



easier to control the functions simultaneously and for a novice operator to find the right balance between the functions when operating the machine, (need 8.2 in table 10.2).

The natural mapping (need 9.1 in table 10.2) is the most complicated to achieve for the 3<sup>rd</sup> and 4<sup>th</sup> function because of the variety of different attachments (chapter 2.1). No control can be optimized to fit all attachment. Most critical is the controlling of a two bladed snowplow where both functions are controlled simultaneously in relation to each other, (need 8.3 in table 10.2).

Because of the snowplow (need 8.3 in table 10.2) the 4<sup>th</sup> function should be controlled in the same direction as the 3<sup>rd</sup> function. To get a better grip of the 4<sup>th</sup> function the switch was designed as a tooth to not get in the way for the fingers while controlling it. The movement is not optimal for the fingers from an ergonomic point of view and the switch was therefore elongated so that it can be controlled using two fingers to divide the muscular load. The elongation of the switch also provides the possibility of vary the grip (need 5.1 in table 10.1) and makes it possible to fit small and large hands (need 1 in table 10.1).

## Handle

The angle of the handle was designed based on the guidelines in need 4.1 and 4.2 (Table 10.1). The angle towards the bodyline was set in the middle of the guideline's range to  $\alpha_1 = 40^\circ$  and the angle parallel to the bodyline was set to  $\alpha_2 = 20^\circ$  (figure 10.7).

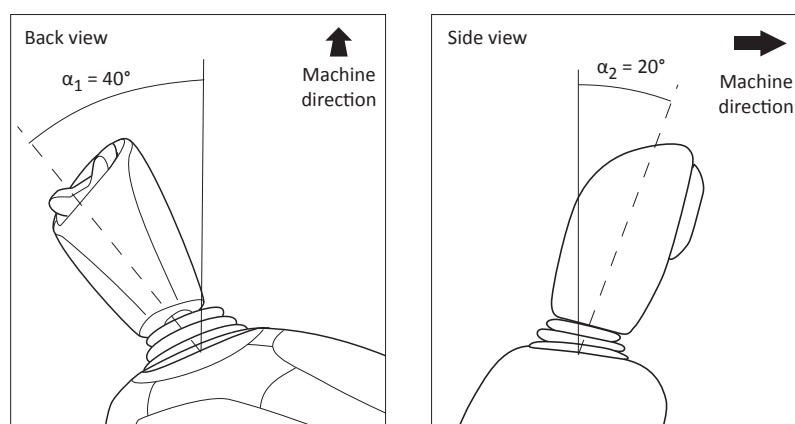

Figure 10.7 Angle of handle

When deciding the length of the handle there was two contradictory needs. The need of the 95<sup>th</sup> percentile to being able to hold a power grip around the handle and the need of a 5<sup>th</sup> percentile to being able to reach the 3<sup>rd</sup> function without losing the support from the housing (need 1.1 and 1.2 in table 10.1) - a difference in 29,5 mm. A compromise had to be made. Being able to hold a power grip might not be the necessary if the operator experiences a possibility of getting a good grip if there is enough support for the fingers. It would be enough if the 5<sup>th</sup> percentile can reach the switch with the top part of the thumb and the 95<sup>th</sup> percentile will probably get enough precision controlling the switch with the middle part of the thumb instead of the top. The top surface was therefore tilted in the machines direction (figure 10.8) – giving the front of the handle a length of  $L1 + L3 = 110$  mm to provide a support for the 95<sup>th</sup> percentile's fingers and a lower length of  $L2 + L3 = 85$  mm to provide an approximated reachability for the 5<sup>th</sup> percentile.

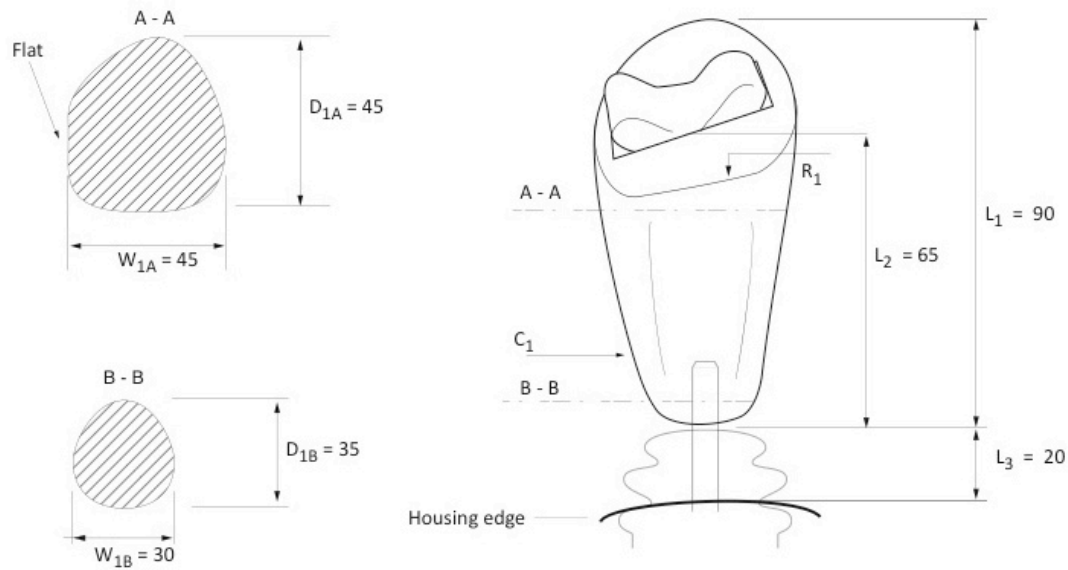

Figure 10.8 Handle

When deciding on the thickness there was also contradictory needs - thickness enabling a power grip and a precision grip (*need 1.3 and 1.4 in table 10.1*). When the operator needs higher precision it can be assumed that the operator also would need more support from the housing. Therefore the handle was given a conical shape – making it possible to hold a power grip higher up on the handle and a precision grip further down on the handle. There is however another need contradictory to the thickness of the handle the volume uptake of the sensors for the 3<sup>rd</sup> and 4<sup>th</sup> function (*need 17 in table 7.1 in chapter 7.2*). When using a joystick the cross section should be somewhat egg-shaped to give the operator a hint of the handle's direction (*need 10 in table 10.2*). The broadest width was therefore set to  $W_{1A} = 45$  mm and the thinnest with to  $W_{1B} = 30$  mm. The broadest depth was set to  $D_{1A} = 45$  [mm] and the thinnest depth to  $D_{1B} = 35$  [mm].

For the overall shape the handle has a slight curvature on the outer shape and the smooth surfaces to provide a comfortable grip, (*need 2.1 and 2.2 in table 10.1*).

## Housing

The housing is as have been mentioned previously a major importance in this concept. The important function of the housing is to provide a reference point when manoeuvring the handle (*need 19.1 and 19.2 in table 10.3*) and to allow a hand support to minimize the strain on the muscles and to avoid a possibility of unintentionally move the handle when it is bumpy in the machine (*need 20.1 and 20.2 in table 10.3*). The surface fulfilling these needs can be seen as S1 in *figure 10.9*. This surface is an interpretation of the needs and it has to be evaluated to see how well it actually fulfils the needs. The position of the housing in relation to the armrest also has to be evaluated and will probably need several hours of functional testing in a wheel loader before the exact measurements can be set. The only measurement that theoretically can be ergonomic correct set is the minimum width of the surface to the right of the handle;  $W_2 = 96$  mm (*need 18 in table 10.3*).

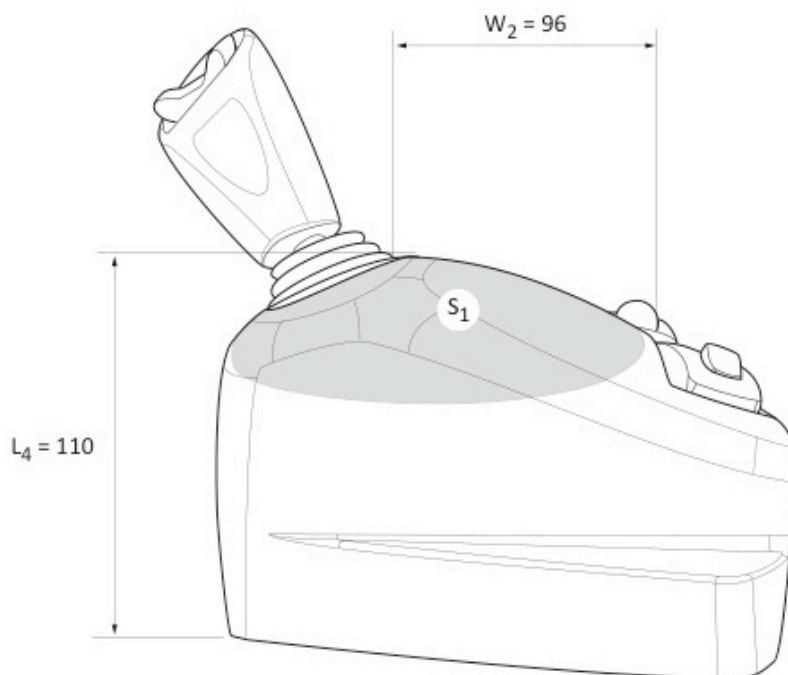

*Figure 10.9 Housing back view*

### Control panel (Buttons)

The additional buttons and switches (*need 29 in table 7.1 in chapter 7.2*) were placed on a separate control panel. The functions most important to reach while controlling the machine is *Kick-down* and *Engine break* and these were therefore placed closest to the handle (*figure 10.10*). The buttons were spread out to use all of the available surface and the distance  $W_3 = 40$  mm were used between the button's centerlines, which fulfill need 27 (*table 10.3*). For the 5<sup>th</sup> percentile being able to reach the buttons and to avoid the possibility to unintentionally activate any button function the distance was set to  $D_2 = 60$  mm. Since the control panel had not been developed in the previous concept generation phase it will be extra important to evaluate it during the concept evaluation.

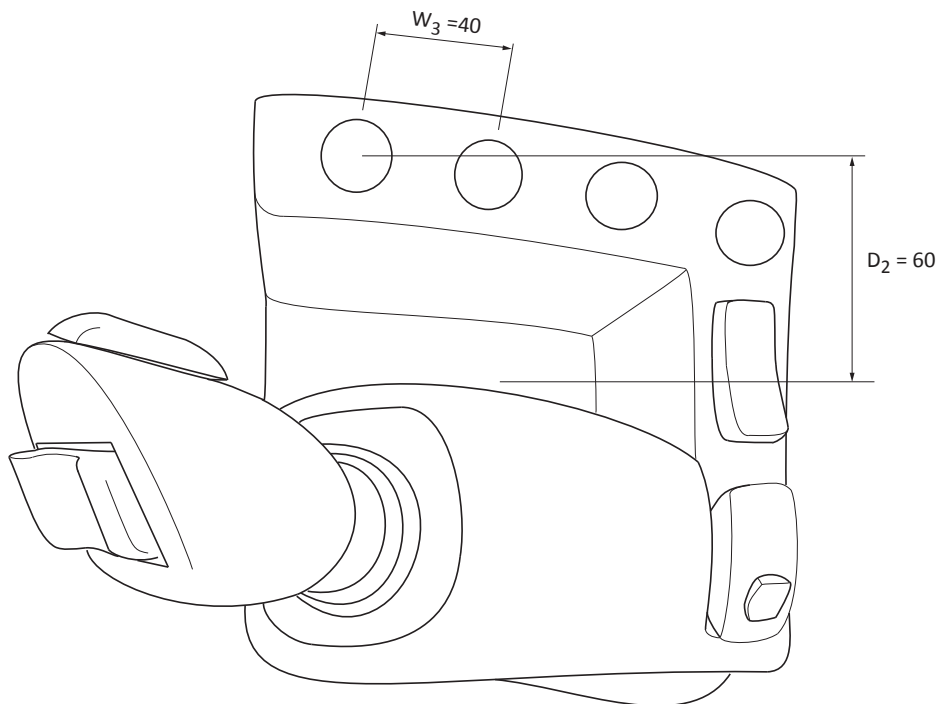

*Figure 10.10 Control panel*

# 11 Concept evaluation

*This chapter describes and concludes the extensive evaluation of the prototype developed in the previous chapter. Two wheel loaders were used with the concept called mini-joystick in one machine and an existing joystick that is available on the market, though not currently used in wheel loaders. The chapter gives results both subjectively with data from the participants, semi-subjectively by RULA ratings and objectively by a measuring the productivity.*

## 11.1 Execution of the evaluation

The evaluation was performed to find out if the concept could be compared to a standard joystick type. And if the prototype function good enough, would the concept it represents be preferred in comparison to an existing product?

The *mini-joystick* prototype were evaluated in relation to a standard joystick, so called *banana-joystick*. Seven participants from the reference group excavated gravel with two Volvo L180G wheel loaders and also filled a Volvo A35F dump truck for evaluating the ergonomic, functional and to an extent the aesthetic quality of the concept. Each participant started filling a wheel loader bucket with gravel for 20 minutes with the banana-joystick. Thereafter the mini-joystick was tested for another 20 minutes. The two wheel loaders were equipped with 4 cameras each; angled to film hand postures from side and from above; filming arm posture; and forward filming the bucket.

### 11.1.1 Participant measurements

The stature, weight, hand length and hand width were measured in order to see the deviation of the group compared to normal distribution. The reference groups length and hand sizes correspond to the 45<sup>th</sup> to 95<sup>th</sup> percentile compared to the North European population (Dined, 1989) and 60<sup>th</sup> to 95<sup>th</sup> percentile compared to an international population (Dined, 1989). In order for the reference group to simulate the world population a correspondence of 5<sup>th</sup> to 95<sup>th</sup> percentile is needed. However, this was impossible to fulfill, but taken into consideration when the evaluation was concluded.



*Figure 11.1 Mini-joystick*



*Figure 11.2 Banana-joystick*

### 11.1.2 Execution of methods

Videos recordings from the cameras inside the machines defined participants' hand postures. The observations followed a developed protocol to note observed actions, see *appendix V*. Observed postures were analyzed semi-objectively with RULA (*Chapter in 4.2.5*) and for objective analysis with measuring the cycle time of a short loading cycle. The subjective analysis was done by transcribing the interviews and summon answers from questionnaires.

#### **Measuring loading cycle**

The short loading cycle of the dump truck had following steps; 1) excavating the gravel from the pit; 2) backing out from the pit; 3) turning and driving forward to get to the dump truck; 4) emptying the bucket and 5) backing away from dump truck. A simple stopwatch measured the time. Time was started and stopped at the start of the first step; the excavating of gravel from the gravel pit.

#### **Rapid Upper Limb Assessment**

This method cannot be regarded fully objective, but the rating give a hint of the ergonomics within the scope of the method. The result is semi-objective and was in this evaluation used together with the observations in order to triangulate for making conclusions. The postures were analyzed based on the theoretical framework for this project. The most extreme postures, good and bad of each concept was noted and rated by the RULA method Selected body regions chosen in the study were:

- Upper arm position (angle around shoulder joint in the sagittal offset plane)
- Fore arm position (elbow angle in the sagittal offset plane)
- Wrist position (flexion or extension)
- Wrist bending (radial deviation or ulnar deviation)
- Forearm rotation (pronation or supination)

The movements are described in detail in figure 3.3. The ratings were set to values ranging from -2 to +2 depending on the magnitude of movement or angling away from neutral position, where 0 was set if angle lied close to the neutral. Wrist extension, radial wrist deviation and forearm supination gave positive figures. Neutral angle in shoulder joint was considered as 0° with upper arm pointing down. Neutral angle between the forearm and elbow was at 90° angle, see *appendix V* for complete overview of ratings of postures.

Normally a score of 0 is considered better ergonomics in RULA evaluations. However, as RULA is developed for power lifts, the predefined preferred lower arm rotation is a position between pronation and supination, in a “handshake position” (figure 3.3). As the joystick work is not about lifting, but instead having the forearm close to neutral position, the preferred position is a small pronation. This is compensated in the evaluation by setting the score of -1 as the best posture when calculation an average score (\* in table 11.2).

## Subjective analysis

The participants filled out a questionnaire after each machine test and were interviewed afterwards in addition to the questionnaire. The semi-structured interviews were performed to understand why the participants answered the way they did and to gather feedback for further development. The mini-joystick was the primary focus in the evaluation and the banana-joystick was used as a reference product. Therefore feedback was not collected from the banana-joystick. The questionnaire were using the Likert-scale (*Chapter 4.1.2*) on the following questions:

- **Overall**  
Q1 - How comfortable do you think the control lever is?
- **Size and shape**  
Q2 - How do you experience the thickness of the lever?  
Q3 - How do you experience the length of the lever?
- **Placement**  
Q4 - What do you think about the placement of the third function?  
Q5 - What do you think about the placement of the fourth function?  
Q6 - What do you think about the placement for kick-down, engine break, etc.?
- **Function**  
Q7 - How do you consider the feeling in the lever, regarding on the spring force?  
Q8 - How do you consider the feeling in the lever, regarding the stroke length?

## 11.2 Results

Objective results are made from observation of a measuring the loading cycle. The semi-objective analysis is described together with an analysis of the worst hand postures taken from the videos. Subjective answers are gathered in charts and a selection of comment from each elaborated question is described. The thorough data-collection of the evaluation is not described to the full.

### 11.2.1 Cycle time comparison between the two concepts

Only one participant could be tested when comparing the cycle time for the two joysticks, but the participant improved his time with the mini-joystick (*table 11.1*). The participant did not have extensive experience driving with a single lever and tested the banana-type of lever first.

*Table 11.1 Measured loading cycles*

	Banana-joystick	Mini-joystick
<b>Number of measured cycles</b>	9	9
<b>Mean time (seconds)</b>	31	27

## 11.2.2 Posture observations

This chapter gives examples of the worst postures found for the mini-joystick, but also on the ergonomic benefits. The grips of the joysticks were of great influence of the postures. The same observations were made for the banana-joystick and the summoned result sis presented in a table (*table 11.2*) with RULA ratings.

### Handgrips

Primarily loose handgrips were preferred by the participants in both concepts and the fingers and even fingertips are handling most of the maneuvering. The mini-joystick provided a form that the participants grip in three major ways, defined as: first a *full hand grip* around the handle; secondly a lower grip *also gripping housing*; and thirdly a *full grip with thumb* in thumb switch (*figure 11.3*).

### Observed improved postures with mini-joystick

The mini-joystick concept seemed to improve the physical ergonomics compared to current products and also compared to the reference joystick. The hand and wrist were to large extent mostly kept close to the neutral positions. This was observed for all participants and all handgrips used. *Figure 11.4* shows a screen shot from the observation and shows a posture resulting good ratings also with the RULA method.

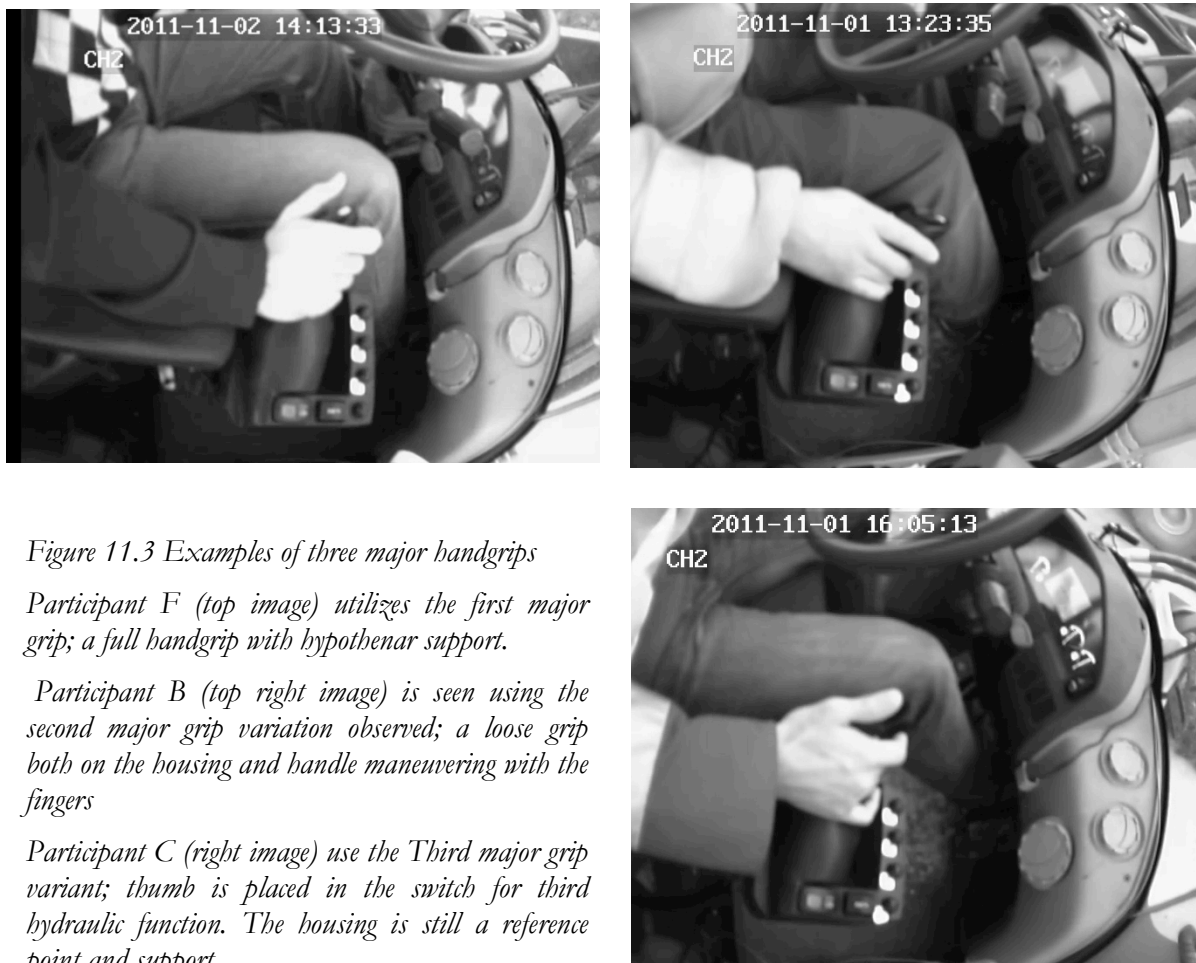

*Figure 11.3 Examples of three major handgrips*

*Participant F (top image) utilizes the first major grip; a full handgrip with hypothenar support.*

*Participant B (top right image) is seen using the second major grip variation observed; a loose grip both on the housing and handle maneuvering with the fingers*

*Participant C (right image) use the Third major grip variant; thumb is placed in the switch for third hydraulic function. The housing is still a reference point and support.*





*Figure 11.4 Participant E*

*This is an example screenshot of all four camera-angles on the mini-joystick prototype. The participant is in this case using a full handgrip, but the screenshot is representative for the neutral postures of the concept. Each observed participant had an individual grip, just as the early observations showed, in the analysis of the current control levers.*

### **The mini-joystick used as support**

Another positive ergonomic feature of using the housing as a support could be observed on several participants. And on comparison, several participants were observed to completely release the grip on the Banana-joystick when the wheel loader was exposed to large vibrations, this is seen best in *figure 11.5*. But as seen in the *figure 11.6*, the mini-joystick provided a firm gripping of the housing.

### **Observed ergonomic issues of the mini-joystick use**

In some situations and for some participants, the full handgrip (first grip type) tends to induce an extension in the wrist. When pulling the joystick backwards for doing *lift* function, the wrist was extended to perform full movement (*figure 11.7*). When some participants tilted up the bucket with full speed, the joystick was rotated to the maximum right. This induced the worst wrist bending for the mini-joystick; a slight deviation if holding on housing and handle, defined as the second grip type (*figure 11.8*). Using the third grip type seems to adopt combinations of the above-mentioned deviation and extension of the wrist, but not as badly.



*Figure 11.5 Participant F*

*When operating the wheel loader during large vibrations, the subject is observed realising the grip of the joystick.*



*Figure 11.6 Participant G*

*When operating the wheel loader during large vibrations, the subject is observed gripping the mini-joystick housing.*



*Figure 11.7 Participant F*

*A larger extension than preferred, could be observed when the subject used the first, full handgrip around the handle and lifting the bucket.*



*Figure 11.8 Participant C*

*This subject uses the second grip type, showing a slight deviation when fully tilting up*

### 11.2.3 Rapid Upper Limb Assessment

The mini-joystick seemed to have better ergonomics with a lower score of 1.75, the standard-type of 2.63 (*table 11.2*). The wrist extended positions differed as much between the participants as the concepts. The deviation tends to be greater with the banana-joystick; probably an effect of users maneuvers the joystick with the fingers tips.

*Table 11.2 RULA scores for the two concepts*

Participant	A		B		C		D		E		F		G	
	BANANA	MINI	BANANA	MINI	BANANA	MINI	BANANA	MINI	BANANA	MINI	BANANA	MINI	BANANA	MINI
Upper arm position	0	0	0	0	0	0	0	0	0	0	0	0	0	0
Lower arm position	-1	-1	-1	-1	-1	-1	-1	-1	-1	-1	-1	-1	-1	-1
Wrist position	0	2	1	0	1	0	1	0	0	1	0	2	1	1
Wrist bending	0	0	1	0	0	0	0	0	0	0	1	0	1	0
Forearm rotation	1	-1	1	-1	1	-1	2	-2	1	-1	1	-1	0	-1
Absolute sum	2	4	4	2	3	2	4	3	2	3	3	4	3	3
Compensated sum for pronation*	2	3	4	1	3	1	4	2	2	2	3	3	3	2

Mean RULA score

Banana-joystick:	2,63
Mini-joystick:	1,75

### 11.2.4 Subjective analysis

The answers from the questionnaire were summoned both as how each participant answered and also aggregated as how the two concepts were compared to each other. The interviews revealed more information on why the participants had answered as they did. Some comments from these interviews are transcribed in this chapter. The subjective analysis gave input for the improvements to make for a final concept. For more detailed description and overviews of the answers, see appendix: The elaboration of each question and the median values is available in *appendix VI*. This also shows transcriptions of the subjects' answers from the semi-structured interviews. The result for each question is seen in *appendix VII*. How each participant answered is seen in *appendix VII*.

#### Comparison between the mini-joystick and standard joystick

The comparison was made from the median value of the Likert-scale for each question of the questionnaire. The aggregated results from the questionnaire are seen in *chart 10*. A question of the preferred joystick is seen in *chart 9*. The mini-joystick was the most desired joystick in comparison with the standard type.

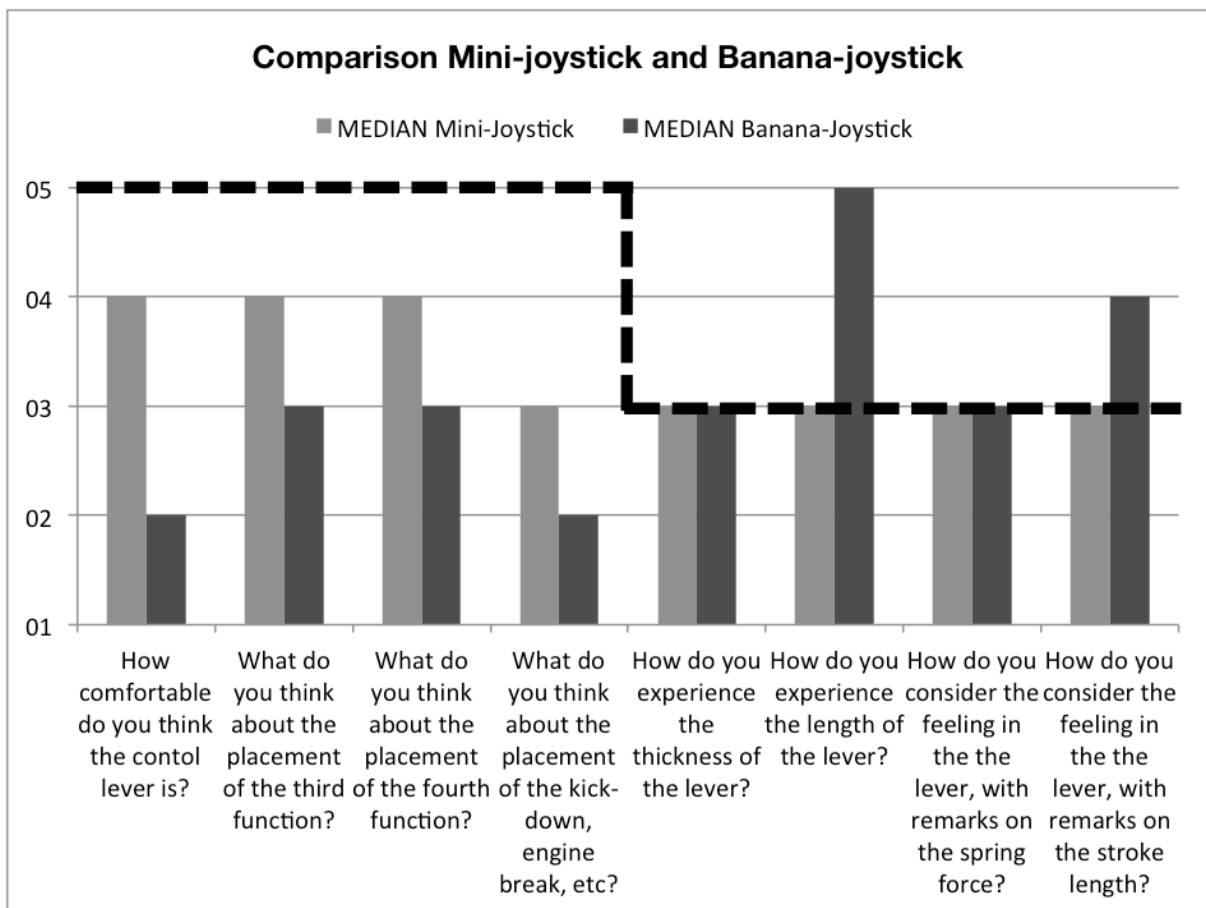
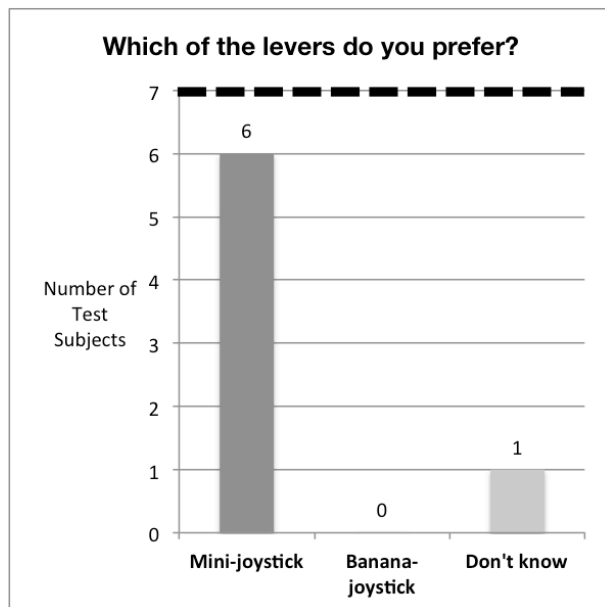

*Chart.10 Comparison of the joystick types*

*Participants' answers' median value from the questionnaire are compared for each question and concept. The green line describes the preferred values on the Likert-scale.*

### General comments from the evaluation

Some of the participants commented that it was a little bit hard to reach a good driving feeling due to the inexperience of controlling a single lever. But with some training these participant believe that it would be possible to operate the machine with a single lever. Some of the participants commented that the mini-joystick was surprisingly easy to operate for being a first prototype. Most participants commented that the mini-joystick is much more pleasant to operate with compared to the banana-joystick - this due to the shorter handle length, shorter stroke and the better support that the mini-joystick housing provides. Six out of seven preferred the mini-joystick compared to the banana-joystick, see *chart 9*. The seventh participant could not decide which joystick he preferred.



*Chart.9 Preferred joystick*

### **Comments on questions Q1**

All participants liked that the joystick was angled. Two participants thought that it was a little bit too much angled inward (5°-10°). They said that the lever might touch the operator's leg at full stroke length inwards.

### **Comments from question Q2 and Q3**

Some participants said that the handle was a little bit too thick when only using the thumb and index finger. They would like it to be a little bit thinner (5mm-10mm) at the bottom of the handle. All participants liked the length of the handle.

### **Comments from question Q4 and Q5**

Most participants liked the placement of the 3<sup>rd</sup> *function*. One participant suggested that the 3<sup>rd</sup> *function* could be placed on the base instead. Most participants liked the placement of the 4<sup>th</sup> *function*. Some wanted it to be placed a little bit further down on the handle

### **Comments from question Q6**

The control panel was regarded placed too far away from the handle. When asking the participants where they would like to place the buttons most wanted to place the kick-down button on the handle (where the 4<sup>th</sup> *function* is placed) or on the housing. Most participants said that the direction selector was placed too far away. They would like it to be placed on the housing closer to the hand instead.

### **Comments from question Q7 and Q8**

Two participants said that the spring force was too low. One of them said that he had to stretch his hand in order to control the lever. One participant wanted to have features in order to separate the functions better, something to enhance the feel of using one or both hydraulic functions. Some participants mentioned that it was a bit hard to fine tune the *lift* and *tilt* function, especially the *lift* function. The participants thought that this could be either because of the spring force or because of the joystick characteristics in the software. Some participants said that they experienced a delay in the machines movement; they wanted a quicker response. Overall the participants found it hard to imagine how the hold functions could be designed. The suggestions were to have a detent mode where the joystick-position would be locked; to have a pre-feeling mode where the hold function was activated or to have separate buttons to activate each hold-function.

## 11.3 Conclusion of the evaluation

*The evaluation was aimed to answer: is the mini-joystick concept is preferable in regard of a single lever?*

Objectively the mini joystick was evaluated to be a better ergonomic choice than the banana joystick. This is due to the wrist deviation that tends to be bigger with the banana-joystick, an effect of maneuvering the joystick with the fingers tips. The grip is an important factor for the wrist and arm movements as described later in the pictures found in the document. The mini-joystick is better designed for loose grips (where fingers are mostly used) as the hand is more statically placed only requiring small movements and almost no fore arm movements are induced. The exception, when using a full grip, can be improved ergonomically if the mechanical angle, or stroke, is reduced. When measuring short cycle time the mini-joystick seems to improve the cycle time. This conclusion is not statistically verified due the nature of this short test, but this indicates a potential in the concept. Mostly the deliberate pronation and minimized fore arm movements in the mini-joystick, is the biggest advantage for the mini-joystick concept.

Subjectively, most favorable concept is considered the mini-joystick. Mostly the participants used the housing as a reference support when using the lever and they could rest their hand against the housing to prevent unwanted lever movements during bumping conditions. Shape and size of the handle is regarded better in the mini-joystick, but the handle could be made a little bit thinner – especially in the bottom. The placement of the 4<sup>th</sup> function (and somewhat 3<sup>rd</sup>) switches has to be evaluated again with new models, as there were comments on this, even if the placement in general were approved. Important to note is that the switches were dummies that only represented a conceptual placement and were not intended to be tested in the same level of functionality as *lift* and *tilt*. Input regarding buttons suggest that the kick-down, engine break and direction selector could be placed on the housing instead. More thorough testing of the machine response and higher spring resistance with the mini-joystick should be carried out. These two features are related to each other. The machine response was not calibrated or tuned with the joystick base previous this evaluation.

### 11.3.1 Improvements to take the prototype to the next level

The conclusion from the evaluation was clear. To concretize the evaluation into something useful for the further development, improvements to make are stated below. A lot of data from the evaluation was discussed and sometimes participants' suggestions were used almost directly for the improvements.

#### **Improvements to the housing and control panel**

- Add softer material to the housing surface that the hand is resting against, e.g. PUR – the same material that is used on the armrest.
- Increase the vertical hand support from the housing towards the handle.
- Reduce the distance between the control panel and the housing or place the buttons from the control panel on the housing.
  - Move Kick-down, Engine break, Signal horn and Direction selector to the housing.

#### **Improvements to the handle**

- Softer edges of transition between surfaces.
- Reduce the thickness in the bottom of the handle (If possible reduce the thickness all-over).
- Place the 4<sup>th</sup> function a little bit further down, possibly replacing it with a vertical proportional rocker switch.

#### **Improvements to the Joystick**

- Increase the spring force a little bit.
- Introduce a pre feeling (a force index) at the end of the stroke length.
- Optimize the machine's response to better fit the movement of the joystick
  - Less machine movement close to the neutral point, accelerating with longer strokes.



# 12 Final concept

With the input from the concept evaluation the list of needs was updated (chapter 12.1). The final concept was redesigned to fulfill the new needs and all technical limitations (table 7.1 and table 7.2) were taken in consideration to make the final concept as feasible as possible. A new but non-functional prototype was developed (chapter 12.2) and the final concept is described in detail (chapter 12.3). The concept was evaluated one last time using the reference group (chapter 12.4) and a final reflection of the concept was made (chapter 12.5).

## 12.1 Elaborated needs from chapter 10.1

The concept evaluation resulted in new input about the concept and the list of needs (chapter 10.1) therefore had to be elaborated further. Some of the existing needs and guidelines were redefined and new needs and guidelines were added to the list. The elaborated needs related to the handle can be seen in table 12.1 and 12.2. The elaborated needs related to the housing can be seen in table 12.3 and the elaborated needs for the buttons can be seen in table 12.4.

Table 12.1 Elaboration of physical ergonomic needs for the Handle

Handle - Physical Ergonomics				
	Needs		Elaborated Need	Guidelines
1	Suit 5th to 95th percentile of the world population.	1.1*	Have length enabling a power grip.	Length L1+L3 should be min 95,4 to fit the 95th percentile of a USA male's handbreadth. (Table 6.1)
		1.2*	Have length enabling reach for 3 <sup>rd</sup> function	Length L2+ L3 should be max 65,9 + (length of thumb) mm to fit the 5 <sup>th</sup> percentile of a Chinese female's handbreadth. (Table 6.1)
		1.3**	Have as thin thickness as possible.	Min thickness depends on the volume uptake of the sensors for the 3 <sup>rd</sup> and 4 <sup>th</sup> function.
2	Provide comfortable grip.	2.1	Have good overall shape.	Handles used in gripping should have a slight curvature to follow the shape of the hand. (Haslegrave & Pheasant, 2006)
		2.2	Have good detailed shape	Sharp edges should be avoided to eliminate force hotspots (finger grooves, handle shapes etc.) (Haslegrave & Pheasant, 2006)
		2.3*	Have softer edges between transition surfaces.	Recommended min radius 25 mm. (Haslegrave & Pheasant, 2006)
3	Allow reachability of lift, tilt, 3 <sup>rd</sup> and 4 <sup>th</sup> function without changing grip.	3.1	Integrate 3 <sup>rd</sup> and 4 <sup>th</sup> function in handle.	Avoid using fingers connected with the same extensors for different controls. Lift and tilt controlled with fingers or the whole hand. 3rd function controlled with thumb. 4th function controlled with middle/ index finger.
		3.2*	Have good distance between 3 <sup>rd</sup> and 4 <sup>th</sup> function.	Evaluation revealed that 4 <sup>th</sup> function should be moved further down, still keeping a natural grip. Further evaluation is necessary.
4	Provide a grip close to the natural position.	4.1*	Enable a natural forearm position.	Previous angle 40° towards the bodyline should be straighten up 5-10° to avoid handle touching the operator's knee.
		4.2	Enable a natural hand position.	A handle used for power handling should have 20° parallel with the bodyline to shape after the finger lining when gripping. (Gilbert et al, 1988)
5	Provide variation	5.1**	Enable a full	The usage of different grips will divide the muscular

	of grips.		handgrip.	stress on several muscles, which will reduce the risk of Cinderella hypothesis. Need 5.1 relates to need 1.1 and 19.1. Need 5.2 relates to need 1.2. And 19.1. Need 5.3 relates to need 1.3 and 19.2.
		5.2**	Enable a full handgrip with thumb in 3 <sup>rd</sup> function switch.	
		5.3**	Enable a grip further down on the handle getting more support from the housing.	
6	Avoid unintentional activation of functions.	6.1	Enable a good design of switches.	Avoid possibility of getting caught with something in the switches.
		6.2	Enable activation/inactivation of function.	Have a possibility to activate and deactivate electric signal to handle.

\* Updated need

\*\* New need

Table 12.2 Elaboration of cognitive ergonomic needs for the Handle

Handle – Cognitive Ergonomics				
	Needs		Elaborated Need	Guidelines
7	Be able to slowly and precisely control the hydraulics.	7.1	Have proportional characteristics (All four functions).	No recommendations are available for recommended stroke length. Evaluation in machine is necessary for all four functions.
		7.2	Enable a good grip of switches.	The switches should either be in a high friction material or have ribs or grooves in the shape to increase the friction.
		7.3**	Have a good level of resistance in the joystick.	The resistance should be high enough to provide a precise control of the handle but not be too high so that a strain is put on the muscles.
		7.4**	Have a good resolution between the machine response and the handle's movement.	Suggestion of less machine movement close to the handle's neutral point, accelerating with longer strokes. Needs to be evaluated further.
8	Allow simultaneous use of functions.	8.1	Amount of functions controlled.	Max 4 control mechanisms located on the same control.
		8.2	Simplify balance between Lift and Tilt for a novice operator.	The usage of a joystick gives an advantage of controlling two functions with one single movement.
		8.3	Control of a two bladed snowplow.	The 3 <sup>rd</sup> and 4 <sup>th</sup> function has to be able to be controlled in the same way and in relation to each other. They should therefore be controlled in the same direction.
		8.4**	Simultaneous use of 3 <sup>rd</sup> and 4 <sup>th</sup> function together with lift and tilt.	The ability of controlling the functions simultaneously has to be evaluated in machine tests using various attachments.
9	Provide natural mapping.	9.1	Provide a good direction of control.	The movement of the controls in relation to their neutral position shall be in the same general direction as the machine response.
10	Give users hint of directions of the handle.	10.1	Have an intuitive shape.	The cross section of a handle should be somewhat egg-shaped to set the direction of the handle. (Hägg et al, 2009)

\* Updated need

\*\* New need

Table 12.3 Elaboration of physical ergonomic needs for the Housing

Housing – Physical ergonomics				
	Needs		Elaborated Need	Guidelines
18	Accommodate 5th-95th world population	18.1*	Have width of hand support that fits the world's population.	Width W2 should be min 95,4 mm to fit a 95th percentile USA male. (Table 6.1)
19	Provide a reference point	19.1*	Provide a reference point when gripping a full handgrip high around the handle.	Housing should give support for hypothenar when gripping a full hand grip around the handle
		19.2*	Provide a reference point gripping further down on the handle.	Housing should give a <i>palm rest</i> when gripping the handle. Evaluation revealed that the form should be more bulged up to increase the support.
20	Allow hand support	20.1	Support hand when no handle action is needed.	To minimize the strain on the muscles it is important with micro breaks. The enabling of a resting position will achieve this effect.
		20.2	Support hand when it gets bumpy in the machine	Avoid possibility to unintentional move handle.
		20.3*	Provide a softer material on the surface where the hand is resting.	E.g. use PUR - the same material used on the armrest.
21	Follow chair / armrest	21.1	Be horizontal positioned in relation to armrest.	Enabled a good support from the armrest when the hand rests on the housing. (Width)
		21.2	Be vertical positioned in relation to armrest.	Enable a good position between top of armrest and housing. (Height)
		21.3**	Provide adjustability between housing and armrest.	Adjust distance between housing and armrest. Adjust rotation of housing.
* Updated need				
** New need				

Table 12.4 Elaboration of ergonomic needs for buttons

Buttons				
	Needs		Elaborated Need	Guidelines
27	Be easy to distinguish between each other	27.1	To make it easier to separate the functions	Recommended button distance if no separation is used min 25 mm (Birt et al, 1996)
28	Be easy reachable	28.1*	Enables to reach when the hand is placed on the housing.	Distance D2 max 61.9 mm in order to be reached by a 5th percentile female from China's index finger length. (Table 6.1) Evaluation revealed that D2 has to be measured from the centerline of the handle instead.
* Updated need				
** New need				

## 12.2 Redesign of prototype

The main changes that had to be made to the handle was to build in the sensors for the 3<sup>rd</sup> and 4<sup>th</sup> function in the handle (need 17, table 7.1), find a good distance between the sensors (need 3.2, table 12.1) and soften the edges on the handle (need 2.3, table 12.1). The main changes that had to be made to the housing were to increase the support for the palm (need 19.2, table 12.3), redesign the outer shape of the housing to fit an existing plastic lower cover (need 26, table 7.2) and reduce the distance between the buttons and handle (need 28.1, table 12.4).

### Handle

The toughest challenge for the handle design was to fit the sensors and still keep a thin shape. Several prototypes of the handle were built to try out different solutions (figure 12.1).

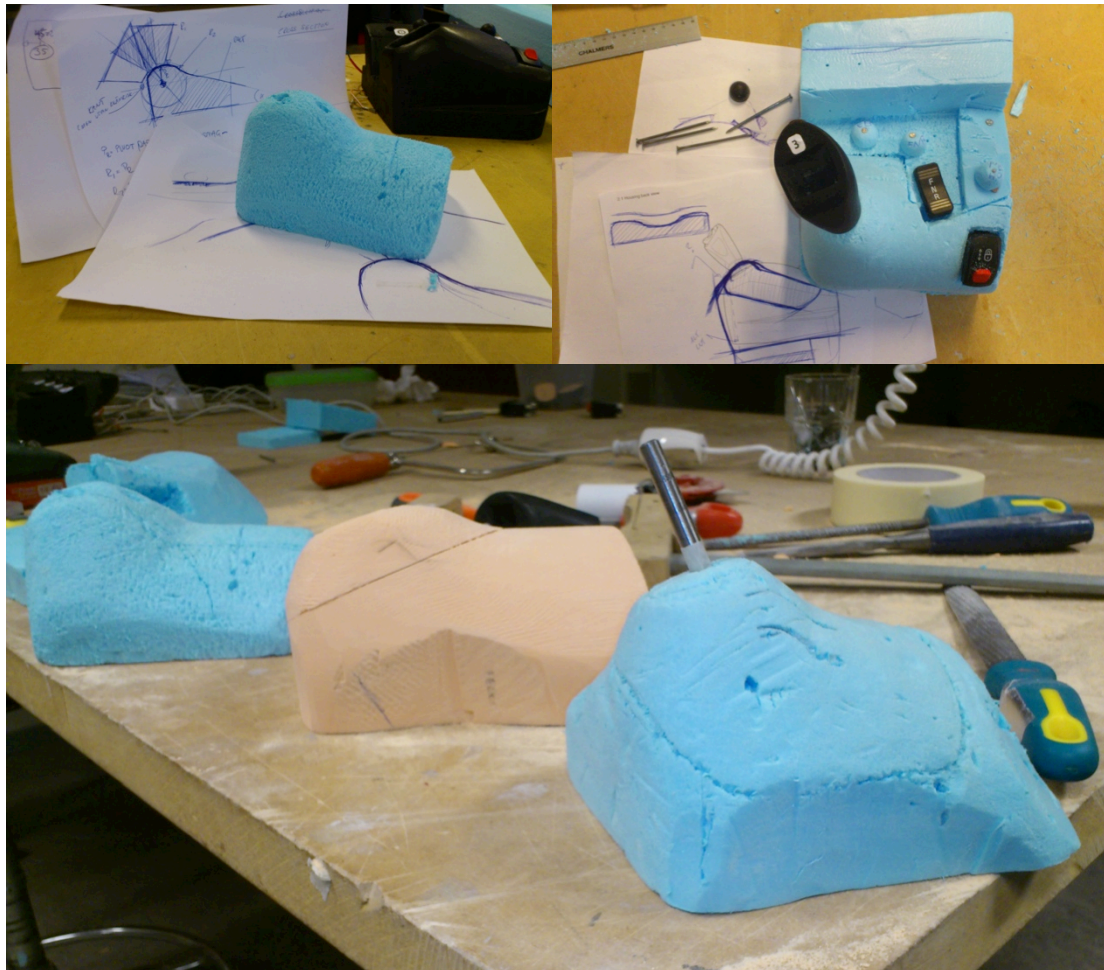

Figure 12.1 Creation of handle

*In the top left there are three prototypes with different solutions on several aspects. The leftmost has the sensor angled in 90° in order to test another configuration. The idea is tested, seen to the top right but had to be opt out because of the large distance between the two sensors. In the bottom right the handle is close to a good grip, but the surface in front of the thumb is too flat giving a too straight position for the thumb an that concept also had to be opt out.*

## Housing

To meet the technical limitation of fitting the housing to the lower plastic cover (*need 26, table 7.2*), the control panel and housing was combined. This integration opened up new possibilities for how the buttons can be placed. The toughest challenge for the housing was to design the palm rest. The input from the concept evaluation (*chapter 11*) was to make the form more protrude to increase the support of the palm when gripping or resting on the housing (*need 19.2, table 12.3*), but will the amount of needed protruding be different for the 5<sup>th</sup> and 95<sup>th</sup> percentile. Two different foam mock-ups were therefore created to evaluate the shape before the actual prototype was made (*figure 12.2*).



*Figure 12.2. Creation of palm rest*

*The peach colour foam was shaped to a compromise between the two blue forms. The form protrude to function as a palm rest for a variety of grips, both give hypothenar support, full palm rest support during large vibrations and for everything in between. On the top right image an early layout for the buttons are visible.*



When a good shape for the palm rest had been found the overall shape had to be fitted to the lower plastic cover and to the armrest. The prototype rig (*chapter 4.4.2*) was used to evaluate the size and proportions (*figure 12.3*). The aesthetic form development was not the primary focus, however did the overall shape feel clunky together with the lower plastic cover and the front surface of the housing was chamfered to give a sleeker look.



*Figure 12.3 Creation of housing*

*In the upper image the housing is fitted to the lower plastic cover. In the lower left image the height of the housing and the relation between the housing and handle is evaluated. In the lower right image the main shape of the housing have been set.*

### Finished prototype

The prototype represents the concept and is made for validation of the concept. It is not fully functional, but facilitates electronic sensors for 3<sup>rd</sup> and 4<sup>th</sup> function and a joystick base for the *lift* and *tilt* function. Also, buttons and switches are mounted in positions, and the form fits existing mounting brackets, so the construction is possible to be machined further for full functionality, if needed.



*Figure 12.4 the finished physical prototype*

## 12.3 Detailed concept description

In the final concept the technical limitations have been taken in consideration to increase the feasibility of the concept. The 3<sup>rd</sup> and 4<sup>th</sup> function have been mounted in the handle and the housing have been fitted to the lower plastic cover. The new and the redefined needs, based on the input from the concept evaluation of the first prototype, have been implemented to enhance the ergonomic validity of the final concept.

### Handle

In the concept evaluation it was revealed that the handle might touch the operators knee if being too angled towards the middle line (*need 4.1, table 12.1*) and the angle was therefore changed to  $\alpha_1 = 30^\circ$  (previous  $40^\circ$ ). The angle towards the machine direction was kept the same as in the previous prototype (*need 4.2, table 12.1*),  $\alpha_2 = 20^\circ$  (*figure 12.5*).

The tough challenge of fitting the sensors of the 3<sup>rd</sup> and 4<sup>th</sup> function required some compromises being made to the shape of the handle. To achieve a good support for the thumb when controlling the 3<sup>rd</sup> function the sensor had to be placed centered in handle. To fit the sensor for the 4<sup>th</sup> function without it being placed too far down, (*need 3.2, table 12.1*) on the handle both sensors had to be mounted in right angles. Because of the right angles the top surface could no longer be angled towards the body's middle line, which might give a slightly unnatural thumb position when holding a full hand grip (*need 5.2, table 12.1*). However the non-angled surface does provide a better natural mapping for the 3<sup>rd</sup> function (*need 9.1, table 12.2*).

Even with the sensors mounted straight the 4<sup>th</sup> functions ended up quite far down on the handle. As in the previous prototype the 4<sup>th</sup> function switch was elongated – making it possible to control it using two fingers, dividing the muscular load. To improve the reachability when using the 3<sup>rd</sup> and 4<sup>th</sup> function simultaneously (*need 8.3, table 12.2*) the 4<sup>th</sup> function switch was elongated upwards, reducing the distance to the 3<sup>rd</sup> function (*need 3.2, table 12.1*). To provide an ability of precisely control the hydraulics, enabling a good grip of the 4<sup>th</sup> function switch (*need 7.2, table 12.2*) the tooth shape from the previous prototype was further developed into a combination of half a scroll-wheel (rounded) and half a tooth (*figure 12.6*). The rounded part should be used for pushing the switch and the tooth part for pulling the switch.

To make sure that the 5<sup>th</sup> percentile would be able to reach the 3<sup>rd</sup> function (*need 1.2, table 12.1*) the handle was mounted closer to the hosing,  $L_3 = 15$  mm (Previous 20 mm), giving a total length to the 3<sup>rd</sup> function being  $L_2 + L_3 = 80$  mm. To provide a more comfortable grip the edges was made softer (*need 2.3, table 12.1*), especially on the top surface. The softer edges resulted in the front of handle being a bit shorter,  $L_1 + L_3 = 95$  mm (previous 110 mm) which is acceptable for the 95<sup>th</sup> percentile being able to hold a full handgrip (*need 1.1, table 12.1*).

The need of making the handle thinner (*need 1.3, table 12.1*) was not easy to accomplish because of the volume uptake of the sensors for the 3<sup>rd</sup> and 4<sup>th</sup> function. However because of the straight mounting of the 3<sup>rd</sup> function sensor it was possible to reduce the broadest width to  $W_{1A} = 40$  mm (Previous 45 mm). The cross-section is still egg-shaped (*need 10.1, table 12.2*) to give the operator a hint of the direction of the handle



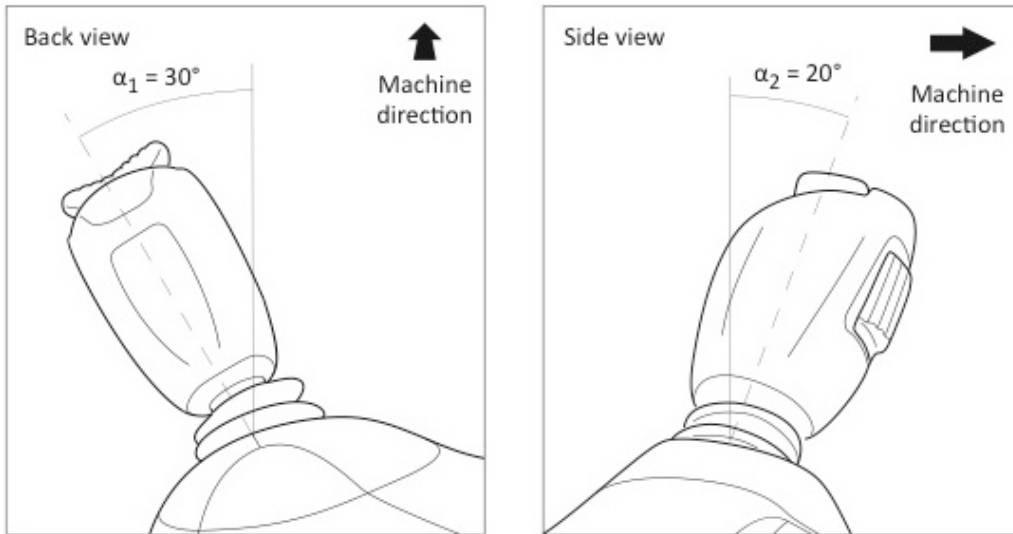

Figure 12.5 Angle of handle

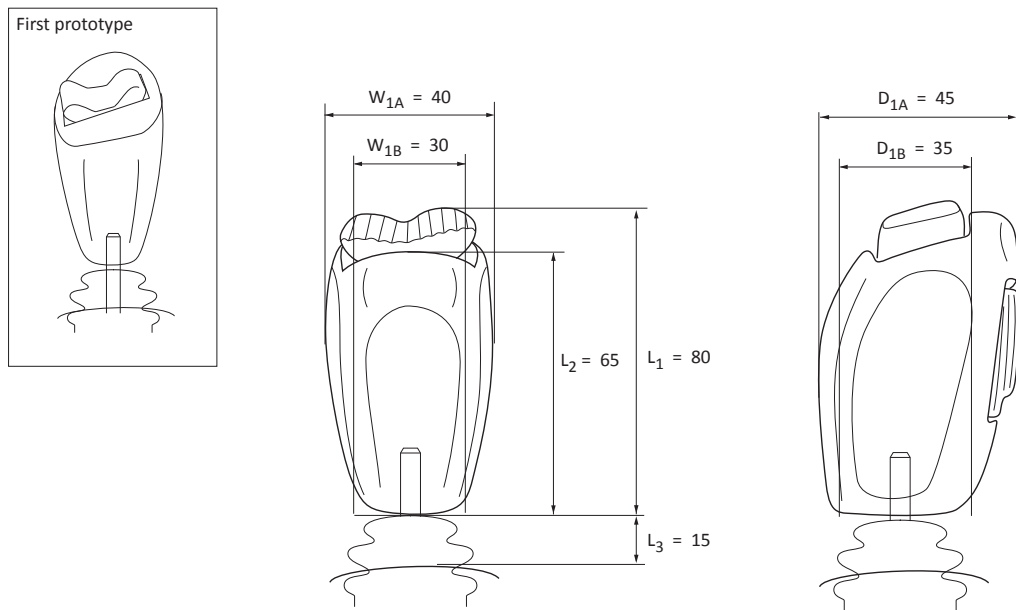
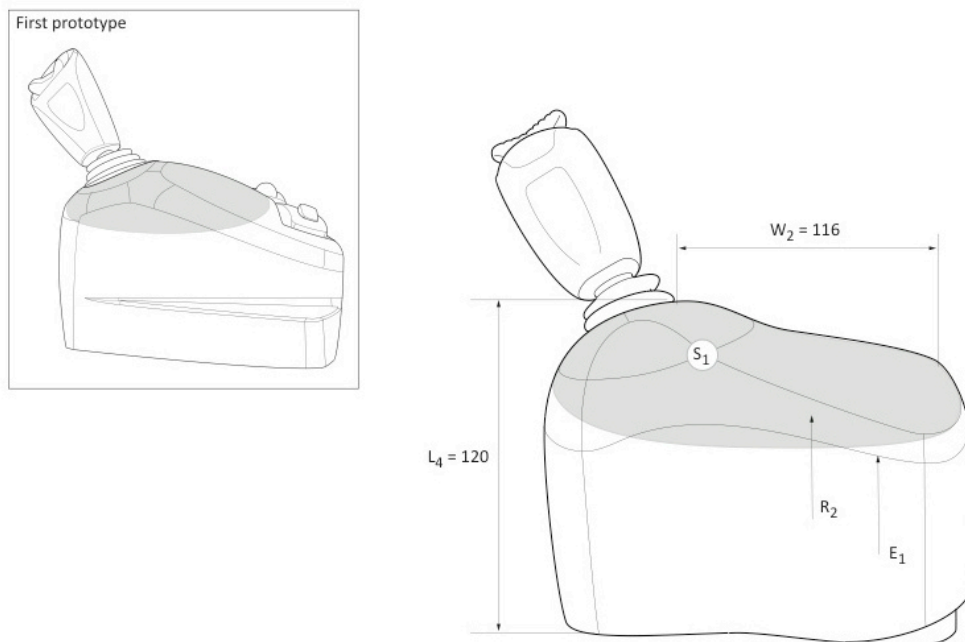

Figure 12.6 Handle

## Housing

In the concept evaluation it was revealed that there was a need for having an increased support for the palm when holding a grip further down on the handle (*need 5.3, table 12.1*) (*need 19.2, table 12.3*). The surface S1 (*figure 12.7*) was therefore made more protrude closest to the handle. The new surface does also give an increased support for the hypothenar when gripping a full handgrip (*need 5.2, table 12.1*) (*need 19.1, table 12.3*). The lower edge of the housing has been fitted to the lower plastic cover and the housing have been centered in front of the armrest, (*need 21.1, table 12.3*). The edge E1 have been shaped to follow the armrest (*need 21.2, table 12.3*). The height of the housing have been changed to  $L_4 = 120$  mm (previous 110mm) to give the operators a better support when there is large vibrations in the machine (*need 20.2, table 12.3*).

The integration of the control panel made it possible to make the housing wider,  $W_2 = 116$  mm (previous 96 mm) which increase the possibility to vary the grips on the hand support when no handle action in needed (*need 20.1, table 12.1*).



*Figure 12.7 Housing back view*

## Control panel

One of the reasons the buttons was placed too far away was because the measurement between the buttons and the housing was made between the front edges of the housing to the buttons in the belief that the operators would hold a grip further to the front. During the evaluation it was revealed that the operator actually held a grip further back on the housing creating a longer distance to the buttons than being anticipated, the measurement was therefore changed to the centerline of the handle instead. The buttons was placed in a straight line to make the button placement less cluttered and to facilitate for the operator to know where each button is placed. The integration of the housing and control panel (*figure 12.8*) made it also possible to place the buttons closer to the handle, which gave the distance between the handle and the *kick-down* and *engine break* to  $D_3 = 55$  (previous 60 mm) which would fit the index finger length of the 5<sup>th</sup> percentile of the world population.

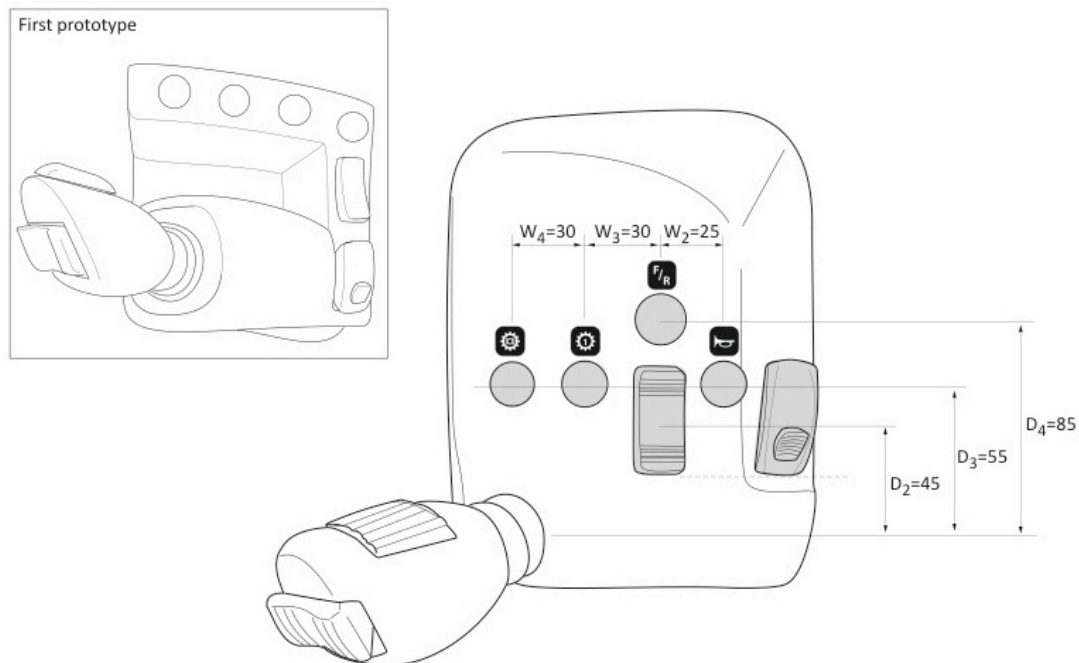

*Figure 12.8 Control panel*

## 12.4 Concept validation with reference group

Overall the participants approved the developed shape; there were however some individual differences in how they wanted to change the detailed shape of the palm rest. One participant preferred the previous prototype where he could firmly grip around the housing. One participant wanted a more cylindrical shape of the palm rest closest to the handle – he wanted to have a cylinder to grab and a bit steeper angle on the housing surfaces close to the handle. One participant felt he was slipping too much with his hand and would like to have a stop on the housing. One participant wanted a smoother shape on the transition surface where the thumb is resting against when controlling the joystick.

Most participants would like the handle to be a little bit thinner. One participant would like to have a more grip friendly material on the 3<sup>rd</sup> and 4<sup>th</sup> switch and a regular tine shaped switch for the 4<sup>th</sup> function instead. The participants liked the placement of the buttons but all agreed to switch place between kick-down and engine break.

The participants also commented that non of them operated wheel loaders all day long and that the opinion of wheel operators would be needed to really determine the comfort of the housing after a full day's work. The 3<sup>rd</sup> and 4<sup>th</sup> function would also have to be evaluated in a machine.



*Figure 12.9 Validation of final concept with reference group*

## 12.5 Final remarks on the concept

Input from stakeholders, end-users, reference group and own interpretations has formed the outcome of the project. The level of ergonomic optimization that has been reached is mostly related to the shape of the palm rest and the angling of the handle, which are validated by the final concept and reference group. The palm rest can be used as a reference point when controlling the handle, it provides a possibility to vary the grip, makes it possible for the operator to relax their hand when not controlling the handle and also supports the hand when it gets bumpy in the machine – avoiding the possibility for unintentional lever activation.

### Reflections on the reference group's comments

The prototype surface finish is painted with varnish paint and a bit slippery and the material and finish is has to be further developed. The participants' individual opinion on the detailed shape must be considered in the context of this small group; if the shape is too extreme in any of these directions, there is a risk the form will be designed for just one individual, not the large population the design should aim for. Theoretically, the ergonomic needs have been fulfilled; however further evaluation is required especially if analyzing the long-term effects the concept may have on the machine operators. Especially does the shape of the palm rest and the position between the palm rest and the armrest need more thorough testing during longer testing.

The technical limitations for the 3<sup>rd</sup> and 4<sup>th</sup> function (need 17, table 7.1) have been a challenge when developing the size of handle. The reference group wanted the handle to be thinner which is not possible to fulfill to any large extent due to the sensor, cables and other details that must fit into the handle. Furthermore, the sensors for the 3<sup>rd</sup> and 4<sup>th</sup> function might require other technical solutions, for instance; to be magnetically encapsulated - something that has not been possible to implement in the prototype. Depending on how the technical challenges are solved it will effect the shape of the handle and the design of the switches for the 3<sup>rd</sup> and 4<sup>th</sup> function.

### Remaining features to validate

Other needs that have not yet been possible to validate is the simultaneous use of functions, especially the 3<sup>rd</sup> and 4<sup>th</sup> function together with lift and tilt (need 8.4, table 12.2), the resistance in the joystick and the sensors (need 7.3, table 12.2) and the resolution in the machine response and the handle and the switches' movement (need 7.4, table 12.2). This is also clearly mentioned by the reference group.

### Aesthetics of the prototype

The technical limitations of the housing needing to fit the existing metal bracket (need 25, table 7.2) and the lower plastic cover (need 26, table 7.2) was the main reason to the overall aesthetics of the housing. The form development have been outside of the project scope and therefore not been prioritized. If however the form development had been included in the project's scope, collaboration with designers at Volvo AB would have been needed to provide a solution that meets the long-term vision of the Volvo brand which would have heighten the feasibility of the concept. A deviation from the technical limitations would probably have been needed in order to achieve a higher freedom in the form development to deliver a more aesthetic design.



# 13 Discussion

*Different aspects of the project and the project's outcome are discussed in this chapter. The topics closest to the final concept are found first, and other reflections later. The topics for discussion are written as ingresses for each text. This chapter also discusses methods used in the project and also choices made for methodology and procedure.*

## 13.1 Goal fulfillment of the final concept

*The stated goals for this project are discussed in this text. The concept should: be as original as possible and not a conscious replication of existing products; be designed for wheel loader environment; improve physical ergonomic conditions for the machine operator; improve the learning curve for novice operators; meet the market's demands.*

### **Is the concept original and ergonomically designed for wheel loaders?**

Analyses of who the user is, what the task is and how the user is affected by the task have resulted in identified issues and ergonomic needs that have to be fulfilled. The main identified ergonomic issue that exist with the current linear control levers, with the operators using unnatural hand postures and spreading their fingers to reach all levers, have been solved through integrating all four functions in one single lever. The mini-joystick concept minimizes the required lever movement and makes it possible for the 5<sup>th</sup> to 95<sup>th</sup> percentile to reach all four functions in one grip. The palm rest is especially designed for a wheel loader environment to give a support when it gets bumpy in the machine and avoiding unintentional lever movements. The palm rest also gives a possibility to vary the grip and provides a hand support enabling micro-breaks so that the muscles in the hand can rest – minimizing the overall strain on the muscles.

With these features in mind the mini-joystick concept have been ergonomically optimized, however as mentioned in *chapter 12.5* further evaluations are required to analyze the long-term effect the concept may have on the machine operator. The fact that the concept specifically has been designed for a wheel loader environment, using input from research, stakeholders, end-users and own analysis have resulted in a innovative and unique ergonomic concept that cannot be found elsewhere on the market.

### **Is it easy to use and does it improve the learning curve for novice operators?**

It will require an adjustment for machine operators being used to the linear control levers to get used to operate the machine with a mini-joystick instead, however did most of the participants from the reference group say that it was easier than they had expected to get used to the mini-joystick – and they only tried it for 20 minutes.

From a cognitive ergonomic point of view the natural mapping is better if using linear levers instead of a joystick. We do however believe that the simultaneous use of *lift* and *tilt* will be improved for novice operators since it will be easier for them finding a good balance between the functions using one single lever instead of two linear levers. As for now we cannot objectively state if the mini-joystick concept is easier to use than the linear levers – it will have to be further evaluated using a fully functional prototype with all functions integrated and when the resolution between the machine response and the handle movement have been optimized.

### **Does it meet market needs and use existing solutions?**

The use of a mini-joystick concept meets the market's needs. The concept have been developed using existing technical components and the dimensions are fitted to exiting parts in the machine – the metal bracket, the lower plastic cover and the armrest – making the concept more feasible and cost-effective.

## **13.2 Feasibility of concept**

*This project has focused on a design of a new single lever for wheel loaders. The initial approach has been to develop this in an ergonomic point of view. But, the delimitations have also enclosed the design, so a lot of considerations were taken on dimensions and choice of technical solutions, in order to make this a feasible product.*

The feasibility must be regarded as good. The ergonomically developed surfaces and dimensions, specified in *chapter 11*, are the outcome from the iterative phases, both by us project members and by the reference group. But, these design features are also fitted onto a housing that in turn is fitted to existing metal bracket, armrest and also fit an existing lower plastic cover. The armrest rig, the reference group, and us being able to use existing technical solutions gives pre-requisites needed to make the concept feasible. This has meant that the feasibility has been prioritized early in the development for fast execution of the project and a minimum of technical development is needed to make it into a real product.

### **Side effects of the approach**

But, the focus on feasibility can of course have other downsides. The form development might have been down prioritized. This project has never focused on the aesthetic form development; this has been out of the scope. But if we would have been able to work closely together with a designer, we would have used that opportunity and also integrate that as well. In that perspective, we can agree on that the prototypes developed do have a distinct, but not in all aspects an esthetically appealing form.

## **13.3 Work process and procedure**

*The project has been part of a pre-study that investigated possibilities of a single lever for wheel loaders. As this master's thesis project has been part of an existing work process, this project have had to adopt the timing and finishing of phases to be in sync with this pre-study. Ergonomic methods have been used to both analyze the existing situation and also been used to withdraw conclusions for the development. The design methodology is adopted from project members' previous knowledge, to find problems in the context of wheel loaders regarding levers, developing concepts for that context and evaluate these concepts.*

A large amount of literature has been used to found the basis for the analysis. This research has given a lot of data but it has also been hard work to summon and finalize this data into a part of the report. The research has been time consuming in a way that is not in line with proportion to the number of pages the data is given in the report; the data has to be easy to understand, the purpose and the use of the relevant data must be easy to follow. A lot of our own understanding from researching and the use of the data may not be perfectly reflected in this report, but all data described has been used in the some part of the project.

Most of methods described and used in the project have been specially adopted for this project and some gave more valuable input than others. It is easy to just perform a



method without reflections on the purpose and the outcome from it, but the methods described has all been used with the intention of delivering useful data - this is sometimes not obvious to the reader. For instance: the anthropometric analysis gave a lot of measurements used in concept development, but for the final concept only a few measurements could be stated as guidelines for specifications.

In other future projects, the methods might be used more integrated with each other, and not used isolated as they are described in the analysis chapter. Most useful for establishing goals for the design was the ergonomic analysis in Jack together with the anthropometric measures. The use of the mannequin revealed what postures that are most comfortable. Jack also revealed how much the users vary in size and how much ability for adjustments that is really needed. We can also guess that it is the most accurate and objective method as well, as there are more possibilities of creating a detailed model of the reality. But, the main purpose of it is not analyzing and scoring ergonomic postures of the hand. The observation study of the hand postures may have given the best output of the ergonomic situation of current product. Here, Jack and RULA are much too coarse and other methods are needed in order to give valid objective data and ratings.

The cognitive ergonomics have been harder to study; the methods used are easier to apply on interface with visual interaction, such as process models. The whole wheel loader was also defined within the system border for the analysis, and the interaction border was in practice the cabin, and this made the analyses a bit coarse. So, we could not use a lot of the data from the methods as the results mainly regarded the whole work place, the cabin. The ACTA method with interviews according to it, gave a massive amount of data. Still, a lot of data had to be discussed in order to withdraw conclusions related to the control levers. Most rewarding might be the description of operator's perception together with ACTA that conclude that the motoric skill together with tactile senses is used to interact with the levers. So, avoiding any delays and connecting the human in direct control with instance machine response must be the most important design heuristic. But we have not been able to test these characteristics of the joystick, this is outside the scope and we recommend that a thorough testing be made of the controlling software after this project.

During the concept developments and the iterative procedure the practical work with mock-ups and prototypes with the armrest rig must be regarded the most rewarding in this ergonomic project. CAD-models in computer software would not have given such deep understanding of concepts as the physical prototypes. Only a physical mock-up can be held and try-outs can be instantly performed in the workshop (*also chapter 13.4*)

An important part for the outcome of this project has been the machine evaluation by the reference group. To use an existing product as reference and still see a better product in the concept is very fulfilling. The prototype was resistant enough for the test and we got a lot of input for refining the concept further. If we had the time and resources for it, another test of the final concept, perhaps as a 3D-printed model, with end-user on the field would really put the concept to the test. Hopefully this will happen, and then a potentially very successful product might be realized.

## 13.4 Specific topics of interest

### **The use of physical prototypes instead of using virtual tools such as CAD**

*CAD tools are often used for modeling concepts. 3D shapes are easy to flip and rotate in the virtual environment to see and understand the form. From such software it is possible to rapid prototyping in a polymer material. Analytical prototypes in form of sketches are also possible to produce in order to communicate ideas and concepts.*

For us, the only sensible way to try our ideas was to create something physical. A computer model of an artifact that is supposed to be gripped at the end, can probably only be perceived correctly if the hands are able to feel it. The eyes can decide if something looks good, but the hands “see” form faster and create a better perception of spatial form. Of course, rapid prototyping is available and often used in product development, but that would have been great cost, and also time consuming as this development was not just a redesign; it was a conceptual design with ergonomic character and an idea had to be validated instantly as soon as it generated. New forms, aesthetics or construction issues are better suited to be analyzed CAD, especially in early development when this saves money, but for ergonomic aspects, the physical prototypes are unmatched. At the presentations of concepts the sketches and renderings were first shown. The reference group were intended to evaluate them after this, and it was clear that it was not until later, when we let them to touch and hold the mock-ups, they really understood all aspects of each concept.

### **The use of the reference group for evaluation and validation**

*In product development projects the evaluation of concept can be done together with end-users at one end of the scale and only internally with the project members at the other end. In this case, the evaluators closest to the final product environment, was the reference group with people common to the situation. End-users have not been participating in the evaluations. Due to time completion, costs and secretes issues, the reference group was assigned.*

We, our selves would have like to use end-users in some phases of concept evaluations, but it never became reality. In to early phases the best input is given from people that is easy to contact and that the project can trust with information that sometimes can be intricate. The reference group was a valuable resource in the start, such as a source of qualitative input. The group had good knowledge of the project, what problems to overcome and also had knowledge of the current product. They could also express themselves with ease. Also, this resource was easy to contact for concept evaluations. If external end-users would have participated, the concept could have been regarded as a product too soon and undermining the concept, and maybe information might have been misused. A person not familiar with early concepts in product development can have difficulties to grasp the essence of the concept - it is not uncommon that such user devalues a concept if it does not look real enough. At the end we noticed the reference group input was restricted, the members could just provide valuable input to some extent. As several iterations of concept evaluations took place, and we presented recommendations and guidelines for motivating design features, the reference group started to use the same phrases, terms and motivations. Just like if our knowledge of the world became the same. It came to the point that the group members themselves expressed that end-users had to test the prototype on the field. For the next phases of development, outside this project, end-users are needed to give an opinions not nuanced by us, and also a more objective opinion of the concept.

## The choice of consider the 5<sup>th</sup> to 95<sup>th</sup> percentile of the world as user

*In ergonomic studies, a population must be chosen for the analysis. This delimitation is a must to validate the analysis and make the study feasible. As our efforts give input to a pre-study that is initiated by Volvo CE, the choice of considering the whole world population potential user was early defined as a requirement. Volvo CE has as a policy to consider the 5<sup>th</sup> to 95<sup>th</sup> percentile in this population.*

This choice has meant that we have considered this population as far as we have managed, but of course this is approach has been impossible to manage to the full. Looking at the end result of the concept, one can question of it really can facilitate all functions and fulfill all needs for this population. We have not been able to evaluate the concept with other than Swedes, so no other population can really be stated as to been tested. Some measurements can almost certainly also be regarded as impossible to really comply with the world population, as nothing is adjustable in size or distances. Therefore the choice of considering the world population can be regarded unreasonable, as the resources for the thesis and pre-study are not in line with requirement that follows this choice.

We have had to limit our self to study Swedish users when data collection has regarded personal contact for instance. When there has been research data available, we have used data for the world population. So, at least in theory we can state that we have considered the world population as far as we have could, and all our efforts have had this approach in mind. This has complicated our work as we have had to interpreted the data and imagine the corresponding effects of our design choices. Results from our evaluations with Swedes have also been interpreted and imagined if they conform to the needs.

## 13.5 We have learnt

*There is no project that is identical to another, and the management of a project always needs to overcome obstacles to reach the project goals. This project has been a part of another pre-study, and this means adaptations had to be made to be in sync with that. The product development has been focused on ergonomics and this aspect has also colored the procedure and design choices.*

As this project has been closely connected to companies that is used to working with product development, it has been interesting to be part of a team in different context and see the dynamics of a development project. We have gained some insight in the relationships between small business and larger.

The planning was because of that tricky as the academic work often can be time-consuming. If that work had prioritized, the deadlines for the project would not always be met. But, this kind of thesis work is to some part practical and hands-on. We must realize that theoretical work is not always in line with real product development, so we are happy to been part of a real project and have adopted the academic work to that.

The project also gave us opportunity to use ergonomic analysis methods in practice and enhance our competence within this area. We have also found ourselves actuating the need for better ergonomics, and have defended a lot of design choices for the behalf of the ergonomics.

If we were to do this project again, or do another similar project, we would probably contact designers our selves and integrate the ergonomic development closer to the form development. The theoretical research and analysis methods would probably be adjusted to this and be a bit more pragmatically executed. But, then we would not understand and know so much of the operators' situation and the ergonomics in this context.



# 14 Conclusion

*Discussions about the validation of the concept, remarks on the final concept and prototype, and fulfillment of goals are concluded in this chapter. What the concept is really defining and what it is not are described.*

The final concept's features are repeated as a final remark: The concept is about using a joystick, i.e. a single lever controlling two functions by forward-backwards movements and right-left movements. Integrated inside this joystick handle, two additional functions are fitted. The thumb maneuvers the third function. The fourth is maneuvered by the index and/or middle finger. The angling of this handle and the size of it are very good from the ergonomic point of view; the analysis and evaluations validates this. The form of the upper part of the housing provide the user with support when it gets bumpy, gives a reference point as the user cannot watch the levers, and also gives the user opportunity vary the grip. The placements of the rocker switches and buttons are determined from literature and evaluations.

Anything else besides these features, such as the overall form, the colors, dimensions etc. are not regarded defined by the final concept.

## **Quality management**

The project is executed relying on fulfilling needs from different stakeholders by specifications on the described concept. The validation is made by evaluating the prototype with a reference group that has a high level of understanding and knowledge about the context and implementation. This procedure is an aim for securing the quality of the project output and also fulfilling the stated project goals.

## **Fulfilment of goals**

The outcome is a design concept that is innovative as it is a unique design specially developed for wheel loaders. The usability and cognitive ergonomics are not fully validated and must be further studied, but the physical ergonomics are regarded improved for the end-user; wheel loader operators all over the world. Ergonomic issues, if any, of the concept as well as current products, are considered effects from the long-term use. It fulfills markets' needs of a single lever and is feasible for fast implementation in current Volvo CE's wheel loaders.

## **For further development**

Field tests using end-users are highly recommended for the usability aspects as well as for setting exact specifications of the form. A long-terms effect of the concept is only possible to evaluate if testing fully functional prototypes for a considerable period of time in real working situations. The aesthetics must be further developed to fit design strategies. Materials and exact constructional issues must take environmental issues into consideration, which has not been within the project's scope.



# References

## Literature

Adolfsson, Niklas, Öberg, Kurt & Torén, Anna (2002). Biomekanisk analys av belastning i höft och skuldra vid varierande sittställning i hjullastare [Elektronisk resurs] = Biomechanical analysis of hip and shoulder load at varying sitting postures in wheel loaders . Uppsala: JTI - Institutet för jordbruks- och miljöteknik. [Electronic] Available: <<http://www.jti.se/index.php?page=publikationsinfo&publicationid=204&returnto=96>> [2011-09-01]

Adolfsson, Niklas, Öberg, Kurt & Torén, Anna (2004). Förebyggande av belastningsskador vid arbete med armstödsburna reglage i mobila arbetsmaskiner = Armrest control levers in mobile working machines - prevention of musculoskeletal disorders . Uppsala: JTI - Institutet för jordbruks- och miljöteknik. [Electronic] Available:<<http://www.jti.se/index.php?page=publikationsinfo&publicationid=174&returnto=96>> [2011-09-01]

*AFS, Ergonomics for the prevention of musculoskeletal disorders - AFS 1998:1* . (1998). Solna: Swedish National Board of Occupational Safety and Health, Publishing Services

Andersson, Jonas (2010). *A conceptual model for analysis of automation usability problems in control room settings*. Licentiatavhandling (sammanfattning) Göteborg : Chalmers tekniska högskola, 2010

Attebrant, M., Winkel, J., Mathiassen, S. E. and Kjellberg, A. (1998) Shoulder-arm muscle load and performance during control operation in forestry machines : Effects of changing to a new arm rest, lever and boom control system. *Applied Ergonomics*, 28, 85-97.

Blanchonette, P (2010) *Jack Human Modelling Tool: A Review*. Victoria: Air Operations Division DSTO Defence Science and Technology Organisation. [Electronic] Available: <<http://www.dtic.mil/>> Search criteria: Jack AND review. [2012-02-29].

Cross, Nigel (2008). *Engineering design methods: strategies for product design* . 4. ed. Chichester: John Wiley

Flood, L. F. & Carson E. R. (1993) *Dealing with Complexity – Chapter 1: Systems: Origin and Evolution, Terms and Concepts*

Gellerstedt, S. (2000) Ergonomic guidelines for forest machines. Proceedings of the IEA 2000/HFES 200 Congres 5 -7 of June .Uppsala.

Gellerstedt, S. (2002). *Manövrering av hjullastare*. Uppsala: JTI – Institutet för jordbruks- och miljöteknik.

Gilbert, B. G., Hahn, H. A., & Gilmore, W. E. (1988) Thumbs up: Anthropometry of the First Digit. *Human factors* 30(6), 747-750.

Hägg, G. M., Ericson, M. & Odenrick, P. (2009) Physical load. I: M. Bohgard (ed.), *Work and thechnology on human terms* (129-190). Stockholm: Prevent.

Höst, Martin, Regnell, Björn & Runeson, Per (2006). *Att genomföra examensarbete* . Lund: Studentlitteratur

Jack (6.1) [CAD software] Siemens PLM Software

- Johannesson, H., Persson, J-G., and Pettersson, D. (2004) Teori och metodik. *Produktutveckling – Effektiva metoder för konstruktion och design*. Stockholm: Liber AB, p.126-128
- Klein, G. (1997). *Applied Cognitive Task Analysis Job Aid*. Fairborn: Klein Associates Inc.
- Leonard, R. J. (1995). *Human gross anatomy: an outline text [Electronic]*. New York: Oxford University Press. [2012-02-07]
- Nilsson, B. & Rose, L. (2003) *Förbättrad arbetsmiljö för anläggningsmaskinförare*. Stockholm: Prevent.
- Norman, D. A. (2002[1988]). *The design of everyday things*. First Basic paperback ed. New York: Basic Books
- Osvelder & Ulfengren (2009) Physical load. In: M. Bohgard (ed.), *Work and technology on human terms* (339-461). Stockholm: Prevent.
- Osvelder, A-L., Rose, L. & Karlsson, S. (2009). Methods. In Bohgard, Mats. (red.) *Work and technology on human terms* . Stockholm: Prevent, p. 171-173
- Osvelder, A-L., Rose, L. & Karlsson, S. (2009). Methods. In Bohgard, Mats. (red.) *Work and technology on human terms* . Stockholm: Prevent, p. 180-182
- Osvelder, A-L., Rose, L. & Karlsson, S. (2009). Methods. In Bohgard, Mats. (red.) *Work and technology on human terms* . Stockholm: Prevent, p. 520-523
- Peebles, L. & Norris, B. (1998). *Adultdata: the handbook of adult anthropometric and strength measurements : data for design safety* . [ London]: DTI
- Pheasant, Stephen & Haselgrave, Christine M. (2006) *Bodystace: enthropometry, ergonomics and design of work*. 3. Ed London: Tylor & Francis
- Sanders, M., S. & McCormick, E.J. (1993). *Human factors in engineering and design* . 7. ed. New York: McGraw-Hill
- Sasse, M., A. (1997). Extract from: *Eliciting and Describing User's Models of Computer Systems*. Brimingham: University of Birmingham
- SCOI, Southern Californian Orthopedic institute (2010). *Anatomy of the hand & wrist*. [Electronic] Available: <<http://www.scoi.com/handanat.html>> [2011-09-22]
- Ulrich, Kerl T. & Eppinger, Steven D. (2008). *Product design and development*. 4 ed. Boston, Mas.: McGraw-Hill/Irwin
- Volvo CE customer Support (2009) *Instruktionsbok L110F-L120F*. Eskilstuna: Volvo.
- Winkel et al (1998)
- Österlind, Kenneth (2007) Design I focus för produktutveckling: varför ser vi saker som de gör? 2. Omarb. Uppl. Malmö: Liber



## Figures

*Figure 1.1, figure 1.2, figure 1.3 and figure 2.1 (top left and top right)*

Volvo CE (2011 a) *Image Gallery*. [Electronic] Available: <<http://images.volvoce.com/>>  
Search criteria: Wheel loaders/G-series. [2011-09-30]

*Figure 2.1 (top middle)*

Volvo CE (2011 b) *Image Gallery*. [Electronic] Available: <<http://images.volvoce.com/>>  
Search criteria: Pallet forks. [2011-09-30]

*Figure 2.1 (lower left)*

Volvo CE (2011 c) *Image Gallery*. [Electronic] Available: <<http://images.volvoce.com/>>  
Search criteria: Material handling arm. [2011-09-30]

*Figure 2.1 (lower middle)*

Volvo CE (2011 d) *Image Gallery*. [Electronic] Available: <<http://images.volvoce.com/>>  
Search criteria: Sweeper. [2011-09-30]

*Figure 2.1 (lower right)*

Volvo CE (2011 e) *Image Gallery*. [Electronic] Available: <<http://images.volvoce.com/>>  
Search criteria: Snow. [2011-09-30]

*Figure 2.2, figure 2.5, figure 2.6 and figure 2.7*

Wheel loader attachments (2011). [Electronic] Available: <[www.google.se](http://www.google.se)> Search  
criteria: attachments volvo ce / PDF - *ATTACHMENTS Volvo Construction Equipment*.  
[2011-09-30]

*Figure 2.3*

Volvo CE customer Support (2011). *Operators Manual L150G-L220G*. Eskilstuna: Volvo.

*Figure 2.4*

Volvo CE (2011 e) *Image Gallery*. [Electronic] Available: <<http://images.volvoce.com/>>  
Search criteria: Wheel loaders/Illustrator drawing. [2011-09-30]

*Figure 2.8*

Direct industry (2012). [Electronic] Available: <[www.directindustry.com](http://www.directindustry.com)> Search  
criteria: Products/Automation:Regulation, Control, Communication/Joystick [2012-01-  
30]

*Figure 2.9 (Upper and second upper left)*

Ålö (2011) *LCS EasyDrive joystick* [Electronic] Available: <[www.alo.se](http://www.alo.se)> [2011-09-30]

*Figure 2.9 (Upper right)*

Ponsse (2011) *PONSSE Comfort* [Electronic] Available: <[www.ponsse.fi](http://www.ponsse.fi)> Search criteria:  
Product News/PONSSE comfort [2011-09-30]

*Figure 2.9 (Middle right)*

John Deere (2011) [Electronic] Available: <[www.who-sells-it.com](http://www.who-sells-it.com)> Search criteria: John  
Deere Loaders [2011-09-30]

*Figure 2.9 (Lower left)*

CAT (2011) [Electronic] Available: <[www.cat.com](http://www.cat.com)> [2011-09-30]

*Figure 2.9 (Lower right)*

Valtra (2011) *Ergonomic Valtra Armrest* [Electronic] Available: <[www.valtra.com](http://www.valtra.com)> Search criteria: Products/Tractor range/T series tractors/T direct tractors. [2011-09-30]

*Figure 3.1*

Bartleby (1918) *Gray's Anatomy 20<sup>th</sup> ed* [Electronic] Available: <[www.fpnotebook.com](http://www.fpnotebook.com)> Search criteria: Orthopedics/Anatomy Chapter/ Forearm Anatomy/III Anatomy: Muscles [2011-09-30]

*Figure 3.2*

Oswalder & Ulfengren (2009) Physical ergonomics. In: M. Bohgard (ed.), *Work and technology on human terms*. Stockholm: Prentice.

*Figure 3.3*

Assh (2009) *Motion Terminology Your Surgeon May Use* [Electronic] Available: <[www.assh.org](http://www.assh.org)> Search criteria: Information for public & patients/Hand Anatomy [2011-09-30]

# Appendix I – HTA

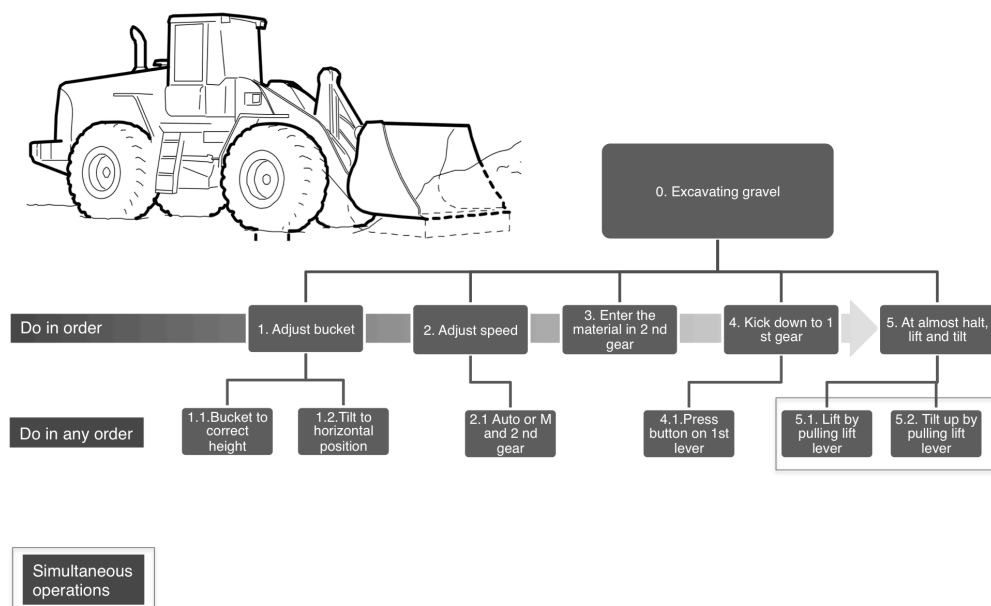

HTA of excavating gravel: this is the task requiring less effort. Simultaneous actions are present; sub – goal 5. This sub-goal is also a bit more complex in reality as the lever actions strongly depend on what gravel type that is to be loaded and many fine adjustments must be made (Volvo CE Customer Support, 2009 P. 139; Volvo CE, 2011).

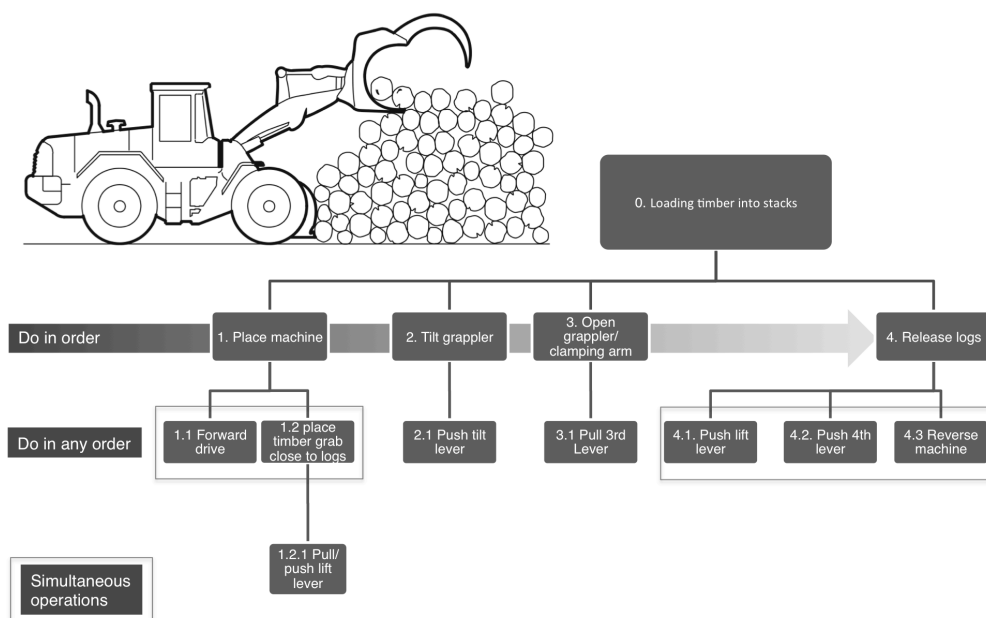

HTA of unloading logs into stack: unloading timber has similar characteristics as emptying a bucket of gravel; smooth, quick and simultaneous tilting and lifting is required. Both when loading timber into a stack or loading a truck, the tilt lever has to be adjusted at the same time as the machine must reverse away from the loading place. A lot of timber grabbers also have a second grapple that is operated by the fourth lever, demanding the hand to spread over all four levers (Volvo CE Customer Support, 2009 P. 143; Volvo CE, 2011).

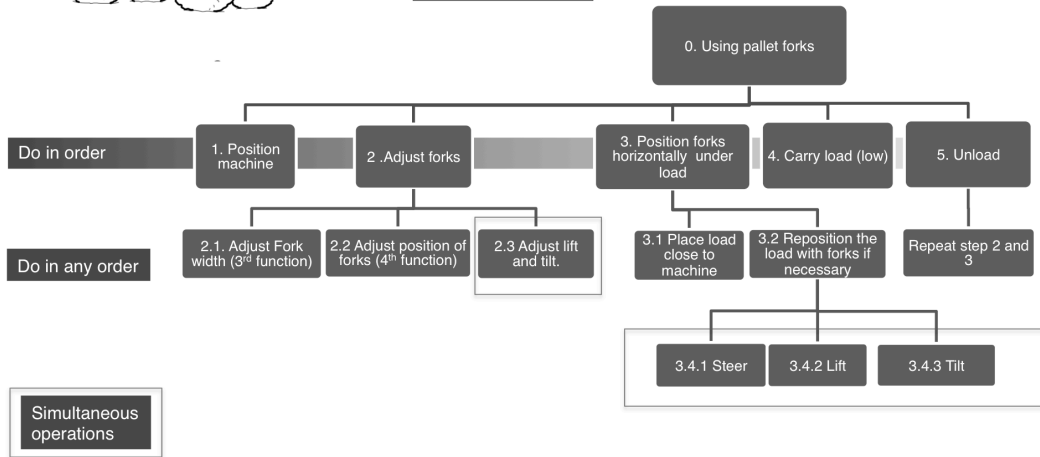
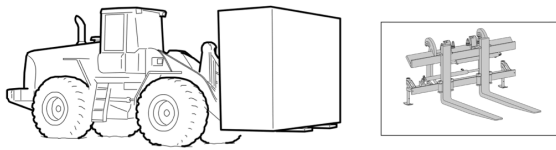

HTA of pallet fork work: using pallet forks is a little bit more complicated than loading and unloading gravel. But the basics are the same - smooth, quick and simultaneous tilting and lifting is required (sub-goal 2.3, 3.4.2 and 3.4.3). The difference is, depending on what object to lift, that the work requires more precision. Besides lift and tilt pallet work also requires a third and sometimes even a fourth function to adjust the width and sideways position of the forks. (2.1 and 2.2 are optional but common functionality (Volvo CE Customer Support, 2009 P. 143; Volvo CE, 2011)).

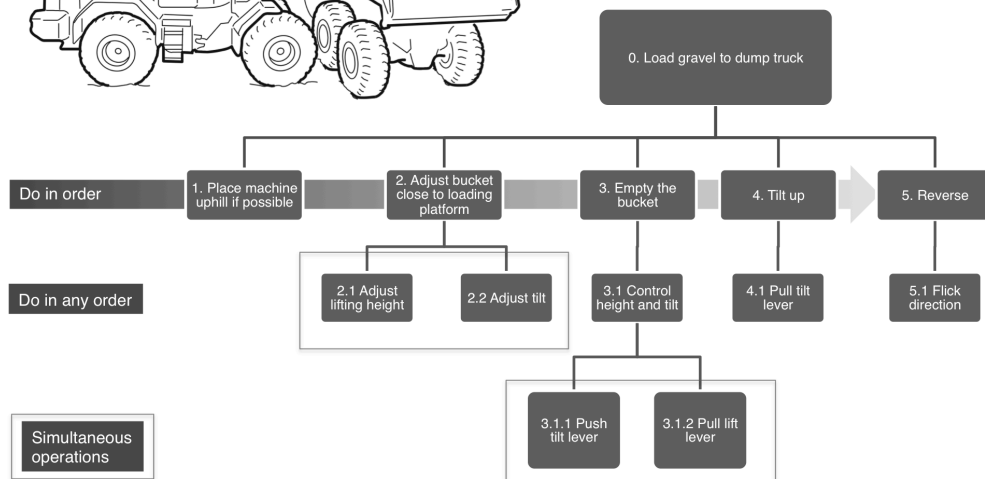
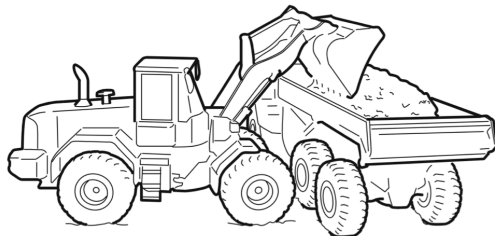

HTA of loading a dump truck with gravel: the task is characterized by the simultaneous use of lift and tilt in order to place the bucket and gently unload the material without spillage (sub – goal 2). Both of these actions are must be made with great precision, quickly and smoothly as small hasty movements may set the machine into a swing. The user must pull or push one lever to one max position and the other with precision. This puts a lot of forces in the hand due to the gripping and muscle activation. (Volvo CE Customer Support, 2009 P. 141; Volvo CE, 2011).

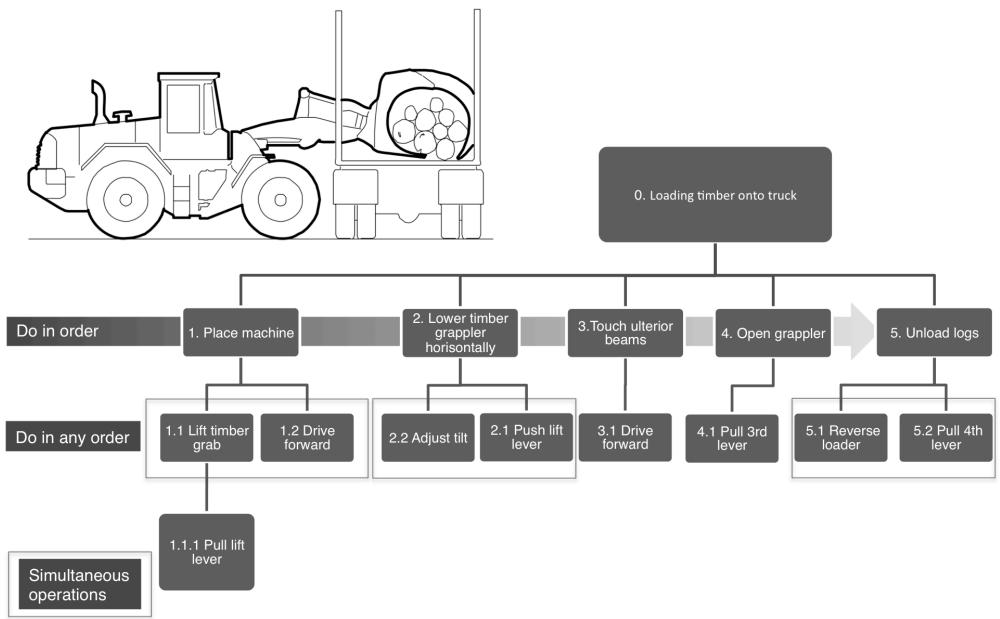

HTA of loading logs onto a truck: big challenges of simultaneous use of levers (sub – goal 1.1, 1.2 2.1, 2.2, 5.1, 5.2). In this task the user must be careful not to damage the truck bedside or any other part.



# Appendix II - Questionnaire

## Questionnaire; comfort and discomfort

Working years:

Machine you operate:

Do you have experience of other (Volvo) wheel loaders?

Height:

Age:

Weight:

**1. Do you feel your muscles aching that can be connected to your work?**

1. Not at all    2                    3                    4                    5. Very much  
                                                                               

**2. Does your arms feel heavy, in connection to the work?**

1. Not at all    2                    3                    4                    5. Very much  
                                                                               

**3. Do you experience stiffness in your body?**

1. Not at all    2                    3                    4                    5. Very much  
                                                                               

**4. Do you feel restless?**

1. Not at all    2                    3                    4                    5. Very much  
                                                                               

**5. How comfortable would you say your work is in the cabin?**

1. Not at all    2                    3                    4                    5. Very much

## Questionnaire; comfort and discomfort

Working years:

Machine you operate:

Do you have experience of other (Volvo) wheel loaders?

Height:

Age:

Weight:

### 1. Do you feel your muscles aching that can be connected to your work?

1. Not at all    2                    3                    4                    5. Very much  
                                                                               

### 2. Does your arms feel heavy, in connection to the work?

1. Not at all    2                    3                    4                    5. Very much  
                                                                               

### 3. Do you experience stiffness in your body?

1. Not at all    2                    3                    4                    5. Very much  
                                                                               

### 4. Do you feel restless?

1. Not at all    2                    3                    4                    5. Very much  
                                                                               

### 5. How comfortable would you say your work is in the cabin?

1. Not at all    2                    3                    4                    5. Very much



# Appendix III – Knowledge audit

Knowledge audit – Load gravel  
Step from Task Diagram: Unload bucket of gravel into truck.

Example	Cues & strategies	Why difficult?
Present and Future Knew about frozen parts in the gravel heap. – the whole heap may crumble.	Visual cues if the gravel is frozen up into pieces and the outside temperature. Strategy: Knowing about the behaviour of the materials due to temperature and weather.	Have no experience of frozen gravel.
The big picture Do it in time!	Watch the gravel slip and fall out from bucket. Slowly sneak the lever to empty the bucket.	Often pushes to hard, and the bucket hit the truck. Risk of damaging the truck. Novices do not compensate the weight of the material that makes the bucket tilt fast.
Noticing -	Visual inspection of bucket and cleaning from frozen materials that have been stuck. Strategy: step out of the machine to inspect... No short cuts.	There is no way of telling from within the machine if there are material left in bucket. Discovered by the truck when weighing the whole truck.
Job smarts Up marked areas for the loading on truck bed.	Some trucks have arrows to mark where the load should be. Unload rests in bucket by shaking. Strategy: Look for the arrows and aim. Communicate with truck driver.	They do not understand the truckers must keep the weight under 16 tons and the load distribution over the axis.
Opportunities improvising- .		
Self monitoring	Improve the manoeuvring skills to have good control over the bucket.	Takes time to learn the machine.

Knowledge audit – safety equipment  
Step from Task Diagram: Fetch the trench box with pallet forks

Example	Cues & strategies	Why difficult?
Present and Future Yes, but no isolated example. The trench box is placed on other equipment in wet conditions, leaning down towards ditch.	Cues: The location and bad positioning means that someone else have left the box there. Strategies: Fetch the box with pallet forks and drag to flat ground. Box must be levelled up by smooth manoeuvring.	Machine itself is leaning. Hard to manoeuvre the big machine and foresee the movement of the fork tips. Novels doesn't reflect on the weather. The
The big picture Do what headman ordered, but the box will be used as safety equipment somewhere. Don't destroy the truck nor the box...	Cues: The box is in two pieces, not more, but user don't know where the box is sent to. Use a flat ground and always have good order. Strategies: Keep the pieces as they are as they are probably used in near future. otherwise they would have been dismantled in more pieces. minimise risk for damage.	Not expressed by the foreman who is suppose to use it where it is heading. Hard for novels to understand where the structure is weak or strong. Not understanding the good effects of good order.
Noticing Yes, hitting emergency stop button because of a smoke that he spotted. Truck is not on site as the foreman sad.	Cues: Visually realised that truck is not there. Strategies: Get more information from the first source of information, the headman	Missing cues stated in elements above and maybe disbelieve if the location was right.
Job smarts Use the machine as much as possible instead of physical body work...	Cues: Recognise and find a flat and better ground. Strategies: Trust the manoeuvrability of the machine and use the fork tips to fetch the box and move the box towards flat ground. Always use a place that is flat.	Is not comfortable with expressing their requests for better conditions, such as fixed, flat places for storing equipments.
Opportunities improvising That occurs all day long, nothing is static.	Cues: Skewed placement. Strategies: use fork tips to move it closer and toward flat ground.	Hard to know if the structure is strong enough. Estimate the weight is sometimes hard, it is felt trough the levers and machine swing - haptic.
Self monitoring Sometimes, but often the job falls in routine. Small accidents have happened. For instance with a car. (Material damages only).	Cues: Feeling in levers and machine. Stress could be a cue. Strategies: Constant monitoring, but no specific instrument of following up performance. If damage is done some reflection is made of course.	Stress more easily, forgets importance of also do the job safe. Trying to please the headman.

**Knowledge audit– safety equipment**  
 Step from Task Diagram: Load the box onto the truck bed

<b>Example</b>	<b>Cues &amp; strategies</b>	<b>Why difficult?</b>
Present and Future Yes, but no isolated example.	Cues: Box is slippery and slips easily. Cold weather outside. Strategies: Avoid box to slide off by smooth manoeuvring.	Novels doesn't reflect on the weather. The balance is somehow felt and this feeling has to be learnt.
The big picture Keep both the headman and orderer happy. Be quick and plan the tasks.	Cues: A truck waiting, he cost money! Several task are ordered. Strategies: Prioritise this order and combine the other task as the need other equipments to be performed	Not always expressed by the foreman that chartered entrepreneurs is costly if they wait.
Noticing Yes, hitting emergency stop button because of a smoke that he spotted.	Cues: Visually realised that truck driver don't see and perceive the slippery box. Strategies: Warns truck driver by phone that this might rock the truck if the box slides off and clash into the truck bed.	Don't think through the next possible events. (Missing cues stated in elements above)
Job smarts Use the machine as much as possible instead of physical body work...	Cues: If the structure of the truck bed sides looks rigid enough to withstand the load. Strategies: Trust the manoeuvrability of the machine and gently let the box slide of towards the truck bed.	Don't trust the machine and do not estimates the weight of the box properly. Do not know that it is possible to penetrated the structure with the forks.
Opportunities improvising That occurs all day long, nothing is static.	Cues: Estimate distance to opposite side of the truck bed side. See the outer corners of the box for aiming. Strategies: Let the box slide slowly with control until it touches the opposite bed side.	Estimate distances and foresee the sliding demands routine or practice.

# Appendix IV – Simulation interview

## Simulation interview

Weigh bucket load

Event	Action	Situation assessment	Critical cues	Potential errors
Place bucket in correct height	Lift up bucket by pulling the lever.	Have correct height and not be in the heap.	Visually.	The scale may be less correct if in wrong position or in gravel heap.
Decide if the load is correct, too high or too low.	Push correct set of buttons. Read the figures.	There is material enough for the client or; There is too much or too low weight – emptying and refilling is required.	The cumulative load should be 16 tons, and definitely not exceed 17 tons.	Truck driver may be fined for overload. The truck is not filled and cost more money per ton of transported gravel.

## Simulation interview

Weigh bucket load

Event	Action	Situation assessment	Critical cues	Potential errors
Place bucket in correct height	Lift up bucket by pulling the lever.	Have correct height and not be in the heap.	Visually.	The scale may be less correct if in wrong position or in gravel heap.
Decide if the load is correct, too high or too low.	Push correct set of buttons. Read the figures.	There is material enough for the client or; There is too much or too low weight – emptying and refilling is required.	The cumulative load should be 16 tons, and definitely not exceed 17 tons.	Truck driver may be fined for overload. The truck is not filled and cost more money per ton of transported gravel.



# Appendix V – Protocol

Protokoll videoanalys

Objekt:

## 1 Genomsnittlig cykeltid

Cykelstart: Objektet tömmer första skopan. Cykelstop: tömmer sista skopan.

	bananspak	Minispak
Antal uppmätta cykler		
Genomsnittlig tid		

Tidigare erfarenhet av joystick:

## Ergonomisk analys enligt RULA

Analysering av de mittersta 15 min i 10 sekunders intervaller => 90 analyser.

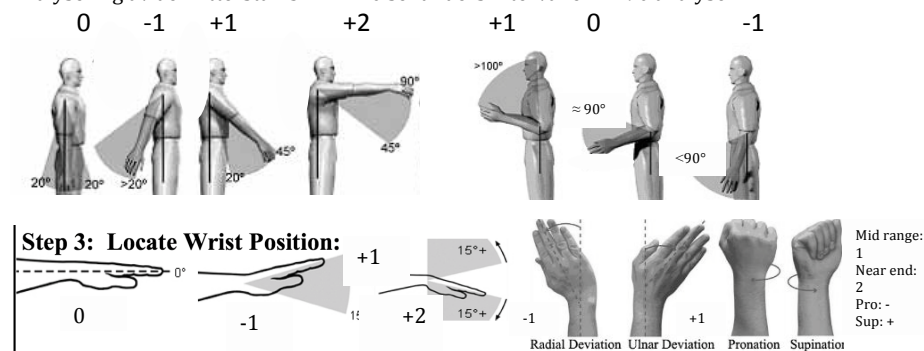

Banan

Axel:

Armbåge:

Handledens flexion/extension:

H. deviation:

H. pronation/supination:

Summering:

Differens mot intervjuer

Uppgivet handgrepp:

Avvikelser:

Mini

Axel:

Armbåge:

Handledens flexion/extension:

H. deviation:

H. pronation/supination:

Summering:

Differens mot intervjuer

Uppgivet handgrepp:

Avvikelser:

Anmärkningsvärt:



# Appendix VI - Questions

## 14.1.1 Overall

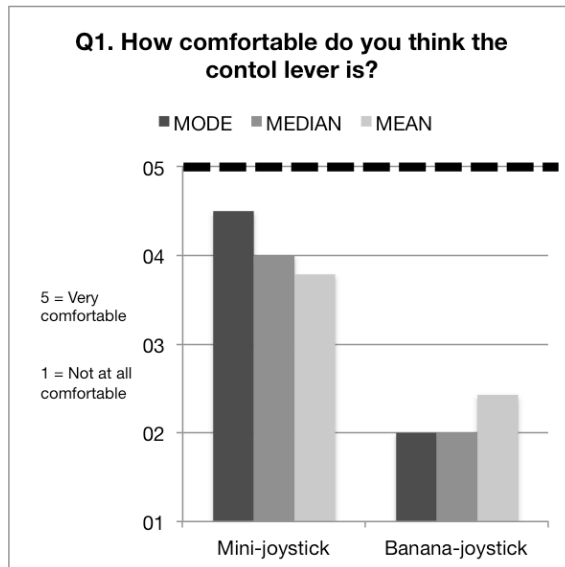

**Chart.Q1. Mini-joystick: STDEV 1,0.  
Banana-joystick: STDEV 0,5.**

The result of the first question in the questionnaire can be seen in chart Q1. The participants were also asked what they thought was comfortable and what could be improved. Most participants commented that the mini-joystick housing gave a good support for the hand. They used the housing as a reference support when using the lever and they could rest their hand against the housing to prevent unwanted lever movements during bumping conditions. One of the participant said that the possibility of using different grips made the housing more comfortable.

One participant experienced a small discomfort on the inside of the hand that was placed towards the housing – probably due to a high pressure. The

participant mentioned that he could have adjusted the armrest further away to reduce that pressure. This discomfort could also be reduced through adding a softer material to the surface that the hand is resting against on the housing, e.g. PUR – the same material that is used on the armrest.

All participants liked that the joystick was angled. Two participants thought that it was a little bit too much angled (5-10°) inwards. They said that the lever might touch the operator's leg at full stroke length inwards.

Two participants wanted to have more support from the housing. The first wanted the housing to be more cupped close to the lever – like the support for the CDC. The other wanted the housing to be more hollowed. Both suggestion demands the housing to provide an increased vertical support. One participant suggested that the housing could be integrated in an extension of the armrest while some participants wanted to add more adjustability possibilities between the positioning of the housing and the armrest. One participant wanted to be able to adjust the distance between the housing and armrest and one participant wanted to be able to rotate the housing sideways.

Two questions were asked regarding the grip; what kind of grip the participants preferred and how they think the grip could be varied. Most participants said that they would need more time to find the preferable grip. All participants used different grips when operating, however three main grips were identified.

### 14.1.2 Size and shape

The participants were asked what it was about the shape that they liked / disliked and how aesthetic they thought the handle, housing and control panel was. Overall the participants liked the shape of the handle and thought it felt good in the hand. One participant said that the transitions between surfaces, on top of the handle, had too small radii and too more sharp edges. One participant would have liked a rounder and more spherical shape while the other participants liked the egg shape. Most participants appreciated the chamfered surface for the thumb.

The aesthetics was not important for the participants. One participant said that the angle of the joystick made it look more ergonomic and designed. One participant said that it looked more futuristic than the banana-joystick. One participant said that the housing looked a bit weird. One participant said that he liked the conical shape of the lever while another participant would have liked a less conical shape to make it look less dramatic.

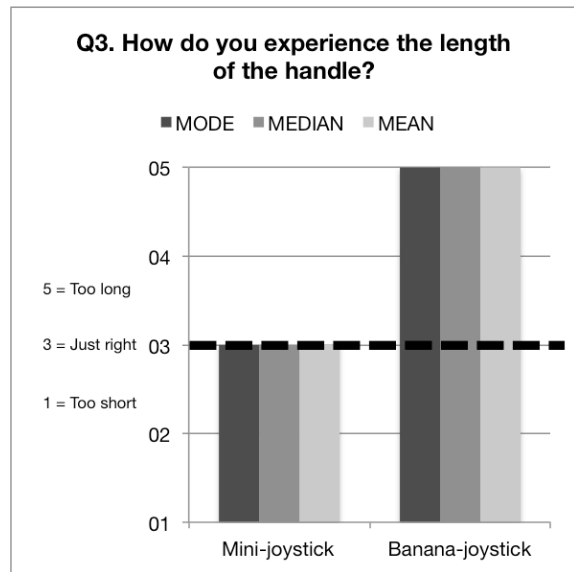
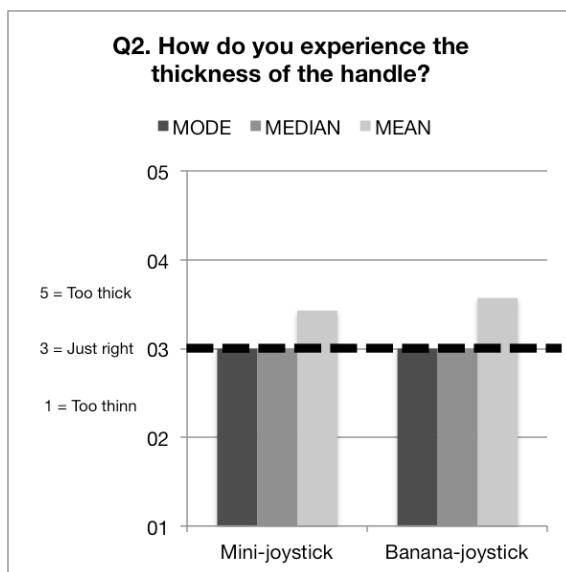

**Chart.Q2. Mini-joystick: STDEV 0,5.  
Banana-joystick: STDEV 0,7.**

**Chart.Q3. Mini-joystick: STDEV 0,0.  
Banana-joystick: STDEV 0,0.**

In the second and third question in the questionnaire the participants were asked how they experienced the thickness and length of the handle, see chart Q2 and Q3. Some participants said that the handle was a little bit too thick when only using the thumb and index finger. They would like it to be a little bit thinner (5-10mm) at the bottom of the handle. All participants liked the length of the handle.

The participants were asked how they perceived the distance between the handle and control panel. Almost all participants thought that the control panel was placed too far away. They found it hard to reach the buttons and would like the button to be placed so that they do not have to change the grip. The participants were also asked about how they perceived the distance between the buttons. The overall answer was that they should not be placed further away.



### 14.1.3 Placement

In the fourth and fifth question in the questionnaire the participants were asked what they thought about the placement of the 3<sup>rd</sup> and 4<sup>th</sup> function, see the result in chart Q4 and Q5. Most participants liked the placement of the 3<sup>rd</sup> function. One participant suggested that the 3<sup>rd</sup> function could be placed on the base instead. One participant would like to have a scroll wheel instead of the switch. One participant would have liked a better support for the thumb in front of the switch or a larger surface at the left side of the switch to rest the finger on while not using the switch.

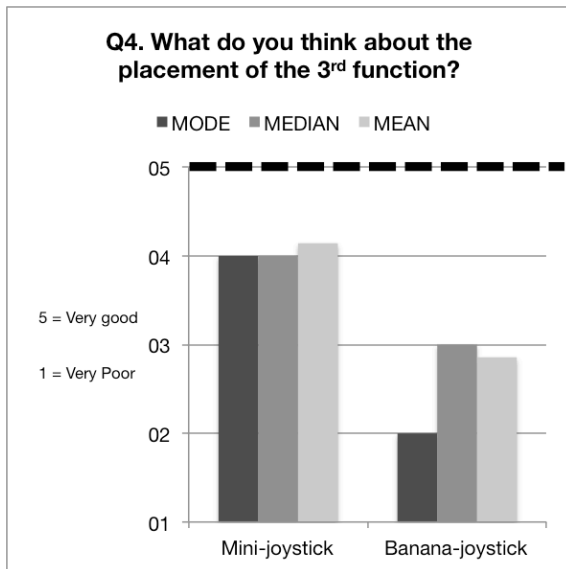

**Chart.Q4. Mini-joystick: STDEV 0,6.  
Banana-joystick: STDEV 0,8.**

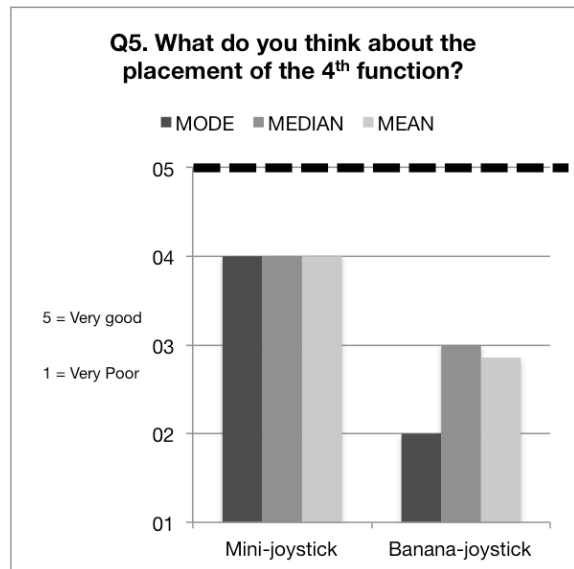

**Chart.Q5. Mini-joystick: STDEV 0,5.  
Banana-joystick: STDEV 0,8.**

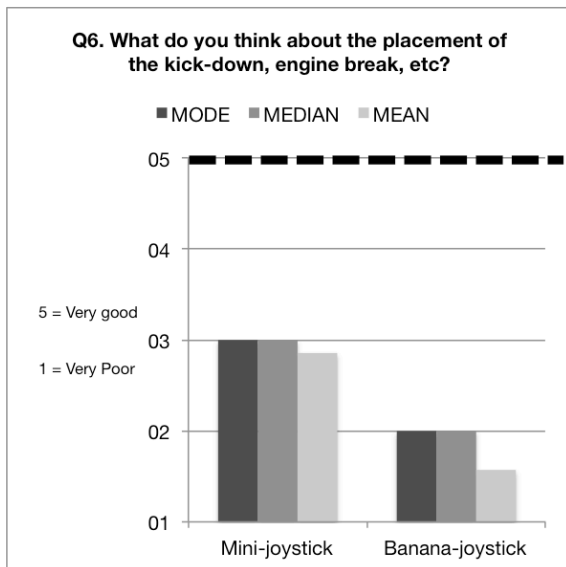

**Chart.Q6. Mini-joystick: STDEV 0,6.  
Banana-joystick: STDEV 0,5.**

Most participants liked the placement of the 4<sup>th</sup> function. Some wanted it to be placed a little bit further down on the handle. One participant wanted to move it 5 mm clockwise from the top view. Some participant was a bit worried that the 4<sup>th</sup> function might be in the way or might be accessed by mistake. Two participants suggested the use of a scroll wheel instead to reduce that risk. One participant suggested that the 4<sup>th</sup> function should be placed on the housing and one suggested that the 4<sup>th</sup> function could be placed on top on the handle instead. It should be noticed that neither the 3<sup>rd</sup> and 4<sup>th</sup> function was functional or used during the evaluation – the placement has to be further evaluated using different attachment.

As mentioned earlier the control panel was placed too far away from the handle. The result from the sixth question from the questionnaire can be seen in chart Q6. When asking the participants where they would like to place the buttons most wanted to place the kick-down button on the handle (where the 4<sup>th</sup> function is placed) or on the housing. Two participants used the automatic kick down function and did not see it as necessary to be able to access the kick-down button – instead they wanted the engine break button to be placed on the housing. Those who primarily did not use the engine break button also wanted it to be placed on the housing. The horn button was not highly prioritized. Most participants said that it is important to be able to reach it, however the placement do not have to change.

Most participants said that the direction selector was placed too far away. They would like it to be placed on the housing closer to the hand instead. One participant wanted the placement of the director selector to be similar to the placement on the CDC. Two of the participants would like to have the direction selector placed on the lever in order to not have to change the grip. Both of these participants used the steering wheel instead of the CDC when operating the machine.

The joystick lock rocker and the activation button for the direction selector had the lowest priority. Most participants said that these could be placed anywhere. One participant said that these functions could be excluded from the housing and control panel completely and placed for example on the A-pillar.

The participants were asked if there were any other functions / buttons that they would like to add to the control panel. Two participants suggested that a windshield wiper button could be added.

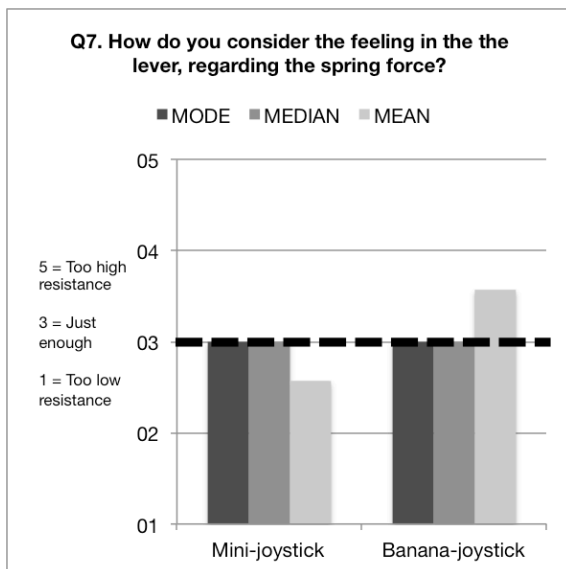

**Chart.Q7. Mini-joystick: STDEV 0,7.  
Banana-joystick: STDEV 0,7.**

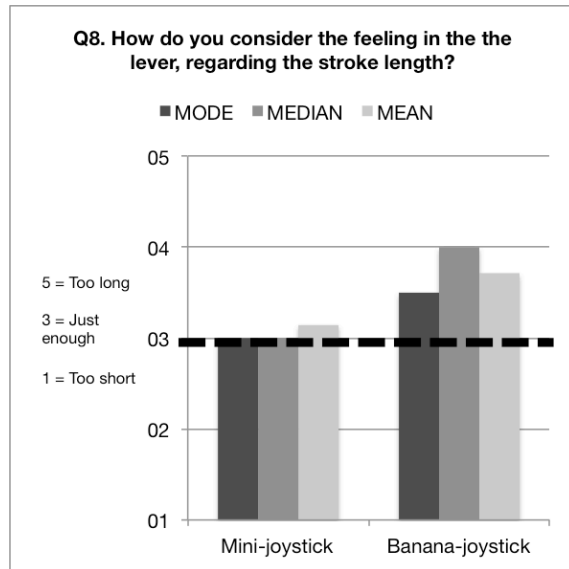

**Chart.Q8. Mini-joystick: STDEV 0,3.  
Banana-joystick: STDEV 0,7.**

#### 14.1.4 Function

In the questionnaire the participants answered how they considered the feeling of the joystick regarding the spring force and the stroke length; see result in chart Q7 and Q8. Two participants said that the spring force was too low. One of them said that he had to stretch his hand in order to control the lever. Most participants were however satisfied with the stroke length. One participant said that the stroke length was a bit too long.

The participants were asked how easy / difficult it was to separate the *lift* and *tilt* function. Some participants said that it was a bit hard since they were not used to operate the machine with a joystick, however most of them said that it was easier than expected. One participant wanted to have features in order to separate the functions better, something to enhance the feel of using one or both hydraulic functions. Some participants mentioned that it was a bit hard to fine tune the *lift* and *tilt* function, especially the *lift* function. The participants thought that this could be either because of the spring force or because of the joystick characteristics in the software.

The participants were asked what they thought could be improved in the correspondence between the joystick and the machine's movement. Some participants said that they experienced a delay in the machine's movement. They wanted a quicker response. Some participants said that too much happened close to the neutral position of the joystick. The response of the machine movement should rather be slower close to the neutral point followed by an accelerated curve further out on the stroke length.

The prototype did not contain any hold functions. In order to gather input for further development the participants were asked how they would like the hold function to be designed. Overall the participants found it hard to imagine how the hold functions could be designed. The suggestions were either to have a detent mode where the joystick-position would be locked; to have a pre-feeling mode where the hold function is activated or to have separate buttons to activate each hold-function.

### 14.1.5 Armrest

Even if the armrest is outside of the project scope it was a good opportunity to gather feedback since the armrest affects the overall comfort of the joystick. The participants were asked how they experienced the possibility to set the armrest so that they could sit comfortable. Only two participants were quite satisfied with the adjustability and comfort of the armrest, of which one of them said that he operates the machine so rarely that he does not feel any need of doing any settings.

The participants that were less satisfied wanted to be able to move the armrest further back. Some participants mentioned that they would like to adjust the vertical angle of the armrest and one participant wanted to get the armrest closer to the body horizontally – either by an angle or to move the whole armrest even closer.

Some participants mentioned that they would like to adjust the height between the control lever and the armrest and the height of the whole armrest – two adjustment possibilities that are possible to perform with the armrest, that the participants either did not know that it could be adjusted or did not know how to adjust it.

# Appendix VII – Result questionnaire

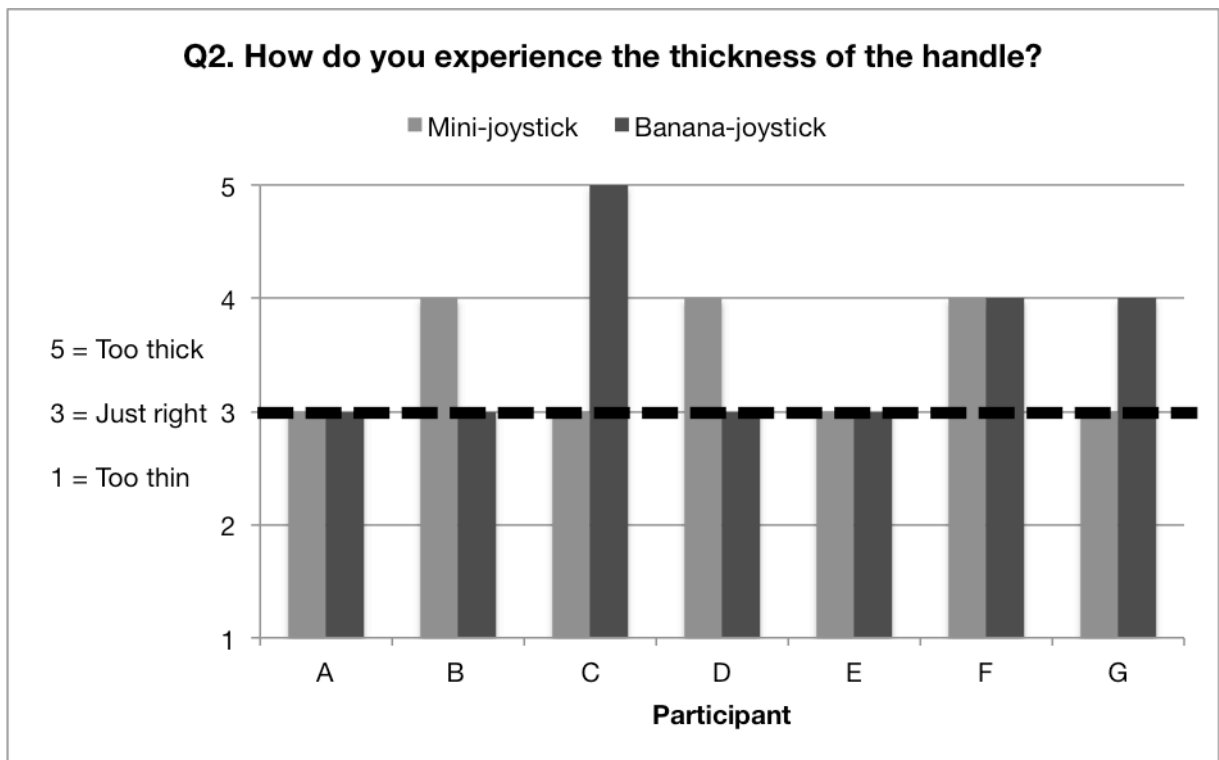
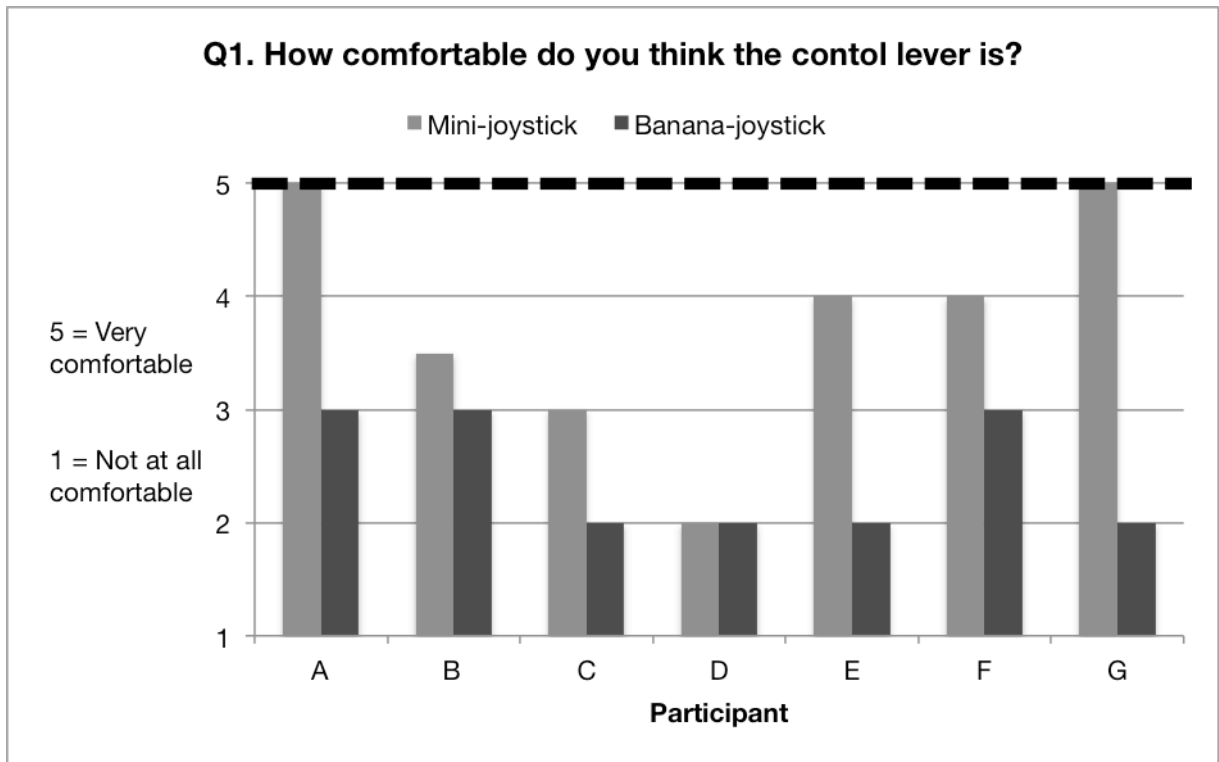

### Q3. How do you experience the length of the handle?

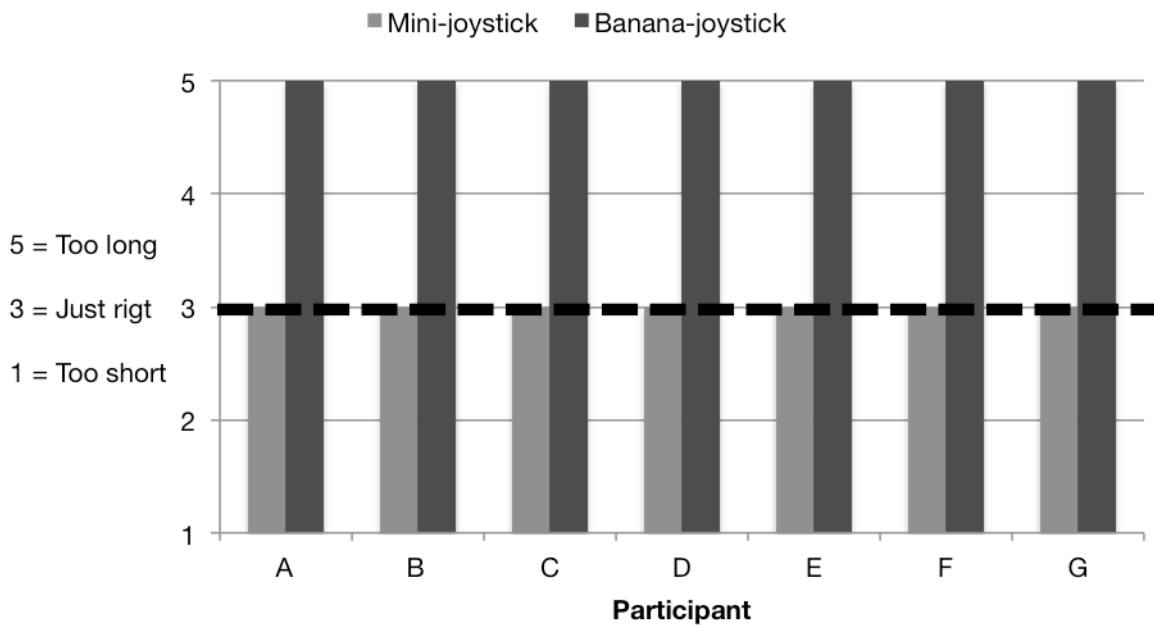

### Q4. What do you think about the placement of the 3<sup>rd</sup> function?

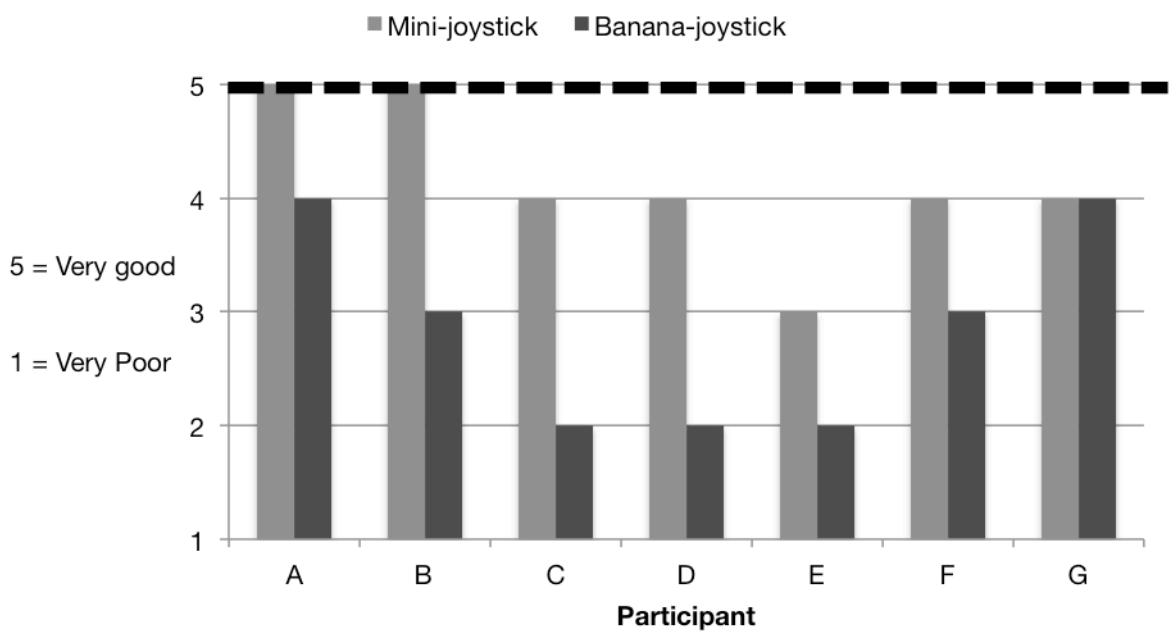

**Q5. What do you think about the placement of the 4<sup>th</sup> function?**

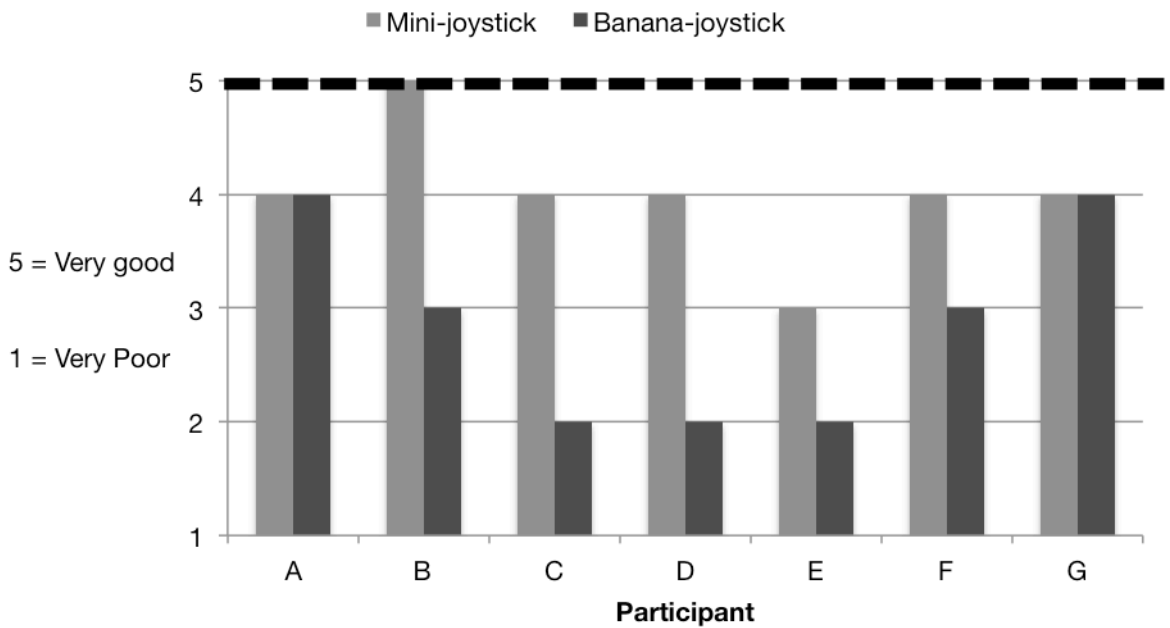

**Q6. What do you think about the placement of the kick-down, engine break, etc?**

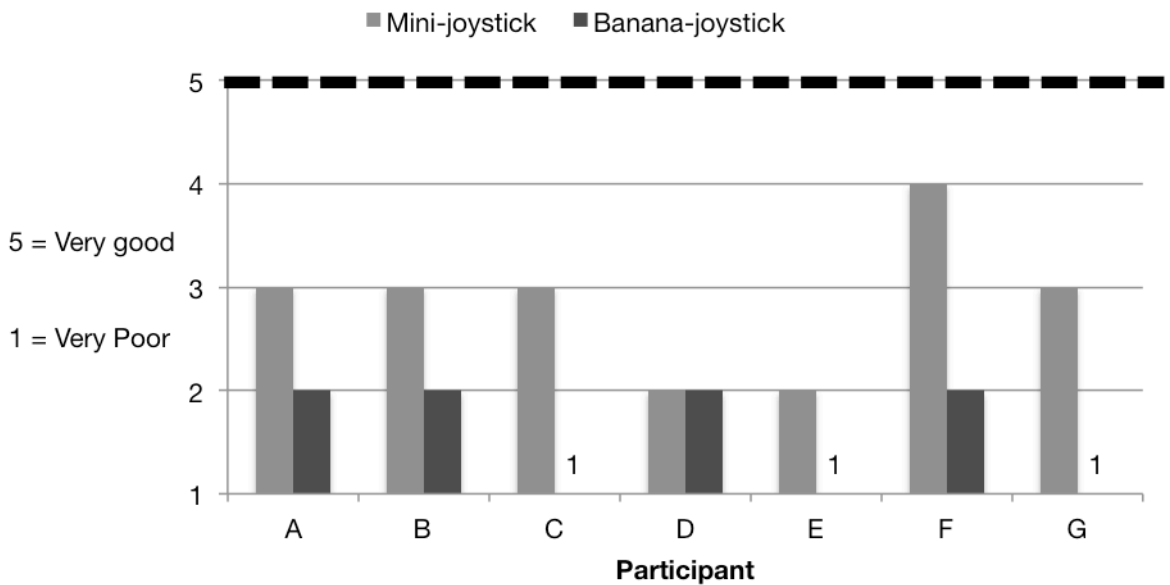

**Q7. How do you consider the feeling in the the lever, regarding the spring force?**

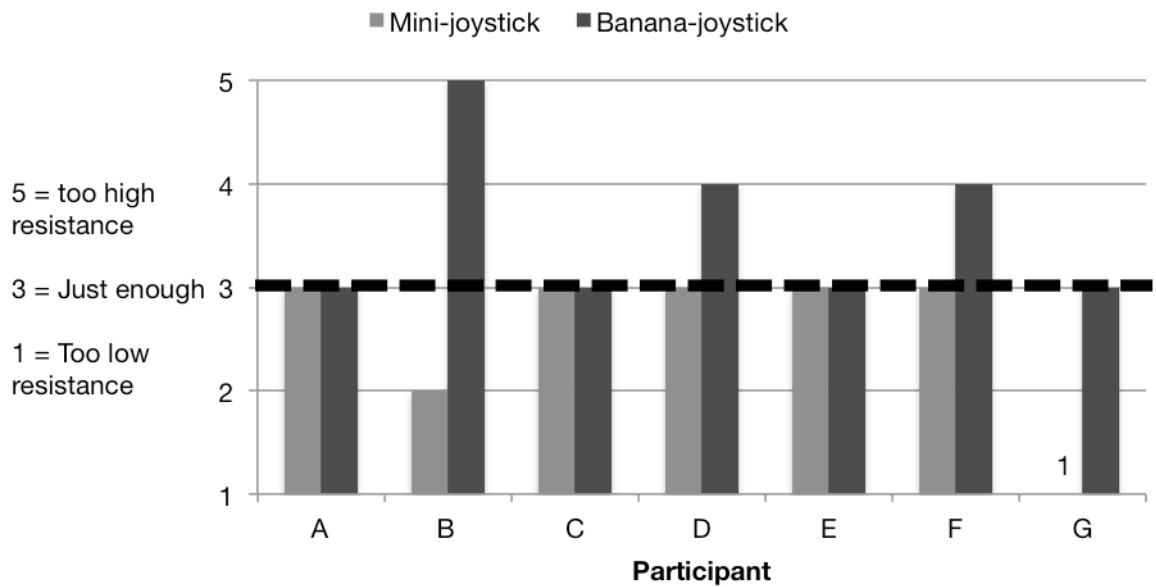

**Q8. How do you consider the feeling in the the lever, regarding the stroke length?**

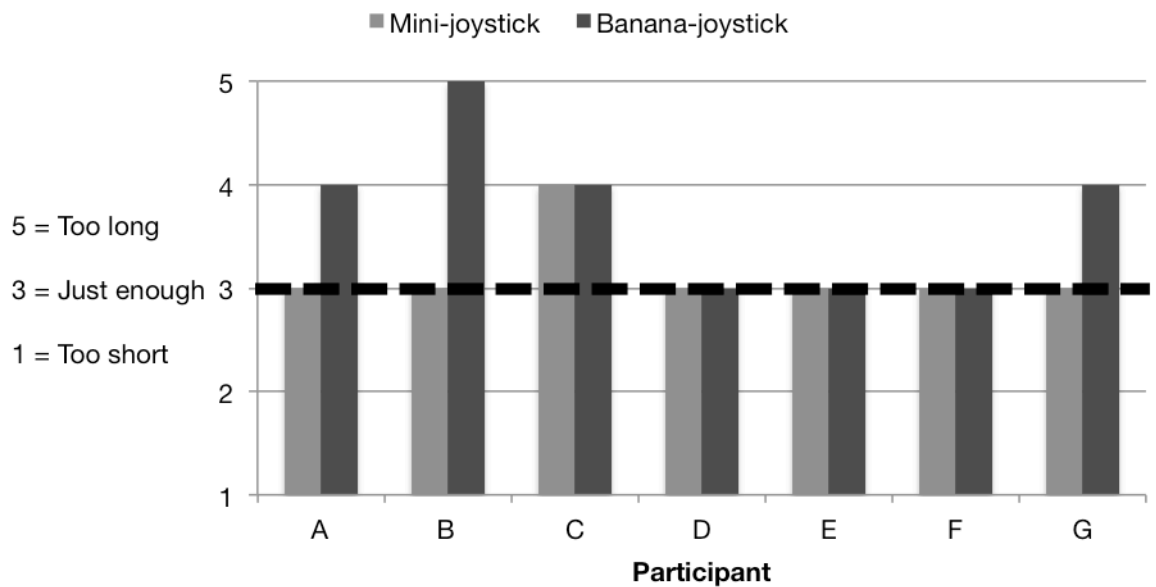



# Appendix VIII – Overall result

