

CHALMERS



Potential of biogas production from livestock manure in China

--GHG emission abatement from 'manure-biogas-digestate'
system

Master's Thesis within the Industrial Ecology programme

LIU GUO GUO

Department of Energy and Environment
Division of Energy Technology
CHALMERS UNIVERSITY OF TECHNOLOGY
Göteborg, Sweden 2010
Report T2011-353

MASTER'S THESIS

Potential of biogas production from livestock manure in China

--GHG emission abatement from 'manure-biogas-digestate' system

Master's Thesis within the *Industrial Ecology* programme

LIU GUO GUO

SUPERVISOR(S):

Erik Ahlgren

Christel Cederberg

EXAMINER

Erik Ahlgren

Department of Energy and Environment

Division of Energy Technology

CHALMERS UNIVERSITY OF TECHNOLOGY

Göteborg, Sweden 2010

Report T2011-353

ABSTRACT

With great change of food pattern on Chinese people's table, livestock production has been expanded to meet increasing demand of meat, egg and dairy products. Due to N_2O and CH_4 emission from ammonia utilization and untreated manure as well as CO_2 emission from large reliance on fossil fuels and traditional biomass, anaerobic digestion as a biological waste treatment technology to integrate energy system and agricultural system into manure management system, has attracted attention from public. Of special concern in this thesis is the setting up of 'manure-biogas-digestate' model and evaluating its GHG emission abatement compared to reference system.¹

Due to differences in livestock production, energy consumption pattern and agricultural land distribution, household biogas system and livestock farm-based biogas system are encouraged strongly in rural and suburb areas in China respectively. Aims of this thesis are to assess environmental benefits from manure treatment perspective, energy perspective and agricultural perspective of entire biogas system and to analyze whether biogas system implemented is a good choice to achieve the sustainability. Three steps are in focus to achieve the research aim:

- Calculating GHG emission abatement from household biogas system in rural areas and assessing which phase contributes to the most environmental impact;
- Assessing environmental impact through comparison between 'energy-environmental' biogas system and 'energy-ecological' biogas system.
- Doing future estimation of these two types of 'manure-biogas-digestate' systems with changes of energy consumption pattern and agricultural land area.

Through investigation of household biogas project in western China and livestock farm-based biogas project in east, the basic data used for assessing environmental benefits of two systems were collected. In household biogas system, CO_2 emission abatement is the largest in biogas substitution part but CH_4 is produced in large amount from uncovered anaerobic lagoon after anaerobic digestion (AD); As for livestock farm-based biogas system, AD selection and manure treatment process design play important role in the GHG emission mitigation potential, which are based on main purpose of project implement. Both energy substitution and agricultural land acceptable capacity are considered as constraint conditions of large-scale biogas system development.

Key words: Livestock manure management; anaerobic digestion; 'manure-biogas-digestate' system; future estimation; GHG emission abatement; household biogas system; 'energy-ecological' biogas system; 'energy-environmental' biogas system.

¹ Reference system is cited for comparing with 'manure-biogas-digestate' system. In household biogas system, the reference system is traditional household system, and in M&L farm-based biogas system, reference system is 'energy-environmental' biogas system compared to 'energy-ecological' biogas system

Contents

1. INTRODUCTION	1
1.1 Background	1
1.2 Aim of research	5
1.3 'Manure-biogas-digestate' system	6
1.4 Reasons to develop 'manure-biogas-digestate' system	15
2. METHODOLOGY AND DATA ASSUMPTION	23
2.1 Methodology	23
2.2 Data collection and assumption	29
3. CASE STUDY	34
3.1 Case study 1—household biogas system	34
3.2 Case study 2—Livestock farm-based biogas system	41
4. RESULTS	49
4.1 Results of GHG emission abatement and future estimation of case study 1	49
4.2 Results of GHG emission abatement and future estimation of case study 2	56
5. CONCLUSION AND DISCUSSION	63
5.1 Conclusion	63
5.2 Discussion	63
REFERENCE	FEL! BOKMÄRKET ÄR INTE DEFINIERAT.
APPENDIX	70

Abbreviation and definition

AD	Anaerobic digester
BOD ₅	Biochemical oxygen demand
CHP	Combine heat and power plants
CO ₂ - _{euq}	CO ₂ equivalent
COD	Chemical oxygen demand
DM	Dry matter of livestock manure
EBC	Emission from biogas combustion
EBP	Emission from biogas production
EF _{GHG}	GHG emission factor
ERES	Emission reduction from energy substitution
ERMM	Emission reduction from manure management
GHG	Greenhouse gas
MMS	Manure management system
RES	Reference energy system
SBR	Sequencing Batch Reactor Activated Sludge Process
TN	Total nitrogen
UASB	Upflow Anaerobic Sludge Blanket process
USR	Upflow Solids Reactor
VS	Volatile solid

Preface

In this study, two main parts are divided according to purpose of research. The paper work and calculation of energy perspective of research have been supervised by Erik Ahlgren at the Energy Technology division of Energy and Environment department in Chalmers University of Technology; The agricultural and livestock manure management part is guided by Christel Cederberg working in SIK in Gothenburg.

This part of the fieldwork has been carried out in Biogas Scientific Research Institute of the Chinese Ministry of Agriculture in Chengdu, Sichuan. All data for calculation of two scenarios were obtained from investigation of rural areas in Chengdu and livestock farm-based project in Inner Mongolia.

Finally, it should be noted that this master thesis could never have been conducted without the strongly help and high quality suggestion from my supervisors Erik Ahlgren and Christel Cedeberg as well as Professor Deng Liangwei from Chinese Biogas Scientific Research Institution, from whom I have learnt quite a lot knowledge beyond my education background. I also would like to thanks to my thesis opponent Zhao Lei who has given me valuable idea of paper work modification. Last but not least, I will express great appreciate to my parents who support me all the time during my study and the most tough time in my thesis research.

Göteborg September 2010

Liu Guoguo

1. Introduction

1.1 Background

China has a long history of livestock husbandry, and through the entire country, large differences in livestock production systems are found. These differences are based on temperature, climate, geomorphology, soil quality and population distribution. *Figure 1.1* shows the two main livestock areas, 'pastoral region' in north and west and 'agricultural region' in east and south. Between these two regions is a transitional area called semi-pastoral belt which is characterized by combination of pastoral land based livestock systems and arable farming based livestock system.



Figure 1.1 Map of distribution of pastoral region and agricultural region in China [1]

Pastoral region covers northern and western part of China, and animals such as sheep, horse, goat and cattle fed by grazing are found in this grass based livestock system. Most of areas in northwest and southwest of China are under harsh natural environment, which is more appropriate for grassland rather than arable land. The natural grassland in this region occupies over 75% of total pasture areas (300 million hectare) in China.

Agricultural region includes middle and eastern areas of China as well as Sichuan province in southwest. This region is characterized by intensive arable farming because the geomorphology, temperature and soil quality are suitable for crops, fruits and vegetables growth. Since population density is large in this region, the livestock husbandry patterns are decided by urban and rural location. Farming livestock areas dominate most of Chinese agricultural plants, which concentrate in Northeast, Huabei plain, Yangtze plain, Sichuan basin and Pearl River delta. The livestock productions

in these areas consist of pig, cattle and all kinds of poultries, of which pigs make up the largest part. And large share of these pigs are fed in ‘back yard’ of rural household. In additional, an increasing number of livestock industries with high level intensification are situated in suburbs of middle and big size cities in this region, especially dairy cow and poultry farm, to provide fresh dairy products, egg and meat to city residents.

1.1.1 Growth of animal products consumption

Over past 10 years, perhaps nowhere else than China has such huge “livestock revolution” occurred and the shift from diets based on vegetable foods to those much heavier in animal products been striking. Due to the rapid economic expansion, more Chinese enter the new middle class, and meat has moved from the side of the dinner plate to the centre. More meat and dairy products are demanded with economic development and nutrients requirement. During such short period, increase of pork and egg consumption has made China has become the world’s top producer of these animal products. *Table 1.1* and *Table 1.3* demonstrate the number of livestock slaughtered and animal products produced from 2004 to 2008 and *Table 1.2* illustrates the change of livestock in same period. During these five years, pig meat production has grown 1.06 times, and cattle and chicken meat have increased 11% and 16% respectively. With total meat production increased 10% from 2004 to 2008, of which pig meat production decreased from 65.5% to 63.3%, while chicken and cattle meat production percentage have risen from 14% to 15% and 7.8% to 7.9% respectively. What’s more, the increasing popularity of fresh milk results in immense increase in dairy cow numbers. From 2004 to 2008, 56.8% of cow milk production growth was with 41% increase of number of dairy cow. Meanwhile, the growth of number of pigs was accelerated with the same level of pork’s demands.

Table 1.1 Number of slaughter livestock in China (million head), 2004-2008 [2]

Livestock	2004	2005	2006	2007	2008
Cattle	40.03	40.66	41.58	44.05	43.57
Pig	584.6	615.3	623.8	576.4	620.8
Broiler	6898	7243	7202	7464	7759

Table 1.2 Number of livestock in China (million head), 2004-2008 [2]

Livestock	2004	2005	2006	2007	2008
Dairy cow	8.98	11.13	12.33	12.35	12.65
Other cattle	83.23	79	75.22	69.72	69.97
Pig	420.7	428.5	440.4	425.2	446.4
Broiler	4210	4294	4431	4505	4602
Layer	2135	2235	2305	2386	2487

Table 1.3 Production of animal products in China (million ton), 2004-2008 [2]

Production quantity	2004	2005	2006	2007	2008
Total meat	67.9	71.2	72.7	70.4	74.5
Cattle meat	5.3	5.4	5.5	5.9	5.9
Chicken meat	9.5	10.0	10.2	10.6	11.0
Pig meat	44.5	46.6	47.6	43.9	47.2
Cow milk	22.9	27.8	32.3	35.6	35.9
Hen egg	20.5	21.0	20.9	21.8	22.7

1.1.2 Increasing livestock manure

Increasing production of animal products results in increasing animal manure from the livestock. In 2008, Chinese livestock produced 2.7 billion tons manure totally, nearly three and a half times the industrial solid waste level. In *Table 1.4*, approximate values for N produced in manure (before any losses) and manure production from livestock per day are shown, all the data of which are based on Chinese resources [3] and Swedish default values from the software program STANK developed by the Swedish Board of Agriculture [4]. In *Table 1.4*, numbers of livestock in 2007 are provided by FAOSTAT database and total manure production and N in manure was calculated under Chinese context. Based on calculation of *Table 1.4* and *Table 1.5*, total N content of livestock manure in 2007 is around 10.7 Mt, which only include livestock categories, pigs, dairy cows, beef cattle, broiler and layer hens.

Table 1.4 Manure production from livestock (kg DM /head.yr) and N (kg N /head.yr) and P (kg P /head.yr) content in manure

Livestock categories	Manure production (Sweden)	Manure production (China)	N content (Sweden)	P content (Sweden)	N content (China)
Dairy cow 6000 kg milk/yr	2400	1524	100	15	68
Young heifer 0-12 month	425		20	2.5	
Young heifer 12-24 month	1000	920	47	7	30
Sow 12month	500		36	10	

Fattening pigs 2.5-3 batch/yr	160	135	3.7	0.8	4.6
Broiler 7 batch/yr	0.14	0.13	0.04	0.008	0.054
Layer hens 12month	11	14	0.52	0.17	0.57

Table 1.5 Total N and P content in manure (Mt) in China, 2007

Livestock categories	Number of livestock (Mhead)	N content	P content
Dairy cow	12.4	0.8	0.2
Other cattle	67.9	2	0.5
Pig (general)	597	2.7	
Sow	37	1.3	0.4
Fattening pigs	560	2.1	0.4
Broiler	7464	0.4	0.06
Layer hens	2386	1.4	0.4

Loss of N and P from untreated livestock manure can lead to severe environmental pollution. The N and P cycle are shown as followings [5]:

a. Nitrogen cycle

Figure 1.2 illustrates the nitrogen flow through agricultural, livestock system and environment. The excess N is lost to the environment via emissions, leaching and runoff. In the soil, ammonium from livestock manure and chemical fertilizers can convert into NO_3^- through nitrification which is mediated by the activity of nitrifying micro-organisms. However, not all the nitrified nitrogen is taken up by plants, some of nitrate is leached from soil and runoff to water which cause the aquatic system eutrophication. Besides this, ammonia in manure is evaporated to the atmosphere and this represents a significant N loss from agriculture. Ammonia contributes to eutrophication as well as acidification. In the nitrification process in the soils, NO_3^- can be denitrified into N_2O which is one of greenhouse gases leading to warming effect.

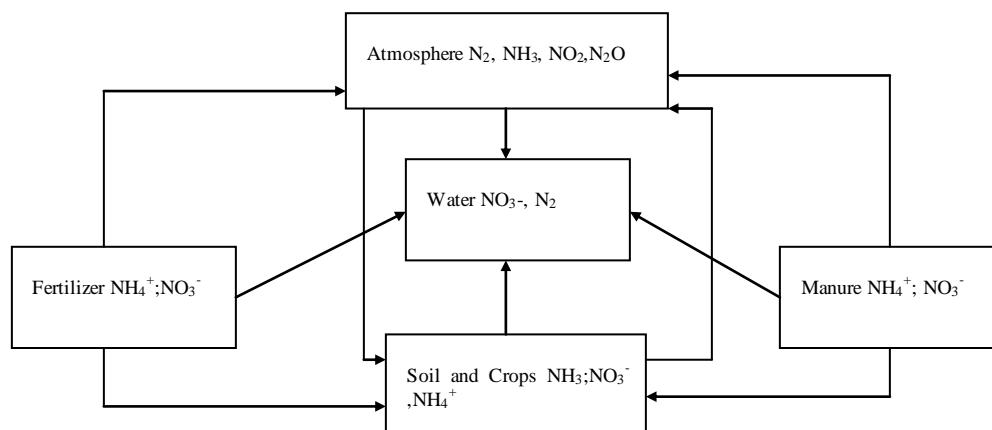

Figure 1.2 Overview of important N losses in agriculture

b. Phosphorus cycle

Phosphorous is lost from arable land by soil erosion, surface runoff and leaching (See Figure 1.3). One problem of today is that many agricultural soils have accumulated phosphorous in excess. Excess fertilization with P is not necessarily leached like the case is for nitrogen, but can go into the turnover of the various phosphorus types/compounds in the soil layers, whereof some are passive and/or only slowly converted to other forms. Adding more P than crop normal requirement results in high accumulation of P in soil, and it leads to the risk for future P leaching and increase the aquatic system eutrophication.

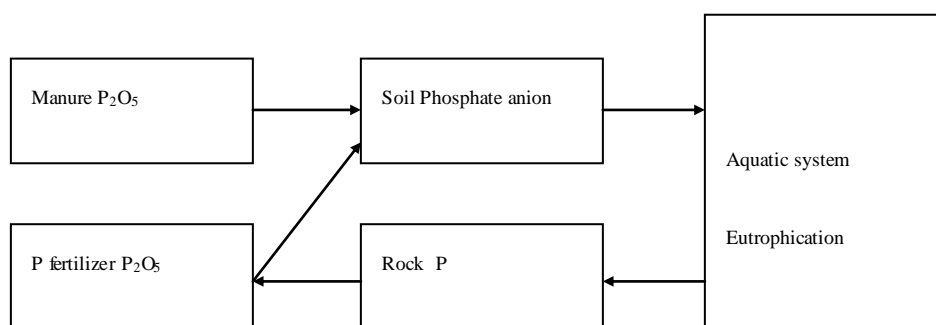

Figure 1.3 Overview phosphorous cycle in agriculture

1.2 Aim of research

Facing with increasing severely environmental problems from untreated livestock manure, ‘manure-biogas-digestate’ system is a new model to be built which integrates energy and agricultural system into livestock manure management system and environmental assessment of this model is done to evaluate whether large-scale biogas projects development with rapid growth in rural and suburb of China can achieve sustainability. In this thesis, GHG emission abatement from ‘manure-biogas-digestate’ system substitution is the only environmental evaluation parameter, and the other environmental impacts, such as soil erosion and water eutrophication resulted from N and P loss are not included here.

The GHG emission abatement is calculated by comparison between emissions from ‘manure-biogas-digestate’ system and reference system. However, due to different livestock husbandry patterns and biogas systems in rural areas and livestock farm, the ‘manure-biogas-digestate’ system implemented in rural areas is called ‘household biogas system’ and that in livestock farm is named ‘energy-ecological’ biogas system, from which the GHG emission abatement should be done as two separate scenarios as well. To household biogas system, the traditional household system² in rural area is selected as the reference system; As for livestock farm-based biogas system³,

² Traditional household system is formed by three parts, which are traditional manure treatment, traditional energy consumption pattern and traditional agricultural soil management.

³ In livestock farm-based system, ‘energy-environmental’ biogas system commonly used in most livestock farms is considered as a baseline to compare with ‘energy-ecological’ biogas system which is encouraged to develop in future.

reference system for comparison should be chosen as the traditional livestock manure treatment based on IPCC guideline. However, according to *Technical Specifications for pollution treatment projects of livestock and poultry farms* [6], the ‘energy-environmental’ biogas system is the most commonly used to instead of traditional manure treatment in Chinese M&L livestock farm at present. Hence, ‘energy-environmental’ biogas system can be assumed as the reference system of the ‘energy-ecological’ biogas system. What’s more, based on large amount of variable factors when assessing environmental benefits of biogas system, such as ingredients of feedstock, anaerobic digester, design of biogas production process, and digestate treatment and utilization, the GHG emission abatement of household and livestock farm-based biogas system should be assessed relying on the specific project. Three steps are in focus with rapid growth of biogas projects in large scale:

- To assess GHG emission abatement due to biogas systems compared with present situation of traditional household/farm-based system;
- To analyze which perspective of biogas system substitution has the largest GHG emission abatement through future estimation;
- To conclude the opportunities and challenges of future development of biogas system in Chinese livestock sector.

1.3 ‘Manure-biogas-digestate’ system

The anaerobic digestion becomes an increasingly attractive manure management technology by multiple benefits from the process and it is adopted in both household and medium and large (M&L) livestock farm. Livestock manure is collected concentrate and treated in anaerobic digester which can protect ammonia and methane from emitting to atmosphere, and reduce the amount of nutrients to rush into groundwater resulting in aquatic system eutrophication. Meanwhile, biogas and digestate produced from anaerobic digestion process can be seen as renewable energy fuel and organic fertilizer to substitute of fossil fuel and industrial fertilizer in energy and agricultural systems. Therefore, biogas is now widely integrated with animal husbandry and become an important means of manure treatment in agricultural sector.

1.3.1 Anaerobic digestion technology

1. Scientific theory of anaerobic digestion

Anaerobic digestion depends on consortia of hydrolytic and acidogenic bacteria working with methane producing bacteria (methanogens) growing in structured colonies or films for structural support and metabolic interchange. Four stages of chemical reaction in anaerobic digester is shown in *Figure 1.4*.

	Process	Bacteria	Output
I	Hydrolysis	Anaerobic hydrolysis bacteria	Monosaccharides, amino acids and fatty acids
II	Acidity increase	Acid formers	Organic acids, carbon dioxide
III	Acetic acid formation	Acetic acid formation bacteria	Acetic acid, carbon dioxide, hydrogen
IV	Methane formation	Methane bacteria	Methane, carbon dioxide, water

Figure 1.4 Four stages of chemical reaction in anaerobic digester [7]

- 1st stage Hydrolysis: In this stage, aerobic bacteria reconstructs high-molecular substance (protein, carbohydrates, fats and cellulose) by means of enzymes to low-molecular compounds like monosaccharide, amino acids, fatty acids and water.
- 2nd stage Acidogenesis: This stage is made by acid-forming bacteria, which separate molecules penetrate into bacteria cells. In order to process well in next stage, this process is partially accompanied by anaerobic bacteria that consume rest of oxygen to provide appropriate environment for methane bacteria. Acids, alcohols and gases (carbon dioxide, hydrogen sulfide and ammonia) are produced.
- 3rd stage Acetogenesis: Acetic acid is produced in this step for methane formation.
- 4th stage Methanogenesis: This is the last step in anaerobic digestion process, which produces methane, carbon dioxide and water. 90% of methane yield takes place here and 70% of it from acetic acid.

With all biological processes, the constancy of the living conditions is of importance. A temperature change or changes in the substrates or the substrate concentration can lead to shutdown of the gas production. The microbial metabolism processes are dependent on many parameters, so that, for an optimum fermenting process, numerous parameters must be taken into consideration and be controlled. The environmental requirements of biological process are shown in Table 1.6. [8]

Table 1.6 Parameters of biogas production during 4 stages of anaerobic digestion

Parameter	I-III stages	IV stage
Temperature	25-35°C	Mesophilic:32-42°C; Thermophilic:50-65°C
PH value	5.2-6.3	6.7-7.5
C:N ratio	10-45	20-30
DM content	<40% DM	<30% DM

Required C:N:P:S ratio	500:15:5:3	600:15:5:3
------------------------	------------	------------

2. Biogas production from anaerobic digestion

Biogas contains mainly CH₄ (60%-70%), which is the same energy carrier as in natural gas. So, biogas and natural gas can be used in same application. Methane can be burnt for cooking or lighting the house. It can also be used to power combustion engines to drive a motor or generate electricity. Strictly speaking, biogas production is proportional of the volatile solids (the organic matter) content of the feedstock, but to a good approximation may be considered proportional to the dry matter (DM). Normally, DM of raw materials should be kept around 10%-12%. [9] If substrate is so thick, crust will be formed above liquid surface; if the DM is low, the biogas cannot be produced with inefficient VS content. Biogas plants are used to ferment liquid manure, at present, quite often combined with co-substrates to increase the biogas yield, for example municipal organic waste, food waste, slaughter house waste and other crop residues. In China, the most common used additive raw material is rice straw. The biogas yield from livestock manure and other raw materials are shown in Table 1.7 and Table 1.8 shows the biogas yield from different raw materials.

Table 1.7 Biogas production of livestock manure per head (m³ /head.day) [10]

Livestock categories	Fresh manure (kg/head.day)	DM %FM	oDM %DM	Biogas producing rate m ³ /kg DM	Biogas yield m ³ /head.day
Dairy cow	25-30	16.7	74	0.2-0.25	0.83-1 1.05-1.25
Pig	1.5-2.5	18.5	83.9	0.25-0.3	0.07-0.12 0.08-0.14
Poultry	0,1-0.12	30	82.2	0.3-0.35	0.009-0.011 0.011-0.013

*Lower data is related to fermentation temperature 15 °C and higher one is 25 °C

Table 1.8 Biogas yield from different raw materials for biogas production [11]

Raw materials	Estimate DM (%)	Best estimate of biogas yield (GJ/DM)	Low value of biogas yield (GJ/DM)	High value of biogas yield (GJ/DM)
Ley crops	23	10.6	5.3	13
Municipal organic waste	30	12.4	10	14
Slaughterhouse	17	9.4		

waste				
Tops and leaves	19	10.6	7.8	14
Straw	82	7.1	5.6	8.5

3. Digestate production from anaerobic digestion

- Solid residue

During fermentation of livestock manure, pathogen can be killed under anaerobic environment, and biogas residue, an organic fertilizer with high quality is produced. The chemical forms of N and P in residue are easier to be utilized by plants in short time than those in other manure management system, such as compost. For instance, in residue, organic matter content is around 28%-50%, humic acid content is about 10%-20%, cellulose content is 13%-17%, N content is 0.8%-20% and P content is 0.4%-12%. [12] It is estimate that, continuous use of residue for six years can obviously enhance the water retention of soil and improve its physical properties.

- Liquid effluent

Slurry is another by product of biogas production, which is constituted of three kinds of bioactive substances. And all of these elements play an important role in maintaining plant's normal growth. Slurry is different from solid residue, since it can be irrigated at farms, to vegetables, fruit and other plants directly. However, due to N and COD contained in slurry, the amount of it should follow the national regulation of farm irrigation depending on plants categories.

1.3.2 Two types of 'manure-biogas-digestate' systems

There are two types of 'manure-biogas-digestate' systems in China. The first is based on household livestock husbandry which mainly focuses on the small-scale animal production in household of rural areas. The farmers that live in rural areas raise several animals in their own backyards, which are mixed breed in this type, for instance, 2 pigs, 1 cattle and 4-5 chickens per farm. The production system is quite common in China because of large population in rural areas. The areas in China which are right for developing the household livestock husbandry pattern are mostly located in under developed areas, like north-western China, south-western China and north-eastern China. The second type is based on intensive livestock production systems which includes medium & large-scale (M&L) livestock farms. The areas appropriate for this type are suited in east-coast of China and most suburbs of middle and big cities. *Table 1.9* shows the distinction between these two livestock husbandry patterns based on number of livestock breed.

Table 1.9 Number of livestock in livestock farm and household husbandry system (head) [13]

livestock	M&L-scale livestock production system	Small-scale livestock production system
-----------	---------------------------------------	---

	Medium-scale	Large-scale	I	II
Pig(S)	50-2999	≥ 3000	1-9	10-49
Cow(T)	21-199	≥ 200	1-5	6-20
Cattle(S)	51-499	≥ 500	1-10	11-50
Layer(T)	2001-49,999	$\geq 50,000$	1-49	50-2000
Broiler(S)	2001-99,999	$\geq 100,000$	1-99	100-2000

**Number of pig and cattle in both husbandry patterns are calculated as the slaughter number per year; Cow and layer are calculated as stock number per year (both animals can stay in farm the whole year); Broiler in intensive livestock husbandry is calculated as slaughter number per year while the dispersed type is not.*

1. Household biogas system

● Household biogas digester

In household biogas digester, feedstock used in anaerobic digesters of household biogas production system depends on what organic wastes are produced by rural families. Generally, food waste are often consumed by pigs or poultries, and the feedstock for generating biogas always includes human and livestock manure as well as crop residues. However, crop residues are high in fiber which is hard to break down and intend to form crust inside the digester, except for its function of adjusting C/N ratio in digester. Hence, livestock, human manure and food waste are the best option as input to produce biogas. In commonly used Chinese household digester design, effluent chamber and anaerobic reactor are connected and toilets and pigsties are connected to influent port. Both gas storage room and fermentation room occupy 15% and 85% of total volume of digester respectively. [14] The head space volume above the reactor leads to gas pressure delivered into the home; it is affected upon effluent port liquid level. Hence, separate gas storage chamber is constructed in some systems. In rural areas of China, the waste from both pigsties and toilet are flush into reactor directly. And in order to remove effluent periodically, a vertical cylindrical pull-rod port is added at the side of the effluent port. Effluent is removed by moving a pull-rod up and down in the port. The pull-rod is simply a wooden shaft with a metal disk on the bottom. This facility is also operated by hand. There are three common types of household biogas system developed in Chinese rural areas depending on their local climate and natural environment. The detailed information is concluded in *Table a* in *Appendix 1*.

● Biogas utilization of household biogas system

At present, 60% of China's population live in rural area China. In the long term, rural household energy consumption in Chinese rural areas mainly depend on traditional

biomass energy and fossil fuels, in which straw account for 34%, fire wood account for 24% and coal cake stood for 32%.[15] In the past, energy used for heating and cooking was provided by biomass resources combustion, which leads to low energy efficiency and severely environmental degradation. When burning firewood and coal cake in traditional stove, the smoke contains CO₂ and SO₂ which result in enhanced greenhouse gas effect and acid rain. Apart from that, coal is facing the danger of exhaustion and large demand of firewood leads to uncontrolled tree cut and risk of degrading land. According to China's rural biogas planning project (2006–2010) [13], by 2010, 139 million rural households are suitable for further development of biogas project. Compared with past 15 years, total energy from biogas production is equivalent to 2.84×10⁷ tons coal which leads to 7315.7 Mt GHG emission reduction.

- Digestate utilization of household biogas system

This slurry produced from household anaerobic digester cannot only be used as agricultural fertilizer but also as a feed supplement for pigs, mushroom growing substrate, fertilizer for fish ponds and substrate for rearing worm and soaking seeds. The waste sludge produced at the bottom of reactor can be used as fertilizer after composted in the field. Using anaerobic reactor effluent instead of industrial fertilizer increased a field's net economic yield by 30% [16]. What's more, anaerobic effluent used in mushroom production increases yields by 30%, increase fish production by 6-12% and reduce the cost of breeding pigs. [16]

With the urbanization, more farmers rush into the cities. According to government target, in 2020 the biogas utilization ratio in total rural areas will achieve 38.4%, which is more than twice times than that in 2010. And 70% of potential household will establish the biogas plants at home. See from *Table 1.10*, western China is in the top of household biogas project development. As for eastern China, due to rapidly urbanization in this region, potential household for biogas project is reduced with rural households shrinking. The percentage of potential household for biogas projects to total rural areas in eastern China is 37% and estimate biogas plants are only 6% of total.[13]

Table 1.10 Household biogas projects distribution and development in 2010

Region		Total rural household (million)	Potential Household biogas (million)	Biogas plants (million)	Biogas system type
Western China	Southwest	49.68	39.1	14.53	3 in 1 ⁴
	Northwest	17.68	10	4.14	5 in 1 ⁵

⁴ 'Three in One' eco-agricultural model, which combining the biogas digester with a pigpen and toilet, is popular in eastern and southern of China. The provinces included in these two districts are Jiangxi, Hubei, Hunan, Hainan, Jiangsu, Zhejiang, Fujian, Shandong, Guangdong, Tianjin, Shanghai and Beijing.

⁵ The 'four in one' eco-agricultural model, which combines the biogas digester, pigpen, solar greenhouse and toilet, can solve the problem of conventional greenhouse model to meet the energy and environmental requirement. The greenhouse in this model can be used to increase the temperature of biogas digester when it is on operation, besides the plants and livestock demand. This model is common used in north part of China with cold temperature.

	Others	8.31	6.26	1.36	
Mid & Northeast China	Southeast	23.77	18.62	6.82	3 in 1
	Yellow-Huai sea plain	60.29	35.24	7.8	4 in 1 ⁶
	Northeast	10.48	5.25	1.64	4 in 1
Eastern China		65.8	24.54	3.89	3 in 1

2. Livestock farm-based biogas system

- Medium and Large farm-based biogas digester

In M&L livestock farm-based biogas projects, selection of anaerobic digest device should be based on raw material, temperature, energy recovery, and post-treatment process. The ingredients and concentration of raw materials should be taken into consideration in the first place when choosing the appropriate anaerobic digester, in which the quantity of raw material per day, moisture content, COD and BOD₅ content as well as other physical condition (PH and temperature) are included. Due to the introduction above, the biogas production efficiency is represented by the volumetric biogas producing rate which results from organic volumetric loading rate multiply with raw material biogas producing rate [17]. Hence, improving the materials transferring between the microbes and substrate or remaining amount of anaerobic microbes in the reactor are important for selection of anaerobic digester.

- Biogas utilization of M&L farm-based biogas system

Biogas produced from livestock farm manure transported to residents living in suburb is the most common way of using the energy from biogas production. On large livestock farms, biogas can replace heat and electricity used for livestock operation, e.g milking and cooling. For example, biogas can be burned in boilers without any pretreatment of the gas besides the removal of water and H₂S and the heat it produced can keep warm of animal living places especially under low temperature in winter. What's more, biogas produced from large-scale biogas plant on livestock farm intends to generate electricity through electricity turbine, from which heat generated partly escapes with the exhaust gas and has been recovered in heat exchanger for further use. Since the exhaust gas is at the minimum temperature of 120-180°C, the heat cannot be completely transferred to water in cooling water heat exchanger. The heat losses of entire biogas plant cannot be avoided. Biogas production is continuous through the whole year, which will provide excess heat demand during summer. Any excess gas is suggested to be flared off to reduce emission of methane. Most biogas digesters are heated by combustion of excess biogas generated themselves. Several electricity engines are available in market, such as diesel engines, stirling engine and gas turbine. The energy efficiency of biogas cogeneration is high and corresponds to about 34% of electrical energy and 57% of heat energy with 9% of total energy loss [18]. However,

⁶ The 'Five in One' eco-agriculture model, which combines the biogas digester with solar-powered barns, water saving irrigation system, water cellar, and toilet, is proposed for Northwest China with rare water resources.

electricity generation from biogas in China is not as popular as that in Europe, because of weak economic support from government and low revenue for electricity. Apart from the local direct conversion of biogas to electricity and heat, biogas can be used for feeding into the natural gas network. To be distributed on the natural gas grid, biogas needs to be upgraded. CO₂ and mainly H₂S contained in biogas have to be removed in order to increase the heating value. Odorants are added to make leakage traceable, and heavy hydrocarbons are added to increase biogas quality.

- Digestate utilization of M&L farm-based biogas system

Digestate includes both solid residues and slurry. The solid residue consists of the mineralized remains of the dead bacteria from the digesters and lignin that cannot be broken down by the anaerobic microorganisms. Hence, compost solid residue from digester is following. Lignin and other materials are available for degradation by aerobic microorganisms to nutrients, which is more suitable as a soil improver [19]. The liquid slurry through anaerobic treatment is disposed by removing majority of the large solid. This effluent is rich in nutrients which is suitable for irrigation for field. However, If the digester is situated far away from agricultural land where the digestate can be used substituting fertilisers, the volatile matters left in the liquid needs to be purified in, aerobic treatments which is regulated under environmental law in China. ‘Energy-environmental’ biogas system and ‘energy-ecological’ biogas system are accepted by most of M&L livestock farm. The former one is commonly adopted in the surrounding of digestion system which is without any farm or fish pool nearby, and the liquid from digester is required to be treated in aerobic tank to remove most of active chemicals; The latter one is used for the opposite situation, in which the effluent with rich nutrients can irrigate to farm or pure into fish pool after sediment from digester.

Compared to small-scale intensive livestock husbandry pattern, medium and large livestock farm has larger biogas potential. It is not only due to its abundant raw materials but also because of reduction of negative environmental impact from manure treatment on farm. According to ‘Five years plan’ from Chinese government, east China with highest population density has the largest potential of medium and large scale livestock farm biogas system development. As seen in *Table 1.11*, it is estimated that M&L scale biogas projects in eastern areas will achieve a total number of 2393 in 2010, which represents 48% of all M & L livestock farms in the same region and 51% of total M & L livestock biogas projects. [13] Compared to west and middle of China, eastern areas consists of many large cities which results in loss of agricultural land due to urbanization. With more biogas projects developed on livestock farms in these urbanized areas, large amount of digestate produced must be irrigated on arable land in short time. However, if the distance is long to agricultural land, the digestate cannot be used and instead have to be purified through aerobic lagoon and all the nutrients contained in digestate can’t be used in agriculture to replace of industrial fertilizer.

Table 1.11 Livestock farm biogas projects distribution and development in 2010

		M & L scale livestock farm, 2005	M & L scale biogas project, 2010 ²	Ratio ¹ (%)

Western China	Southwest	852	236	27.7
	Northwest	689	219	31.79
Mid & Northeast China	Southeast	1522	489	32.13
	Yellow-Huai sea plane	2313	793	34.28
	Northeast	1602	570	35.58
Eastern China	Rural areas of east coast	4974	2393	48.11

*1. $Ratio1 = \text{medium \& large scale biogas project} / \text{medium and large livestock farm}$;

2. According to the Chinese report, the M&L scale livestock farm in 2010 remain the same number as that in 2005.

3. Comparison between these two biogas systems

Based on the introduction of household biogas system and M&L livestock farm-based biogas system, the comparisons between these two systems are concluded in the *Table 1.12* below:

Table 1.12 Comparison between household biogas system and M&L livestock farm biogas system

Item	Household digester	M&L farm-based biogas plants
Purpose	Energy & sanitation	Energy& environmental
Digested effluent	Fertilizer	Fertilizer, aerobic post-treatment
Power input	None	Yes
Fermentation facilities	Simple	Facilities of purification, storage and distribution of biogas, CHP facilities and auto-controlling instruments
Installation	Underground	On the ground
Design& Construction	Simple	Joint of specialty of process, structure equipment, electric and auto-controlling

		instruments
Operator	None	Professional operator
Biogas producing rate	0.1-0.3m ³ /m ³ .day	0.3-10m ³ /m ³ .day

1.4 Reasons to develop ‘manure-biogas-digestate’ system

In the past, agriculture, livestock husbandry and energy were three independent sectors in China. People know the relation among them but used to neglect how they interact with each other. When facing with increasing concern on the environmental issue and coming energy crisis, Chinese government make great efforts to change traditional life pattern into sustainable one. Reasons to develop ‘manure-biogas-digestate’ system are due to positive environmental impact from reduction of industrial fertilizer use from agricultural perspective, substitution of fossil energy fuel from energy perspective and improvement of manure management system. The GHG emission from ‘manure-biogas-digestate’ and relation between each of them are shown in *Figure 1.5*.

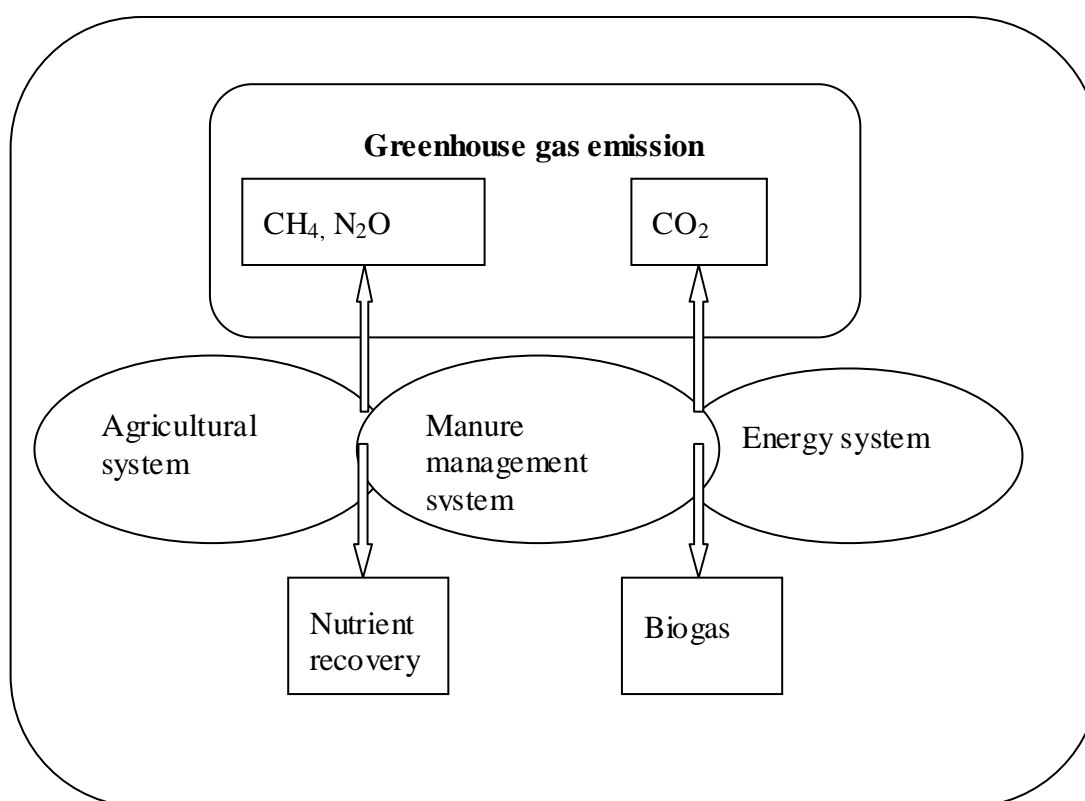

Figure 1.5 Environmental benefits from ‘manure-biogas-digestate’ system

1.4.1 Environmental benefit from manure management system

1. Substitution of traditional manure treatment

Manure treatment is divided into two categories, one is untreated manure which means the farmer use fresh manure as fertilizer directly without any treatment; most of these farmers in rural areas don't have any manure treatment; the manure is spread immediately or stored in simple constructions. In suburb regions, most of modern medium and large scale farms are located and since the manure is mostly untreated, this leads to severe environmental pollution problem through runoff of nutrients to water bodies and emissions to air of ammonia; For instance, 'dead zone' in the South China Sea is virtually devoid of marine life due to eutrophication problem, in north, overgrazing to satisfy the needs of large amount of livestock, lead to the loss of nearly a million acres (about 400,000 hectares) of grassland each year to desert.[20]. The other is treated manure, which also can be divided into two types according to their energy recovery. Composting manure and slurry/liquid storage don't have any energy recovery from treatment, the products from this process is only the composted manure which is used as a fertilizer and soil improver. Manure treatment with energy recovery includes combustion and anaerobic digestion. Combustion of manure has the limitation that manure should be in high fiber content but little moisture. Cattle, sheep and horse manure are more suitable for this treatment than pig and poultrys. However, drying manure is a precondition of combustion which aims to lowering moisture, but consuming fossil fuel to provide thermal. What's more, energy conversion efficiency is not high and a lot of smoke with S and CO₂ is emitted. Hence, manure treated by combustion is not common used in China, besides the pastoral areas. Different manure managements common used in China are shown in *Table 1.13*. [21]

Table 1.13 Definition of common manure management system in China

System	Definition
Solid storage	Manure is stored in unconfined piles periodically.
Liquid/slurry	Manure is stored as excreted with minimal water added and always stored in tanks or ponds. This manure management system is the most commonly one in rural China.
Composting	Composting manure is a naturally occurring process that farmers have used for centuries in China. Under the aerobic conditions, microorganisms grow and multiply, converting the original organic material into a more stable, usable product.
Anaerobic digester	Anaerobic digester is designed and operated for waste decomposition by microbial reduction of complex compounds to methane and carbon dioxide. Methane can be used as fuel with high heat value and digestate produced from digestion process can be used as organic fertilizer to agricultural plants.

Due to N, P and other nutrients are in large numbers in manure and especially if the manure is spread when there is no crop growing in winter, severe problems can arise when water bodies become over-enriched by excessive nutrient input and consequently polluted. Moreover, some antibiotic residues and pathogens are left in livestock manure that is not treated. These will make negative effect to people's health when emitting to the air. And odor from ammonia in manure will destroy people's living environment.

1.4.2 Environmental benefit from agricultural system

1. Substitution of increasing demand of industrial fertilizer by digestate

Because arable land is reduced by construction and urbanization, land must be expanded, and crop yields must be improved. *Table 1.14* indicates the yield of wheat, rice and maize between 2007 and 2008.

Table 1.14 Yield of wheat, rice and maize per harvest area (ton/ha), 2007-2008 [2]

Year	Wheat harvest	Rice harvest	Maize harvest
2007	4.3	5.8	4.9
2008	4.2	6.1	5.1

Along with increasing of crop yield and food quality, more fertilizer and pesticide are needed in agricultural sector. According to Y.FO (2001) [22], in China, areas for cropping account for 70% of total arable areas, which includes both crop and economic agricultural plants, such as cotton. In 1999, total area of arable land in China was 130 million hectare and real cultivation area is 200 million hectare depending on double cropping. 70% of 200 million hectare (140 Mha) is used for agricultural crops, not including permanent crops such as fruit, tea and also cotton. This area is estimated to keep stable in following years. At the end of 1999, total crops productions were 500 Mt in China. If the average crop demand per people remains 400 kg per year, till 2010, the total crops production in China will increase up to 552 Mt in order to satisfy demands of 1.38 billion populations. Hence, yield of crops have to be improved by using fertilizer. *Table 1.15* shows the estimate of crops production and fertilizer consumption in 2010, 2015 and 2030. [22]. the fertilizer consumption in 2010, 2015 and 2030 will increase continuously.

Table 1.15 Estimate of crops production and fertilizer consumption in China, 2010, 2015 and 2030

	1999	2010	2015	2030
Cropping areas (billion hectare)	0.14	0.14	0.14	0.14
Total crop production (Mt)	500	552	576	640

Population (billion)	1.25	1.38	1.44	1.6
Crop yield (t/ha)	3.5	3.9	4.1	4.6
Amount of fertilizer added (Mt)	----	5.6-7	8.4-10.5	15.4-19.6
Total fertilizer consumption (Mt)	24.75	30.35-31.75	33.15-35.25	40.15-43.35
Fertilizer per hectare (kg/ha)	176	217-227	237-252	287-310

In addition, based on another experiment from national fertilizer website from 1980 to 1993, [23] if crop yield per harvest land is expected to achieve 5-6 t/ha, the most appropriate N fertilizer consumption is 150-180 kg N/ha and P fertilizer is 40-70 kg P₂O₅/ha in China. Compared to Europe, this fertilizer consumption is quite high. Meanwhile the ratio of different nutrients in mixed fertilizer N:P₂O₅:K₂O is suggested to adjust as 1:0.4-0.45:0.25-0.3 and total fertilizer input per harvest area shouldn't exceed 300 kg/ha. Fertilizer consumption per arable land in 2007 is shown in *Table 1.16*. When compared to suggest N and P fertilizer consumption per hectare, it is clear to see that N and P fertilizer consumed per arable land in 2007 had exceed the recommended value.

Table 1.16 N and P fertilizer consumption per arable land in China (t/ha), 2007

Year	Arable land (Mha)	N fertilizer consumption (kg N/ha)	P fertilizer consumption (kg P ₂ O ₅ /ha)
2007	140.63	230	80

In most of arable land, farmer commonly use more fertilizer than normal demand of crops in order to increase its yield in short time. However, nitrogen evaporates into atmosphere and phosphorous accumulate in soil in large amount which leads to nutrients losses both in short and long term. For instance, in Huabei plain, settlement of nitrogen in atmosphere achieves 60-80 kg N/ha, which accounts for almost 30% of N demand of crops normal growth per year [24]. Meanwhile, accumulation of nutrients in soil occurs after more than 20 years continuous fertilization. Based on investigation of 140 farmers in Huabei plain, nitrogen accumulation in soil is up to 280 kg/ha, which is more than crops normal nitrogen needs 200 kg/ha. From 1977 to 2005, chemical fertilizer consumption in China has increased 700% but yield of crops is only 71% rise at the same time. Meanwhile, coal used for producing more fertilizer leads to GHG emission besides water pollution caused by overuse fertilizer. [25]

According to report [26], the average annual growth rate of N₂O_{-direct} emission from agricultural soil of China is 7.6% for 1980-2007, releasing 0.3 Mt N in 2007. The contribution of industrial nitrogen fertilizer, organic fertilizer, crop residues and histosol soils to N₂O_{-direct} emission from agricultural soil of China are 77.64%,

15.57%, 6.64% and 0.33% respectively in 2007 (See *Table 1.17*). The data in the report represents that industrial fertilizer is the main source of N₂O emission from soil. From 1980 to 2007, contribution to N₂O emission by chemical fertilizer consumption increased from 57.22% to 77.64%, with decrease of organic fertilizer input by 53.1%. Amount of nitrogen loses to environment is tightly related to N efficiency of chemical fertilizer and organic fertilizer.

Table 1.17 Contribution of impact factors of N₂O-direct emission from agricultural soil in China (%) [26]

Year	Contribution of industrial fertilizer	Contribution of organic fertilizer	Contribution of crop residues	Contribution of histosol*
1980	57.55	33.23	8.20	1.01
1985	66.98	23.56	8.73	0.74
1990	73.09	19.08	7.30	0.53
1995	75.21	17.54	6.83	0.42
2000	76.41	16.70	6.51	0.38
2005	76.27	16.89	6.50	0.34
2007	77.64	15.57	6.46	0.33

*Histosol is a soil comprised primarily of organic materials. They are defined as having 40 centimetres or more of organic soil material in the upper 80 centimetres. Organic soil material has organic carbon content (by weight) of 12% to 18 %, or more, depending on the clay content of the soil.

Besides the direct and indirect GHG emission from industrial fertilizer and nutrients leaching from soil, the emission from fertilizer production also needs to be considered. Demand for coal in synthetic ammonia has grown with fertilizer consumption increased. 3% of total coal consumption is chemical sector in 2005 of which fertilizer production represents 60% of that in 2006 [27].

1.4.3 Environmental benefit from energy system

1. Substitution of traditional energy fuel

According to Shi and Zhao (1999) [28], China's total energy consumption is projected to increase from about 920Mt-oil equivalent in 2001 to 1,550 Mt-oil equivalent in 2015. The implied average annual rate of growth is 5.1% during 2001-2005 and 3.1% during 2005-2010. *Table 1.18* shows the estimate of China's primary energy consumption from 2005 to 2010. [29] The consumption will vary across the regions in China. The eastern coast regions will still lead the energy growth in China and residential sectors will likely be the sectors contributing to China's increased energy consumption in the future. Through comparison between different energy fuels in market, coal consumption is estimated to be declined from 67% to 65.3% from 2005 to 2010, while crude oil will increase from 22% to 24% and natural gas will rise up to

3.4% from 3.2% in the same period. Although the coal consumption will decline after 2005, coal still dominates Chinese energy market, especially in power and heat generation sector. By 2005, the share of primary coal use going to power and heat generation was over 57% of total consumption, of which power generation accounts for 90%. 3% of coal is consumed in chemical sector and 60% of it is used for producing industrial fertilizer. It is predicted by the China coal transport and marketing association that domestic coal demand during 2006-2010 will grow about 3-5% per year, which is 2-3% higher than that during 2010-2020. [27] However, due to gradually increase of coal price, demand for natural gas is expected to grow faster. The Chinese Academy of social sciences predicts that, in the next 15 years, China's demand for natural gas will grow at an average annual rate of 11-13%.

Table 1.18 Estimate of China's primary energy consumption from 2005 to 2010 (million ton-coal equivalent) [28]

Year	Coal	Crude oil	Natural gas	Total
2005	1215.9	402.9	54.1	1806.3
2006	1245.1	417.5	57.8	1858.8
2007	1274.1	435.4	61.6	1914.3
2008	1311.1	457.6	65.5	1982.6
2009	1359.7	485.4	69.4	2068.5
2010	1421.1	519.5	73.3	2173.5

● RES of rural areas in China

As the biggest developing country, China has large population living in rural areas which is around 60% of total. Although energy consumption in rural areas of China is much less than that in urban, GHG emission from rural energy sector cannot be neglected because of their energy sources. In rural areas and other remote places, coal and traditional biomass energy play major roles in domestic energy consumption. Based on L, Junfeng (2005) [30], in 1997, rural traditional biomass fuel consumption, such as straw and firewood account for more than 30% of total rural energy consumption, of which energy used for domestic purpose occupied 60%. In domestic energy consumption in rural community, heating space and household cooking as well as light are the basic needs of people, of which cooking demand accounts for 90%. (See *Figure 1.6*). In 1999, the total residential energy consumption is 10261 PJ, of which 2003 PJ is from urban and 8259 PJ is from rural, corresponding to share of 20% and 80% respectively. [31] Although total residential energy consumption from 1991 to 1999 reduced gradually with economic development and energy sources changes, increasing quantities of traditional biomass fuel such as straw and firewood are used in rural residential houses for cooking and space heating with lower energy conversion efficiency. In *Table 1.19*, the allocation of different energy sources used in rural China in 2005 are shown. Straw, firewood and coal occupy nearly 90% of total rural energy consumption.

Table 1.19 Allocation of fuels consumption in rural areas in China, 2005 (%) [15]

Energy fuel	Straw	Firewood	Coal	Elec	Oil	LOG ¹	Natural gas	Coal gas
Share of fuel consumption	33	24	32	7.4	2	0,9	0.4	0.3

*1. LOG—Liquid oil gas;

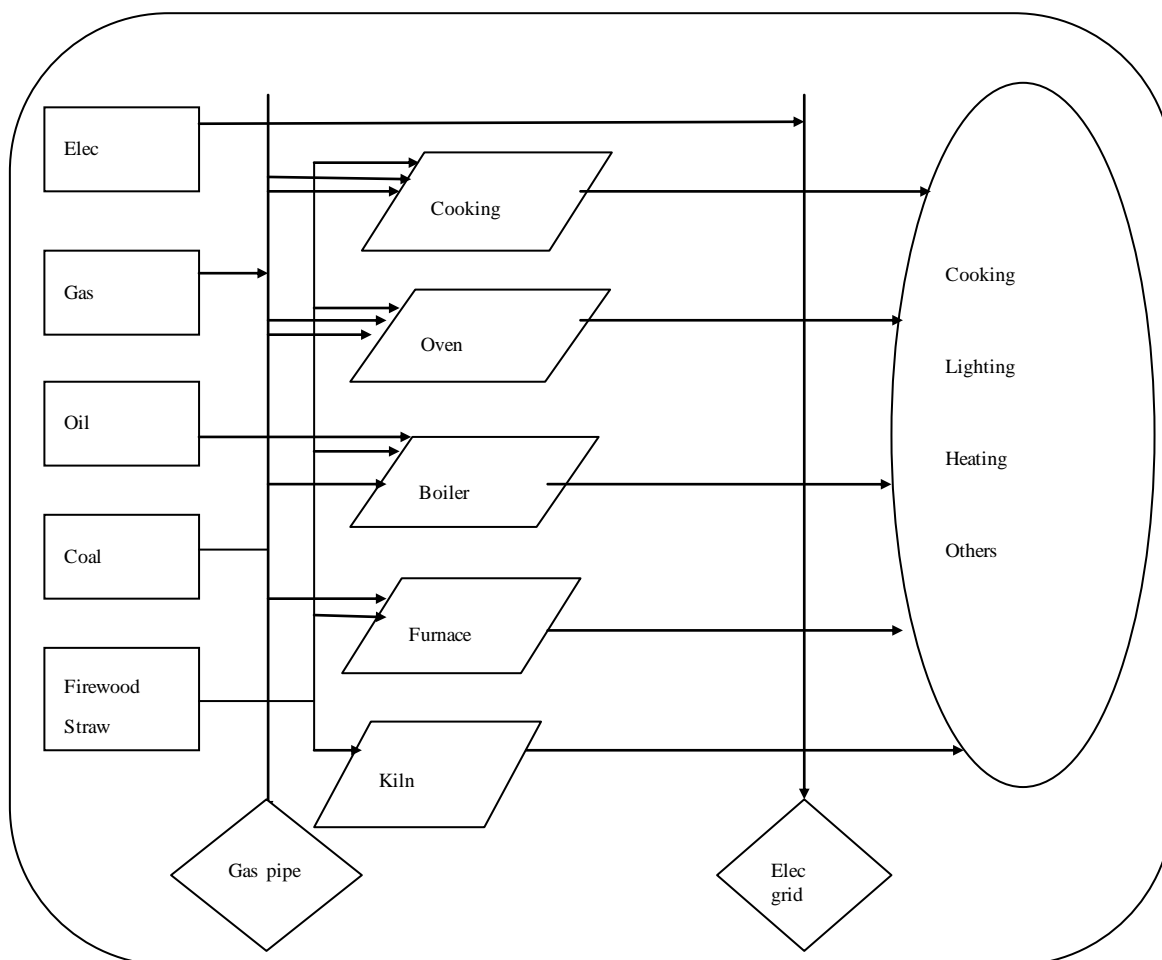

Figure 1.6 Reference Energy System of rural energy system

● RES of urban areas in China

The energy consumption in urban area is primary on commercial purpose rather than residential one. See from Figure 1.7, electricity, natural gas, oil and coal are the major energy sources used in urban areas which can provide energy service in industrial, residential, commercial and transport sectors. According to S.D [32], in 2006, the total urban energy consumption was around 1735.7 Mtce, of which commercial energy accounts for 81.32%. Increasing natural gas consumption for heating and cooking purpose of citizens in urban can reduce correspond GHG emission by replacing of coal to some extent. Additionally, emission from energy fuels consumption is not only related to energy sources but also to energy conversion efficiency.

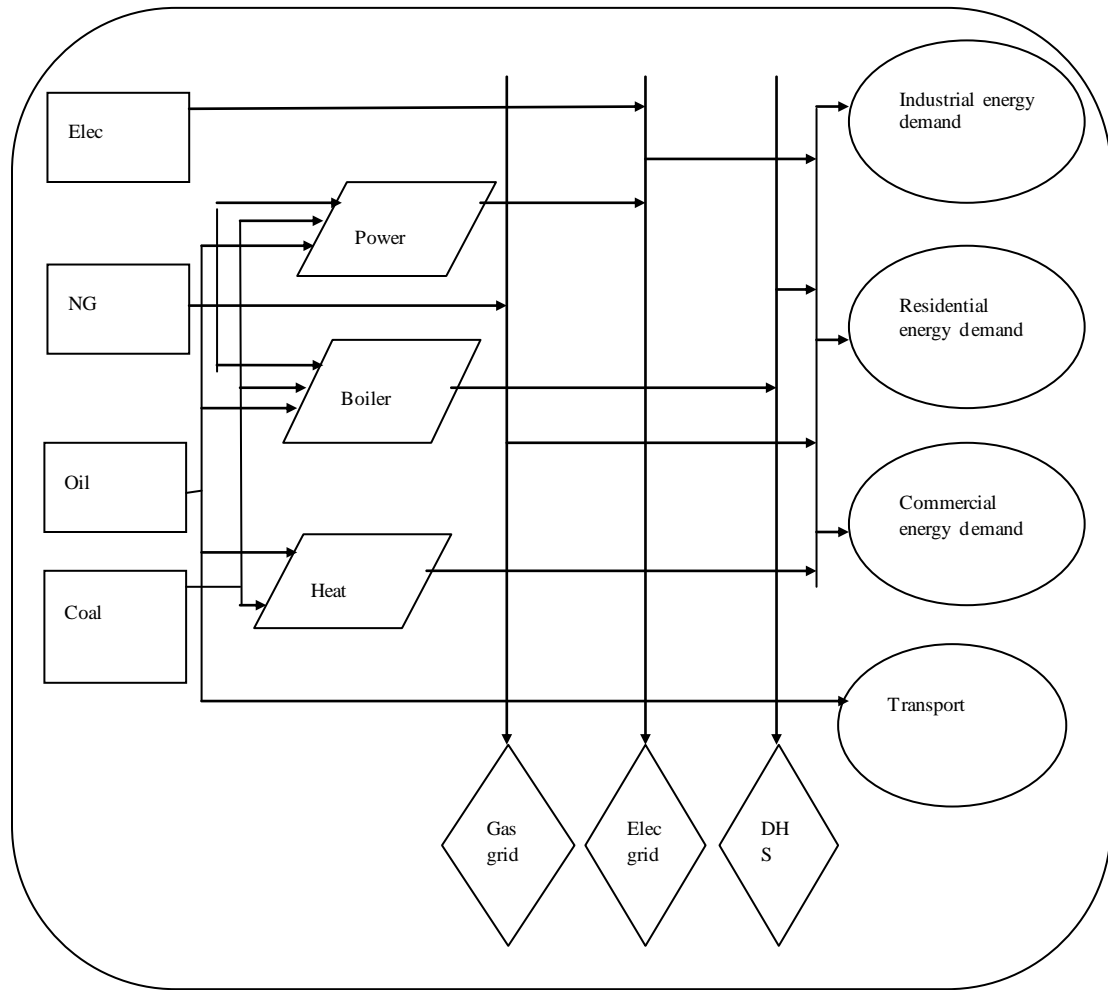

Figure 1.7 Reference Energy System of urban energy system

2. Methodology and data assumption

2.1 Methodology

There are two methodologies used for assessing environmental impact of ‘manure-biogas-digestate’ system substitution and drawing final conclusion.

- Calculate GHG emission abatement from ‘manure-biogas-digestate’ system substitution in rural household and M&L livestock farm in suburb respectively, which is mainly based on IPCC guideline.
- Assess the GHG emission abatement of biogas system development based on future estimation. Changes of future energy consumption pattern and agricultural land areas are two scenarios taken into account.

2.1.1 GHG emission abatement from ‘manure-biogas-digestate’ system

In order to simplify the calculation of GHG emission abatement from entire system, ‘manure-biogas-digestate’ system is divided into two parts, which are ‘manure-biogas’ system and ‘manure-digestate’ system. GHG emission abatement equals to GHG emission from reference system minus GHG emission from ‘manure-biogas-digestate’ system, these emission estimates are based on IPCC guideline. From 2006. GHG emission of ‘manure-biogas’ system is from biogas production and utilization phase and GHG emission of ‘manure-digestate’ system is from digestate applied on soil. *Appendix 2* shows the schematic view of both household biogas system and farm-based biogas system.

1. GHG emission abatement from ‘manure-biogas’ part

‘Manure-biogas-agriculture’ system can not only reduce the energy crisis of rural regions and over reliance on fossil fuels in urban, improve the ecological environment and sanitation condition and local economic development, but also reduce the greenhouse gas emission from fossil fuel combustion. Biogas has high heat value ($21\text{MJ}/\text{m}^3$) and thus can replace of fossil fuels, such as coal, and other biomass resources like straw and firewood to provide heat for rural residents. In rural regions, heating, cooking and lighting are the major ways to use the energy, hence CO_2 emission abatement by biogas system mainly relies on how much fossil fuels it will be replaced. (*Appendix 3*) In traditional manure treatment in China, methane always emits from uncovered and simple manure storage tank. Compared to this, anaerobic digester efficiently reduces methane emission from manure management (*Appendix 4*). As for biogas combusted for heat and electricity production, resulting GHG emission should be reported under energy sector based on *IPCC guideline-Volume5_Ch4_biological waste water treatment* [33]. However, CO_2 emission from biogas combustion is of biogenic origin which is regarded as 0, the N_2O as well as CH_4 emission from that need to be considered. When biogas is burned, the emissions are depended on quality of combustion facility. The combustion facility effects heat conversion efficiency to some extend which should be taken into consideration when assessing environmental impact of biogas utilization. As for biogas system of M&L livestock farm, manure treatments of both ‘energy-environmental’ biogas system and ‘energy-ecological’ biogas system are anaerobic digestion but with different types of

anaerobic digester. The comparison between these two systems is the main purpose of GHG emission abatement. The emissions produced from biogas production are different in energy utilization aspective and digestate treatment aspective. Therefore, GHG emission abatement by biogas system substitution is based on four parameters, ERES (emission reduction from energy substitution), ERMM (emission reduction from manure management), EBC (emission from biogas combustion) and EBP (emission from biogas production). GHG emission abatement from ‘manure-biogas’ system equals to $ERES+ERMM-EBC-EBP$. All the formulas and parameters used for calculation is gathered in *Appendix 6*.

- ERES (emission reduction from energy substitution)

The ERES is calculated as GHG emission produced from energy fuel combustion which is replaced by biogas. This parameter strongly depends on types of energy fuels consumed in reference system.

- a. In household biogas system, the reference system to be replaced is traditional household system. The common energy fuels used in rural area are coal, straw and firewood. Due to carbon neutral of straw, as a energy fuel, only coal and firewood⁷ are considered as the energy fuel to be replaced by biogas. The coal and firewood consumption is based on their share of entire rural energy consumption. (*Table 1.19*) and GHG emission from them are calculated as the formula (*Appendix 6*), $EF_{GHG\ fuel}$ are shown in *Appendix 7*. The GHG emission from coal and firewood combustion are regarded as ERES of household biogas system;
- b. In livestock farm-based biogas system, coal as the only energy fuel used in suburbs is considered. Biogas produced from ‘energy-environmental’ biogas system aims to providing heat for residents when burned in oven and biogas produced from ‘energy-ecological’ biogas system is used for electricity generation. Hence, the GHG emission abatement of ‘energy-environmental’ biogas system equals to $ERES_{GHG\ fuel1}$ of coal combustion for heat and that from latter system equals to $ERES_{GHG\ fuel2}$ of coal for electricity production. The $ERES_{GHG\ fuel}$ from ‘energy-ecological’ biogas system substitute of ‘energy-environmental’ biogas system is $ERES_{GHG\ fuel2}$ minus $ERES_{GHG\ fuel1}$.

- ERMM (emission reduction from manure management)

Methane and nitrous oxide are two major emissions from livestock manure management system depending on livestock categories, manure production and manure treatment. Both the formulas for CH_4 as well as N_2O emission and parameters for calculation are shown in *Appendix 6*.

- a. In rural areas, livestock manure is treated as slurry/liquid storage, uncovered lagoon, and composting. GHG emission from manure treatments are based on *IPCC guideline Volume4—manure management system* [21].
- b. In livestock farm-based biogas system, traditional livestock farm system use composting as the only manure treatment. Because it is seen as the reference system of both ‘energy-environmental’ biogas system and ‘energy-ecological’ biogas system, it leads to the same GHG emission when ingredients of feedstock

⁷ Firewood as a traditional biomass resource should be considered as carbon neutral in big map of CO_2 cycle. However, in rural areas of China, farmers used to cut down trees without further planting. The CO_2 emit from firewood combustion cannot be reduced by photosynthesis of new trees. Hence, firewood is included in environmental assessment of this thesis.

keeping stable. The ERMM of ‘energy-environmental’ biogas system substituted by ‘energy-ecological’ biogas system is only calculated as GHG emission from MMS of former system minus MMS of latter one. The feedstock disposed during biogas production process is seen as the manure management system rather than biological waste or wastewater treatment because the manure treated here is seen as the only ingredient with the water which flush manure to treatment system on livestock farm. Hence, GHG emission from biogas production process, including AD, solid composting, slurry storage and aerobic treatment are all based on *IPCC guideline Volume4- manure management system* [21];

- EBC (emission from biogas utilization)

The calculation of EBC is similar as ERES. (*Appendix 6*)

- a. In household biogas system, GHG emission is from biogas combustion, which should consider the biogas combustion efficiency in calculation;
 - b. Biogas produced from anaerobic digestion in ‘energy-ecological’ biogas system is used for generating electricity which will transport to residents for daily consumption. The emission from CHP is calculated here; GHG emission from biogas combustion directly is for ‘energy-environmental’ biogas system.
- EBP (Emission from biogas production)

Emission from biogas production equals to that from anaerobic digestion process. This can be seen as the emission produced from AD⁸ manure management system and that from energy consumption when producing biogas.

- a. In household biogas system, no external heat supply is taken into consideration and anaerobic digester operates nearly 3/4 of a year. The EBP produced is only from anaerobic digester when storing livestock manure.
- b. In livestock farm biogas system, heat is generated by coal burned in boiler which is equivalent to 1/3 of energy contained in biogas production and electricity bought from national electricity grid which should be taken into account. All these energy consumption which are produced by fossil fuels produce GHG emission especially CO₂ emission to atmosphere. In addition, as for AD manure treatment, N₂O and CH₄ are produced when manure stored. The leakage from manure storage and leakage is not considered due to inefficient data of AD selected. The formula for emission calculation from manure management is the same as that for ERMM; (*Appendix 6*)

2. GHG emission abatement from ‘manure-digestate’ system

In agricultural sector, N₂O is an important greenhouse gas and agricultural soil is a major source of nitrous oxide emission. N₂O is produced naturally in soil through nitrification and denitrification. Nitrification is the aerobic microbial oxidation of ammonium to nitrate (NH₄⁺→NO₃⁻) and denitrification is the anaerobic microbial reduction of nitrate to nitrogen gas N₂ (NO₃⁻→N₂). N₂O is produced in the reaction sequence of denitrification and a by-product of nitrification. The N₂O emission results from anthropogenic N input and N mineralization occur through both a direct and indirect pathway [34].

- Direct pathway: N₂O emission is directly from soils to which N is added;

⁸ AD is short for anaerobic digester

- Indirect pathway: Volatilization of NH_3 and NO_x from managed soil; after leaching and runoff of N from managed soils, mainly as NO_3^- ; fossil fuel combustion and biomass burning: the subsequent redeposition of NH_3 and NO_x and their products NH_4^+ and NO_3^- to soil and water.

Appendix 5 represents sources and pathway of N_2O emission in soil management system. Since this study mainly focuses on GHG emission reduction in ‘manure-biogas-agriculture’ system, the nitrous oxides emission reduced by livestock manure available to soil replacing of industrial fertilizer is analyzed in the first place. The green colour boxes in *Appendix 4* shows the relation between livestock manure management and soil management as well as nitrous oxides emission from both system. *Appendix 6* shows all the formula and parameters for GHG emission calculation from ‘manure-digestate’ parts of both household biogas system and M&L livestock farm-based biogas system.

- GHG emission abatement from substitution of synthetic ammonia

The GHG emission abatement from ‘manure-digestate’ part mainly considers how much emissions are reduced by digestate applied on arable land. Synthetic ammonia is the industrial fertilizer commonly used in China and it is the objective to be replaced by digestate in two biogas systems. The GHG emission abatement from fertilizer substitution includes two aspects. One is the emission from fertilizer production. In China, coal is used as the major energy fuel for industrial fertilizer production. 2.2 Mt coals are used for producing 1 Mt of N fertilizer, which means 2200 kg coal for 1 ton of synthetic ammonia production [35]. And emission from coal combustion is seen as the only GHG emission from fertilizer production phase [36]. The formula used for emission calculation is as the same as that for ERES. The combustion efficiency of coal is 40% should be included. What’s more, the amount of synthetic ammonia equals to NH_4^+ content in digestate which is assumed as 60% of total N content [37]. The second GHG emission is produced when synthetic ammonia used on soil (See *Figure 2.1*). Applying synthetic N-fertiliser means not only N_2O emissions from soil but also CO_2 is also loss during synthetic ammonia fertilisation. Synthetic ammonia ($\text{CO}(\text{NH}_2)_2$) is converted into NH_4^+ , OH^- and HCO_3^- in the presence of water and urease enzymes. HCO_3^- that formed evolves into CO_2 and water.[38] Hence, based on *IPCC guideline volume 4*, CO_2 is suggested to consider when it applied on soil.

- In household biogas system, the GHG emission abatement in ‘manure-digestate’ part results from GHG emission from synthetic ammonia production and utilization, which contained as the same amount of NH_4^+ as digestate, minus GHG emission from digestate applied on arable land;
 - In livestock farm-based biogas system, the GHG emission in present situation is assumed to come from all synthetic ammonia fertilizer and use on farm. This is equal to GHG emissions from ‘energy-environmental’ biogas system since all digestate produced from this system aren’t used for fertilizer purpose. Hence, the GHG emission abatement from ‘energy-ecological’ biogas system substitutes of ‘energy-environmental’ biogas system is only the GHG emission abatement from former system itself. What’s more, sell of manure in market after composting is not taken into consideration in this part.
- GHG emission produced by digestate applied on soil

Before calculating the GHG emission from ‘manure-agriculture’ system, the nitrogen flow in this system should be identified because N_2O is the dominant emission in agricultural sector which is tightly correspond with N flow (See *Figure 2.1*). Based on IPCC methodology of calculate nitrous oxides emission from soils, large percentage of emission is mainly caused by industrial fertilizer and organic fertilizer. Therefore, the nitrous oxides emissions from industrial fertilizer replaced by manure application can be seen as an effective solution of emission abatement in agricultural sector. Total nitrogen in digestate should be seen as N content left after anaerobic digestion. From *Figure 2.1*, N applied on soil equals to total N content in feedstock minus N lost during manure treatment. The livestock manure is assumed to be purred into anaerobic digester immediately, so the N loss 1 is neglected here.

- In household biogas system, digestate is stored in anaerobic digester which is removed twice a year. N content in digestate applied on soil is decided by ingredients of feedstock and N lost during the storage. N lost is calculated as N_2O lost during a year.
- In livestock farm-based biogas system, effluent from anaerobic digester in ‘energy-environmental’ system is treated as sewage without any agricultural utilization. Hence, this part is considered as 0. While in ‘energy-ecological’ system, digestate replacing synthetic ammonia are used on soil.

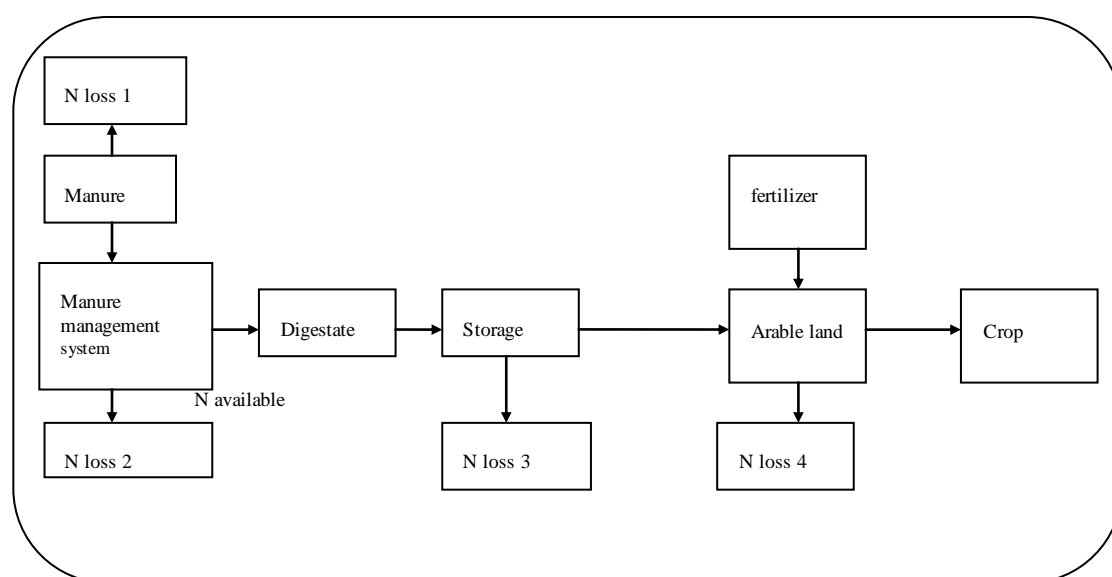

Figure 2.1 N flow from livestock collection to organic fertilizer utilization

2.1.2 Future estimation of GHG emission abatement of ‘manure-biogas-digestate’ system development

The GHG emission abatement from household biogas system is calculated from energy and manure management aspects included in ‘manure-biogas’ parts and agricultural aspects included in ‘manure-digestate’ parts. However, with the change of traditional energy consumed and arable land areas irrigated in reference system, GHG emission abatement from biogas system is variable. Hence, future estimation is done here in order to assess which factor will take more effect to GHG emission abatement. Since the purpose of household biogas system and livestock farm-based biogas system are different, future estimation is also applied for judging whether main purpose of

these two systems is appropriate for environment improvement. What's more, it aims to looking for constraint conditions for further development of biogas system.

1. Household biogas system

Household biogas system is encouraged to implement in rural area results from its energy purpose. However, when analysing the entire 'manure-biogas-digestate' system, both the energy and agricultural perspective are considered. Hence, whether it is appropriate to develop the household biogas system should also make environmental analysis to digestate utilization as well. The future estimation of household biogas system is focused on two parts:

- To assess the GHG emission abatement from household biogas system through increasing share of coal consumption in rural energy system. As described in Chapter 1, coal domestic consumption will increase 3-5% during 2006-2010 per year and 1-2% in the next 10 years annually. [27] Hence, the growth rate of coal consumption in rural areas is assumed the same as the domestic trend, and the sensitivity analysis of energy substitution is based on the coal consumption increased with same rate of firewood reduced. The aim is to estimate how environmental impact the biogas utilization will bring when RES changed in the future. This can make conclusion and suggestion to future development of household biogas system.
- To assess the GHG emission abatement from household biogas system through changing share of digestate applied based on arable land area. The future estimation is calculated as arable land area per household decreased by 4% and 16% which is according to the estimate of increasing crop yield per arable land from 2010-2030 related to urbanization. The aim of it is to emphasize the importance of concerning digestate utilization from agricultural perspective. In additional, the constraint condition of how much digestate will apply based on arable land area results from N-fertilizer consumption per hectare, which is suggested as 150-180kg/ha. Because the more digestate surpass the required N-fertilizer input, the more N will leach and runoff from soil, which leads to pollution to underground water. Hence, the GHG emission abatement from agricultural perspective should be under the condition of minimum water and soil pollution.

2. Livestock farm-based biogas system

Due to the reference system (traditional livestock farm) of both 'energy-environmental' biogas system and 'energy-ecological' biogas system are the same; hence, the GHG emission abatement is seen as the comparison between these two systems. Because livestock farm-based biogas system is applied only for environmental purpose, the aim of future estimation aims to pointing out how large effect from energy substitution part effect the total GHG emission abatement of biogas system development and what are constraint conditions when judging whether 'energy-ecological' biogas system is right for replacing 'energy-environmental' biogas system. Two variable factors are considered here.

- The first one is the increase of natural gas consumption in suburb nearby. In Chapter 1, introduction of RES of urban illustrates that the natural gas consumption will rise by 11-13% annually during next 15 years.[27] However, due to power generation plants are still run by coal, only heat production is substituted by natural gas in RES when estimate the future scenario. The results

from this future estimation will reflect how variable the GHG emission abatement when natural gas increased and coal decreased the same rate;

- The other factor is the change of arable land area based on TN and COD content in digestate under national irrigation standard (See *Table 2.1*) requirement. Only ‘energy-ecological’ biogas system is considered here because of digestate utilization. The maximum arable land area required is calculated by TN and COD content in digestate in case study. And the minimum arable land area is based on TN and COD content in digestate after SBR (aerobic treatment). The future estimation in ‘manure-digestate’ part illustrates how GHG emission abatement changed based on max and min required arable land area.

Table 2.1 National irrigation standard on farm [39]

Arable land	Rice	Wheat and maize	Vegetable
Irrigation water quantity L/mu ¹ .yr	800,000	300,000	200,000-500,000
COD mg/L	<=200	<=300	<=150
TN mg/L	<=12	<=30	<=30

*1. 1 mu=0.067 hectare

2.2 Data collection and assumption

2.2.1 Data collection

In order to get to know the present situation of biogas system development in rural household and M&L livestock farm in China, the fieldwork is indispensable. It is not only important for data collection but also for future suggestion based on investigation to different roles involving in biogas system. The *Biogas Scientific Research Institute of the Chinese Ministry of Agriculture* situated in Chengdu, Sichuan province offered the most support to my fieldwork. And the reflection to future development of two types biogas systems were mainly obtained from *2010 bio-energy expo* and *international bio-energy summit* in Beijing.

2.2.2 Data assumption

The environmental impact from biogas system mainly relies on ingredients of feedstock to anaerobic digester, types of anaerobic digester and types of biogas system. Hence, the data used for GHG emission abatement calculation of specific biogas project are all collected in fieldwork while to large-scale biogas system development should consider the other variable factors.

1. Household biogas system

- Fixed factor assumption of household system in case study

The GHG emission abatement and sensitivity analysis of household biogas system in rural area in this thesis is based on the result of fieldwork rather than the large-scale system analysis. Hence, the factors below are fixed if analysis is done in the same

area. However, if large-scale analysis is estimated, most of factors should be changed according to local situation, which are included in variable factor assumption to be mentioned in conclusion part for future development suggestion.

a. Energy demand per person

This data is obtained from the investigation on research field, which is 0.3 m³ biogas per people per day. And total energy demand of household can be simply calculated as the result of unit energy demand multiplies the people of family.

b. Biogas yield from livestock manure

It is affected by amount of livestock manure and the other substrate added. Because the raw materials are mixed, the biogas yield is hard to estimate only depending on the types of substrate in biogas digester. In order to get the max biogas yield, ratio of manure and straw is suggested as 5/1 by scientists in China. Hence, biogas yield should also be assumed as fixed factor if amount of livestock manure is known.

c. Energy efficiency of traditional energy fuel

In household biogas system, coal and firewood are two energy fuel to be substituted by biogas, of which the energy efficiency for heat are 40% and 24%. What's more, biogas is normally considered as the renewable energy, from which CO₂ emission is 0, but with shrink of arable land area, the capacity of CO₂ emission recovery is decreased. Hence, CO₂ emission from biogas combustion should be considered here. The energy efficiency from biogas to heat is 60% in household biogas system.

d. Types of industrial fertilizer applied on arable land

Synthetic ammonia is assumed as the only industrial fertilizer applied on arable land and to be substituted by digestate. The NH₄⁺ contained in digestate is 60% of total N and it equals to the same amount of synthetic ammonia consumption.

e. Fraction of manure management system

When concerning the manure management system in calculating GHG emission abatement from system, fraction of each manure management system is assumed as 1.

The agricultural plants in arable land close to household digester

The agricultural plants cannot be changed when making sensitivity analysis.

f. Arable land area

Each household has the fixed size of arable land. 1 mu=0.067 hectare per household in rural area.

● Variable factor assumption of household system in large-scale estimate

Allocation of coal and firewood consumption in rural energy system and share of digestate applied on arable land are two variable factors are considered in future estimation. The following variable factors are not included in calculation but to be mentioned in conclusion part in *Chapter 3* for future development suggestion.

a. Types of household biogas system

'4 in 1' and '5 in 1' household biogas system (*see explanation in Page 11 and 12*) common used in other parts of Chinese rural areas except western part lead to different GHG emission abatement by biogas system implement.

b. Ingredients of feedstock to anaerobic digester

Dairy cows, cattle and chicken breed in rural area is not considered in the case study. However, due to different TS, VS and N content in their manure, the biogas yield and organic fertilizer benefits are various.

c. Types of plants grown in agricultural land per household

The parameters shown in *Table 2.2* reflect the amount of digestate applied on soil is required by types of plants. The climate is different according to geographical distribution in China, crops and other plants are various.

2. Livestock farm-based biogas system

Different from household biogas system, livestock farm-based biogas system is more complex according to anaerobic digester selection and biogas production process design. Two biogas systems are discussed in this thesis, and dairy cow manure is the only manure in feedstock for biogas production. The certain type of anaerobic digester has been chosen by project design of each system.

- Fixed factor assumption of livestock farm-based biogas system in case study

a. Biogas yield from livestock farm

This data can be obtained based on amount of livestock and manure production per livestock on farm. In this case study, the substrates are mixed with manure, urine and wastewater from farm, of which the biogas yield is calculated according to full-scale data.

b. Energy consumption of residents surrounding

The energy consumption of residents living beside livestock farm is assumed only produced by coal combustion. The coal combustion efficiency is 40% and the combustion efficiency of natural gas is 57% in sensitivity analysis. In addition, biogas produced from 'energy-ecological' biogas system is for electricity generation. The electricity conversion efficiency is 36% and heat conversion efficiency is 45% from CHP.

c. Energy consumption on farm

On livestock farm, the energy consumption is concerned as heat and electricity demand for all facilities in biogas production process. Because 'energy-environmental' biogas system and 'energy-ecological' biogas system are two systems adopted for the same project, of which the heat and electricity is considered as equal. and when making comparison, the GHG emission from this part is 0, which can be neglected.

d. Chemicals contained in discharged water

The chemicals contained in effluent from anaerobic digester are based on the types of digester chosen by biogas system and feedstock formation. In order to get the national discharged wastewater standard, aerobic pond is designed in the process. In this case study, the removal ratio of TN and COD in slurry is assumed as 74.1% and 52.7-82.1% based on SBR technology [40].

- Variable factor assumption of livestock farm-based system in large-scale estimate

Number of dairy cow breed on farm and crops on agricultural land are two variable factors concerned in future estimation in case study. However, to large-scale livestock farm-based biogas system development in China, the following factors should also be discussed.

a. Types of livestock breed on farm

In China, 4700 M&L livestock farm will implement biogas system at end of 2010 (*Chapter 1*). Chicken, cattle and pig farm are all included. Various types of livestock manure result in different biogas yield and chemical content in digestate as well as the entire biogas production process design.

b. Types of crops on arable land

N content in digestate for agricultural purpose should be considered as constraint condition for biogas system implement due to N fertilizer consumption requirement and types of plants irrigated. Through investigation of 1333 farms in 11 provinces in China from 2001 to 2005 [12], the results have implied that the biggest crop yield (t/ha) is achieved when N fertilizer input is in the range 150-180 kg/ha, however, the N efficiency is less than 30%. And if N efficiency is increased up to 50%, the yield of crops will fall down. Hence, to control consumption of N fertilizer in an appropriate range cannot only improve crop yield but also reduce N loss to environment.

Table 2.2 N fertilizer rate, grain yield and RE_N^9 of rice, wheat and maize [25]

	Rice		Wheat		Maize	
N rate Kg/ha	RE_N %	Yield (t/ha)	RE_N %	Yield (t/ha)	RE_N %	Yield (t/ha)
<60	49	6.2	55.4	5.8	40.2	6.2
60-120	37.3	6.5	40.3	5.5	31.2	6.6
120-180	27.4	6.8	33.2	5.7	29.8	7.1
180-240	23	7.1	22.4	6.2	24.1	8.2
>240	15	6.9	11.3	5.7	14.4	5.5

Observe from Table 2.2, the N fertilizer rates to these three grains are all in the range of 180-240 kg/ha when the highest yield is achieved, but with the lowest recovery efficiency of N fertilizer. Conversely, if the highest recovery efficiency of N fertilizer is expected, the yield of grains cannot get the highest. During another investigation of N fertilizer consumption of 20,000 farmers between 2000 and 2002 around China, the average N rate is 215 kg/ha for rice, 187 kg/ha for wheat and 209 kg/ha for maize,

⁹ RE_N (apparent recovery efficiency of applied N) = $(U-U_0)/F$

- U =N captured by crop when it is harvest from arable land with fertilizer input;
- U_0 = N captured by crop when it is harvest from arable land without fertilizer input;
- F =amount of fertilizer input;

which are all concentrate on crop yield more than recovery efficiency. Hence, large amount of N lost to environment in agricultural sector. In China, the recommended N rate to crops are in range of 150-200 kg/ha and 250 kg/ha is the maximum.

c. Types of anaerobic digester

The anaerobic digester plays an important role in biogas production and chemicals removal in process. Based on the purpose of biogas system implemented on livestock farm, different anaerobic digester is chosen. The factors used for AD selection are VS concentration of feedstock, required biogas yield, required chemical content in slurry and energy demand for biogas production.

3. Case study

Two case studies in this chapter is selected as an example to represent biogas development in rural area and livestock farm in China. Each case study contains two scenarios, one is based on reference system and the other is based on suggested system. Due to different backgrounds of two case studies, the selection of reference system and suggested system in each should be connected with local situation.

- Case study 1 is done in rural areas in Sichuan province, in which the household biogas system is built for replacing of traditional household system. Hence, in case study 1, the reference system is chosen as traditional household system and suggested system is household biogas system.
- Case study 2 reflects the biogas project on dairy cow farm in Inner Mongolia. The reference system is ‘energy-environmental’ biogas system and the suggested system named ‘energy-ecological’ biogas system.

The purpose of this chapter aims to introducing the background of each case study and calculating GHG emissions of two scenarios in each case study. This Chapter provides the basic data for assessing GHG emission abatement of each case study in Chapter 4, which is the foundation for justifying whether suggested system is appropriate to substitute of reference system. The background information and basic data of both case studies including livestock amount, family size, arable land areas as well as facility capacity were obtained from fieldwork.

3.1 Case study 1—household biogas system

3.1.1 Background of case study 1



Figure 3.1 Map of Sichuan province

Western China is chosen as a research region of household biogas system because of its natural and social environment. Land areas of western China occupy 72% of total areas in China but the population density is only 0.55 per hectare. In energy

perspective, most of remote areas and under developed areas are in this region, where the main energy carriers of people's daily life are firewood and straw. If biogas project developed universally in these areas, it is a good solution to energy crisis of people there. From agricultural perspective, distribution of arable land in this region is imbalance. Most of arable land with higher productivity concentrates in Sichuan basin but other areas especially in northwest are facing with severely soil erosion and desertification. Hence, with such a great potential to develop the household biogas project, Sichuan province is selected as the fieldwork site for household biogas system research. The map of Sichuan is shown as *Figure 3.1*, of which the average temperature ranges between 14°C-19°C per year. The average temperature in spring is between 10°C-21.9°C which lasts for three month; The average temperature of summer is more than 22°C; The temperature in autumn is similar with that in spring and 3-8°C is the average temperature in winter. [41]

3.1.2 GHG emission calculation of case study 1

1. Basic information about case study 1

In western part of rural China, swine is the most common livestock breed in household, the manure of which is chosen as a research feedstock of household biogas project. The household system selected for environmental analysis contains 3 people and 4 pigs breed in the backyard. The types of pigs are all fattening pigs which are breed for 4 months each time and 12 swine totally in one year. The functional unit for calculation is set as the total weight of swine manure for biogas production per household.(See *Table 3.1*) The arable land area per functional unit in scenario 1 is 1 mu which is equivalent to 1/15 hectare. Because the temperature in winter is not appropriate for biogas production, 3/4 of one year is considered in calculation.

During the fieldwork of household biogas project in rural areas of Chengdu, the swine manure, human manure and straw are common components of feedstock for biogas production by anaerobic digestion in household digester. Because the aim of this research mainly focuses on GHG emission abatement of biogas production from livestock manure, the human manure and straw added are not taken into consideration in the case study 1. The biogas in rural areas from household biogas digester is used for lighting, heating water and cooking. The total biogas output is based on biogas combustion efficiency. Total energy content in biogas utilization per functional unit is shown in *Table 3.2*.

Table 3.1 Total swine manure to biogas digester per household per year, this figure is set as the functional unit. (kg)

Feedstock	Unit weight (kg/hd.day)	Number of swine (head)	Life time of swine (day)	Total swine manure to biogas digester (kg)
Swine manure	2	12	91	2190

Table 3.2 Total energy content of biogas utilization. This figure is based on the functional unit (MJ)

Total swine manure (kg)	TS (%)	Biogas producing rate (m ³ /kg TS)	Biogas yield (m ³)	Energy content of biogas (MJ)	End-use (MJ)
2190	18.5	0.375	152	3192	1723

* 1 m³ biogas=21MJ ; Biogas combustion efficiency is 60% and leakage of biogas from household AD is 10% of biogas yield.

Besides biogas produced from household biogas digester, the by-product of digester is the digestate with large amount of nutrients, such as N and P content. However, the data of N and P content in human manure and straw are hard to get, the N and P content of digestate only takes that of swine's manure into account. (See Table 3.3)

Table 3.3 N and P content of swine manure for biogas production per household per year. This figure is calculated based on functional unit. (Kg)

N content of swine manure (kg/head)	P content of swine manure (kg/head)	Number of swine (head)	N content of swine manure ¹ (kg)	P content of swine manure ¹ (kg)
3.7	0.8	12	33.3	7.2

*1. The manure used for biogas production depends on operational time of anaerobic digester, which is 3/4 of one year.

2. GHG emission from scenario 1 in case study 1

See the Figure 3.2, the traditional household system (Scenario 1) is chosen as the reference system to household biogas system in case study 1. It is divided into three parts for its environmental analysis. The GHG emission from its energy perspective results from energy consumption pattern in this system; The GHG emission from its manure management system depends on different manure storage method; The GHG emission from agricultural perspective is mainly relied on energy used for making industrial fertilizer which applied on arable land.

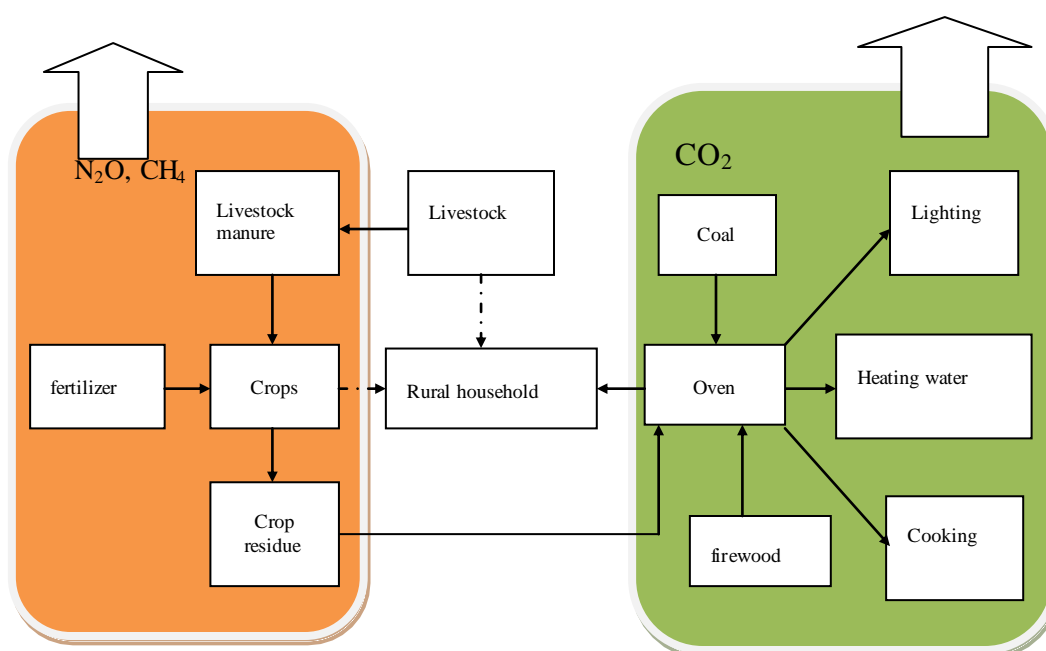

Figure 3.2 Traditional household system

GHG emission from energy perspective of scenario 1

In rural areas of China, coal, straw and firewood are used as the main energy fuel for people's daily life. Based on Table 1.19 in Chapter 1, allocation of these three energy fuels consumption in rural areas of China in 2005 occupied almost 86% of total energy consumption, in which firewood is 24% and coal is 32%, which is seen as 57% and 43% when substituted by biogas. The amount of these two energy fuel is calculated based on equivalent energy content of biogas produced from household biogas digester per year. The result of this calculation can be seen as GHG emission abatement replaced by biogas, which is presented as $ERES_{GHG\ fuel}$ (emission reduction from energy substitution) for short. (See Table 3.4) The GHG emission factor of coal and firewood are shown in Appendix 7.

Table 3.4 Energy input (MJ) of coal and firewood amount to equivalent biogas utilization and emissions (kg) from combustion.

Energy fuel consumption in reference system	Biogas energy equivalent (MJ)	Energy input (MJ)		GHG emission (kg)			
		Share %	Heat	CO ₂	CH ₄	N ₂ O	CO ₂ -equ ¹⁰
Coal	1723	57	982.5	232.3	0.024	0.004	234
Firewood		43	741	345.7	0.1	0.013	351.5
Total GHG emission from energy perspective (kg)		100	1915.2	578	0.124	0.017	585.4

*The energy here only points out daily life energy demand, such as lighting, space heating and cooking. Coal=29MJ/kg; Firewood=16.6MJ/kg. The amounts of fossil fuel are calculated according to their share in rural energy consumption system and combustion efficiency. Combustion efficiency of coal is 40% and firewood is 24%.

$ERES_{GHG\ fuel}$ (emission reduction from energy substitution) equals to total GHG emission produced by coal and firewood consumption in rural household. Based on Table 3.4, it is clear to see that the GHG emission from coal is less than firewood although it has higher allocation in energy system. 40% of total CO₂-equ emission is produced from coal and 60% is from firewood.

GHG emission from manure management perspective of scenario 1

In rural areas of China, there are three types of manure management system commonly used by farmers. The total manure from pigs per functional unit is 2190 kg. The GHG emission from manure management system in traditional household system is calculated upon types of manure treatment used by farmers. The result of this calculation is named ERMM (emission reduction from manure management) for

¹⁰ 1 t CH₄ = 21 t CO₂-equivalent, 1 t N₂O = 310 t CO₂-equivalent

short, which are shown in the *Table 3.5* below. The formula used for calculation is introduced in Chapter 2 based on IPCC guideline-Volume 4 and shown in *Appendix 7*.

Through the comparison among these four MMS¹¹, it is clear to see that the CO₂-equ emission from composting is the least which is nearly 1/4 of that from slurry and uncovered lagoon system. The N₂O emission per functional unit from composting is the largest but the CH₄ from this manure management system is the least.

Table 3.5 GHG emission from traditional MMS and digestate utilization, this figure is based on functional unit (kg)

MMS	Swine manure input (kg)		GHG emission (kg)		
	VS ¹	TN	CH ₄	N ₂ O	CO ₂ -equ
Composting	340	33.3	0.66	0.84	274.1
Uncovered lagoon			52.23	0.32	1196
Slurry/liquid			43	0.58	1082.2

*1. VS is calculated based on functional unit which is total VS of swine manure per year. 2. The average temperature of scenario 1 is assumed as 25°C, on which MCF value of different MMS is based.

GHG emission from agricultural perspective of scenario 1

In agricultural perspective of traditional household system, the GHG emission is calculated based on energy consumption used for making synthetic ammonia which are the most common N-fertilizer applied on arable land per household. Based on *Table 1.15*, N fertilizer consumption in 2007 in China is 230 kg N/ha which is equal to 15.3 kg N/mu (1 mu=0.067 hectare). However, according to N content in swine manure in *Table 3.4*, 33.3 kg N contained in digestate per function unit can produce 60%-70% of NH₄⁺ by microorganism in soil. It can substitute of all the N-fertilizer applied per mu arable land. According to The norm of energy consumption per unit product of synthetic ammonia made by Chinese government, the coal consumption per ton of synthetic ammonia mustn't be more than 2200 kg.[35] *Table 3.6* shows the GHG emission from coal combustion for making synthetic ammonia, and N₂O and CO₂ emission from soil where synthetic ammonia applied.

Table 3.6 GHG emissions from synthetic ammonia production and utilization, the total GHG emission from agricultural perspective is based on functional unit (kg)

Synthetic	TN-equ	NH ₄ ⁺ /TN	Synthetic	Coal for	GHG emission (kg)
-----------	--------	----------------------------------	-----------	----------	-------------------

¹¹MMS is short for manure management system

ammonia (NH ₄ ⁺) input	in swine manure (kg)	in swine manure (%)	ammonia substitution (kg)	ammonia production (kg)	CO ₂	CH ₄	N ₂ O	CO ₂ -equ
Production	33.3	60	19.98	44	120.7	0.013	0.002	122
Utilization					7.3		0.16	57
Total GHG emission from agricultural perspective (kg)					128	0.013	0.162	179

When the same amount of synthetic ammonia applied on soil, the direct N₂O and indirect N₂O are the main GHG emission from soil. The GHG emission is calculated based on IPCC guideline and formula is stated in Chapter 2. The manure treated from traditional manure management system is also used as fertilizer on soil but it doesn't replace of the industrial fertilizer per household, farmers are used to selling this organic fertilizer in the market. The emissions from this part are not to be calculated in this system. In additional, based on IPCC guideline, the CO₂ emission from urea is included in GHG emission from urea applied on soil. According to chemical reaction from urea to ammonium in soil, 1 urea can be degradable into 2 ammonium.

3. GHG emission from scenario 2 in case study 1

Figure 3.3 represents household biogas system which is encouraged to replace of traditional household system in rural areas of China. This system is the suggested system for future development in rural China and it is the scenario 2 in case study 1. Compared to reference system, GHG emission from biogas system includes biogas combustion from energy perspective, manure storage in AD and digestate (organic fertilizer) applied on soil.

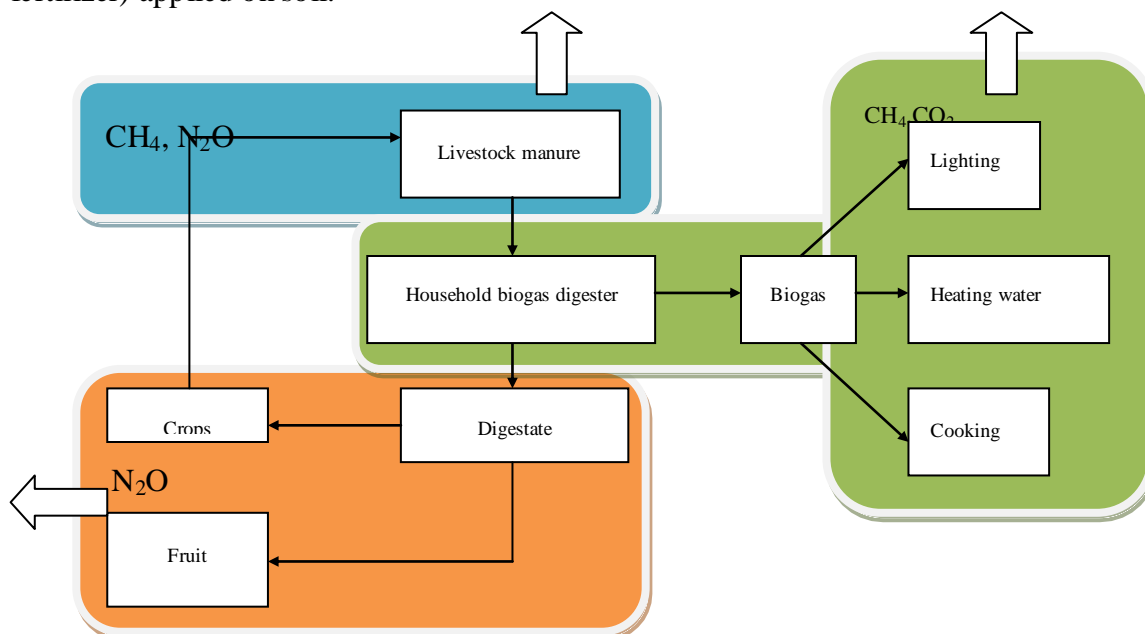

Figure 3.3 Rural household biogas system

GHG emission from energy perspective of scenario 2

The biogas produced from household anaerobic digester is used for heating purpose for people's daily life. Due to CO₂ emission from biogas combustion is of biogenic

origin, the GHG emission only includes N₂O and CH₄. The result is illustrated in Table 3.7.

Table 3.7 GHG emission from biogas combustion. Data is based on functional unit. (kg)

Household biogas system	Energy input (MJ)	GHG emission (kg)			
	Biogas combustion	CO ₂	CH ₄	N ₂ O	CO ₂ -equ
	2872	0	0.003	0.0003	0.15

GHG emission from manure management perspective of scenario 2

Anaerobic digester as one of the manure management systems also emits GHG emissions when producing biogas. The GHG emission from AD stated in Chapter 2 is only focused on treatment of livestock manure. The emission factor of human manure and straw are not introduced here. Hence, the result of this calculation shown in Table 3.8 is only based on anaerobic digestion of swine manure. After manure is treated in AD, it would store in uncovered lagoon. The GHG emission from it should be considered. However, the emission from this part is extremely larger than the others because of large amount of methane emitted from uncovered lagoon.

Table 3.8 GHG emission from anaerobic digester in household biogas system, this figure is based on functional unit (kg)

MMS	Swine manure input (kg)		GHG emission (kg)		
	Biogas leakage	CH ₄ content	CH ₄	N ₂ O	CO ₂ -equ
AD	15.2	60%	6.11	0	128.3
Total CO ₂ -equ emission from MMS in household biogas system					128.3

*1. VS is calculated based on functional unit which is total VS of swine manure per year. 2. The average temperature of scenario 1 is assumed as 25°C, on which the density of CH₄ is 0.67kg/m³ and weight of CH₄ leakage is 152m³*0.6*0.1*0.67kg/m³=10kg. The CH₄ content of biogas is 0.6

GHG emission from agricultural perspective of scenario 2

After fermentation of anaerobic digester, digestate can be applied on soil as a kind of organic fertilizer. Assume the N quantity The total N content in swine manure is 33.3 kg per functional unit and each household has 1 mu (1/15 hectare) of arable land in this case study. The N content in feedstock input should be considered as the sum of N₂O and NH₃ emission and NH₄⁺ and NO₃⁻ left in digestate, but due to lack of data offered, the organic N-fertilizer input per mu arable land is assumed the same as the same amount of N content in swine manure, 33.3 kg. The CO₂-equ emission from

organic fertilizer applied on soil is shown in *Table 3.9* which is calculated as IPCC guideline in Chapter 2.

Table 3.9 GHG emission from organic fertilizer applied on soil and this figure is based on functional unit. (kg)

Household biogas system	Digestate input (kg)	GHG emission (kg)	
	TN in swine manure	N ₂ O	CO ₂ -equ
	33.3	0.32	67

3.2 Case study 2—Livestock farm-based biogas system

3.2.1 Background of case study 2

Because of high population density in eastern China, large demand of animal food product leads to increasing number of intensive livestock farms. From analysis above, livestock farm in eastern China will have the largest potential of biogas development in 2010. What's more, based on article written from Q.Z [26], the highest nitrous oxide emission from unit arable land is from this region, where is the largest fertilizer consumption per hectare input as well. Moreover, under transition of Chinese livestock husbandry system and urbanization process in future, intensive livestock farm will replace of household livestock husbandry pattern in China which will result in producing livestock manure more concentrate. Compared to household livestock husbandry pattern, intensive pattern has stricter requirement on surrounding capacity to sustain digestate in large amount. The eastern region of China is located along sea coast and strict manure management system must be applied in order to protect ecosystem. Hence, whether increasing of M&L livestock farm biogas projects in this region is appropriate, will be assessed through environmental analysis in entire 'manure-biogas-agricultural' system.

The case study 2 is about a dairy industry in inner Mongolia in China. All data comes from *Biogas Scientific Research Institute of the Ministry of Agriculture* in Chengdu. Inner Mongolia is a large region located along the northern edge of China, in which many dairy cow farms are built. (See *Figure 3.4*) The east of Inner Mongolia consists of wide grass meadow lands, forests and mountains. The winter in this area occupies half of a year and average temperature is below 28°C. The weather is humid between May and September. The west of the region is made up of scorching hot dry deserts, which is always hot in summer and extremely cold in winter. The dairy cow farm is located in the eastern part of Inner Mongolia. Inner Mongolia had total land area 5.37 million hectare, in which arable land occupies 0.59 million hectare, pasturueland land is 2.53 million hectare and forest land are 0.24 million hectare. In 2008, net arable land increased by 1000 hectare corresponding to an average of unit arable land surpasses 0.67 ha per farmer. Due to large quantity of dairy cow manure in this region, the development of biogas production from livestock manure and application of digestate to soil have attracted most attention.



Figure 3.4 Map of Inner Mongolia [42]

Before cow manure was used for biogas production in anaerobic digester, dairy cow manure used to be treated by combustion for heating purpose. Combust manure with low energy conversion efficiency leads to large amount of GHG emission and smoke produced by combustion oven results in poor living environment, even affected people's health. When renewable energy policy and strict environmental standard were launched by central government, most of dairy cow industries started to integrate cow husbandry into biogas production and waste water treatment, in order to fulfil national requirement.

At first, 'energy-environmental' biogas system were commonly used in dairy industry. It is seen as the reference system on which scenario 1 is built in case study 2. Biogas produced by anaerobic digestion of cow manure is delivered from central plants on farm to residents living surrounding by biogas pipe and the biogas replaced straw and firewood as the major energy resources for heating and cooking. The waste water from livestock farm was treated by aerobic pond to reduce COD and $\text{NH}_3\text{-N}$ concentrate to fulfil national discharged water standard. Although this system has brought benefit to dairy industry both from economic and environmental perspective, two main problems has emerged as an effect of the fast urbanization in this region. The first is about the change of traditional energy structure in the region. With urbanization enlarged, heating is mainly supplied by coal combustion and electricity is bought from national grid which is also generated by coal. Straw and firewood demand are reduced year by year, the large GHG emission are foremost produced by electricity generation from coal power plants. Secondly, with increasing demand of food and crops, waste water from livestock farm with too much nutrients should be made use of in agriculture rather than discharged. The digestate is suggested to be applied to soil in order to substitute of industrial fertilizer. Hence, 'energy-ecological' biogas system is put forward by many experts and gets more concern by farm-owner and it is the suggested system reflected in scenario 2 of case study 2.

3.2.2 GHG emission calculation of case study 2

1. Basic information about case study 2

This dairy cow farm located in Inner Mongolia breed 10,000 cows for milk supply, which feed biogas plants with 280 tons manure and 200 tons urine every day. The influent flow rate to biogas plants and biogas yield are shown in *Table 3.10* below. Before electricity turbine introduced to farm, the biogas produced was delivered by pipeline to residents' living nearby. The wastewater from digester is required to be treated as national chemical standard before discharged. The new design concept of biogas project on this cow farm focuses on electricity generation and digested residue utilization as organic fertilizer for pastureland. The functional unit of M&L farm based biogas system is based on ton dairy cow manure treated by anaerobic digestion per day. The manure is produced by total 10,000 heads of dairy cow per day. The influent to biogas digester on dairy farm includes dairy cow manure and urine, and wastewater of flashing manure per day; the effluent points out slurry produced at the end of pipe.

Table 3.10 Biogas potential of feedstock based on functional unit (m³)

Substrate	Quantity of feeding (ton/day)	TS %	Biogas producing rate (m ³ /kg TS)	Biogas yield(m ³)	Energy content(MJ)
Cow manure	280	16.7	0.25	11690	245,490
Urine	200	0			
Waste water	160	0			

To environmental consideration, national form of chemical content in effluent from livestock farm is required to fulfil when wastewater discharged. *Table 3.11* is the chemical content of influent to biogas system in this case study and *Table 3.12* illustrates the national form of chemical content of effluent and the chemical removal ratio based on influents and national standard.

Table 3.11 Chemical content in influent to biogas system (kg). This figure is based on functional unit.

Substrate	Quantity (ton/ day)	COD (kg/ton)	BOD (kg/ton)	TN (kg/ton)	TP (kg/ton)	NH ₃ -N (kg/ton)
Cow manure	280	31	24.53	4.37	1.18	1.7
Urine	200	6	4	8	0.4	3.5
Wastewater	160	0	0	0	0	0
Concentration		16654.3	12926.3	4759.6	691.8	1982.3

mg/L						
Concentration kg		9880	7668.4	2823.6	410.4	1176

Table 3.12 National chemical standard of effluent discharged from livestock farm and responding chemical removal ratio [43]

	COD	BOD	NH3-N	P
Concentrate mg/L	400	150	80	8
Chemical removal %	97.6	98.8	96	98.8

2. GHG emission from scenario 1 in case study 2

GHG emission from biogas production process of scenario 1

In the ‘energy-environmental’ biogas system (*Appendix 8*), the cow manure and waste water is primarily treated by solid-liquid separation process after pre-treatment, which can reduce COD and VS content in slurry. (See *Table 3.13*) After then, 65.6% of VS and 39.8% of TN can flow into dewatered system for solid composting and the rest VS and TN is contained in liquid after separation inflow to anaerobic digestion. The UASB is the type of anaerobic digester selected in this system, which can remove 86.7% of VS and 70% of TN [44] and SBR can reduce 75% of TN and 60% of VS. The slurry produced after fermentation of feedstock in anaerobic digester must be discharged after aerobic treatment in order to fulfil the national form of waste water discharged from livestock farm. Biogas in this system is transported by biogas pipe to residents living around. It assumed the transport distance is not so long that methane leakage is not taken into consideration. The GHG emission abatement in biogas utilization in ‘energy-environmental’ biogas system is relied mostly on the traditional energy structure in specific site.

Table 3.13 VS content of dairy manure for biogas production (ton)

Feedstock	Quantity of feedstock ton/day	TS %	VS %TS	Quantity of VS
Cow manure	280	16.7	74	34.6
Urien	200	0		
Waste water	160	0		

The GHG emission produced from different phases of biogas production system is calculated as IPCC guideline which is stated in Chapter 2. All the CH₄ and N₂O emission are calculated as *IPCC guideline-Volume4*. The quantity of manure treatment for composting is based on VS removed from separation phase and moisture

content in composting, which is appropriate at 55%-60%. The GHG emission from USAB is regarded as that from dairy manure treated by anaerobic digester and that produced from aerobic lagoon is based on *IPCC guideline volume 4* as well. See from *Table 3.14*, the CH₄ emission is mainly produced from solid-composting and the largest N₂O emission potential is from aerobic treatment compared to low TN content is very low in influent.

Table 3.14 GHG emission produced from biogas production process of 'energy-environmental' biogas system. All the figures are based on functional unit. (ton)

	Influent (ton)		Effluent (mg/L)		GHG emission (ton)		
	TN	VS	TN	COD	CH ₄	N ₂ O	CO ₂ -equ
Soild-composting	1.12	22.7	---	---	0.02	0.018	5.89
UASB leakage ¹²	1.68	11.9	---	---	0.06	0	1.27
Aerobic process	0.51	1.41	214.5	324.3	0	0.04	12.4
Total GHG emission from biogas production (ton)					0.08	0.058	19.56

Based on removal ratio of chemical content in influent to every phase during biogas production, the concentration of TN and COD left in slurry are shown in *Table 3.14*. According to national form of chemical content in effluent from livestock farm, concentration of COD fulfils the national requirement ≤ 400 mg/L COD.

GHG emission abatement from energy substitution of scenario 1

In the 'energy-environmental' biogas system, [44] the biogas is produced when dairy cow manure and wastewater are treated by anaerobic digester. The biogas is transported by pipeline to resident's house nearby which substitutes of heat produced by coal. Hence, the GHG emission abatement is calculated as the GHG emission produced by coal combustion minus GHG emission produced by biogas combustion. The coal combustion efficiency is 40% and biogas combustion efficiency is 60%. However, due to process of biogas production, VS concentration is reduced by seperation before entering AD, which is only 34.4% of total VS content in influent. Hence, in the *Table 3.18*, the total biogas yield is only 34.4% of 11690 m³ biogas production. 35186 kwh of coal equivalent to 23458 kwh of biogas is consumed. Different from household biogas project, the anaerobic digester needs external heating which is equal to 30% of total energy production for digester operation during winter, which is also substituted by biogas. Hence, the total GHG emission abatement equals to emission from coal combustion. The CO₂-equ emission abatement from energy substitution part in 'energy-environmental' biogas system is 11.64 ton per day in the dairy cow farm. (See *Table 3.15*)

¹² The CH₄ leakage from UASB is assumed as 3% of total CH₄ produced from digester, based on IPCC guideline.

Table 3.15 GHG emission abatement produced from biogas substituting of coal combustion, the figure is based on functional unit. (ton)

Energy fuel	Energy end-use ¹ (kwh)	Combustion efficiency (%)	Energy input (kwh)	GHG emission (ton)			
				CO ₂	CH ₄	N ₂ O	CO ₂ -equ
Biogas	13644.7	60	22741.2	0	0	0	0
Coal		40	34111.8	11.6	0.0012	0	11.64
GHG emission abatement from energy perspective (ton)				11.6	0.0012	0	11.64

*1. Energy input=Energy end-use /combustion efficiency; 1 m³ biogas=21 MJ=5.83 kwh;

3. GHG emission from scenario 2 in case study 2

GHG emission from biogas production process of scenario 2

Due to TN and COD removal rate of different phases during biogas production in 'energy-ecological' system, the concentration of TN and COD reduced a lot in effluent from slurry storage tank. (See Table 3.16) The slurry is applied on the pastureland which is regarded as a substitution of synthetic ammonium.

Table 3.16 GHG emission produced from biogas production process of 'energy-ecological' biogas system. All the figures are based on functional unit. (ton)

	Influent (ton)		Effluent (mg/L)		GHG emission (ton)		
	TN	VS	TN	COD	CH ₄	N ₂ O	CO ₂ -equ
USR	2.8	34.6	---	----	0.17	0	3.7
Composting	1.13	3.4	---	---	0.003	0.018	5.6
Slurry storage tank	0.55	1.8	856.7	2498.1	0.1	0.004	3.4
Total GHG emission from biogas production (ton)					0.273	0.022	12.63

The GHG emission from biogas production process is divided into three phases, the emission from USR anaerobic digester, solid-composting and slurry storage tank. When feedstock entering into USR, all of feedstock weight is calculated. 3.7 ton of CO₂-equ emission is produced from anaerobic digestion based on IPCC guideline—livestock manure management. The organic waste to be treated in solid-composting is reduced by VS removal. 10% of total VS contained in mixture for composting with 55% moisture content. The total waste mass for composting is 2.32 ton. In slurry tank, the GHG emission is calculated as slurry storage, the VS of influent is 1.8 ton and TN content is 0.55 ton. From Table 3.16, the GHG emission from process per functional unit is 12.63 ton, in which the methane emitted from slurry storage tank contributes

the most with least VS content in feedstock, and the largest N₂O emission is from solid-composting phase.

GHG emission abatement from energy substitution of scenario 2

Based on *Table 3.17*, biogas output from anaerobic digestion of feedstock is 11,339 m³/functional unit. Electricity generated from CHP is 23,676 kwh/functional unit with electricity efficiency 36% and heat production is 29,596 kwh/functional unit with heat efficiency 45%.

If the same amount of electricity is generated by coal, the emission produced is regarded as the emission abatement from electricity produced by biogas. In addition, the exhausted heat recovers the external heat demand, which can also be seen as the GHG emission abatement in energy substitution part.

Table 3.17 GHG emission abatement produced from CHP by biogas substituting of coal (ton)

Energy fuel	Energy end-use (kwh)		Energy input(kwh)	GHG emission (ton)			
	Electricity	Heat		CO ₂	CH ₄	N ₂ O	CO ₂ -equ
Biogas	23676	29596	65768	0	0	0	0
Coal	23676		72274	24.6	0.0026	0.0004	24.8
Coal ²		29596	73989	25.2	0.0027	0.0004	25.4
GHG emission abatement from energy perspective (ton)							50.2

*1 kwh electricity consume 379g coal. Coal combustion efficiency is 40%. Coal² means the coal provided for external heating source of digester.

GHG emission abatement from industrial fertilizer substitution of scenario 2

N content in feedstock is 0.55 ton of functional unit. Based on N removal ratio of different phases of biogas production process, the TN in slurry which applied on soil to replace the synthetic ammonium is 0.33 ton with TN removal rate 82%. The GHG emission abatement from slurry for fertilizer substitution is seen as the direct GHG emission abatement in agricultural part. Because 60% of N in slurry is taken up by plants as NH₄⁺, synthetic ammonia can be replaced the same amount of 60% of total N in slurry. The GHG emission produced from synthetic ammonia production and utilization are shown in *Table 3.18*.

Table 3.18 GHG emission from synthetic ammonia production and utilization, the total GHG emission from agricultural perspective is based on functional unit (ton)

Synthetic ammonia (NH ₄ ⁺) input	TN-equ in cow manure (ton)	NH ₄ ⁺ /TN in cow manure (%)	Synthetic ammonia substitution (ton)	Coal for ammonia production (ton)	GHG emission (ton)			
					CO ₂	CH ₄	N ₂ O	CO ₂ -equ
Production	0.55	60	0.33	0.73	2	0	0	2

Utilization					0.12	0	0.003	0.94
Total GHG emission from ammonia (ton)					2.12	0	0.003	2.93

When the same amount of synthetic ammonia applied on soil, the direct N₂O and indirect N₂O are the main GHG emission from soil. The GHG emission is calculated based on IPCC guideline. And the GHG emission from digestate applied on soil is written in *Table 3.19*.

Table 3.19 GHG emission abatement from agricultural perspective of 'energy-ecological' biogas system and this figure is based on functional unit. (ton)

Fertilizer utilization	TN content (ton)	Digestate input (ton)	Emission (ton)			
			CO ₂	CH ₄	N ₂ O	CO ₂ -equ
Ammonia	0.55	0.33	2.12	0	0.003	2.93
Digestate		0.55	0	0	0.005	1.63
Total GHG emission abatement from agricultural perspective (ton)			2.12		-0.002	1.3

4. Results

This Chapter includes the results of GHG emission abatement from case study 1 and case study 2 through comparison of two scenarios in each case study, and future estimation based on GHG emission abatement of two case studies.

4.1 Results of GHG emission abatement and future estimation of case study 1

4.1.1 Results of GHG emission abatement of case study 1

1. Results of GHG emission from scenario 1 in case study 1

CO₂, CH₄ and N₂O emission from three parts of traditional household system are concluded in the *Table 4.1*. Through comparison among the GHG emissions from different parts, it is clear to see that the CO₂ emission is mainly produced by traditional energy fuel combustion which occupies the largest share of the total GHG emission in the whole system. However, CH₄ emission produced from traditional manure management system is more than that from other parts, especially from slurry and uncovered anaerobic lagoon as well as the N₂O emission. Compared among these three manure treatment, except composting, the GHG emission from other two occupy for more than 50% of total emission from entire system. From agricultural perspective, large reliance on industrial fertilizer will lead to CO₂ emission from fertilizer production phase and ammonia utilization will result in N₂O emission and NH⁴⁺ leaching from soil, which cause eutrophication to aquatic system.

Table 4.1 Comparison of GHG emission from three parts of traditional household system (kg/functional unit)

GHG	Saving of coal and firewood	Slurry	Uncovered lagoon	Compost	Avoid from fertilizer production	Avoid from fertiliser utilization
CO ₂	578				120.7	7.3
CH ₄	0.124	43	52.23	0.66	0.013	0
N ₂ O	0.017	0.58	0.32	0.84	0.002	0.16
CO ₂ -equ	585.4	1082.2	1196	274.1	122	57
Total CO₂-equ		1846.6	1960.4	1038.5		

2. Results of GHG emission from scenario 2 in case study 1

See from *Table 4.2*, CO₂-equ emission from anaerobic digestion occupies 65% of total GHG emissions due to 10% of biogas is leaked from system with methane

content is 60%. The organic fertilizer applied on soil contributes the largest N₂O emission of entire system.

Table 4.2 Comparison of GHG emission from three parts of household biogas system (kg/functional unit)

GHG emission	Biogas combustion	Anaerobic system	Organic fertilizer
CO ₂	0		
CH ₄	0.003	6.11	
N ₂ O	0.0003		0.32
CO ₂ -equ	0.15	128.3	67
Total CO₂-equ	195.45		

3. Results of GHG emission abatement between two scenarios in case study 1

From *Table 4.1* and *Table 4.2*, the GHG emission abatement from household biogas system is obvious drawn in conclusion (See *Table 4.3*). The result from the comparison has shown the GHG emission abatement from biogas system when substituting traditional household system. Based on different traditional system adopted in rural areas, under MMS as slurry and uncovered anaerobic lagoon without natural crust, the most important emission abatement is due to manure management substitution followed with traditional energy fuel replacement. While, if composting is the main manure treatment used, biogas substitution contributes the most to GHG emission abatement in entire system. In digestate utilization perspective, the GHG emission is reduced by substitution of ammonia applied on soil as well as ammonia production.

Table 4.3 GHG emission abatement from household biogas system substitution (kg/functional unit)

	Energy substitution	Manure management system substitution			Fertilizer substitution
		Slurry	Uncovered lagoon	Composting	
CO ₂ -equ abatement	585.25	953.9	1067.7	145.8	112
Total CO₂-equ emission		1651.2	1765	843.1	

abatement				
-----------	--	--	--	--

4.1.2 Future estimation of GHG emission abatement of case study 1

1. GHG emission abatement from changing share of energy fuel in RES

According to development of rural areas in western China, the main energy to be substituted by biogas are coal and firewood. With economic development of rural China, coal will gradually dominate the rural energy consumption. In Chapter 1, it has mentioned that the growth of domestic coal consumption will increase 3-5% annually during 2006-2010 and 1-2% during 2010-2020 every year. [27]The future estimation done here is to calculate GHG emission abatement in 2005, 2010 and 2015 with coal increased and firewood reduced at the max and min ratio perspective (See *Table 4.4^a* and *Table 4.4^b*). The changes of GHG emission abatement of biogas substitution in rural area is concluded in *Table 4.5^a* and *Table 4.5^b* and future estimation of GHG emission abatement from energy perspective of household biogas system is shown in *Table 4.6^a* and *Table 4.6^b* with min and max coal increased in RES.

Table 4.4^a Share of coal and firewood in rural RES with min coal increased (2005-2015)

Energy fuel growth ratio	2005	2010	2015
Coal	32%	37%	39%
Firewood	24%	19%	17%

Table 4.5^a Change of GHG emission abatement with coal consumption increased at 3% (2005 -2010) and 1% (2010-2015) annually. (kg/functional unit)

ERES _{GHG fuel}		2005		2010		2015	
Coal ¹³	Firewood	57%	43%	66%	34%	70%	30%
CO ₂ -equ abatement		234	351.5	271	278	287	245

Table 4.6^a Future estimation of GHG emission abatement from energy perspective of household biogas system with min coal increased in RES (kg/functional unit)

ERES _{GHG fuel}	Saving GHG emission	Biogas	GHG emission

¹³ Coal and firewood will be substituted by biogas totally, of which the share is calculated based on their shares in rural RES.

	from coal and firewood			combustion	abatement		
	2005	2010	2015		2005	2010	2015
Ratio of energy							
CO ₂ -equ emission	585.5	542	532.6	-0.15	585.4	541.7	532.5

Table 4.4^b Share of coal and firewood in rural RES with max coal increased (2005-2015)

Energy fuel growth ratio	2005	2010	2015
Coal	32%	41%	45%
Firewood	24%	15%	11%

Table 4.5^b Change of GHG emission abatement with coal consumption increased at 5% (2005-2010) and 2% (2010-2015) annually. (kg/functional unit)

ERES _{GHG fuel}		2005		2010		2015	
Coal	Firewood	57%	43%	73%	27%	80%	20%
CO ₂ -equ abatement		234	351.5	300	220.7	328.4	163.5

Table 4.6^b Future estimation of GHG emission abatement from energy perspective of household biogas system with max coal increased in RES (kg/functional unit)

ERES _{GHG fuel}	Saving GHG emission from coal and firewood			Biogas combustion	CO ₂ -equ emission abatement		
	2005	2010	2015		2005	2010	2015
Ratio of energy							
CO ₂ -equ emission	585.5	520.4	491.9	-0.15	585.4	520.2	491.8

From result of comparison of GHG emission abatement from coal and firewood consumption changed, it is clear to see that the more coal consumed, the less GHG emission abatement results from biogas substitution in energy perspective. When assessing total GHG emission abatement from entire household biogas system

(scenario 2), the emission abatement from MMS and agricultural perspective are included, which are assumed to keep stable as scenario 1. The *Figure 4.1* shows the change of GHG emission abatement of entire household biogas system (scenario 2) with min and max coal consumption increased in case study 1. Because in traditional household system, the manure management system is considered as three types, the GHG emission abatement from household biogas system substitution is also represented by these three categories.

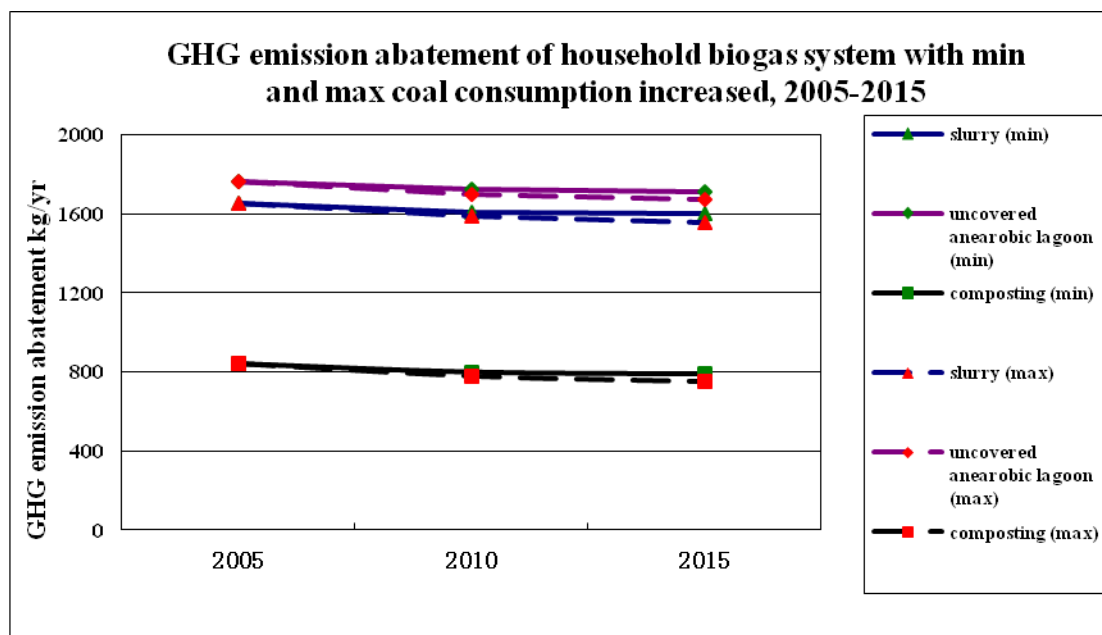

Figure 4.1 GHG emission abatement of household biogas system with min and max coal consumption increased, 2005-2015

From *Figure 4.1* above, it is obvious to see that if the coal consumption increased 3% annually from 2005-2010 and 1% from 2010-2015 (min growth ratio), the GHG emission abatement reduced at 2.5-3% (uncovered anaerobic lagoon), 2.6-3.2% (slurry/liquid storage) and 5-6.2% (composting) at the end of 2010 and 2015 compared to that in 2005; And if the coal consumption increased with max ratio, the GHG emission abatement decline at 3.7-5.3% (uncovered anaerobic lagoon), 4-6% (slurry/liquid storage) and 7.8-11% (composting) at the end of 2010 and 2015. Compared with traditional household system, three MMS used in reference system plays the most important role in emitting GHG emission. Hence, although GHG emission abatement in energy perspective reduced, total emission abatement is not effected obviously. Due to large emission produced from MMS, the total GHG emission abatement can only be achieve if the slurry is implemented. The effect of energy pattern change to GHG emission abatement in entire system is larger if household adopted composting as their manure treatment than the others.

2. GHG emission abatement from changing share of digestate applied to soil

When the arable land area per household changed, total amount of N contained in swine manure cannot be applied on land based on 15.3 kg N/mu from report of N fertilizer consumption in 2007. The left digestate is assumed to be treated by composting. GHG emission produced from composting is need to be considered. The digestate is removed twice a year which aims to irrigate on soil. Hence, the N

contained in digestate for once irrigation is 16.65 kg/mu.yr which equals to 10kg/mu.yr (150 kg/ha.yr). Based on requirement of N fertilizer applied on soil in Chapter 1, the most appropriate N fertilizer is 150-180 kg/ha.yr. Hence, the digestate fulfil the requirement. The GHG emission abatement from agricultural perspective per functional unit (one year) is shown in *Table 4.7*.

Table 4.7 GHG emission abatement from digestate application (kg/function unit)

Arable land area mu/household	1	0.96	0.84
N content of swine manure kg/functional unit	33.3	33.3	33.3
N content in digestate applied kg/functional unit	33.3	32	28
Synthetic ammonium kg/functional unit	19.98	19.2	16.8
CO ₂ -equ abatement from ammonium replacement	179	172	150
Left digestate for composting Kg/functional unit	0	1.3	5.3
CO ₂ -equ emission from composting	0	1.8	7.3
CO ₂ -equ emission from digestate	67	64.3	56.3
Net CO ₂ -equ abatement from soil	112	105.9	86.4
Reduction of GHG emission abatement from agricultural perspective (%)		5%	23%

If take the entire household biogas system (scenario 2) into consideration, the reduction of GHG emission abatement is shown in *Figure 4.2* as following.

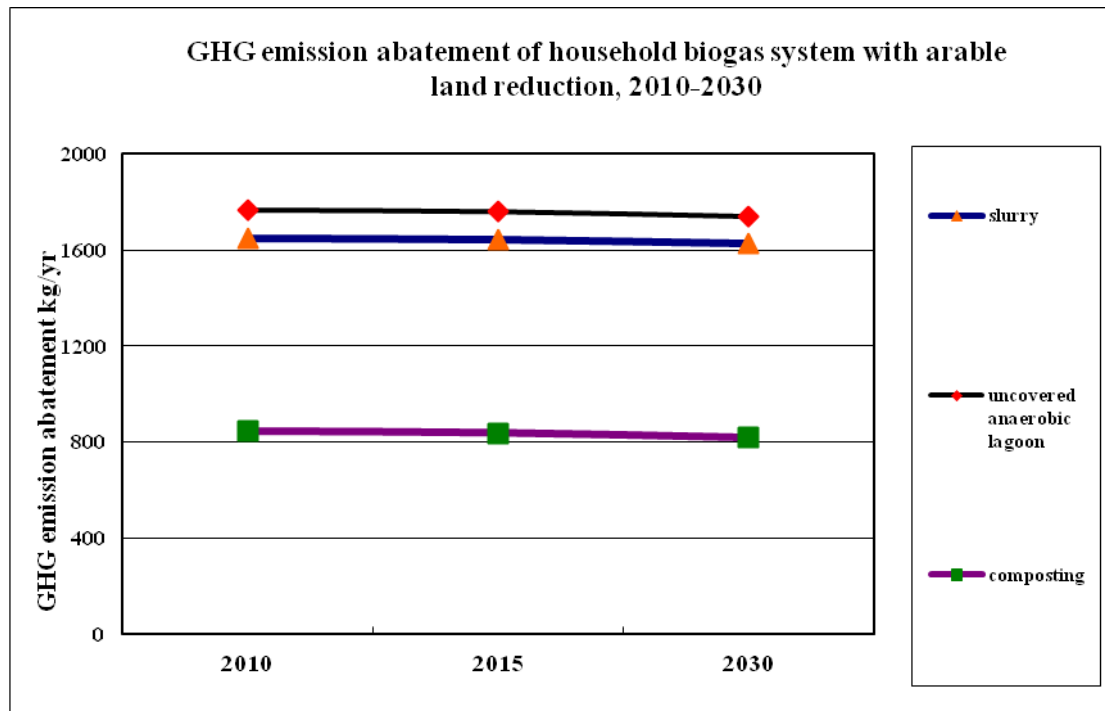

Figure 4.2 Reduction of GHG emission abatement from entire household biogas system with arable land area changed, 2010-2030

When arable area shrunk with 4% and 16% at the end of 2015 and 2030, net GHG emission abatement from entire household biogas system will reduce 0.04%, 0.03% and 0.08% at the end of 2015 and 0.02%, 0.016% and 0.03% at the end of 2030 compared to that in 2010, which are categorized as slurry/liquid storage, uncovered anaerobic lagoon and composting used in reference system. Although the shrink of arable land area will not lead to so much reduction to GHG emission abatement from entire household biogas system substitution, it has large negative effect to agricultural perspective of biogas system. See from *Table 4.7*, with arable land area reducing 5% and 23%, more CO₂-equ emission will be produced from composting of the rest digestate which cannot be applied on soil.

3. Results of future estimation of case study 1

The conclusion drawn from future estimation above represents how GHG emission abatement reduced with changes of future rural energy pattern and household arable land area, which is based on results of GHG emission abatement of case study 1.

- In energy substitution part, the GHG emission abatement is reduced more obviously from energy perspective than in entire system when household biogas system substitution with increasing of coal consumption in rural area in following years;
- In digestate utilization part, arable land area plays an important role in reducing GHG emission abatement from agricultural perspective rather than from entire household biogas system.
- The GHG emission abatement in system substitution is mostly effected by household AD replacing of traditional manure treatment.

4.2 Results of GHG emission abatement and future estimation of case study 2

4.2.1 Results of GHG emission abatement from case study 2

1. Results of GHG emission abatement from scenario 1 in case study 2

In ‘energy-environmental’ system, the GHG emission abatement is from energy substitution part and GHG emission is produced from biogas production process. The GHG emission abatement from this system is shown in *Table 4.8*. Although biogas can replace of coal as heating resources used by residents, the GHG emission also produced during biogas production process. The result shows the emission from process is less than emission abatement from energy substitution which achieves the emission abatement. The GHG emission reduced by ‘energy-environmental’ system is 5.57 ton per day and 2033 tons per year. Hence, M&L livestock farm shouldn’t only take environmental impact of discharged water into consideration; reduce the external heat for biogas production and GHG emission from biogas production process are necessary to be concerned.

Table 4.8 GHG emission abatement from ‘energy-environmental’ biogas system (ton)

The figure is based on functional unit

CO ₂ -equ emission abatement from biogas substitution	CO ₂ -equ emission abatement from biogas production process	CO ₂ -equ emission abatement from ‘energy-environmental’ biogas system
11.64	-19.56	-7.92

2. Results of GHG emission abatement of scenario 2 in case study 2

From *Table 4.9*, it is obvious to see that the GHG emission is reduced largely in energy substitution part of system. The electricity produced by biogas through the gas turbine is transport by electricity grid to residents and exhaust heat can be recovered to heat the digester which can save fossil fuel for heating digester in winter. In biogas production process, amount of GHG emission is from composting, particularly the N₂O emission. As for digestate utilization on soil, it can reduce the synthetic ammonium consumption and avoid responding amount of fossil fuel for fertilizer production.

Table 4.9 GHG emission abatement from ‘energy-ecological’ biogas system (ton) The figures are based on functional unit.

CO ₂ -equ emission abatement from biogas substitution	CO ₂ -equ emission abatement from biogas production process	CO ₂ -equ emission abatement from digestate substitution	CO ₂ -equ emission from ‘energy-ecological’ biogas system
50.2	-12.63	1.3	38.87

3. Results of GHG emission abatement between two scenarios in case study 2

In 'energy-environmental' biogas system, the GHG emission abatement from energy substitution is only 11.64 ton based on functional unit. The inefficiency of biogas production and low heat value of biogas is the main reason to less GHG emission abatement from energy perspective. What's more, because the main focus of 'energy-environmental' system is on its treatment of discharged water, which names the chemical content of effluent from system must fulfil the national environmental standard, the VS content of feedstock to AD is reduced mostly in solid-liquid separation phase. And this leads to less biogas production from anaerobic digestion process. However, the GHG emissions are produced from biogas production process due to methane leakage (10% of total biogas production) from AD and aerobic process (SBR). Hence, GHG emission produced from AD process is more than emission abatement from energy substitution perspective in 'energy-environmental' biogas system.

Compared to 'energy-environmental' biogas system, 'energy-ecological' biogas system leads to less GHG emission from biogas production process but more COD and TN content in effluent. Larger arable land is needed if all digestate from 'energy-ecological' biogas system is applied. GHG emission abatement from this system is achieved by biogas utilization. CHP is implemented for electricity generation from biogas. Compared to heat efficiency of coal, electricity production efficiency from coal combustion is less, which leads to larger GHG emission abatement when biogas replaces of coal for electricity production rather than only heat purpose..

As for fertilizer substitution part of both systems, only direct GHG emission abatement is taken into consideration. The solid after composting will sell in the market and use as organic fertilizer. However, this part is not concerned when assessing the GHG emission abatement from biogas system. The main purpose of 'energy-ecological' biogas system is to make use of nutrients contained in digestate on soil. The emission abatement from synthetic ammonia replacement is a little bit less than that from digestate applied on soil, but that from coal used for fertilizer production is 1.99 ton. In a word, in 'manure-digestate' part, the environmental benefits is 0 in 'energy-environmental' system, but 31.3 ton GHG emission abatement in 'energy-ecological' system per day.

4.2.2 Future estimation of GHG emission abatement in case study 2

1. GHG e mission abatement from changing share of energy fuel in urban RES

Natural gas will increase 11-13% every year during the next 15 years [27], which is introduced in Chapter 1. Natural gas in future estimation here is only assumed to replace of coal for heating purpose and to provide heat for residents. With natural gas growing, the coal will reduce the same ratio at the same time. The electricity generation and digester heat are still from coal-power plants. Hence, only 'energy-environmental' biogas system (scenario 1) is effected, the 'energy-ecological' biogas system (scenario 2) keeps the same GHG emission abatement in future estimation. The change of energy fuels shares in RES are shown in *Table 4.10^a* and *Table 4.10^b* with min and max of NG increased, with which the change of GHG emission abatement is shown in *Table 4.11^a* and *Table 4.11^b*. The total GHG emission

abatement from energy perspective of ‘energy-environmental’ biogas system is demonstrated in *Table 4.12^a* and *Table 4.12^b*.

Table 4.10^a Share of coal and NG in urban RES with min NG increased (2005-2015)

Energy fuel growth ratio	2010	2015	2020
Coal	100%	83.3%	71.9%
Natural gas	0	16.7%	28.1%

Table 4.11^a Change of GHG emission abatement with NG consumption increased at 11% (2010-2020) annually. (ton/functional unit)

ERES _{GHG fuel}		2010		2015		2020	
Coal	NG	100%	0	83.3%	16.7%	71.9%	28.1%
CO ₂ -equ abatement		11.64	0	9.7	1.2	8.4	2.02

Table 4.12^a Future estimation of GHG emission abatement from energy perspective of ‘energy-environmental’ biogas system with min NG increased (ton/functional unit)

ERES _{GHG fuel}	Saving GHG emission from traditional energy fuel			Biogas combustion	CO ₂ -equ emission abatement from energy perspective		
	2010	2015	2020		2005	2010	2015
Year	2010	2015	2020		2005	2010	2015
CO ₂ -equ emission	11.64	10.9	10.39	0	11.64	10.9	10.39

Table 4.10^b Share of coal and NG in urban RES with max NG increased (2005-2015)

Energy fuel growth ratio	2010	2015	2020
Coal	100%	78.8%	61%
Natural gas	0	21.2%	39%

Table 4.11^b Change of GHG emission abatement with NG consumption increased at 13% (2010-2020) annually. (ton/functional unit)

ERES _{GHG fuel}		2010		2015		2020	
Coal	NG	100%	0	78.8%	21.2%	61%	39%
CO ₂ -equ abatement		11.64	0	9.17	1.52	7.1	2.9

Table 4.12^b Future estimation of GHG emission abatement from energy perspective of 'energy-environmental' biogas system with max NG increased (ton/functional unit)

ERES _{GHG fuel}	Saving GHG emission from traditional energy fuel			Biogas combustion	CO ₂ -equ emission abatement from energy perspective		
	2010	2015	2020		2005	2010	2015
Year	2010	2015	2020		2005	2010	2015
CO ₂ -equ emission	11.64	10.69	10	0	11.64	10.69	10

See from Table 4.12^a and Table 4.12^b, the GHG emission abatement from biogas substitution will decline with increase of natural gas utilization. In Table 4.12^a, when NG consumption increases 11% annually, the total GHG emission from coal and NG reduces 1.4% every year and GHG emission abatement will shrink with 2.3% per year. In Table 4.12^b, less GHG emission is produced along with NG consumption rising. When NG consumption increased as 13% annually, the GHG emission abatement will reduce as 3% every year, which means less GHG emission will be replaced by biogas.

When concerning the GHG emission abatement from 'energy-environmental' biogas system (scenario 1), the GHG emission from biogas production process needs to be included. Figure 4.3 demonstrates the reduction of GHG emission abatement from energy perspective and growth of GHG emission from 'energy-environmental' biogas system (scenario 1). It is clear to see that with min NG increased, the GHG emission from entire system will increase at 9% and 16% at the end of 2010 and 2015; And with max growth of NG consumption, GHG emission will grow 11% and 21% at end of 2010 and 2015 respectively. This result demonstrates that biogas used for heating purpose cannot reduce GHG emission obviously when natural gas is provided in suburb of livestock farm. The GHG emission will increase dramatically from 'energy-environmental' (scenario 1) biogas system if natural gas utilization still increases.

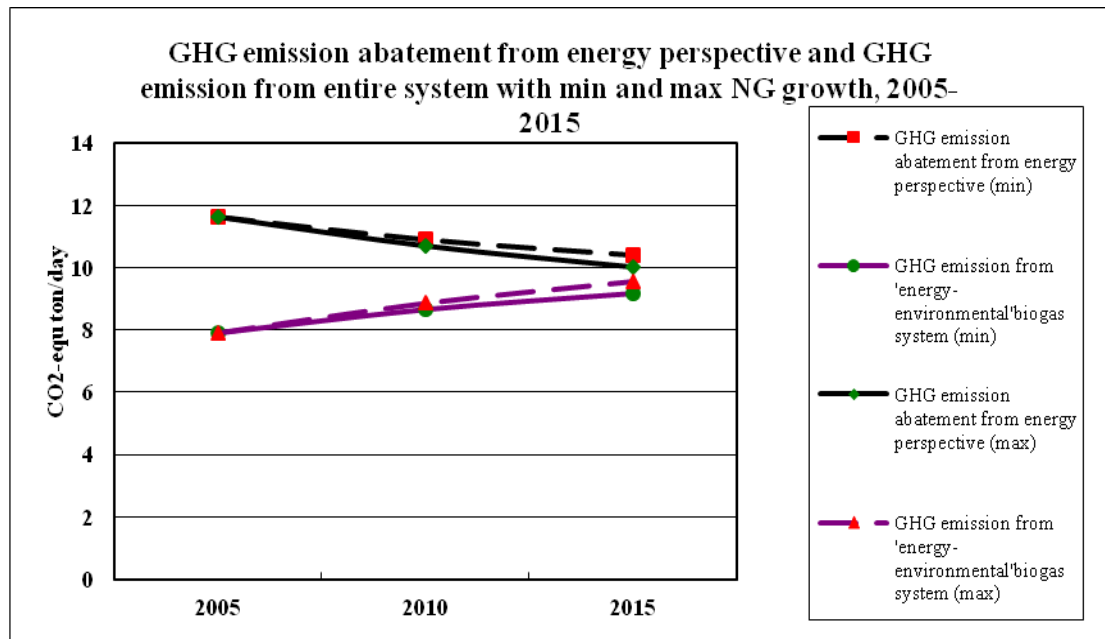

Figure 4.3 GHG emission abatement from energy perspective and GHG emission from 'energy-environmental' biogas system with min and max growth of NG consumption, 2005-2015

2. GHG emission abatement from changing share of digestate applied to soil

Due to digestate applied on soil is from 'energy-ecological' biogas system (scenario 2), the sensitivity analysis to GHG emission abatement from agricultural perspective is only done for this system. The aim is to point out how large area provided is right for digestate utilization. The COD and TN content contained in effluent from biogas system is written in Table 4.13. The slurry flow out of slurry storage tank will be applied to agricultural. The Table 4.14 shows how large agricultural land area is required to sustain these amount of chemicals.

Table 4.13 TN and COD content in slurry applied to soil. (kg/day)

Chemicals	Concentration in digestate
TN	550
COD	1800

Table 4.14. Required arable land area for sustaining chemicals in digestate (hectare)

Arable land	Rice	Wheat and maize	Vegetable
COD (kg/ha.yr)	<=2400	<=1350	<=1125
COD in digestate (kg/yr)	657000	657000	657000
Areas for COD (ha)	>=273.75	>=486.7	>=584
N-fertilizer demand	150-180	150-180	150-180

(kg/ha.yr)			
N-digestate (kg/ha.yr)	250-300	250-300	250-300
TN in digestate (kg/yr)	185420	185420	185420
Areas single crops for TN in effluent (ha)	618-742	618-742	618-742

According to *Table 4.14*, if COD and irrigation water quantity meets the national irrigation standard [45], the rice, wheat/maize and vegetable area should be more than 273.8ha, 486.7ha and 584ha perspective. Because the vegetable land area to be irrigated is variable depending on types of vegetables and rice is not appropriate to plant in Inner Mongolia, wheat and maize is discussed as an example of sensitivity analysis here. The min wheat/maize area is 133 hectare which is decided by COD content in digestate from dairy cow farm and national requirement of max COD in irrigation water, but in the range of 618-742 ha based on N-fertilizer input. In sensitivity analysis, the area land is assumed to be less than 618 ha, which means the slurry must be treated by aerobic lagoon before applied on soil, and more GHG emission will produce from it. If SBR aerobic lagoon used here, 60% COD and 75%TN is removed from digestate. The TN is 46355 kg/yr and COD is 262000 kg/yr left, and the appropriate crop land area is 155-185 ha. If the land area is between 155-185 ha, the COD content after SBR can fulfil national irrigation requirement of any kinds of arable land. The GHG emission abatement from SBR and digestate utilization are shown in *Table 4.15*.

Table 4.15 GHG emission from SBR and digestate application (ton)

Aerobic treatment and digestate application	Chemicals input (ton)		GHG emission (ton)			
	TN	COD	CO ₂	CH ₄	N ₂ O	CO ₂ -equ
SBR	0.55	1.8	0	0.00007	0.007	2.17
Digestate utilization	0.13				0.0024	0.75
Synthetic production	0.078		0.47	0.00005	0.00007	0.473
Synthetic utilization	0.078		0.028		0.0015	0.484
Total GHG emission abatement (ton)			0.5	0.00012	-0.008	-1.96

Hence, based on chemicals contained in digestate from ‘energy-ecological’ biogas system (scenario 2), the max and min required arable land area is 742 and 155 hectare. If the arable land area is less than 155 hectare, the livestock farm should change their biogas production process with environmental consideration. In the *Figure 4.4* below, the GHG emission abatement from agricultural perspective is reduced by 236% and that from entire ‘energy-ecological’ biogas system is only 5% reduction.

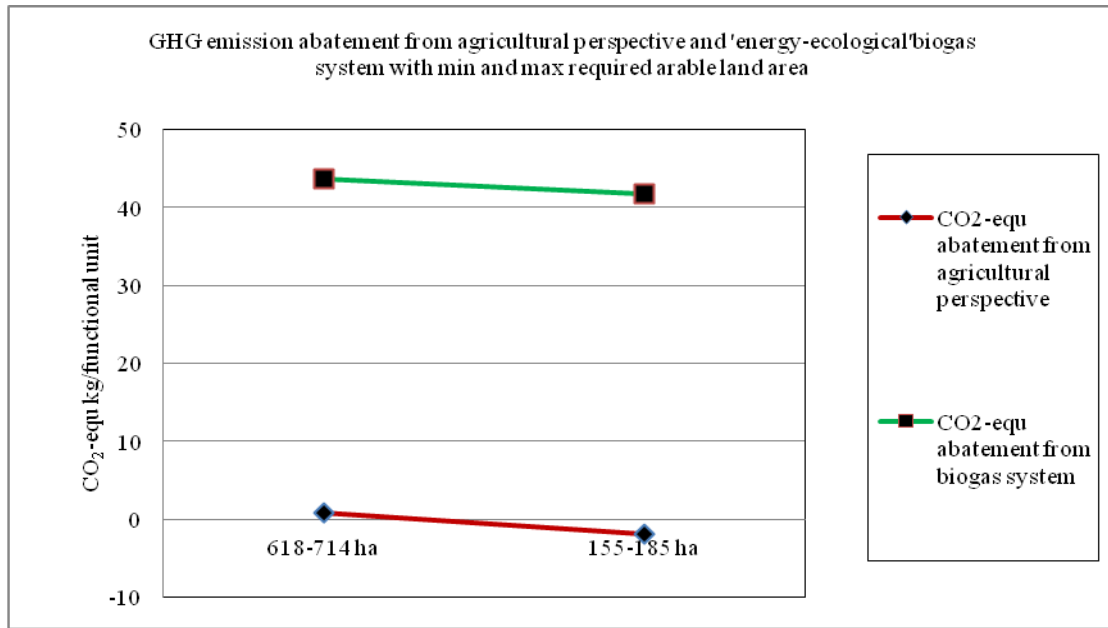

Figure 4.4 GHG emission abatement from agricultural perspective and 'energy-ecological' biogas system with min and max required arable land area

3. Results of future estimation of case study 2

- From energy perspective, with increasing of natural gas consumption in rural energy system, the GHG emission abatement will reduce due to higher heat value of natural gas and lower carbon content compared to coal. However, there is no any effect to electricity generation; because in China, coal is still the main energy fuel for power plant.
- In 'manure-digestate' part of system, whether digestate is appropriate to apply on soil should follow the national irrigation requirement, which set different standard to various kinds of plants. In the case study, wheat and maize are two major plants grown in Inner Mongolia, and the future estimation is concentrated on them. In order to fulfil the requirements of N-fertilizer input and COD concentration of effluent, the wheat and maize land area should be more than 618 ha. If crop land area is less than this data, the effluent must be treated by SBR. The GHG emission abatement from digestate application after treated by aerobic digester is -1.96 ton, in which the emission from SBR contributes the most. Hence, if there is no enough land area to sustain the N and COD content of digestate, the best way is to reduce its COD and N content by adding water.

5. Conclusion and discussion

5.1 Conclusion

Through GHG emission abatement calculation and future estimation from ‘manure-biogas-digestate’ system, household biogas system and M&L livestock farm-based biogas system are analyzed. There are two main differences existing in these two types of biogas systems. Firstly, in household biogas system, energy substitution is the motivation to develop the biogas projects, while in M&L livestock farm, the environmental concern is put in the first place. Secondly, biogas produced from household biogas system in rural China is based upon simplified household anaerobic digester with low efficiency and unstable when producing biogas; The M&L livestock farm always choose the most appropriate anaerobic digester based on VS content of feedstock in order to fulfil national requirement of discharged wastewater.

In household biogas system, the GHG emission abatement from biogas substitution of coal and firewood is obviously, however, the largest emission abatement results from AD substitution of traditional manure treatment. If the MMS in reference system is composting, the emission abatement from AD substitution is less than energy fuel replacement. While, if the traditional manure management system is slurry or uncovered anaerobic lagoon without natural crust, GHG emission abatement from household biogas system is quite large. During future estimation in household biogas system, the GHG emission abatement is reduced with small ratio when coal consumption increased. Hence, in rural areas, household biogas system definitely has great environmental potential because of positive environmental effect from MMS perspective.

‘Energy-environmental’ biogas system and ‘Energy-ecological’ biogas system are two the most common large-scale biogas project models used in M&L livestock farm. The foremost difference between these two is due to natural environment nearby. In ‘energy-environmental’ biogas system, in order to reduce nearly 90% of N and COD content in discharged water, the GHG emission is mainly produced from biogas production process which cannot achieve emission abatement goal from systematically perspective. While ‘energy-ecological’ biogas system has notable GHG emission abatement from both energy and agricultural perspective. However, if crop land area doesn’t have enough capacity to absorb all N and COD in slurry applied on soil, the aerobic treatment must be implemented before irrigation.

In a word, in order to achieve more GHG emission abatement from household and livestock farm-based biogas system in the future development, maximizing biogas yield and replacing synthetic ammonia fertilizers are both necessary measures to include in the whole ‘manure-biogas-digestate’ system.

5.2 Discussion

Through investigation of farmers who used household biogas digester in rural areas and business delegations involving in M&L livestock farm-based biogas project, the reflections to future biogas system development from them are not very optimistic. The opportunities and challenges of ‘manure-biogas-digestate’ system are concluded as followings:

5.2.1 Opportunities of future development

1. Environmental benefits

Most of farmers living in rural areas of China are active to implement the household biogas project due to its environmental benefits. In traditional household system, the smoke produced from firewood and straw combustion leads to severely indoor environmental problems. And odour from livestock manure in the open air effects the living atmosphere as well as large amount of manure compiled along road result in water and soil pollution. Meanwhile, large amount of synthetic ammonia fertilizers and pesticides are used for increasing crop and fruits yield per hectare without serious considering of food security and long-term soil productivity. Hence, household biogas project can provide clean and high heat value energy fuel (biogas) and produce organic fertilizer to farmers through anaerobic digestion of livestock manure, and reduce pollution caused by nitrogen volatilisation from manure spread in the open air.

2. Economic benefits

‘Manure-biogas-digestate’ system is regarded as a reasonable and profitable way to realize circular economy. To farmers in rural areas, manure as raw materials producing biogas is free to get and products (biogas and digestate) from anaerobic digestion can help them saving cost to buy energy fuels and industrial fertilizer. Most M&L livestock farm owners mainly concern to national subsidy and policy to green energy production. Especially, China intends to impose ‘carbon tax’ around 2012 [46], which is based on consumption quantity of fossil fuels in industry. The Chinese development and reform committee announce that the carbon tax will be set at 10 Yuan per ton CO₂ in 2012 and it will be raise up to 40 Yuan per ton CO₂ in 2020. Therefore, to implement of biogas project can bring profits to livestock farm and even build up their reputation. What’s more, large scale biogas project integrating with CDM has gained growth attraction. With imposing CDM into Chinese market [47], if GHG emission abatement from livestock farm-based biogas project is verified and CO₂-equivalent emission can be traded in international market, and this can enhance business internal profit and prolong their production chain.

5.2.2 Challenges of future development

1. Limitation of future development of rural household biogas system

In China, a large proportion of household biogas project cannot run successfully due to deficient professional training and education about anaerobic digester operation and maintenance to farmers. During interview, most farmers reflected that the digester is hard to restart in the spring after 3 months stop during winter. Moreover, through investigation of rural household biogas digester, it is common to see that most of digesters are used as a big rubbish lagoon, which is filled with any kinds of waste and the sludge at the bottom of digester is not removed periodically. All of these reasons can definitely result in unstable and low quality biogas production. What’s more, facing with low cost and convenient usage of coal and firewood, household biogas system not only has higher investment but also take time to build biogas digester.

2. Limitation of future development of livestock farm-based biogas system

The utmost important problem towards M&L livestock farm-based biogas project is how this big farm maximize their profits. The major benefit of livestock farms are from their livestock products trade. However, with renewable energy policy, industrial fertilizer consumption regulation and form of livestock manure management treatment launched, most livestock farms have been forced to adopt biogas project. Although there are subsidy to renewable energy offered by government, most of farm owners reflected this can only reduce the initial investment but higher maintenance cost cannot be covered, which enhance their economy load compared to traditional livestock business pattern. What's more, the solid concentration of influent to anaerobic digester on Chinese livestock farm is lower than that in Europe, which will produce less biogas but consume more energy to heat digester [48]. Moreover, to some livestock farms which are located far away from arable land, large amount of sludge will be treated by aerobic lagoon before discharged with increasing biogas demand. This also level up the investment and environmental risk. As for CDM, the ACM0010 is the basic methodology used for livestock sector [49]. However, with system boundary of livestock farm expanded to energy and agricultural system, GHG emission mitigation should be considered in a more complex system, which requires the new methodology for verifying GHG emission abatement integrating with real situation of Chinese livestock sector.

5.2.3 Suggestion to future development

The model of 'manure-biogas-digestate' system in this thesis plays an important role as a mathematic tool to assess GHG emission abatement from Chinese livestock sector connecting with energy and agricultural system. Under future estimation to energy consumption pattern changed, electricity generated from biogas has better environmental performance, which can integrate existing CDM methodology ACM0006 (Methodology of on-grid electricity produced from biomass residues) [50] and ACM0012 (GHG emission abatement from recovery of exhausted heat produced from electricity generation) [51] into ACM0010 (GHG emission abatement from livestock manure management system). Additionally, this thesis have also taken organic fertilizer applied on agricultural land into consideration, which leads GHG emission mitigation from soil management as well as avoided coal combustion for industrial fertilizer production. However, there is no existing methodology in CDM used in this aspect. Hence, the further research will try to develop new methodology in agricultural aspect focusing on soil management and integrate it into existing CDM methodology for energy and manure treatment aspects of entire 'manure-biogas-digestate' system.

What's more, with consideration of farmers' reflections, single household biogas system is suggested to be evolved to a district biogas system formed by central biogas plant and several animal breed household nearby. This can solve technical problems during anaerobic digester running, improve biogas yield by professional operation and allocate digestate to each household due to their crop land area. However, whether this type of biogas system can achieve more GHG emission abatement needs to be assessed based on 'manure-biogas-digestate' model. As for M&L livestock farm-based biogas system, the GHG emission abatement is obvious in 'energy-ecological' system. However, if arable land areas around livestock farm are in small size, the aerobic treatment should be implemented before digestate utilization. If the livestock

farm is far from arable land, CHP is suggested to be implemented in ‘energy-environmental’ biogas system which can help reducing GHG emission from biogas production process. The integration of ‘energy-environmental’ biogas system and ‘energy-ecological’ biogas system is needed with consideration of local environmental requirement.

Moreover, to integrate economic model into scientific and technical analysis of ‘manure-biogas-digestate’ system can make a more complete analysis to biogas system. In additional, economic profits is more convincing than environmental benefits to encourage people to implement biogas system in livestock sector. And economic model can also be regarded as a tool to assess whether ‘manure-biogas-digestate’ system can achieve ‘win-win’ strategy in economy and environment.

Reference

- [1] P.H, H.van. Exploring changes in the spatial distribution of livestock in China, *Agricultural systems* 62 (1999) 51-67.
- [2]. FAOSTAT
- [3] Wang W H, Chinese livestock manure production estimate and environmental impact, *China environmental science*, 2006;
- [4] STANK 2004, software program for calculating nutrient flows in agriculture. Swedish board of agriculture, Jönköping
- [5] Zhao J L, *Guide of environmental science*, China machine press, 2005
- [6] Technical Specifications for pollution treatment projects of livestock and poultry farms, HJ 497-2009, 2009
- [7] <http://www.zorg-biogas.com/library/biogas-production-process>
- [8] Ivet Ferreri Marti, Study of the effect of process parameters on the thermophilic anaerobic digestion of sewage sludge, evaluation of thermal sludge pre-treatment and overall energetic assessment, PHD thesis of Escola University, Barcelona, 2008
- [9] Dieter Deublein, *Biogas from waste and renewable resources—an introduction*, 2008
- [10] Klein E Lleleji, *Basics of energy production through anaerobic digestion of livestock manure*, Purdue University, ID-406-W
- [11] Maria Berglund, *Biogas production from a systems analytical perspective*, LTH lund university, 2006
- [12] Zhang FS, Wang JQ, Present situation and future improvement of apparent recovery efficiency of applied fertilizer for Chinese major crop, *Vol 45, No,5*, 2008-9
- [13] Chinese Ministry of Agriculture, *Chinese rural biogas project construction plan (2006-2010)*, 2007-3
- [14] J. Paul Henderson, P.Eng, *Anaerobic digestion in rural China*, Canada's Office of Urban Agriculture, 2009. <http://www.cityfarmer.org/biogasPaul.html>
- [15] Liu Yu, *Rural biogas project development and GHG emission abatement*, China population, resources and environment, Vol.18, No.3 2008 .
<http://www.docin.com/p-37856633.html>
- [16] Li Kangmin, *Biogas China*, ISIS report, 2006.
<http://www.i-sis.org.uk/BiogasChina.php>
- [17] Mir-Akbar Hessami, *Anaerobic digestion of household organic waste to produce biogas*, *Renewable energy* Volume 9, Issues 1-4, Australia, 1999.
- [18] Kestutis Navickas, *Biogas for farmin, energy conversion and environment protection*, Lithuanian University of Agriculture, Rakican, 2007
- [19] Montemurro F, *Anaerobic digestate and on-farm compost application*, *Compost science and utilization*, 2010

- [20] Peter Verburg and Youqi Chen, Multi-scale characterization of land-use patterns in China, *Ecosystems* (in press)
- [21] IPCC guidelines for national greenhouse gas inventories from livestock manure management system, Vol 4, 2006
- [22] Yang XY, Li QH, Research on nutrients balance of agricultural ecosystem in Shaanxi province, Northwest agricultural and technology university press, Vol 29, 2001-4
- [23] Zhang FS, Wang JQ, Present situation and future improvement of apparent recovery efficiency of applied fertilizer for Chinese major crop, Vol 45, No,5, 2008-9
- [24] Chang Y X, Effects of irrigation and nitrogen on the performance of aerobic rice in northern China, *Journal of intergrative plant biology* Volume 50 Issue 12, 2008
- [25] Feng Jianfei, Improvement of efficiency of fertilizer consumption, *Modern agricultural technology*, 2010.
- [26] Zhang Qiang, Re-estimation of direct nitrous oxide emission from agricultural soils of China via revised IPCC2006 guideline method, China agricultural university, Beijing
- [27] OECD/IEA, Cleaner coal in China, International energy agency, France, 2009
- [28] Shi Q and Zhao J, Development report of Chinese industries, Beijing, China Zhigong publishing house, 1999
- [29] Paul C and Yan W, Energy consumption in China: past trends and future directions, forthcoming in *energy economics*, Australia
- [30] L. Junfeng et al. assessment of sustainable energy potential of non-plantation biomass resources in China, *Biomass and Bioenergy* 29 (2005) 167-177
- [31] Yutaka Tonooka, Hailin Mu, Energy consumption in residential house and emission inventory of GHGs, air pollutants in China, Saitama University, Japan
- [32] Shobhakar Dhakal, Urban energy use and carbon emissions from cities in China and policy implications, Global carbon project, national institute for environmental studies, Japan
- [33] IPCC guideline-Biological waste water treatment, Volume 5_Ch 4, 2006
- [34] Wenju Jiang, Design and implement of SBR technology for wastewater from livestock farm, *Urban sewage technology*, Chemical industry publisher, 2007
- [35] The norm of energy consumption per unit product of synthetic ammonia, GB 21344-2008, 2008
- [36] Cleaner Production Standard–Nitrogenous Fertilizer Industry, Chinese Ministry of environmental protection, HJ/T 188-2006, 2006
- [37] Al Seadi T, An intergrated approach for biogas production with agricultural waste, Report on quality criteria for application of AD sludge as bio-fertilizer in agriculture, Demark, 2006
- [38] IPCC guideline—N₂O emissions from managed soils and CO₂ emission from lime and urea application, V4_11_Ch 11, 2006
- [39] Nitrogen flow and use efficiency in production and utilization of wheat, rice and maize in China, 2004

- [40] Shefali V, Anaerobic digestion of biodegradable organics in municipal solid waste, Department of Earth and Environmental Engineering in Columbia University, 2002
- [41] Introduction of Sichuan province:
http://www.izy.cn/travel_guide/4cf/13_0_0_2_0_0.html
- [42] An introduction of Inner Mongolia Autonomous Region
http://www.china-guide.de/english/a_profile_of_china/inner_mongolia/
- [43] Chinese Ministry of environmental protection, Discharge standard of pollutants for livestock and poultry breeding, GB 18596-2001, 2001
- [44] Kun Wang, Huiying Liu, Assessment of GHG emission reductions of ecological energy type and environmental protection energy type waste treatment system in large-scale pig farms, Renewable energy—Vol 27, 2009
- [45] Chinese Agricultural Ministry, Standard of irrigation water quality, GB 5084-2005, 2005
- [46] Young T, China to impose carbon tax from 2012, BusinessGreen, 12 May 2012
<http://www.businessgreen.com>.
- [47] Chinese renewable energy industries association, CDM Country Guide for China, Institute for Global Environmental Strategies 1st edition, 2005
- [48] Wu L J, Effect of different solid concentration on biogas yield and composition during anaerobic fermentation process, Int. J. Glob. Energy Issues 31(3-4), 240-250, 2009.
- [49] UNFCCC/CCNUCC, Approved consolidated baseline methodology ACM0010-‘Consolidated baseline methodology for GHG emission reductions from manure management system’, ACM0010/ Version 05 Sectoral scopes: 13 and 15, EB42
- [50] UNFCCC/CCNUCC, Approved consolidated baseline and monitoring methodology ACM0006-‘Consolidated methodology for electricity generation from biomass residues in power and heat plants’, ACM0006/Version 10.1 Sectoral scope: 01, EB55
- [51] UNFCCC/CCNUCC, Approved consolidated baseline and monitoring methodology ACM0012-‘Consolidated methodology for GHG emission reduction from waste energy recovery projects’, ACM0012/Version 03.1 Sectoral scope: 01 and 04, EB44
- [52] IPCC guideline-Energy, Vol2_1_Ch 1 introduction, 2006
- [53] A. Mirsepasi, Performance evaluation of full scale UASB reactor in treating stillage wastewater, Department of Environmental Health Engineering in University of Tehran, Iran, 2006
- [54] Fabien M, An introduction to anaerobic digestion of organic wastes, Final report in Emade Scotland, 2003
- [55] Zheng Y Y, Application of process of USR & IOD in treatment of pig farm wastewater, Environmental engineering, 2006

Appendix

Appendix 1. Reasons and expectation of biogas project development in three parts of China [13]

Region		Reasons to develop biogas project	Expect result from biogas project development
Western China	Southwest <i>Guangxi</i> <i>Chongqing</i> <i>Sichuan</i> <i>Guizhou</i> <i>Yunnan</i> <i>Tibet</i>	<ul style="list-style-type: none"> ● Ecological surrounding is extremely fragile, especially the nutrients runoff in soil; ● Weather in this region is warm and wet, fruit and crop production is high but sanitation situation is poor; ● Pesticide and fertilizer overused to protect crops from pest leads to negative environmental impact; ● Inefficient energy supplied these areas where is large reliance on firewood, straw and coal; 	<ul style="list-style-type: none"> ● Reduce further water and soil pollution from overuse fertilizer and pesticide; ● Improve the living condition and sanitation; ● Less reliance on fossil fuels; ● Economic benefit from biogas production of livestock manure in household.
	Northwest <i>Inner Mongolia</i> <i>Shaanxi</i> <i>Gansu</i> <i>Qinghai</i> <i>Xinjiang</i>	<ul style="list-style-type: none"> ● Water is rare resource in these provinces and dispersed livestock husbandry is common used; ● With increase of amount of livestock, over-grazing and desertification become quite serious. 	<ul style="list-style-type: none"> ● Control the number of livestock and regulate grazing pattern to avoid continuous desertification; ● Make use of livestock manure to produce biogas and provide energy; ● Biogas can instead of firewood to provide heat in the long cold winter not only for people but also warm greenhouse for vegetable growth.
	Others	This region consists of minority in middle and east areas. Those areas are not geographic close but similar in economic situation. All of areas contained are under-developed.	Economic benefit and make use of manure resources rather than over consumption of firewood and rice straw.
Mid & Northeast China	Southeast hill region <i>Hubei</i> <i>Hunan</i> <i>Hainan</i> <i>Jiangxi</i>	<ul style="list-style-type: none"> ● Weather in this region is typical subtropics climate; ● Sufficient livestock resources of biogas production; 	<ul style="list-style-type: none"> ● Improve the sanitation of living environment; ● Reduction of fossil fuel consumption;
	Yellow-Huai sea plain <i>Henan</i> <i>Hebei</i> <i>Anhui</i> <i>Shanxi</i>	<ul style="list-style-type: none"> ● Biggest areas of agricultural and livestock production. ● Environmental pollution results from large number of livestock breeding and overuse of fertilizer. 	<ul style="list-style-type: none"> ● Develop intensive livestock husbandry will control the waste water and manure efficiently; ● Improve the agricultural products' quality with digestate use; ● Biogas combining with greenhouse can solve the heat problem in Winter.
	Northeast <i>Liaoning</i> <i>Jilin</i>	<ul style="list-style-type: none"> ● These areas are abundant with maize and soybean which offer sufficient fodder resource for pig breed; ● Large biogas production resources and strongly reliance on fossil fuel 	<ul style="list-style-type: none"> ● Greenhouse with biogas can ensure the vegetable and fruit's sound growth condition in long cold winter; ● Saving fuels and reasonable disposal of livestock manure;

	<i>Hei Longjiang</i>	for heating provide in winter	
Eastern China	<i>Beijing</i> <i>Shanghai</i> <i>Tianjin</i> <i>Jiangsu</i> <i>Zhejiang</i> <i>Fujian</i> <i>Shandong</i> <i>Guangdong</i>	All the under-developed areas in east coast of China are included in this region. These places are inconvenience of regional transport which leads to fuels limited.	The condition for livestock production is appropriate here and great potential to develop biogas projects.

Appendix 2. Two common types of 'manure-biogas-agricultural' system

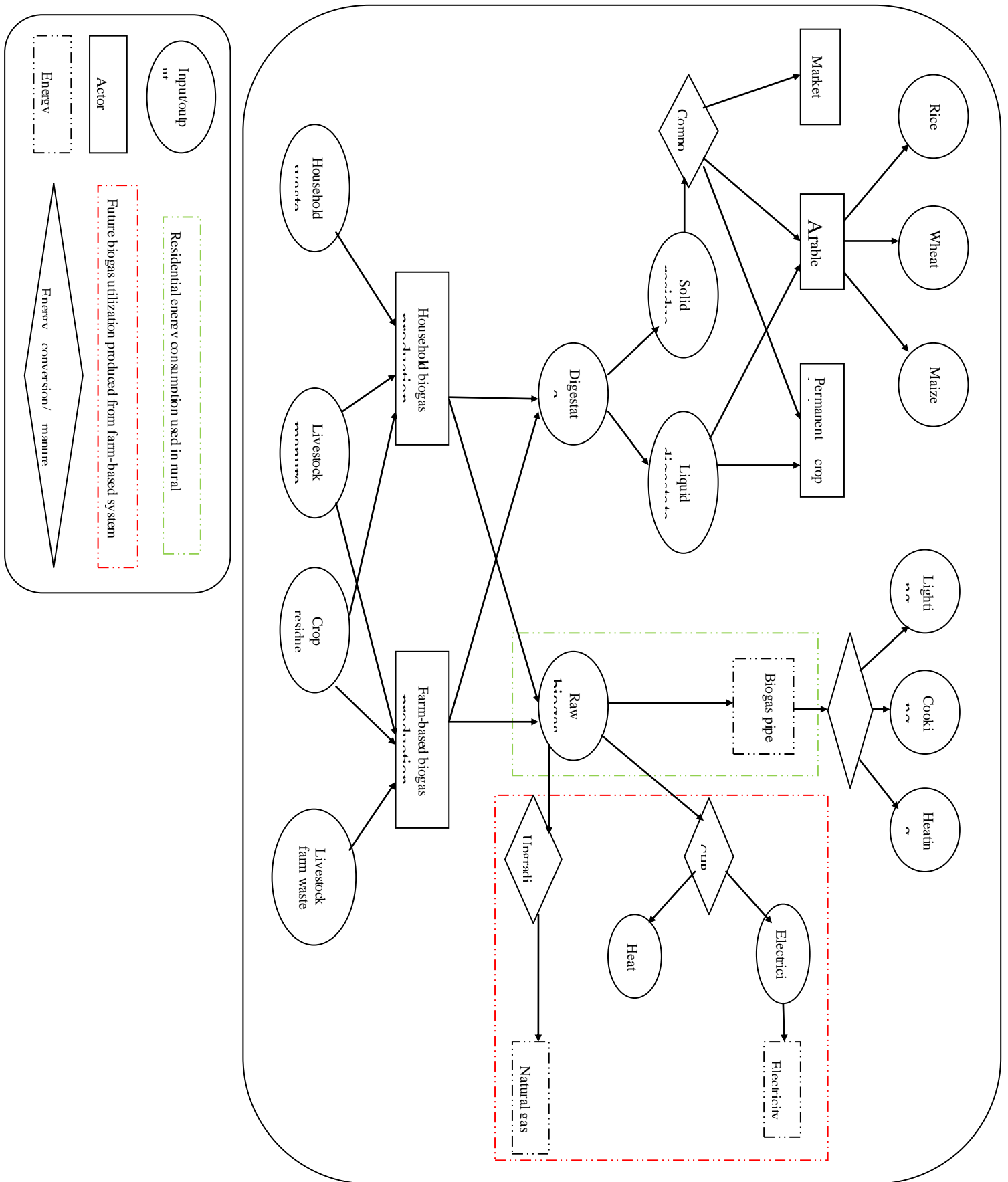

Appendix 3. GHG emission from 'manure-biogas' perspective

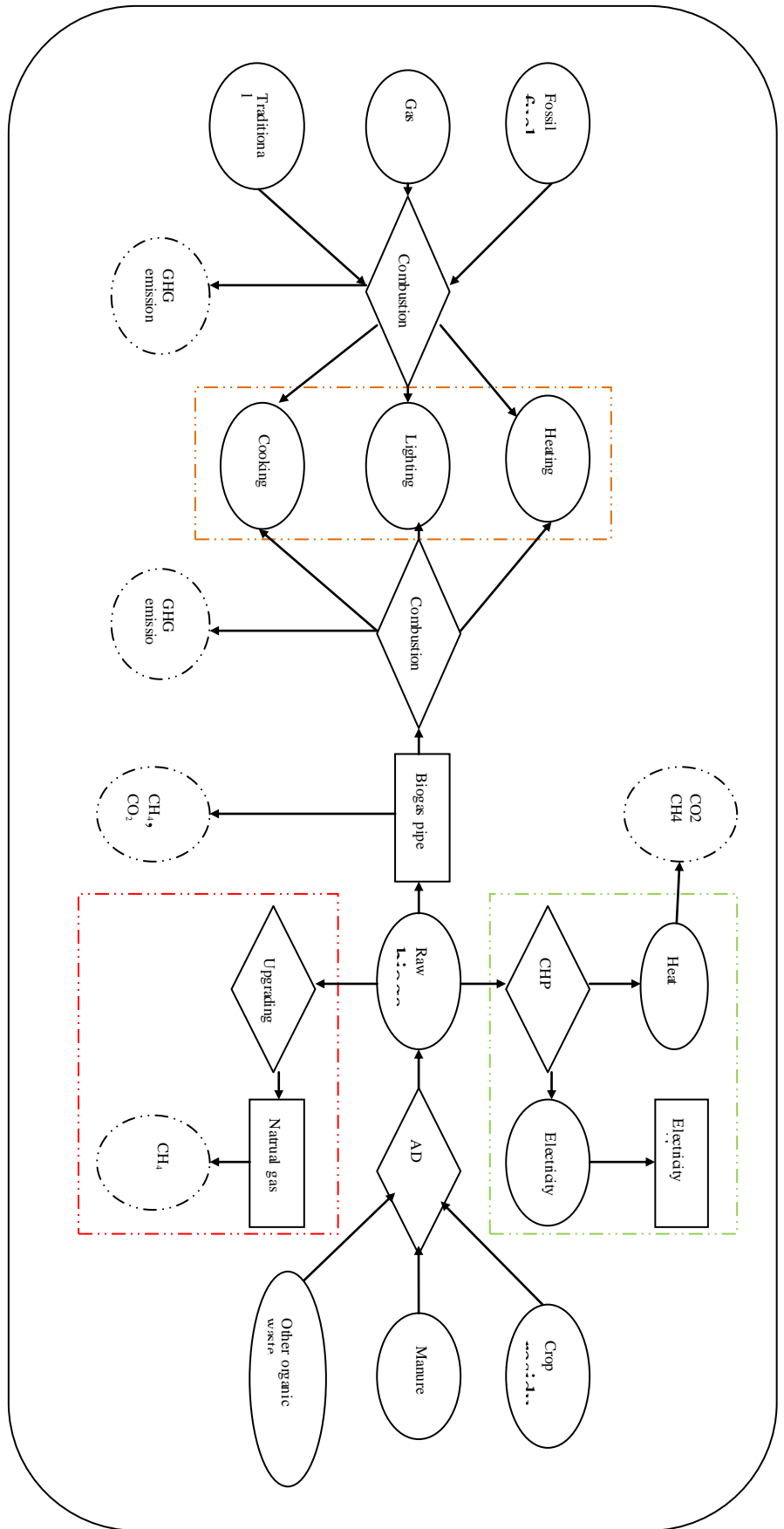
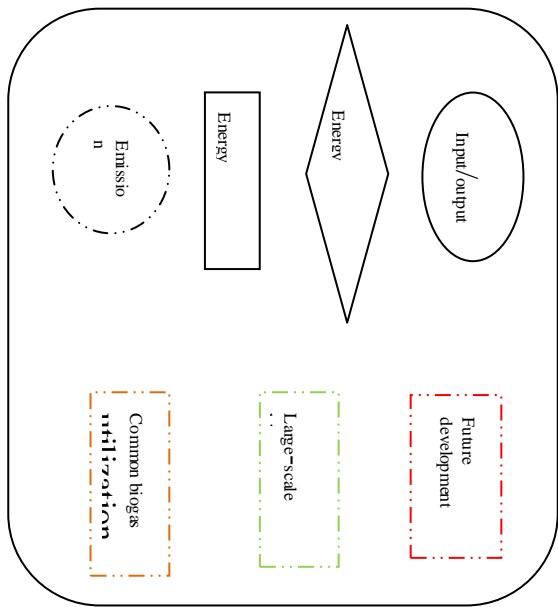

Appendix 4. GHG emission form 'manure-digestate' perspective

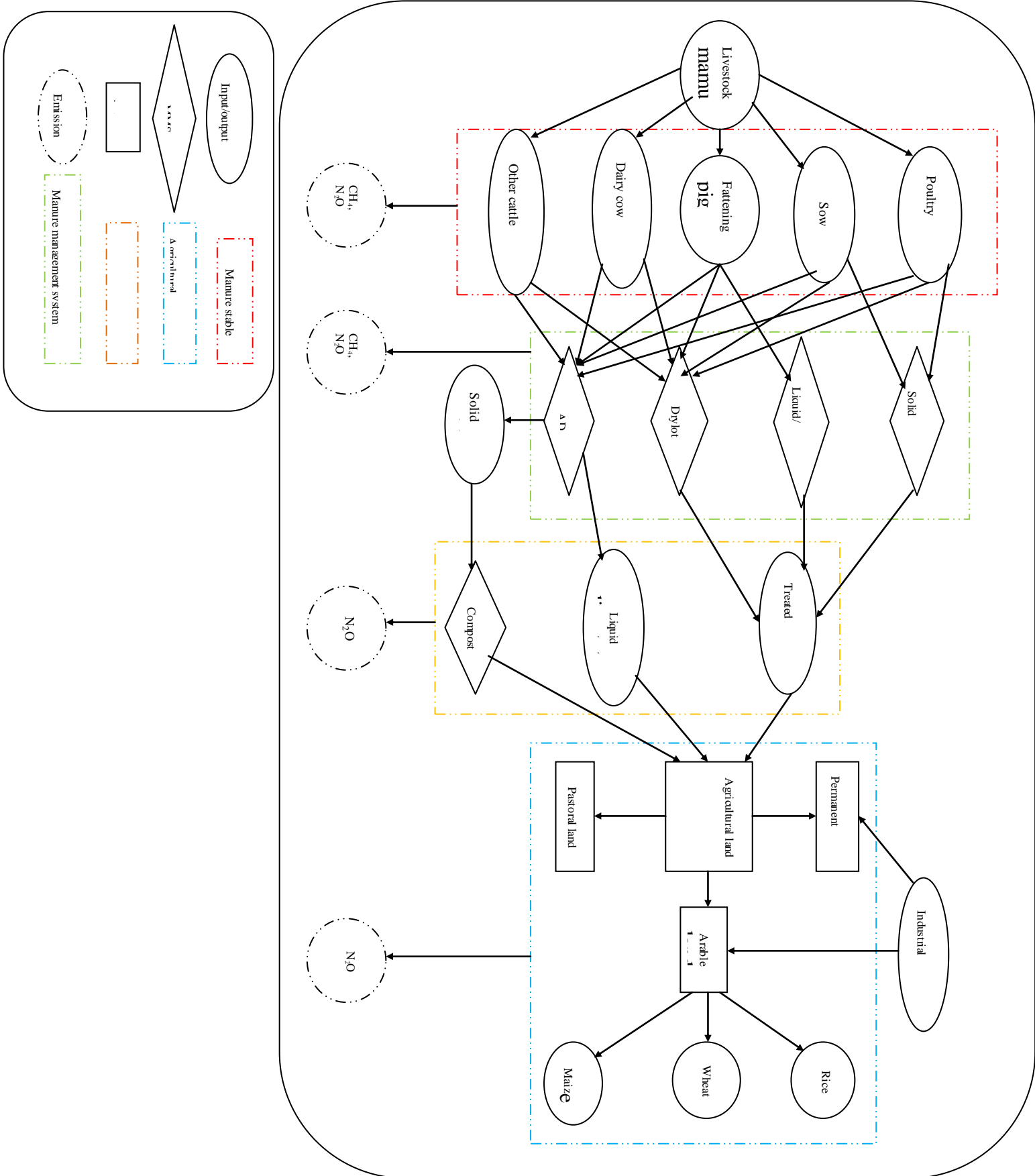

Appendix 5. Sources and pathway of N₂O emission in soil management system

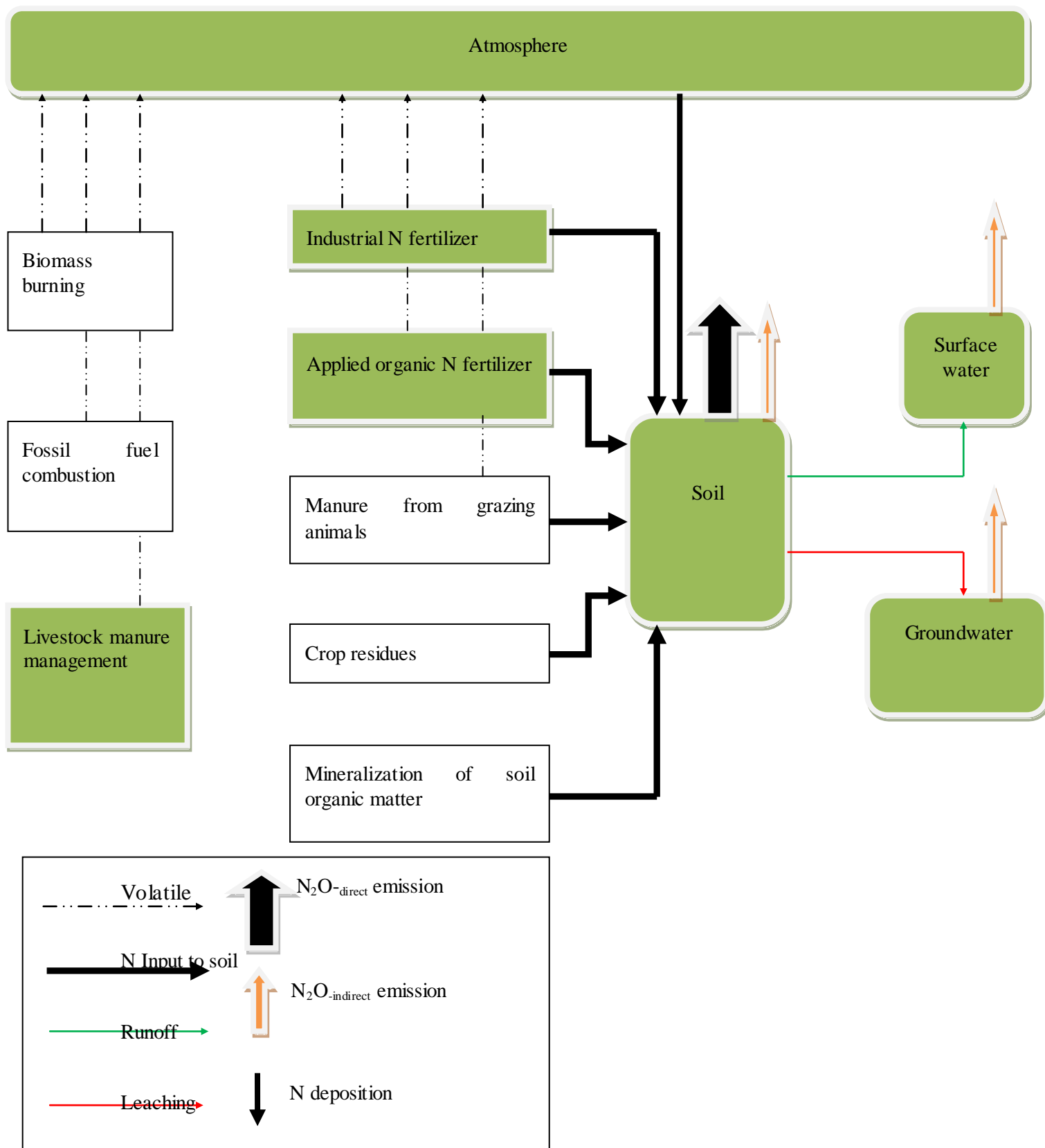

Appendix 6 Formulas for GHG emission calculation

1. ERES (emission reduction from energy substitution) and EBC (emission from biogas utilization)

$$ERES_{GHG \text{ fuel}} = FS_{\text{fuel}} * EF_{GHG \text{ fuel}}^{14}$$

2. ERMM (emission reduction from manure management) and EBP (Emission from biogas production)

Biogas system	CH ₄	N ₂ O
Rural household	$EF_{(T)}^{15} * N_{(T)}$	$[\sum[\sum(Nex_{(T)} * N_{(T)} * MS_{(T,S)}) * EF_{3(S)}] * 44/28^{16}$
M&L farm-based	$EF_{(T)} * N_{(T)}$	$[\sum[\sum(Nex_{(T)} * N_{(T)} * MS_{(T,S)}) * EF_{3(S)}] * 44/28$

3. GHG emission produced from 'manure-digestate' part of biogas systems

Biogas system	CO ₂	CH ₄	N ₂ O
Rural household	$FS_{\text{fuel}} * EF_{\text{fuel}}^{17}$ $M * EF * 44/12^{18}$	$FS_{\text{fuel}} * EF_{\text{fuel}}$	$FS_{\text{fuel}} * EF_{GHG \text{ fuel}}$ $[(F_{SN} + F_{ON} + F_{CR}) * EF_1] + [(F_{SN} + F_{ON} + F_{CR}) * EF_{1FR}] * 44/28^{19}$ $[(F_{SN} * \text{Frac}_{GASF}) + (F_{ON} + F_{PRP}) * \text{Frac}_{GASM}] * EF_4 * 44/28^{20}$ $(F_{SN} + F_{ON} + F_{CR} + F_{SOM} + F_{PRP}) * \text{Frac}_{LEACH-(H)} * EF_5 * 44/28^{21}$
M&L farm-based	$FS_{\text{fuel}} * EF_{\text{fuel}}$ $M * EF * 44/12$	$FS_{\text{fuel}} * EF_{\text{fuel}}$	$FS_{\text{fuel}} * EF_{GHG \text{ fuel}}$ $[(F_{SN} + F_{ON} + F_{CR}) * EF_1] + [(F_{SN} + F_{ON} + F_{CR}) * EF_{1FR}] * 44/28$

¹⁴ $EF_{GHG \text{ fuel}}$ is the emission factor from energy combustion part which is shown in Table a in appendix 7.

¹⁵ $EF_{(T)} = (VS_{(T)} * 365) * [B_{0(T)} * 0.67 * \sum(MCF_{s,k}/100) * MS_{(T,S,K)}]$, kg CH₄ animal⁻¹ yr⁻¹; (Appendix 7-Table b and Table c).

¹⁶ **Direct N₂O emission from MMS.** $N_{(T)}$ =number of head of livestock species in the country; $Nex_{(T)}$ =annual average N excretion per head of species in the country, kg N animal⁻¹ yr⁻¹; $MS_{(T,S)}$ =fraction of total annual nitrogen excretion for each livestock species, that is managed in manure management system S in the country. $44/28$ =conversion of N₂O-N_(mm) emission to N₂O_(mm) emission; (Appendix 7)

¹⁷ **GHG emission produced from coal combustion for synthetic ammonia production**

¹⁸ **CO₂ emission from synthetic ammonia applied on soil.** The default emission factor is 0.2 for carbon emission from synthetic ammonia applications.

¹⁹ **Direct N₂O emission from synthetic ammonia and digestate applied on soil.** F_{SN} is N fertilizer input and F_{ON} is total N organic fertilizer input. The EF_{1FR} is emission factor of paddy field, 0.41%. F_{CR} is crop residue input and EF_1 is emission factor of upland which are not considered here.

²⁰ **N₂O_(ATD) is the indirect N₂O emission produced from atmospheric deposition of N volatilized from managed soil.**

²¹ **N₂O_{(L)-N} is annual amount of N₂O-N produced from leaching and runoff of N additions to managed soils;** F_{SOM} is annual amount of N mineralized in mineral soils associated with loss of soil from soil organic matter as a result of changes to land use. The $\text{Frac}_{LEACH-(H)}$ and EF_5 are shown in Table g in Appendix 7.

			$[(F_{SN} * Fra_{CGASF}) + (F_{ON} + F_{PRP}) * Fra_{CGASM}] * EF_4 * 44/28$ $(F_{SN} + F_{ON} + F_{CR} + F_{SOM} + F_{PRP}) * Fra_{CLEACH(H)} * EF_5 * 44/28$
--	--	--	--

Appendix 7 Parameters for emission calculation of 'manure-biogas-digestate' system

Table a. GHG emission factors ($EF_{GHG\ fuel}$) for residential energy consumptions [52]

Objective	CO ₂ (g/MJ)	CH ₄ (g/MJ)	N ₂ O(g/MJ)	Combustion efficiency
Firewood	112	0.03	0.004	0.24
Coal	94.6	0.01	0.0015	0.4
Biogas	0	0.001	0.0001	0.6
NG	56.1	0.001	0.0001	0.57

Table b²² 2006 IPCC guidelines for national greenhouse gas inventories—Asia [21]

Livestock	B _{o(T)} m ³ CH ₄ kg ⁻¹ VS
pig (average)	0,29
Dairy cow	0.13

Table c 2006 IPCC guidelines for national greenhouse gas inventories—Asia [21]

Livestock	MCF of slurry/liquid system %	MCF of composting %	MCF of uncover lagoon %
swine	65	1	79
Dairy cow	65	1	79

*Temperature is estimated in 25°C

Table d²³ 2006 IPCC guidelines for national greenhouse gas inventories—Asia [21]

Livestock	EF _{3-solid}	EF _{3-Liquid}	EF _{3-composting}	EF _{3-uncovered}	EF _{3-aerobic treatment}

²² VS_(T)=daily volatile solid excreted for livestock category T, kg dry matter animal⁻¹ day⁻¹; B_{o(T)}=maximum methane producing capacity for manure produced by livestock category T, m³ CH₄ kg⁻¹ of VS excreted; MCF_{s,k}=methane conversion factors for each manure management system S by dimate region k,%; MS_(T,S,K)=fraction of livestock category T manure handled using manure managementsystem S in dimate region K, dimensionless; 0.67=conversion factor of m³ CH₄ to Kg CH₄.

²³ EF_{3(S)}= emission factor for direct N₂O emissions from manure management system S, kg N₂O-N/kg N in system S; value of liquid and slurry is 0; S = manure management system;

				lagoon	
Pig	0.005	0.005	0.01	0	0.005
Dairy cow			0.01	0	0.005

Table e²⁴ Default emission, volatilization and leaching factors for indirect soil N₂O emissions [38]

Factors	Default value
EF ₄ [N volatilization and re-deposition], kg N ₂ O-N (kg NH ₃ -N+ NO _x -N volatilized) ⁻¹	0,01
EF ₅ [leaching and runoff], kg N ₂ O-N (kg N leaching and runoff) ⁻¹	0,0075
Frac _{GASM} [volatilization from all organic N fertilizers applied, only consider livestock manure here], kg NH ₃ -N+ NO _x -N (kg N applied or deposited) ⁻¹	0,2
Frac _{GASF} [volatilization from industrial fertilizer], kg NH ₃ -N+ NO _x -N (kg N applied) ⁻¹	0,1
Frac _{LEACH-(H)}	0

²⁴ EF₄ emission factor for N₂O emissions from atmospheric deposition of N on soils and water surfaces and EF₅ emission factor for N₂O emission is from N leaching and runoff from soil. Fra_{GASF} is fraction of industrial fertilizer N that volatilize as NH₃ and NO_x; Fra_{GASM} is fraction of F_{ON} and F_{PRP} that volatilizes as NH₃ and NO_x;

Appendix 8 Biogas production process of 'energy-environmental' biogas system

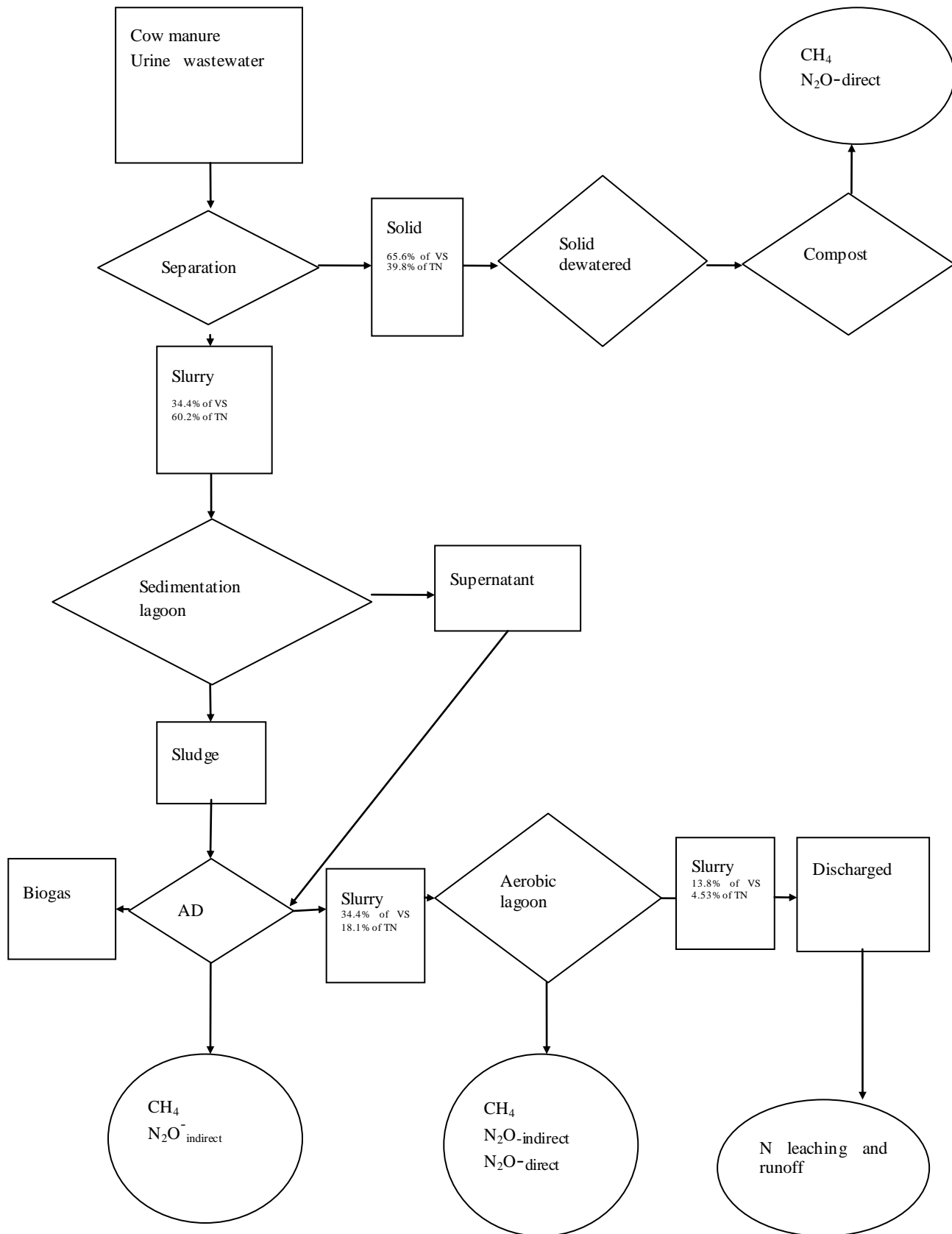

Phases in 'energy-environmental' biogas system

- Pre-treatment phase

The purpose of pre-treatment phase of 'energy-environmental' system is to remove as much as solids in feedstock by settling chamber and separation facilities. The solid separated from influent can be composted for making fertilizer. The slurry should remain in sedimentation lagoon more than one hour before entering anaerobic digester. The supernatant from sedimentation lagoon is distributed to anaerobic digester and sludge left in lagoon flows into AD for biogas production.

- Anaerobic digester selection

The AD used in 'energy-environmental' system is mesophilic fermentation which is normally no less than 15°C. UASB is the anaerobic digester mainly designed for deal with sludge concentration within 5-7 kg BOD/ m³ and its volumetric loading rate is about 10-14 kg COD/m³ during 1-12 weeks [53]. And COD removal rate ranges between 70%-85%. Compared to other anaerobic digester, UASB has three distinct zones: a sludge bed, a sludge blanket and gas separation zone [54]. The livestock manure and wastewater on farm feeds into the tank from below and flows upward through a bed of dense, granular sludge and a blanket of sludge particles. The gas-liquid-solid separation system can separate suspended solids from treated liquid and baffles are used to release trapped gas, which can promote long SRT and remain high concentration of sludge in digester to improve environmental conditions for microorganisms.

- Post-treatment phase

In 'energy-environmental' system, aerobic treatment plays the most important role in post-treatment phase. Due to high concentration of N and P in slurry flow out of digester, aerobic lagoon should be in good performance of N and P removal. SBR (sequencing batch reactor) is selected in this system. SBR system has been common used as an efficient activated sludge model for treating municipal wastewater and organic industrial wastewater with high concentration of COD and BOD₅ [34]. *Table h* represents the chemical removal rate of SBR used in post-treatment phase.

Table h The chemical removal rate of SBR in case study

Chemical categories	COD	BOD ₅	TN	TP	NH ₃ -N
Removal rate (%)	52.7 ~ 82.1	89.0 ~ 95.7	74.1	42.2	97.2 ~ 99.8

Appendix 9 Biogas production process of 'energy-ecological' biogas system

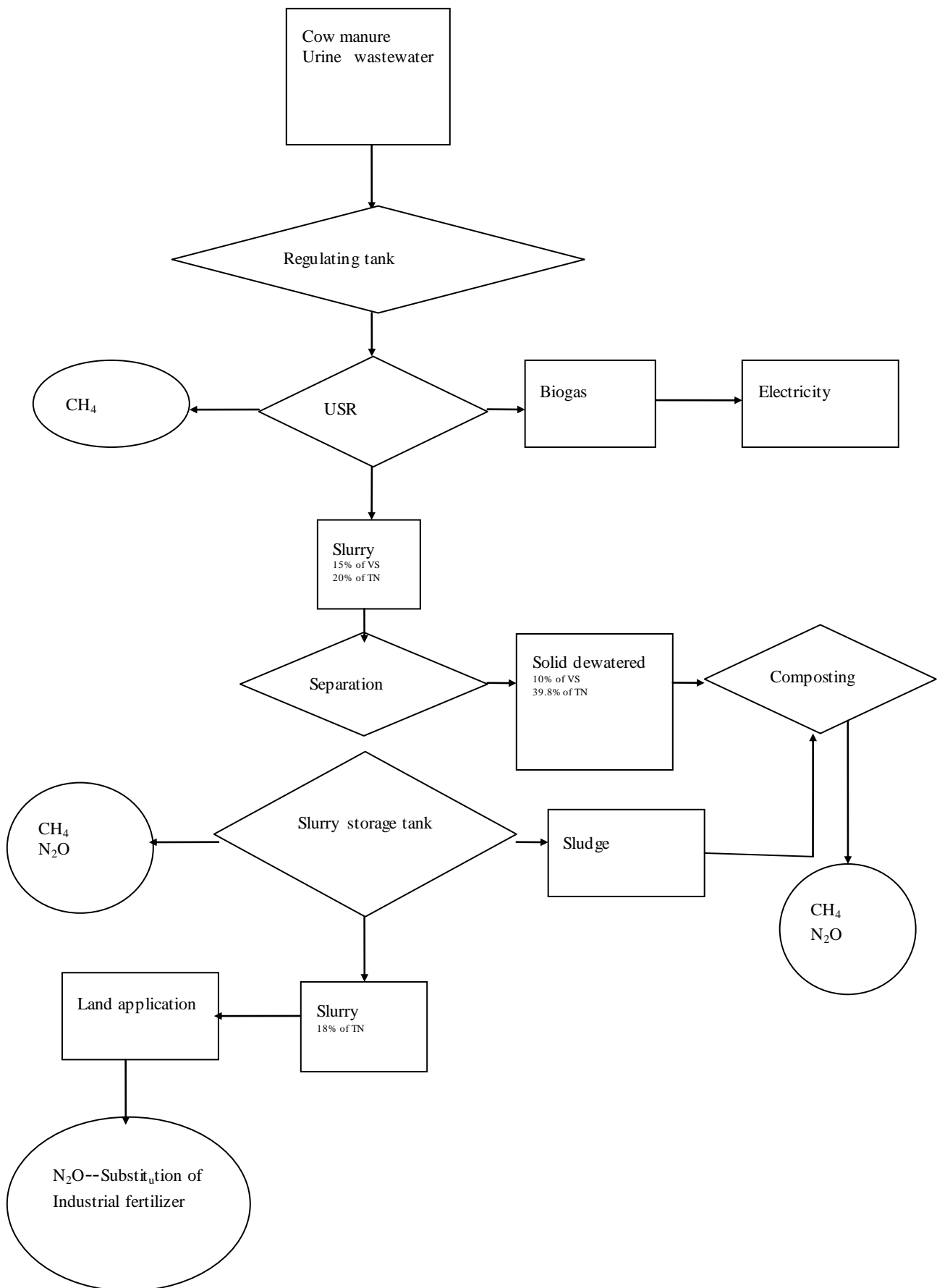

Phases in 'energy-ecological' biogas system

'Energy-ecological' system aims to produce biogas as much as possible and make use of N and P contained in digestate. The pre-condition of adopting this type of system is whether enough arable land or pastureland nearby to digest the slurry and solid residue produced from anaerobic digester. Different from 'energy-environmental' biogas system, the separation phase is taken after anaerobic digestion and all the feedstock can enter AD which will increase biogas yield.

- Pre-treatment phase

The wastewater flush on dairy cow farm is collected in water storage tank and all the manure and urine also put in. The solid with big size is removed by settling chamber before flow in anaerobic digester. However, different from liquid-solid separation facility used in 'energy-environmental' system, the chamber cannot reduce the VS content of feedstock, which doesn't have any effect to biogas yield. Regulating tank is settled before anaerobic digester, which is used for mixing wastewater and solid feedstock and regulating flow, concentration and temperature.

- Anaerobic digester selection

USR (upflow solid reactor) is a simple and low-cost anaerobic digester used commonly in China [55]. Untreated feedstock solids and microorganisms are maintained in the reactor by passive settling. The dense accumulation of solids at the bottom of digester results in long SRT. The volumetric loading rate of this digester ranges from 1.6-9.6 kg COD/m³.d. USR can remove 85% of COD.

- Post-treatment phase

Effluent from digester can be treated by solid-liquid separation facility, which removes 65.5% of VS and 39.8% of TN from effluent. The solid from separation process is put into dewatered equipment for the further composting and liquid enters to slurry storage tank. The slurry from this slurry tank with 70% of TN removal can be applied to arable land around.

To energy utilization perspective, the biogas produced from process is used for electricity production. Compared to traditional livestock farm-based project, electricity turbine can transfer biogas into electricity which can be put on national electricity grid for residents' energy consumption. Biogas through CHP has electricity efficiency about 32-38% and heat efficiency about 45% in most of Chinese project. The heat is commonly recovered for livestock farm internal demand, especially for heating anaerobic digester in winter in order to keep temperature in 25°C.

Appendix 10 The source of tables in thesis

Source of tables in text	No. table
Tables from literature	1.1, 1.2, 1.3, 1.4, 1.6, 1.7, 1.8, 1.9, 1.10, 1.13, 1.14, 1.15, 1.17, 1.18, 1.19, 2.1, 4.4 ^a , 4.4 ^b , 4.7, 4.10 ^a , 4.10 ^b , 4.14
Tables from calculation	1.11, 1.16, 3.2, 3.3, 3.4, 3.5, 3.6, 3.7, 3.8, 3.9, 3.13, 3.14, 3.15, 3.16, 3.17, 3.18, 3.19, 4.5 ^a , 4.5 ^b , 4.6 ^a , 4.6 ^b , 4.7, 4.11 ^a , 4.11 ^b
Tables from fieldwork	3.1, 3.14, 3.16, 3.2, 3.3, 3.10, 3.11, 3.12
Tables for conclusion	1.12, 4.1, 4.2, 4.3, 4.8, 4.9