

CHALMERS



3D Master Concept at Autoliv

Master of Science Thesis

SAWANGJIT WONGWANCHAI

Department of Product and Production Development
Division of Product Development
CHALMERS UNIVERSITY OF TECHNOLOGY
Gothenburg, Sweden, 2011

Master of Science Thesis

3D Master Concept at Autoliv

SAWANGJIT WONGWANCHAI

Supervised by

Professor Johan Malmqvist

Chalmers University of Technology, Gothenburg, Sweden

Magnus Dahlén

Autoliv, Vårgårda, Sweden

Examined by

Professor Johan Malmqvist

Department of Product and Production Development

Division of Product Development

CHALMERS UNIVERSITY OF TECHNOLOGY

Gothenburg, Sweden, 2011

3D Master Concept at Autoliv
SAWANGJIT WONGWANCHAI

© SAWANGJIT WONGWANCHAI, 2011

Published and distributed by
Department of Product and Production Development
Chalmers University of Technology
SE-412 96 Gothenburg, Sweden

Telephone +46 (0)31-772 1000
URL: www.chalmers.se

Printed in Sweden by
Chalmers Reproservice
Gothenburg, Sweden, 2011

Abstract

It would be great if CAD (Computer-Aided Design)-PLM (Product Lifecycle Management) users could access to complete and correct product information that they need without any limitations. This thesis is conducted for Autoliv AB. Autoliv is a worldwide, leading company that develops, manufactures, and supplies automotive safety systems. They have been implementing the PLM system since 2006.

Because product information, which exists on 2D drawings, is crucial information for the entire product lifecycle to rely on when producing a part or product, it must to be correct, consistent, and well-organized. In Autoliv's present CAD-PLM system, product information is spread in 2D drawings, 3D models, or the PLM system. This leads to information redundancies and inconsistency. In addition, it is impossible to search for the information through the PLM system since it is not soundly managed. Therefore, the 3D master concept will come to play an important role by providing master product information either on a 3D model or the PLM system, without any use of 2D drawing to solve problems and manipulate the information.

The working approach is structured into three main phases - Data collection, Analysis, and Design and Evaluation. Two main results to be delivered are requirements for changes from four main relevant functions – Engineering, Manufacturing, Supplied Quality, and Purchasing - that either create or use the information throughout the product lifecycle. The other is the suggested system solution for locating product information currently existing on 2D drawing either on 3D model or PLM, based on the formulated requirements.

Acknowledgement

This master thesis is a final part of my education in Product Development, Master of Science at Chalmers University of Technology. The six-month thesis was performed during autumn 2011 at Autoliv, Vargarda, Sweden.

The project would not have been succeeded unless there were contributions from many parties. Importantly, I owe my deepest gratitude to two of my supervisors, Magnus Dahlén at Autoliv and Professor Johan Malmqvist at the department of Product and Production Development at Chalmers for valuable knowledge, inspired discussions, guidance, and continuous supports throughout the thesis; without them the satisfied result could not have been delivered.

I would also like to sincerely thank Sigve Mörk, Andreas Carlsson, and Per-Anders Johansson at Autoliv for numerous supports and assistances in several aspects. I am grateful to Anna-Karin Persson, Daniel Lundin, Goran Helmersson, Helge Kaluza, IngaBritt Andersson, Ivan Moreno, Jonas Sterner, Lars-Erik Halenberg, and Ulla Karlsson at Autoliv for participating in the interviews and their dedication to providing me important information, materials, and feedbacks, and to Mats Sjökvist at Volvo Car Cooperation for giving the interview and the generous assistance in providing me precious information and material. Furthermore, it is my pleasure to thank to all of those not mentioned here who cooperated and contributed in any respect during the working period.

Next, I would like to give special thanks to Ananda Mahidol Foundation and FMV for sponsorship and supports throughout my master's study. It is my great honor to become a Master student under this Royal foundation. Lastly, I would like to give many thanks to my family for encouragement and endless supports during the tough time of the thesis.

Sawangjit Wongwanchai
Gothenburg, 2011

Abbreviations and Acronyms

AP	Application Protocol
AS	Autoliv Standard
BoM	Bill of Material
B-rep	Boundary-representation
CAD	Computer Aided Design
e-part	Engineering-part
EDR	Engineer Data Record
ECO	Engineering Change Order
ECR	Enterprise Change Request
FTA	Functional Tolerancing and Annotation
RD&T	Robust Design and Tolerancing
GD&T	Geometric Dimensioning and Tolerancing
IGES	Initial Graphics Exchange Specification
JT	Jupiter
LOD	Level-of-detail
MBOM	Manufacturing Bill of Material
MCO	Manufacturing Change Order
MQ	Material Quality function
PAS	Publicly Available Specification
PDM	Product Data Management
PLM	Product Lifecycle Management
PMI	Product and Manufacturing Information
PPAP	Production Part Approval Process
PRC	Product Representation Compact
SQ	Supplied Quality function

SQP	Supplier Quality Project
STEP	Standard for the Exchange of Product Model Data
STL	STereo Lithography
TCE	Teamcenter Engineering
TCVis	Teamcenter Visualization
TIFF	Tagged-Image File Format
U3D	Universal 3D
UML	Unified Modeling Language
VCC	Volvo Car Corporation
VRML	Virtual Reality Modeling Language
WIP	Work in Progress

Table of Contents

Abstract.....	i
Acknowledgement	iii
Abbreviations and Acronyms	v
Table of Contents.....	vii
Table of Figures	x
Table of Tables	xi
Chapter 1 Introduction	1
1.1 Thesis background.....	1
1.2 Autoliv company profile	2
1.3 Autoliv background.....	2
1.4 Problem analysis	2
1.5 Purposes	3
1.6 Goals.....	4
1.7 Research questions	4
1.8 Scope	4
1.9 Report outline.....	4
Chapter 2 Conceptual Framework	7
2.1 Product Lifecycle Management or PLM.....	7
2.2 Empirical company document studies.....	8
Chapter 3 Methodology	13
3.1 Working procedure.....	14
3.2 Methods and theory used.....	15
Chapter 4 Product Information in 2D Drawings.....	19
4.1 Literature studies	19
4.2 Product information existing in 2D drawings at Autoliv	19
4.3 Product information owners and users at Autoliv	23
Chapter 5 System Capabilities	25
5.1 CAD-PLM system capability studies	25
5.2 System analysis	30
Chapter 6 Requirement Definitions	31
6.1 Theory of requirement definition process	31

6.2 Implementation of requirement definition process	31
Chapter 7 Future System Design and Implementation Plan	39
7.1 Solution proposals	39
7.2 System evaluation	56
Chapter 8 Discussion	63
8.1 Reflection on the system solution	63
8.2 Implementation suggestion	63
8.3 Generalization and standardization of the suggested solution	65
Chapter 9 Future Implementation Recommendations	67
9.1 Gap analysis and recommendations	67
9.2 Further recommendations.....	68
Chapter 10 Conclusion.....	71
References.....	72
Appendix A: Interview transcription	76
Appendix A.1: Interview conclusion from information owners	76
Appendix A.2: Interview conclusion from information users.....	78
Appendix A.3: CAD-PLM case study from volvo car corporation - Interview transcription	82
Appendix A.4: Analysis of feedbacks from interviewees regarding the suggested system with users' functions	84
Appendix A.5: Analysis of suggestions from interviews regarding the suggested system with users' functions	86
Appendix A.6: Interview transcriptions of suggestions to reduce change resistance	91
Appendix B: Classification table	92
Appendix B.1: Classification of reference documents in the classification table	92
Appendix B.2: Classification table.....	93
Appendix C: The information model of the current e-part page in the PLM system	98
Appendix C.1: The first section of the information model of the current e-part page	98
Appendix C.2: The second section of the information model of the current e-part page.....	99
Appendix C.3: The third section of the information model of the current e-part page	99
Appendix C.4: The fourth section of the information model of the current e-part page	100
Appendix D: Information related to the suggested system.....	101
Appendix D.1: Document generator system candidates	101
Appendix D.2: Data exchange formats	104

Appendix E: Analysis from the Pugh matrix.....	108
Appendix E.1: The Pugh matrix of the strategy selection.	108
Appendix E.2: The first Pugh matrix is employed as a selection matrix for the 3D CAD data exchange format.....	109
Appendix E.3: The second Pugh matrix is employed as a selection matrix for the 3D CAD data exchange format.	110

Table of Figures

Figure 1: Location of product information (Information Island).....	3
Figure 2: Relationship between an e-part and CAD objects (Dahlén, 2006).....	3
Figure 3: Illustration of a general PLM system (Johannesson, 2010)	8
Figure 4: The example of a real ERP and a PLM system (Grieves, 2006).....	9
Figure 5: Relationship between an e-part revision and a CAD object revision and version (Dahlén, 2006)	9
Figure 6: Basic operation between CATIA and PLM	10
Figure 7: Relationship between ECR, ECO, and MCO in Change Management process (AutolivCAD-PLMTeam, 2006b).....	11
Figure 8: Working procedure diagram, with an activity and a result for each step.....	13
Figure 9: The relationship between product information owners and users and different types of drawings.....	20
Figure 10: The current e-part page of the PLM system.....	26
Figure 11: Information model of the current e-part page	28
Figure 12: The existing CAx-PLM environment and user roles at Autoliv	29
Figure 13: Modified information model	40
Figure 14: The product information view of General description notes.....	41
Figure 15: The product information view of Common EDR.....	41
Figure 16: The product information view of Specific EDR	42
Figure 17: Three steps of note creation process.....	42
Figure 18: Example of a part created from FTA module (DassaultSystemes, 2008b)	44
Figure 19: Activating FTA license in CATIA V5	45
Figure 20: Four steps of the process of creating a general description report.	47
Figure 21: Steps of the process of creating a Customized Drawing	49
Figure 22: An example of a customized drawing or intelligent PDF file: The CAD file of this document package originates from CATIA V5 as 3D PMI (ProSTEP, 2011).	54
Figure 23: Holistic view of suggested CAD-PLM system with its user roles.....	55
Figure 24: Overall working procedure of the suggested system.....	57
Figure 25: The components of the PDF Generator 3D (ProSTEP, 2011)	102
Figure 26: An example of a 3dvia viewer screen shot (DassaultSystem, 2011a).....	103

Table of Tables

Table 1: Engineering changes and Manufacturing changes table.....	12
Table 2: The requirement specification table of the system changes	37
Table 3: Document generator system comparison table	46
Table 4: Advantages and Disadvantages of the suggested system	64
Table 5: A possible input format for a PDF Generator 3D. Note that Tess., B-Rep, and PMI stand for Tessellated geometry, Boundary Representation, and 'Product Manufacturing Information (ProSTEP, 2011).....	103

Chapter 1

Introduction

This introduction generally provides an overview of the whole report. First, it will start with literature studies of the thesis background, the company profile, and the company background, to provide some basic ideas before the next section. After that, a problem analysis will be concluded and followed by the purpose of the thesis. Next, main research questions will be established to emphasize the major topics of the study. Then, the goal and the thesis scope will be clarified, respectively. The report outline will be presented at the end of the chapter.

1.1 Thesis background

Due to the shorter time-to-market demand and collaborative product development along with dynamically rising product complexity, such as the number of functions, reducing lead times, and getting to the market faster with efficient product quality, are competitive advantages (Wheelwright and Clark, 1992; Malmqvist, 2010c). The significant factor to achieve is to manage and control information well. Relevant information for the information consumer needs to be updated, available, accessible, and consistent (Burr et al., 2003). Furthermore, it is important that information and data is well-organized and well-managed to be able to share and communicate necessary information needed in several ways (Isaksson et al., 2000). This is because internal sources are the most important information searching sources for engineers (Chakrabarti, Feineman and Fuentesvilla, 1983). In addition, the research conducted by King, Casto and Jones (1994) reported that engineers spend 40 – 66 % of their time seeking input and sharing output via communication. According to Hertzum and Pejtersen (2000), the top five barriers for searching for written information are cost and time required, finding the right sources, risk of unavailable information, unfriendly searching tools, and abstraction of searcher's needs. Moreover, previous and current engineering projects are massive resulting in thousand times greater number of documents. As such, identifying a way to organize information for future accessibility and retrieving is necessary (McMahon, Giess and Culley, 2005). Therefore, information management provides a great possibility to allow searching for existing product information while saving time spent on communication. For the overall product development process, it leads to lead-time reduction and a saving in the cost of engineering hour.

The 3D master concept is the trend of product information representation, which is one way to manage information. In this concept, all product data is tied up to 3D models by neglecting the use of 2D drawings. The concept results from the paradigm shift in product development philosophies toward assembly-oriented design and front-loaded development, which are demanded for the overall picture of a product to save time and cost (Burr et al., 2003). In the future of the automotive industry, up to 70% of all CAD works along the product development process will rely on 3D annotated models or the 3D master concept by

accessing Digital Engineering Visualization (DEV) tools. The reason behind it is allowing non-CAD users to view and interact with all kinds of native 3D CAD data without any CAD knowledge and licenses required (Klass, 2006; Klass, 2008).

1.2 Autoliv company profile

Autoliv is the worldwide leader in developing and manufacturing automotive safety systems for various major automotive manufacturers. This requires dealing with the engineering data and information such as 3D models and drawings to a large extent. Autoliv is an early adopter in Product Lifecycle Management (PLM) implementation.

1.3 Autoliv background

Autoliv started to launch a global PLM system in 2003, and it was derived from a Product Data Management (PDM) system (Dahlén, 2006). The system was customized from Dassault Systems' Enovia PLM to suit Autoliv's business context (Weber, 2009). Presently, they are executing the second generation of the system, with demands to improve the system to the third generation in order to eliminate the existing weaknesses of the system such as inconsistency in data and to share CAD information much more closely between CAD and PLM by reducing the number of information islands either into the PLM system or a 3D model. Autoliv has a multi-CAD system environment with several legacy data to be handled. CATIA V5 is one of the major CAD systems. In this PLM-CAD system, there are two main types of objects, PDM objects and CAD objects. PDM objects consist of engineering-part (e-part) and a sketch. CAD objects include 2D data (CATDrawing (CATIA V5) or 2D drawing) and 3D data (CATProduct (CATIA V5) and CATPart (CATIA V5) or 3D model). The relationship between the e-part and CAD objects are shown in Figure 2. There are two maturities for CAD objects' status, IN WORK and COMPLETE. Generally, engineers will manage e-parts while designer will manage CAD objects. An e-part will be created after the CAD objects are in completed status, in order to have the same reference number. To have the same number as the e-part, a CATDrawing or 2D data must be generated after the e-part, and it will be saved into a plot file in PDF format (Dahlén, 2006; Butcher and Dahlén, 2004).

1.4 Problem analysis

At the moment, the problem is that the product information exchanges between PLM and CATIA, such as Geometric Dimensioning and Tolerancing (GD&T) information, annotations, and technical note texts, are limited at Autoliv. There is no information exchange among different parties through the PLM system. It is also not possible to sync the information in 2D data to PLM. Thus, searching for information located in 2D data from PLM system is restricted. In addition, product information is currently located at least one place in 2D data, 3D data or the PLM system. This leads to many problems, such as data inconsistencies, redundancies, unreliability, and data duplication.

These system weaknesses could lead to several issues, including longer product development lead time and higher development cost. This is because engineers need to spend more time on redoing work that has been completed before. They may also have changed and updated some information in only one data type although the information is located in several places

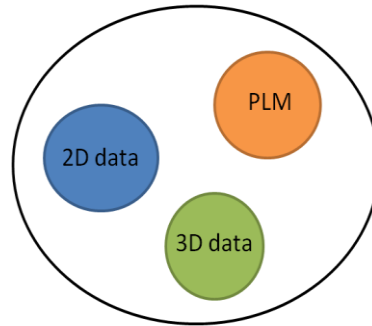

Figure 1: Location of product information (Information Island)

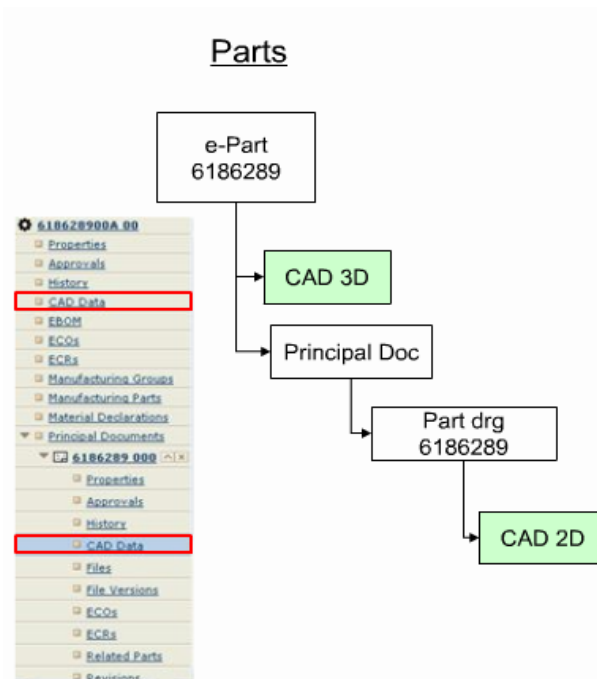

Figure 2: Relationship between an e-part and CAD objects (Dahlén, 2006)

and there is no link to update between these data locations. Furthermore, the information users need to verify the information before they use it. This takes a great deal of time. Sometimes miscommunication between upstream and downstream workers can occur due to information inconsistency and inaccuracy, thus resulting in a waste of time and money.

Hence, relocating the information from 2D drawings to fully 3D Master concepts in sync with PLM could be a good solution to managing data accurately and precisely and also to synchronizing the information in the PDM system to support the use of the information. The implementation could reduce or remove the existing problems at least to some extents while offering other advantages, such as smoothing the working process.

1.5 Purposes

The purpose of this thesis is to identify the consequences of requiring product requirements from various functions, including engineering, manufacturing, supplied quality (SQ), and purchasing, to be based either on 3D or PLM master data throughout the product lifecycle, including performing a gap study of existing solutions based on Dassault Systems' Enovia

PLM and CATIA V5. Any information existing on current 2D drawings will be relocated either to the PLM system or to 3D models as a master data since currently the information is mixed in 2D and 3D data. This master data means the main reference data in the PLM system. This information could include GD&T, material, manufacturing requirements, and so on in order to reduce consistency of data and large number of information islands into either one of two main master locations including PLM and 3D master data. Two major aims of this work are to enhance information integration and exchange more tightly between CATIA and PLM resulting in information consistency, information redundancy reduction, time and cost saving, global sharing, effective local and global collaboration, among other things.

1.6 Goals

The ultimate goal of the thesis is to provide the requirement definitions and suggested systems for the 3D master concept by using the research questions as guidance. Consequently, this work should also deliver product information existing on current 2D drawings and its owners and users, existing system capabilities, requirements for the changes, the suggested system (including proposed information model of modified parts), some system users' views screenshots, CAD solution suggestions, future users' roles, 2D drawing replacement solutions, gap analysis, and recommendations.

1.7 Research questions

- What information is in Autoliv drawings?
- Who are the owners and the users of the information found in the drawings?
- What are requirement definitions for changes?
- How should product information in 2D drawing be relocated into PLM?
- How should product information in 2D drawing be relocated into CATIA?
- How should information from PLM and CATIA be gathered together?

1.8 Scope

The scope of this thesis work is to suggest the requirements for and a solution to moving product information in 2D data to be located in either 3D data or the PLM system, while still fulfilling the identified needs and requirements from various related functions who create or use the information throughout the product lifecycle. It is also to perform a gap study between an existing system and a suggested solution based on CATIA V5 and Dassault Systems' Enovia PLM. The 2D data or 2D drawing in this thesis only refers to product drawings that consist of component and assembly drawings. The ideal goal is to implement this result globally. However, for the most part, all information needs and requirements was collected and identified locally at Autoliv in Vårgårda, Sweden.

1.9 Report outline

The report will be divided into ten chapters. The next part is about the conceptual framework described in Chapter 2. Then, Chapter 3 will describe the procedures of thesis and the methods used in this thesis. It will be followed by Chapter 4, which provides details about product information in 2D drawings at Autoliv. Next, Chapter 5 presents current CAD and PLM system capabilities at Autoliv. After that, requirements will be formulated in Chapter 6.

The suggested system is introduced in the Chapter 7, which covers all required solutions for system changes. Next, discussions will be provided in the Chapter 8, and recommendations for future implementation will be discussed in Chapter 9. Finally, the closure and summary of the works will be concluded in Chapter 10.

Chapter 2

Conceptual Framework

This chapter provides the theoretical background of the thesis and general concepts needed to have a better understanding of the contents of the thesis, before moving on to the next chapter. Most literature here originates from the company documents since Autoliv is the focused analysis context.

2.1 Product Lifecycle Management or PLM

A PLM system is analogous to an ERP or Enterprise Resource Planning system. However, they focus on different aspects as follows. PLM systems emphasize information and knowledge related to product domain throughout the product lifecycle including the product development process, the production phase, the sale phase, and the after sale phase. On the other hand, ERP systems stress on the knowledge of organization domains particularly involved with the production phase, the sale phase, and the after sale phase. The main concerns are an information transaction related to the product, the customer, the supplier, and the employer and an information tracking associated with a production until the delivery of the end-product (Grieves, 2006). Several PLM definitions were given by several people and organizations from different industries. The most common one is from CIMdata. It states as follows: *“PLM is a strategic business approach that applies a consistent set of business solutions that support the collaborative creation, management, dissemination, and use of product definition information, supporting the extended enterprise (customers, design and supply partners, etc.), spanning from concept to end of life of a product or plant, and integrating people, processes, business systems, and information”* – Quoted from CIMdata (CIMdata, 2011). In short, PLM, an information-driven approach, is an integration of business processes to manage information regarding a product throughout its lifecycle.

Three major roles of a typical PLM system given by CIMdata are: providing security controls of any accesses and uses of information in the system, maintaining the integrity of the information throughout the product life, and managing business processes in creating, manipulating, distributing, sharing and using the information (CIMdata, 2011).

The principal functions or sub-modules of a commercial PLM system should contain at least the following: avoiding information loss during updating, backup management, change management, configuration management, document management, document status including version and revision maintenance, electronic vault of file, history/system log, information retrieval, item management, product structure management and maintenance, user privilege management, and workflow management (Saaksvouri and Immonen, 2005).

The illustration of a general PLM system is provided in Figure 3. There are three main pieces of the system. The first element is the Product Lifecycle which consists of several activities related to a product starting from the Product planning stage until Disposal and Recycling state Next, the second piece is engineering tools such as a Computer Aided Design (CAD)

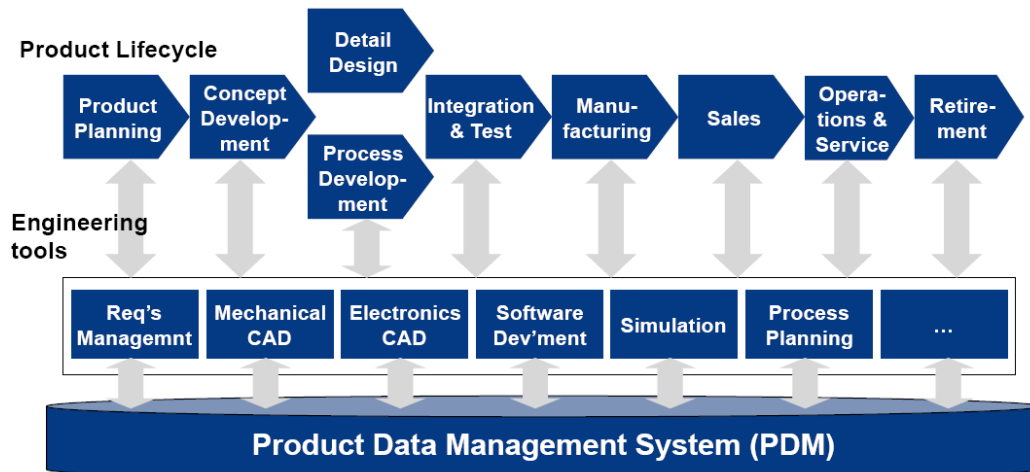

Figure 3: Illustration of a general PLM system (Johannesson, 2010)

system, which supports the product lifecycle activities by, among other things creating, simulating, and analyzing information and data. Finally, the last piece is a PDM or Product Data Management system. It stores, organizes, distributes, and controls the information and data associated with the product throughout its lifecycle. Although the information and data is created by some activity or some function, it is available for all the users in the product lifecycle (Grieves, 2006; Johannesson, 2010). An example of real ERP and PLM systems at the Jet Propulsion Laboratory's (JPL), Pasadena, CA is provided in Figure 4.

2.1.1 Autoliv's PLM system

Autoliv's PLM system is based on ENOVIA MatrixOne from Dassault systems. MatrixOne is a PLM system specialist company taken over by Dassault systems in 2006. The name was changed to ENOVIA MatrixOne. (Wikipedia, 2010a). The ENOVIA MatrixOne PLM system at Autoliv was customized and developed in-house to suit the business needs and processes by an internal development team and external expertise consultants.

Autoliv also creates the PLMwiki page, the internal, useful encyclopedia accessible through the Autoliv global intranet. The information found on the page, mostly for the CAD-PLM users, is related to PLM and CAD contents and their updates. More information about Autoliv's PLM system is also available on the PLMwiki page.

2.2 Empirical company document studies

This section is intended to describe some parts and concepts in CAD-PLM system that are correlated to the thesis area.

2.2.1 Version and revision

A revision is a distinct design of a CAD Version. Meanwhile, a version is the revision iteration. A new revision will be created at the request of the user. A revision can have as many versions as possible. A version is Work in Progress (WIP) data created at Check In that maintains the history of how a particular revision evolved. All parts/assemblies or drawings in one assembly do not need to have the same version and revision number (Dahlén, 2006; AutolivCAD-PLMTeam, 2006a). 2D data in a globally supported Autoliv plot format must be

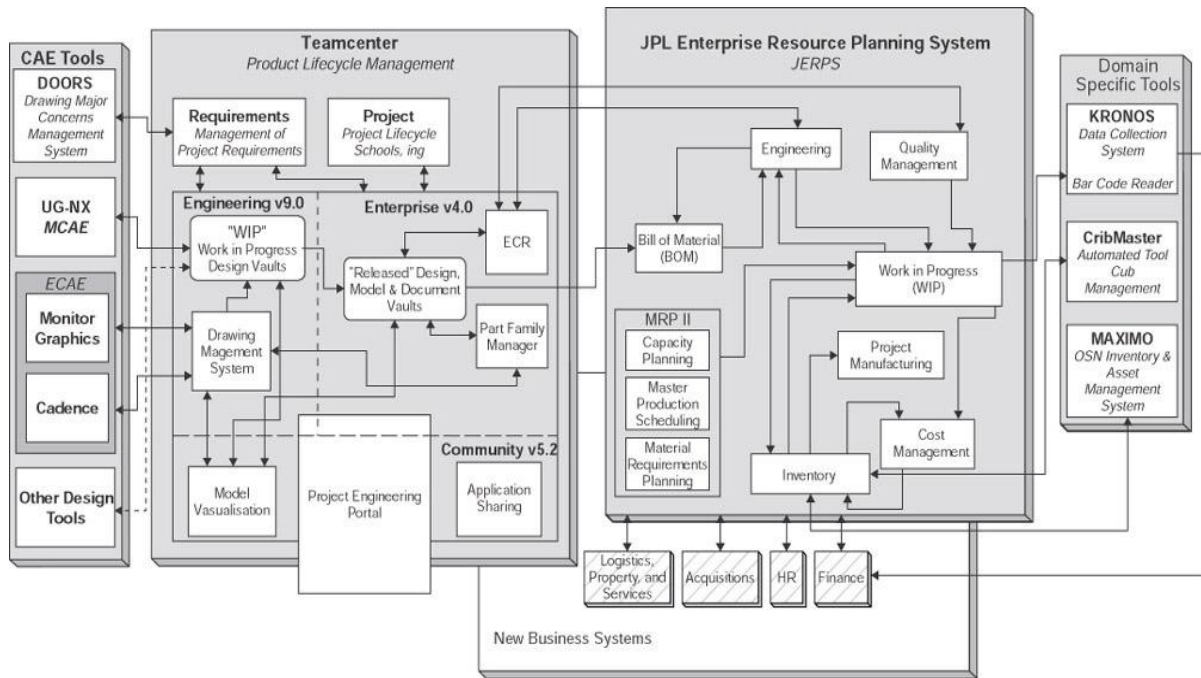

Figure 4: The example of a real ERP and a PLM system (Grieves, 2006)

available to view and print for all CAD data checked into PDM (Butcher and Dahlén, 2004). The relationship between version and revision of an e-part and a CAD object is depicted in Figure 5. The information about principal document number is specified below (Appleby and Dahlén, 2006).

- The principal document number format (IXXXXXX NNN) is built up from the following component.
- IXXXXXX = Principal Document Number, which is automatically assigned by the PLM system from the same series as the base number of an Engineering part since they share this base number.
- NNN = Principal document revision number, which is numerical only and progresses for every document change, starts from 000 and is never reset back to 000. It is also automatically assigned (AutolivCAD-PLMTeam, 2009b).

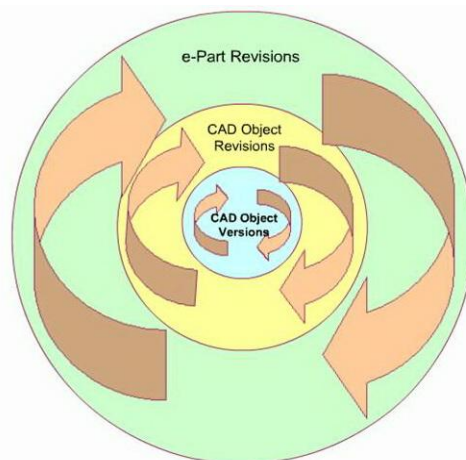

Figure 5: Relationship between an e-part revision and a CAD object revision and version (Dahlén, 2006)

2.2.2 The general concepts of the current CAD-PLM (AutolivCAD-PLMTeam, 2006a; AutolivCAD-PLMTeam, 2009)

- File names will only be a number.
- Revision and Title will be separate CAD Object attributes.
- The Designer can pull new Part Numbers.
- CAD object revisions are independent of the e-part and Part Drawing revision.

2.2.3 Basic operation between CATIA and PLM

When CAD is checked out from PLM, they are downloaded to the local model directory before being opened into CATIA. However, when they are closed from CATIA, the documents still remain in the local directory (AutolivCAD-PLMTeam, 2009; AutolivCAD-PLMTeam, 2009b). The operation is shown in Figure 6.

2.2.4 Change management

Change management is managing any change orders in the PLM system. The change management process is the process of requesting, determining the attainability of, planning, implementing and evaluating changes in a system. The main purpose is to make the changes fast, complete, and correct, and to avoid any duplication (Malmqvist, 2010a). According to Autoliv, there are Enterprise Change Request (ECR), Engineering Change Order (ECO), and Manufacturing Change Order (MCO) in the change management process as mentioned below (AutolivCAD-PLMTeam, 2006b; AutolivCAD-PLMTeam, 2008) The relationship between ECR, ECO, and MCO is illustrated in Figure 7.

- ECR handles feasibility studies and approvals for any kind of changes. This process is accomplished separately from ECO and MCO. One ECR can contain more than one ECO/MCO.
- ECO is the tool used to work through the release of Engineering Parts and Part Drawings. The ECO is auto-created on the Approval of an ECR. In addition, the ECO controls the release of parts and drawings by sending out review tasks to the responsible party for approvals and promotions. Also notification tasks are sent out by the system for parties that do not have to take an active part in the release process but only need status information about the parts/drawings. There are 4 stages in ECO: Create, In-work, Complete, and Cancelled. The ECO is always owned by an Engineering Team.

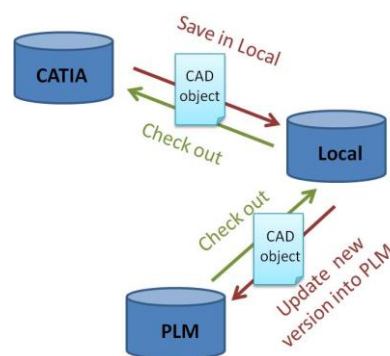

Figure 6: Basic operation between CATIA and PLM

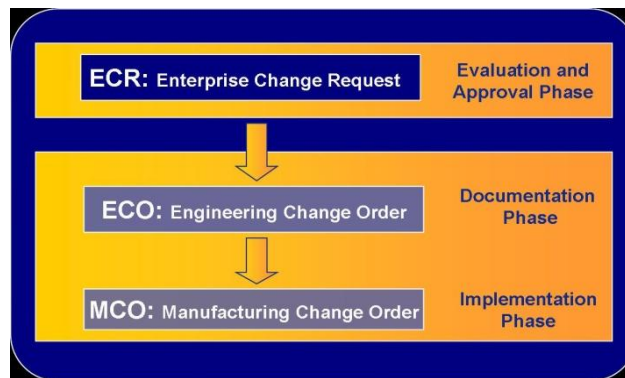

Figure 7: Relationship between ECR, ECO, and MCO in Change Management process (AutolivCAD-PLMTeam, 2006b)

- MCOs are the vehicle utilized for managing the documentation and implementation in manufacturing plants as well as the coordination with Logistics. The release of M-part controlled by MCO. The MCO is closed when the change is implemented in a production. The MCO is always owned by a Manufacturing Team.

There are two main cases in the change management processes (AutolivCAD-PLMTeam, 2006b; AutolivCAD-PLMTeam, 2008).

- **Multiple changes affecting the same product:** It is often that a part is changed by different people at the same time resulting in too many updated revisions in the system. There are two common functions here, combining ECOs and splitting ECOs. First, the ECO combining function could be useful to allow the system to have only one new revision. More than two parallel ECOs can be merged into one single ECO. When combining, however, different ECOs must have the same design authority and they are in “Create state.” Second, ECO splitting would be utilized in cases of more than one part. Furthermore, drawing ECO connected should not be implemented at the same time, but in sequence. MCO can be combined as well.
- **Skip to implement a change in production:** In some situations, any subsequent changes need to wait for a certain configuration to be confirmed from the manufacturing side. This leads to sequence of an e-part revision that will not directly connect to an m-part revision. The cancellation of ECO/MCO is also possible. After the ECO and MCO are generated, they will be in “in-work” status until the owner of the changes decides either to implement or not implement. In the later case, MCO will be cancelled.

2.2.5 Change management process

There are five general steps in a change management process (AutolivCAD-PLMTeam, 2006b). They are the following:

- **Create:** The ECR is created by a person who has an idea or a problem.
- **Submit:** The change is evaluated by local teams. Further configuration of the ECR is done and recommendations for the CCB are given to suit a local feasibility.

- **Evaluate:** The change is evaluated by additional teams and functions and recommendations for the CCB are given to suit a global feasibility.
- **Review:** The ECR is reviewed by the CCB and a final decision about the change is made. There are three possible decisions: implementation as a change, implementation as an eAPDS project and disapproval of the ECR.
- **Approved or Disapproved:** If the ECR is approved, then change orders are created. If the ECR is disapproved, it cannot be activated any more.

2.2.6 ECR change types

Engineering change is a change in an e-part and engineering documents; it often affects form, fit, function or performance of the part. Another change is a manufacturing change which is a change in a m-Part or to the production process of an M-Part (AutolivCAD-PLMTeam, 2006b). The changed details of both changes are stated in Table 1. In this thesis, only engineering changes will be considered.

Engineering changes include	Manufacturing changes include
Create	Create
Design Change obsolete previous level	M-BOM change interchangeable
Design Change not obsolete previous level	Component process change
E-BOM Change interchangeable	M-BOM variation
E-BOM Change non-interchangeable obsoletes	Change of manufacturing process
E-BOM Change non-interchangeable not obsolete	Move of line (in the same plant)
Obsolete	Obsolete
Specification content change	

Table 1: Engineering changes and Manufacturing changes table

Chapter 3

Methodology

This chapter will describe the working procedure and methodology used when conducting this study. The tools and methods used during the entire thesis will be identified here in details.

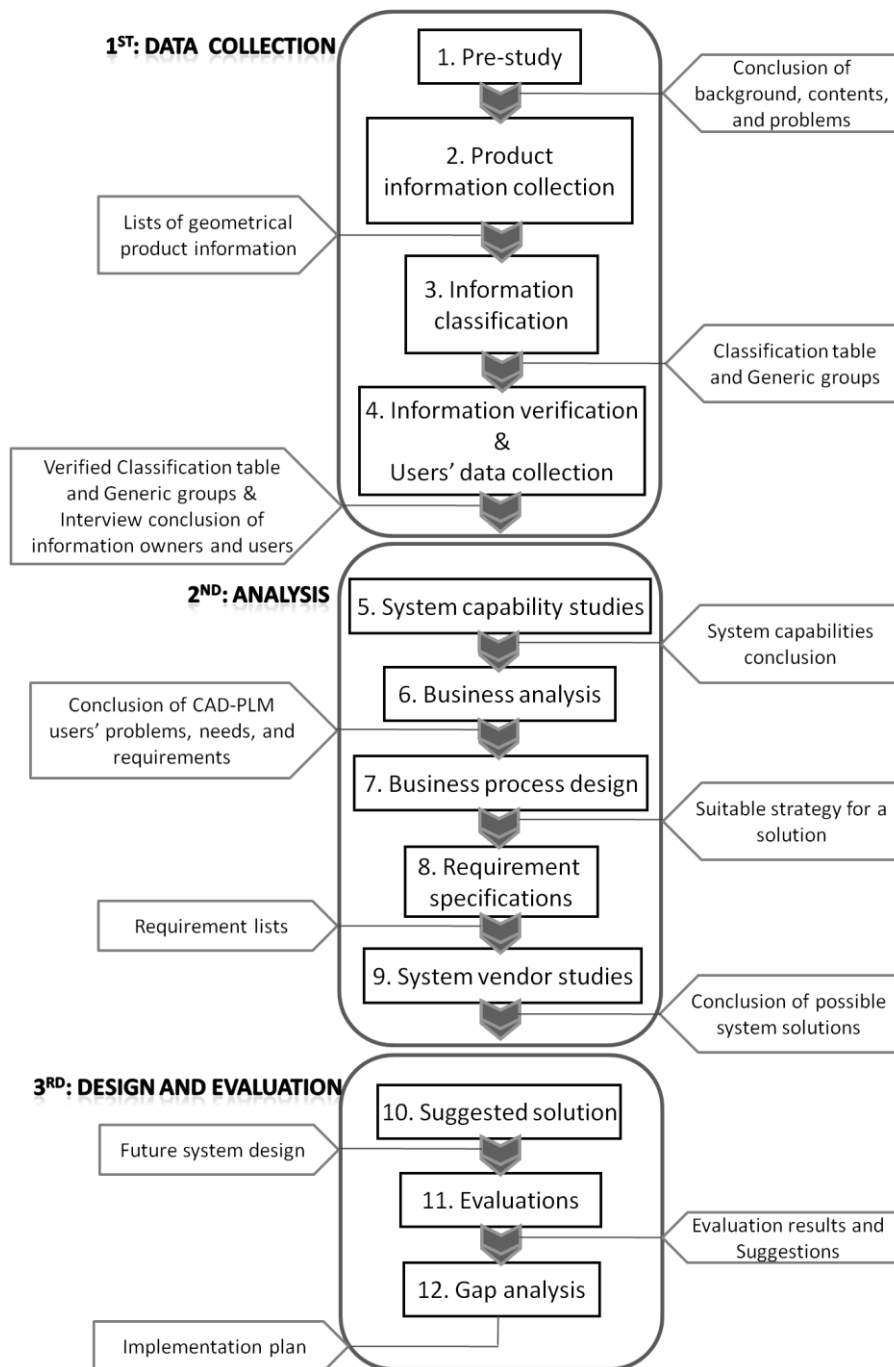

Figure 8: Working procedure diagram, with an activity and a result for each step

3.1 Working procedure

The working procedure was divided into twelve steps and grouped into three main phases as shown in Figure 8.

3.1.1 First phase: Data collection

- Pre-study
 - Methods: Searching and studying the company's documents and literature studies.
 - Purposes: To clarify the thesis background, contents, and problems.
- Product information collection
 - Methods: Searching and studying literatures and collecting the company's product drawings and note templates.
 - Purposes: To define product information on 2D drawings.
- Information classification
 - Methods: Analyzing the previous information collection by using the KJ-Shiba method.
 - Purposes: To classify the collected product information from 2D drawings and to formulate generic groups that represent the similar kind of information.
- Information verification and Users' data collection
 - Methods: Interviewing information owners and users, comparing the classification with the STEP standard, and participating the PLM trainings of the company.
 - Purposes: To verify the previous information collection and classification, fulfilling the missing information, to collect the information owners' and users' needs and wishes, and to define the information owners and users.

3.1.2 Second phase: Analysis

- System capability studies
 - Methods: Searching for and studying on the company's documents, interviewing and participating the PLM training.
 - Purposes: To identify the current system capability for the use of future analysis.
- Business analysis
 - Methods: Analyzing the previous interviews, system capability studies, and some additional company documents.
 - Purposes: To conclude problems in the system identified in previous steps and define needs and requirements of product information users and owners for further analysis in the following step.
- Business process redesign
 - Methods: Using analysis from the previous step to generate implementation strategies for a solution and utilizing the Pugh matrix for strategy selections.
 - Purposes: To select the most suitable strategy for a proposed solution.
- Requirement specification
 - Methods: Studying literature as a guidance and using previous collected and analyzed information to set up the requirements.
 - Purposes: To formulate a requirement definition table.

- System vendor studies
 - Methods: Searching for and studying literatures and the possible system solution from vendors' documents, and consulting an expert for further information.
 - Purposes: To find system solutions provided on the market for further analysis in the next step.

3.1.3 Third phase: Design and Evaluation

- Suggested solution
 - Methods: Analyzing and optimizing the previous data. The Pugh matrix and comparison table were used during the solution analysis.
 - Purposes: To suggest the optimal solution.
- System evaluation
 - Methods: Benchmarking and interviewing.
 - Purposes: To reflect on the current proposed system solution as suggestions for recommendations.
- Gap analysis
 - Methods: Analyzing the current system compared to the purposed system.
 - Purposes: To provide the gap study for Autoliv as an implementation plan to achieve the proposed solution.

3.2 Methods and theory used

Several tools for data collection, analysis, and design are available. However, it is important to use suitable tools for the situation. The following lists are methods used during the study mentioned previously in working procedure.

3.2.1 Interviews

An interview is a popular research tool for data collection or a primary approach in a study. The interview structure affects the depth of the response. There are three kinds of interviews: Fully structured (Arranged fixed questions); Semi-structured (Prepares predefined question with possibility to change depending on interview situation); and Unstructured (Sets only scope of interviews) (Robson, 2002). Individual interview should be conducted for a period of one to two hours (Ulrich and Eppinger, 2008).

There are in total four types of individual interviews in this study, which were conducted for different purposes. Each was audio recorded and had been transcribed later after the interview to receive complete information. The first interview was conducted over several rounds with nine interviewees to collect the system users' data. The second interview was performed once with one participant for the purpose of PLM system clarification. The third interview was similar to the second one, except its intention was to collect case study information for benchmarking. The last interview was to identify users' feedbacks for the system evaluation purpose.

- The first Interview
 - Purposes:

- To validate and confirm the product information on 2D drawings that have been collected and classified to enable continued developing toward a solution and also to verify Generic groups, the group of information classification.
 - To define the information owners and users and know exactly how people create and use the information.
 - To identify needs and problems connected with using 2D drawings and 3D models.
 - Duration of each interview: One and a half to two hours.
 - Structure: Semi-structured interview.
 - Interviewee's characteristic: Each interviewee is a representative from each function that is involved with product information at Autoliv. If the collected data is then unsaturated from a representative's function, an interview will be conducted with other representatives from that function until the data is saturated. Below are the roles of each interviewee, from the first interview to the last, in that order.
 1. Seatbelt senior design engineer: He was interviewed twice to fulfill any missing information.
 2. Airbag design engineer.
 3. Manufacturing : Process engineer.
 4. The first Supplier quality engineer.
 5. Purchasing: Project buyer.
 6. Manufacturing: The first Manufacturing quality engineer.
 7. The second Supplier quality engineer.
 8. Manufacturing: The second and third Manufacturing quality engineers.
- The second Interview
 - Purposes: To clarify and identify in details of an e-part in the PLM system.
 - Duration of each interview: two hours.
 - Structure: Structured interview.
 - Interviewee's characteristic: PLM coordinator at Autoliv.
- The third Interview
 - Purposes: For Volvo Car Corporation (VCC) case study as a reference for benchmarking.
 - Duration of each interview: two hours.
 - Structure: Semi-structured interview.
 - Interviewee's characteristic: CAD-PLM coordinator at VCC.
- The fourth Interview
 - Purposes: To receive CAD-PLM users' feedbacks on the suggested solutions.
 - Duration of each interview: 45 minutes.
 - Structure: Unstructured interview.
 - Interviewee's characteristic: The same group as the first interview. Interviewee number 1 to 5 and 8 in the first interview participated.

3.2.2 PLM trainings

Observing the product in-use and gaining firsthand experience can be counted as the one of the best methods for data collection. This is because it can reveal important details about customer needs and clarify users' problems and needs to the researcher (Ulrich and Eppinger, 2008). In CAD-PLM systems, the most appropriate way to observe the users is to attend their training. The aim of the attendance is to gather deeper details about the working procedures of CAD-PLM users and to understand the problems by one's own experience. It is used as a method in information verification and users' data collection steps. Training duration is three and a half hours. The training includes:

- Basic PLM training: The basic PLM training is the overview of the PLM system.
- Engineering PLM training: The content is related to the uses of PLM for engineers.
- Manufacturing PLM training: It is the utilization of the PLM system for manufacturing people.

3.2.3 Affinity diagram or KJ-Shiba method

The affinity diagram or KJ-Shiba method is one of the potential analysis methods that can be used to organize a large number of information according to the natural relationships within the information. The principle idea is to group the similar information together. The tool is used in Chapters 4 and 6 to group collected product information. The method can be accomplished in six steps, which are arranged in sequence as follows (Alange, 2009; Bergman and Klefsjo, 2010):

- STEP 1: Formulate the major question or define a main subject for the analysis as an objective for data collection.
- STEP 2: Collect the information that could answer the stated question and writing each on a small paper or post-it note.
- STEP 3: Clarify the definition of the collected information.
- STEP 4: Perform the first level grouping by grouping the similar collected information and then give a short headline for each first level group. If some information does not associate to others, it is common to place it in a new separate group.
- STEP 5: Continue grouping by clustering each related previous short headline from the first level grouping together and naming a new headline for each second level group. After that, the procedure is optionally repeated to form the third, fourth, and higher of groups under new headlines to create hierarchy. It depends on the complexity of the information.
- STEP 6: The arrow could be used to show connections among the groups before making the final evaluation of grouping.

3.2.4 The Pugh matrix

The Pugh matrix is a selection matrix used to narrow down the concept quickly by comparing several concepts with a reference concept and selecting one or few concepts to continue development. The Pugh matrix will be implemented in Chapters 6 and 7. The selection process consists of six steps stating in the following paragraphs (Ulrich and Eppinger, 2008; Johannesson, 2010).

- STEP 1: Provide candidate concepts and prepare selection criteria based on the wishes and demands of an organization and its customers before putting them into the selection matrix. It is important that the number of criteria is not greater than 20 criteria and the set of criteria should be able to differentiate among the concepts.
- STEP 2: Assign a weighting factor to each criterion to judge consistently and provide the reasonable result in the case that all criteria are not equally important. This is an optional step.
- STEP 3: Set a reference concept or a datum in order to compare other concepts to it. The reference could be the best practice concept at that time, a straightforward concept, commercially available product early generation concept, and industry standard concept.
- STEP 4: Rate each concept to the datum by giving relative score of better than (+), same as (0), or worse than (-) to concepts in all stated criteria without any bias.
- STEP 5: Calculate the relative score of each concept by summing relative scores for no weighting factor or multiplying a relative score to a weighting factor of each criterion before defining a total score for available weighting factors. The total score of the datum will be zero.
- STEP 6: Finally, rank all concepts including the datum from highest score to lowest score. Then, one or more concepts will be chosen for continuing development or further refinements and analysis. Note that the six steps of this analysis could be done repeatedly to select the best concept.

3.2.5 Benchmarking

The general meaning of benchmarking is to compare a business process and performance of one firm with the best practices of a company in the same industry that is mostly often a competitor for the purpose of improvement and achieving competitive advantages (Wikipedia, 2011a). Benchmarking also means the study of existing products in the market or under development with similar functionality or analogous problems. The purpose of benchmarking is to find out the best solution or any stronger points of competitive products to improve one's existing product and solve its problems. Searching for similar products is a key to achieving this method (Ulrich and Eppinger, 2008). In this thesis, benchmarking will be a tool for defining missing potential functions of the suggested system for the 3D master concept in order to improve the system by evaluating it against the existing implemented systems from other firms.

3.2.6 Unified Modeling Language or UML class diagram

To create an information model, a standard language list of objects to be stored in a database is required. There are three common information modeling methods: the Entity-Relationship Model, UML class diagram, and Express. However, only UML will be explained. UML is a standard language for developing, documenting, identifying, and visualizing a software system by specifying the processed information in the processes and the system. In short, it is a language that represents the software system. UML diagrams include the Activity diagram, the class diagram, the collaborative diagram, the component diagram, the deployment diagram, the object diagram, the sequence diagram, the statechart diagram, and the use case diagram (Malmqvist, 2010b), Class diagrams will be illustrated and used in Chapters 5 and 7.

Chapter 4

Product Information in 2D Drawings

In this chapter, product information that exists or should exist on 2D drawings will be declared. The information was collected from literature studies, a number of 2D drawings, drawing note templates, and interviews. The chapter is arranged as follows: literature studies, product information existing on 2D drawings at Autoliv, and product information owners and users at Autoliv.

4.1 Literature studies

The data generated by upstream must be able to share to downstream effectively (Isaksson et al., 2000). Design engineers act like ‘the hub of the wheel’ since a designer is a center of all the roles and tasks for driving the efforts to reach final product design that could fulfill all of its stated requirements (Lowe, MacMahon and Culley, 2004). Kuffner and Ullman (1991) performed a study on information engineers are interested in, which is classified into four groups, according to ‘Nature’ of information. They include: Construction - information related to a geometrical structure of an object, Location - information associated with reference location of an object in space, Operation - information referring to an operation of assembled mechanism, and Purpose - information involved to a function of an object. Lowe, MacMahon and Culley (2004) also mentioned that product information exchange between engineers and other parties consists of: **G**eometry such as drawing and CAD models, **N**umbers including calculation, raw performance data, etc., **W**ords for instances, technical specifications, and **D**iagrams such as conceptual design schemes. In the same way, Isaksson et al. (2000) specify that various kinds of product information are contained in a product model which could include Analysis information, Geometry representations, Manufacturing information, Product configurations, Product features, and Product structures. To provide some idea of practical product information, some examples of product information on 2D drawing (according to British Standard) (Roymech, 2010) are provided as follows. They include Surface texture, Tolerance and limit, Component Dimension, Material, Technical specification (stress, stain, etc.), Production Note, Machined components, and Fasteners.

4.2 Product information existing in 2D drawings at Autoliv

Product information was gathered from company standard documents – AS 109 (Autoliv Standard) CAD Drawing and Model Standard (Waltzer and Dahlén, 2010), drawing note templates, and several drawings originated from various parts such as Seatbelt, Airbag, and Textile. Then, collected product information on the drawings was classified and grouped which was verified by interviewing some people from different departments to get some feedback from their experiences. Finally, the final version of the Generic Grouping was verified by reviewing from experienced users, tested by some sample drawings to verify its completeness, and standardized by STEP (Standard for the Exchange of Product Model data)

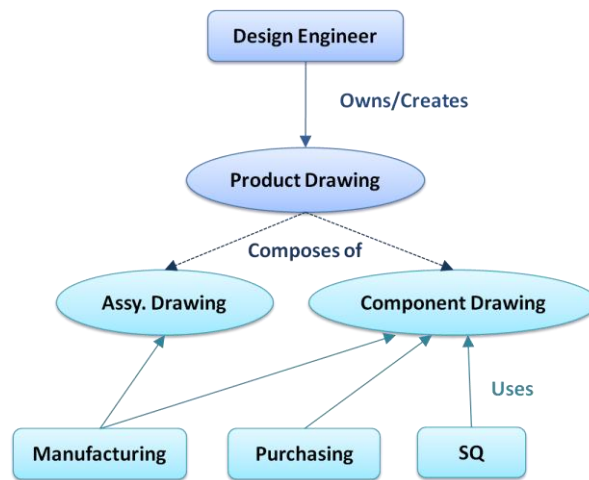

Figure 9: The relationship between product information owners and users and different types of drawings

standard AP 214 (Application Protocol), and Core data for automotive mechanical design processes (Mohrmann, 2000) for a final refinement.

4.2.1 Product drawings at Autoliv

There are a several kinds of drawings used in Autoliv. In this thesis, only the product drawing will be considered. Below are the terminologies defined according to their definitions in Autoliv’s PLM system. The diagram of the relationship between product information owners and users and different type drawings are defined in Figure 9.

- **A product drawing:** It is the drawing that contains the product information/requirements of a part or product, which consists of component and assembly drawings.
- **A component drawing:** It is a “part drawing,” a drawing of a component at the lowest level of a Bill of Material (BoM) or a so-called “drawing without any children drawing” (which is defined by Autoliv engineers).
- **An assembly drawing:** It is any drawing at a non-lowest level of BoM whether it is the final product drawing used by Autoliv in the assembly process or the sub-assembly drawing used by suppliers to assemble semi-finished components.

4.2.2 Product information classification

The collected product information regarding Autoliv’s product drawings is classified into several groups of information by using the KJ-Shiba method. The classification criteria are based on product information characteristic similarities and users’ functions of product information. The reason for classifying is that a great deal of product information exists in the drawings. Not all product information will be collected. These classification works are inputs to formulate a generic group of product information at Autoliv, which will be discussed later in the next section. The product information classification table is provided in Appendix B.2 at the end of the chapter.

4.2.3 Generic grouping of product information

The generic groups are taken from the groups stated in the classification table in Appendix B.2 and representatives of all product information which should cover all product information

in any Autoliv's product drawings. This section will provide the description of each representative group and sub-group which is the final version of the generic groups.

There are three main groups of information: Engineering specification/information, Manufacturing information/technique, and Verification requirements. The information is classified into three main cascade levels (x., x.x, and x.x.x). a), b), and c) are the 4th level of classification only for some complex elements including General pictorial and orthographic description, Other pictorial and orthographic description, Part/product definition, and Marking and printing. Below are the classification groups:

1. Engineering specification/information:

1.1 Pictorial and orthographic description

1.1.1 General pictorial and orthographic description: It is a general graphical representation that is found in 2D drawings which includes:

- a) Multiple view and projection on a drawing
- b) Cross-sectional view
- c) Exploded view: The view to illustrate about the assembly of part orderly
- d) Reference view

1.1.2 Other pictorial and orthographic description: It is a graphical illustration with textual description and indication on a part for purposes of describing and clarifying some specific part/view rather than merely presenting the view. This could include:

- a) Part or sub-part orientations (Only for assembly drawings)
- b) Text labeling on a part such as text embossing
- c) Feature illustration: Such as where to trim the edge and position of the hole

1.2 Dimension and Tolerances

1.2.1 Dimension philosophy: All dimension-related information

1.2.2 Geometrical tolerance: Profile tolerance, flatness, circular, etc.

1.2.3 Tolerance stack: Tolerance table and Dimensioning tolerance, such as worst case / statistical tolerance (such as $aa \pm bb$)

1.3 Part/Product requirements: Information covers all information and requirements of a part or product that defines that specific part or product.

1.3.1 Part/Product definition: It includes form, fit, function and utility of a part or product.

- a) Form and feature: The information that describes form, shape, and so on.
- b) Part/Product type: Anything related to part/product type
- c) Material: This includes a material related content, material summary, material used, material property, etc.
- d) Surface and texture: It includes colour, gross of the surface, surface texture/pattern/structure and so on of a part/ product

- e) Quality requirement: This information is related to the quality of the part produced that the fulfillment may or may not affect the final product function including a textual description about the quality, free of imperfection, free from cracking, no burr, etc.
 - f) Variants: The different number of options of a part/sub-part.
 - g) BOM: Bill of Material or Part list.
 - h) Traceability level according to AS 4, Product Traceability.
- 1.3.2 Technical information: It is technical information of a part or a product resulting from defining Part/Product definition since this information will be evaluated after defining shape, form and other definitions above. The information generally has a specific value, such as weight, stress, strain, torque, any technical limitation and so on.
- 1.3.3 Standard part/product: It is based on international, national, or industrial standards such as type of screw, thread, and so on.
- 1.3.4 Product certification/approval: Such as DOT and BAM
- 1.3.5 External requirement fulfillment: It is the external requirements that the part and/or product must meet. It may be according to customer requirements, legal requirements, and/or technical regulation.
- 1.3.6 Marking and printing: Indication of marking and printing on a part, such as marking and printing without any description (manufacturing indication, split-line, barcode, for example).
- a) Marking and printing for S (supplier): Marking and printing for component production purposes
 - b) Marking and printing for M (manufacturing): Marking and printing for assembly purposes
 - c) Marking and printing for C (customer): : Marking and printing according to customer requirements
2. Manufacturing information/technique: Information directly related to manufacturing such as manufacturing technique, how to position the tools, where to take the tool out and so on
- 2.1 Production process requirements: The process technology and information required to produce a part.
- 2.1.1 Production technology: The process technology or technique that is used to produce parts to meet product performance, such as casting, stamping, surface coating, etc.
 - 2.1.2 Production information: The information required along with the process technology to produce a part completely.
 - 2.1.3 Verification after production: A verification or check point that need to be fulfilled after producing a part/component.
- 2.2 Assembly process requirements: It is the assembly process or information required to fit parts together.

- 2.2.1 Assembly technology/technique: It is the process technology or technique used to assemble parts. Also, the activities needed to be done during the assembly.
 - 2.2.2 Assembly information: It is the information that needs to be aware of and the technical limitation of components during the assembly process such as tightening torque and so on.
 - 2.2.3 Verification after assembly: It is about the information regarding what to check and how to check that will be done by the manufacturing quality department at Autoliv. The verification scope here is basically to check almost everything stated in the drawing, including form, appearance, and fitting, excluding the note related to a function check of the part/product. This information could concern things like weight, strength, surface, gross, colour, check in fixture, and part fitting. This kind of requirement is often found on both component and assembly drawings depending on a characteristic of a note.
 - 2.2.4 Logistics information: It is information regarding how to treat the finished goods for instance, how to handle the goods. This kind of requirement is often found in the assembly drawing of finished goods.
- 2.3 Controlled manufacturing induced effects: Effects from a manufacturing process that is not desired but it cannot be avoided after the manufacturing process. It is things that need to be controlled during the process and also tool location which includes specific location for tool induced/ tool handling /tool separation location.
3. Verification requirements: It is about a function verification or quality check of a finished product which will be done either by suppliers or the quality department after assembly at Autoliv. This involves the need to ensure the completeness of the product after assembling such as check of presence, check of plausibility, etc. This kind of requirement is often found in an assembly drawing.

Some notes are related to reference documents (either internal or external) that are unorganized. The classification and descriptions of the documents, found in Appendix B.1, are categorized according to the type of a reference document.

4.3 Product information owners and users at Autoliv

4.3.1 Information owners

All information is created and owned by a design engineer. Design engineers include the department of Airbag, Seatbelt, and Inflator. The relationship of information owner and user related to drawing is shown in Figure 9.

4.3.2 Information users

- **Manufacturing**
 - Process: Use almost all of the product information depending on what kind of problem they are facing. They look at most of the information used in the assembly process in both component and assembly drawings that are included in

the group of 1. Engineering Specification, except 1.3.2 Technical Information and the group of 2.2 Assembly Process Requirements from the generic group.

- **MQ (Material Quality):** This department has the most experience and knowledge about notes on drawings since they see almost every drawing in Autoliv and use almost all information there. The information they use most is the dimensions on the drawing (to measure it) and also product information regarding the technical information form, fit, feature, and appearance of the part and product (to check it). They have never used the information regarding the function verifications of the product that are required to be checked after the assembly since that is another function responsibility.
- **Supplied Quality (SQ):** Use all product information from a drawing of a part or product that has been produced or assembled by suppliers except Pictorial and Orthographic description classification group.
- **Purchasing or a Project buyer:** Use all the product information of the drawing to make a decision on Material selection and Supplier selection.

Chapter 5

System Capabilities

This chapter will present the current CAD and PLM system capabilities at Autoliv separately and also provide some analysis of those capabilities that fail to fulfill the basic needs of a 3D master concept.

5.1 CAD-PLM system capability studies

5.1.1 Current e-part in the PLM system

The e-part or engineering part is the object most often used by designed engineers to design a part and manage the engineering of Autoliv's products. The e-part page is the main focus for PLM capabilities since the product information that will be moved from 2D drawing to PLM will be relocated under this object. The screenshot of the page is illustrated in Figure 10. Below are descriptions of items in the current PLM system. The information of this section comes from the second interview stated in Chapter 3.

- **Properties:** It displays technical information of a part from Engineer Data Record (EDR). EDR is a template that an engineer has to fill in before any new part is created. Different product types will have different templates.
- **Approval:** It indicates phase, task, assignee and so on related to approval process and tell where exactly the part is in the process flow.
- **History:** It shows the history of actions and descriptions of a part related to creates, changes, modifies, connects and disconnects.
- **CAD 3D:** It is a stored 3D CAD model that links to a part.
- **EBOM:** It is Engineering Bill of Material, which describes the composition of a part, including the material used in each sub-part.
- **ECOs:** It links to engineering change order documents related to a part.
- **ECRs:** It links to engineering change request documents related to a part.
- **Manufacturing Parts:** It is Manufacturing Bill of Material (MBOM).
- **Material Summary:** It summarizes all material used in a part onto one page and also provides links to get further information and related documents to each sub-part.
- **Principal Documents:** Mostly, it is a link to get to two things, 2D drawings of a part and Tool Requirement Documents of a part. However, sometimes it could be something else such as the composition of a Gas filled in Airbag.
- **Reference Documents:** Any additional document with the name format as E xxxxxx, which is related to a part, not a standard document, and may or may not be stated on the drawing of the part, will be stored here in a form of PDF or Excel. There is no precise description of what type of document could be kept here.

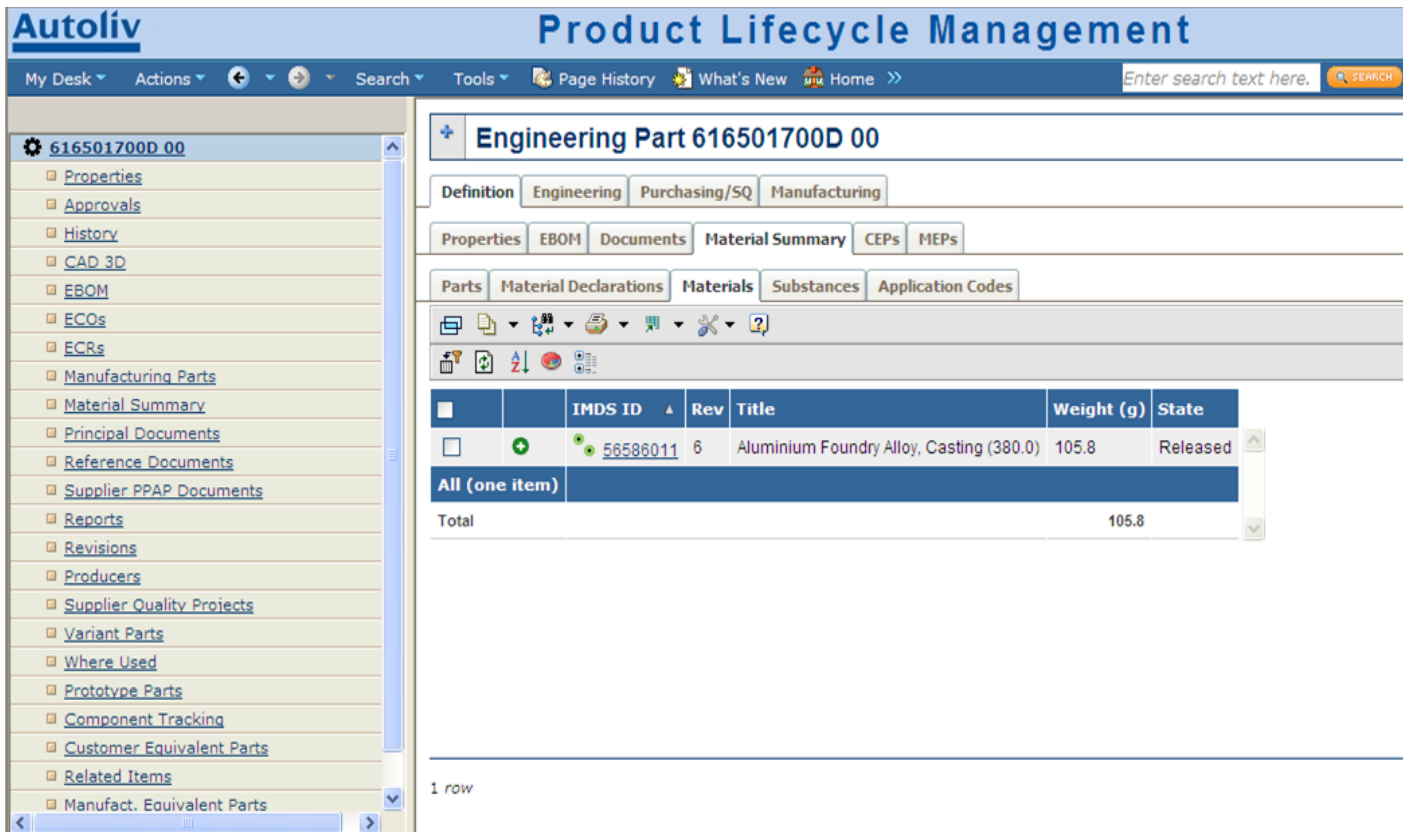

Figure 10: The current e-part page of the PLM system

- **Reports:** This attribute contains several links to create different kinds of reports depending on different usage purposes. There is no actual report stored here, but a requested report will be generated (upon a user's request) by using the information from the PLM database, which is done by add-on feature from the Technia-TVC report generator.
- **Supplier PPAP documents:** It is a link to Production Part Approval Process (PPAP) documents of all suppliers who are related to a part production.
- **Revisions:** It redirects you to links to all revisions of a part.
- **Producers:** It states the list of part producers, which are classified into two main group, Manufacturing groups and Suppliers. They are Autoliv's internal manufacturing companies and external manufacturing companies, respectively.
- **Supplier Quality Projects (SQP):** It stores a large pile of documents from the Supplier Quality Process. This document relates to approval, control, and agreements with suppliers who produce a part.
- **Variant parts:** It provides links to variants of a part. There are two types of variant parts, colour variants and symmetric variants such as side airbags that need to have left and right side-airbag.
- **Where used:** This is opposite to EBOM, since it details what product will use the part.
- **Prototype part:** This attribute provides links to every revision and version of drawings for prototypes of a part. It will be removed soon.
- **Component Tracking:** It is a table with data and used by purchasing department to track each component according to factors such as customer demands.

- **Customer equivalent parts:** This contains customers' part numbers for a part since customers do not know the part name of Autoliv and they have their own part number system.
- **Related Items:** There could be some different part sharing with common things such as platforms and modules, and this sharing part might have nothing to do with the project of a part. The link to sharing part can be found here.
- **Manufacturing Equivalent Parts:** It gives all manufacturing companies that can produce the same identical part for Autoliv as options for Autoliv and reductions of risks.
- **Assets:** It identifies a tool or machine that is related to a part and owned either by Autoliv or the customers but is located on the supplier site.

Note that the side and top navigations are similar. However, only the side navigations existed originally. The top navigations have just been introduced as they are more user-friendly due to new function oriented navigations. The overview information model of the e-part page is presented in Figure 11 which is divided into four separate pieces from the left to the right of Figure 11 for clear illustration, as seen in Appendix C.

5.1.2 Capabilities of existing licenses of CATIA V5

CATIA V5 R18, one of the Dassault systems' main products, is the existing CATIA version at Autoliv. The highest possible CATIA license at Autoliv with a possibility for a PLM connection is MD2_CT5. CATIA is used to create two main types of files that will be used throughout the product lifecycle – a 3D model and a 2D drawing. Most product information is located in both types of file with some overlapping. However, a 3D model is a master source for referencing if there is any information mismatch between a 3D model and a 2D drawing.

Furthermore, with this current license, it is possible to activate some other added-on applications and modules in CATIA purchased by Autoliv. Almost added-on applications are now used in production; however, only FTA was purchased only for testing. It has never been introduced to the users due to reasons such as training required. The existing extra modules in the current CATIA V5 license at Autoliv are:

- DMN – CATIA –DMU Navigator 2 Product
- FSS – CATIA – Freestyle Shaper 2 Product
- FTA – CATIA – 3D Functional Tolerancing & Annotation 2 Product
- GAS – CATIA – Generative Assembly Structural Analysis 2 Product
- GPS – CATIA - Generative Part Structural Analysis 2 Product
- GSD – CATIA - Generative Shape Design 2 Product
- KIN –DMU - Kinematics Simulator 2 Product
- KT1- CATIA – Knowledge Advisor 2 Product
- PHS – Photo Studio 2 Product
- SMD – CATIA - Sheetmetal Design 2 Product
- SPA - DMU Space Analysis 2 Product

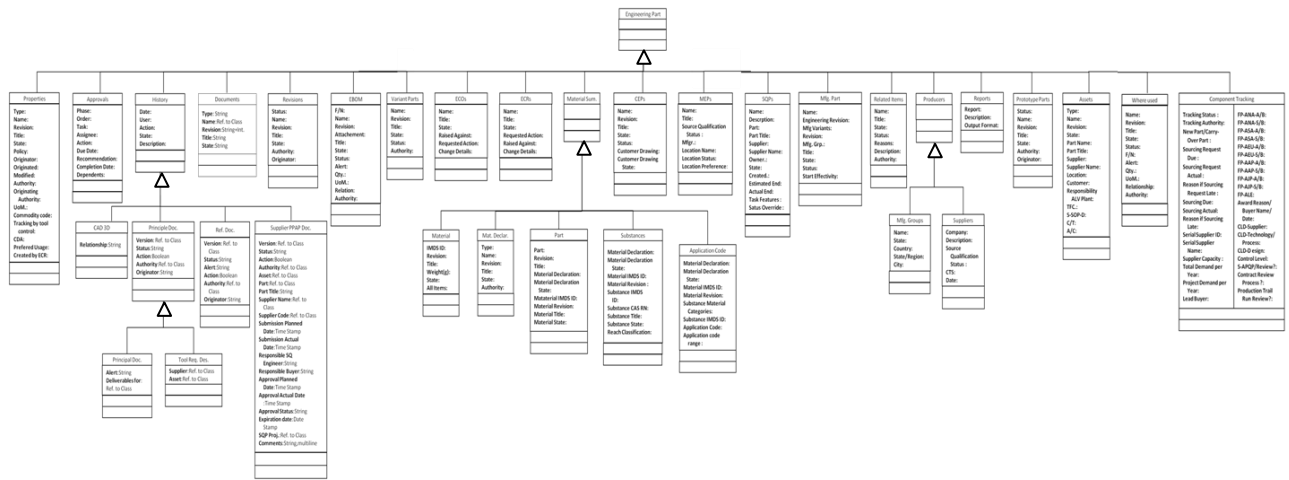

Figure 11: Information model of the current e-part page

- ST1- CATIA – Step Core Interface 1 Product
- STL – CATIA – STL Rapid Prototyping 2 Product

5.1.3 The integration within the CAD-PLM system

Figure 12 shows the existing CAX-PLM environment with users' role descriptions at Autoliv. One characteristic of the CAD-PLM environment at Autoliv is multi-CAD systems with a single PLM system as shown in Figure 12 with user's roles. There is an external separate viewing program outside the PLM system called Spinfire which can be used to view most kinds of CAD files. However, not all information can be presented here and it is complicated and inconvenient for the users to view the file outside the PLM system.

As mentioned before in Chapter 2, CATIA V5 and PLM Enovia MatrixOne are loosely integrated. They only exchange CAD templates, check-out CAD file from PLM to CAD, and to check-in finished CAD files from CAD to PLM. There is no actual connection to transfer product information among PLM, inside CATIA 2D files, and 3D files. This results in no exchange of product information among them. Hence, either PLM or CATIA files can store the same information without any inner linkages and transferring of information when either of them is changed or updated, resulting in redundancies and inconsistency of information.

5.1.4 Supplementary system

There is one supplementary system at Autoliv that supports the PLM system - Enovia MatrixOne. It is Technia Value Components by Technia, a supplier of PLM solutions for the creation and management of product information throughout the entire product lifecycle (Wikipedia, 2010b). This system currently is an added-on module that assists the PLM system, such as to generate the report upon the request, implementation of electronic BoM, etc. There are six value components from Technia that are currently executed at Autoliv's PLM system. They are the following:

User roles in existing CAX-PLM system

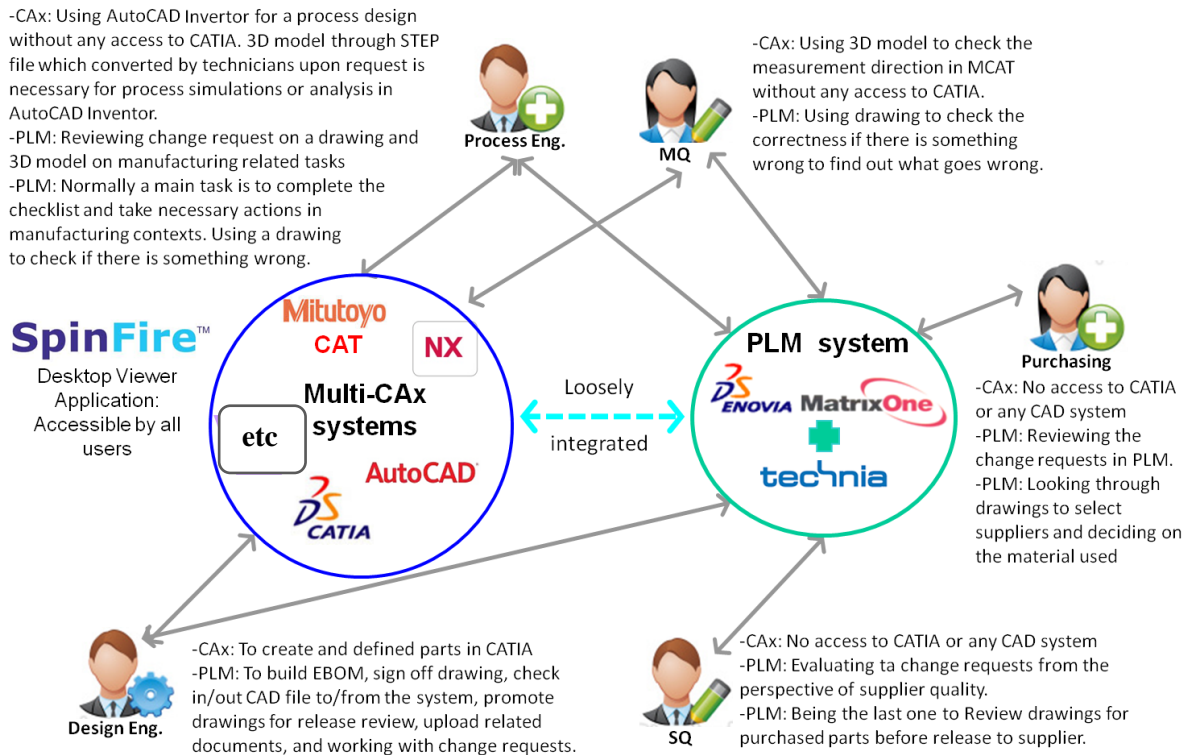

Figure 12: The existing CAX-PLM environment and user roles at Autoliv

- **Structure Browser:** It allows navigating, building and editing structures quickly and easily by providing a fully interactive visual representation of any structure, such as product and project.
- **Office Integration:** It simplifies document management functions by allowing Microsoft Office documents to be edited within Matrix PLM user interface. This results in a reduction of the steps in the check-in and check-out process since this process will be handled by the Office Integration Component.
- **Report Generator:** This component assists the PLM system to generate requested report from metadata in database. The output formats are PDF, HTML, XML, Excel, and Text with fixed width. Note that the metadata on documents in PLM is managed from direct database content (Oracle). (This function could be used.)
- **Grid Browser:** It provides columns and rows for different information object to support comparing and viewing different products, including the total feature content in the product portfolio, for example.
- **MCAD Optimizer:** It enhances the usability of MCAD integration based on ENOVIA Integration Exchange Framework by simplifying the Graphical User Interface and reducing the amount of dialog window and mouse-clicks.
- **XBOM Manager:** It is used to create baselines of business object structures from PLM databases and the management of multiple structures from Structure Browser. The XBOM Manager also contains structure comparisons and baseline management functions.

5.2 System analysis

This section aims to provide “existing pieces” and “missing pieces” analysis of current CAD-PLM system capabilities. The missing pieces are identified by comparing them to basic needs of a 3D master concept that are defined previously.

On the PLM e-part page, existing product information pieces that have been relocated in PLM before this thesis are Variant, EDR, and BoM. It is obviously that some information will be moved to the PLM e-part page. Hence, some modifications in the page are definitely required to support and suit the product information that will be located here.

In CATIA, almost all of the added-on modules and functions are currently used. However, only FTA has not been utilized in practice so far. It was purchased for particular reasons including testing and customer requirements. Some other purchased additional modules might be able to support the suggested system changes to create benefits and make use of existing investments.

In the CAD-PLM integration environment, it is obvious that any file viewing in a CAD system that is not a native CAD system of the file is always a problem. Although the users can use Spinfire to view most kinds of files that originate from different CAD systems and PDF reader to view 2D drawings in the form of plot file but the full product information from 3D models cannot be presented without the native CAD system of the source file. Also, most users complain that it is complicated to use external application, Spinfire to view. To conclude, there is no standardization of the created file format, and there is no central viewing tool or system for the users to view all information in one place. Even the interested CAD system in this thesis is CATIA V5. The CATIA V5 file should be able to share throughout the product lifecycle. There should be a system that is possible to view full information in one place during the whole product lifecycle. It could be an embedded system in PLM to provide a simple access for the entire product lifecycle users. Moreover, there are linkage issues between Autoliv’s CAD and PLM systems that do not allowed product information sharing, transferring, searching, and customizing among files or documents. These problems could be solved by enhancing CAD-PLM system integration and purposing that either a 3D model or the PLM system be a central access to obtain product information.

Finally, there are several useful Technia components that are implemented today. The report generator component is the function that was seen to be utilized for the future system. This is because it can be used to generate reports in PLM from the stored metadata, which is closely related to this analysis context.

Chapter 6

Requirement Definitions

This chapter will explain how to set up requirement definitions, some structured steps (including Business analysis and Business process design) and information analyzed from each step before formulating requirements, and present a requirement definition table at the end of the chapter. The requirement definitions are the requirements for the overall changes in a system.

6.1 Theory of requirement definition process

The requirements are the explanations of the services provided by the system and its operational constraints, which are based on the customers' needs and wishes (Sommerville, 2007). To define the requirements, there are three logical steps to follow (Malmqvist, 2010d). The steps follow below.

6.1.1 Business analysis

The first step is to provide input to formulate the requirements by assessing and analyzing the current situations and the problems of the business. This could be done by using informal and formal methods. Informal methods include interviews, workshop, benchmarking, and gap studies. Formal methods include SWOT (Strength-Weakness-Opportunity-Threat) analysis, CMM (Capability Maturity Model), and DSM (Design Structure Matrix) (Malmqvist, 2010d).

6.1.2 Business process re-design

This is a method for generating new process ideas. The methods that could be done individually are ones such as benchmarking, trade fair visits, trade literature studies, research publication studies, developing as-is and to-be models, and generating many scenarios and concepts (Malmqvist, 2010d).

6.1.3 Establish an initial requirement specification

The previous two steps have provided input for requirement formulation. This step is to cover needs and problems stated in the Business analysis and define the requirements to fit to the business process redesign. The software specification requirement document includes a description of the system vision, a list of potential improvements, and an initial version of the requirement specification, process model(s), an information model, and system architecture (Malmqvist, 2010d).

6.2 Implementation of requirement definition process

The theory of requirement definition process in the previous section is applicable for specifying requirements in diverse fields and industries. In this thesis, the requirements for the system changes are formulated. Hence, the theory will be adjusted to suit the thesis situation.

6.2.1 Business analysis

In this thesis, informal methods are used. CAD-PLM users' and the system's needs, problems, and constraints were defined by interviewing product information owners and users in Appendices A.1 and A.2 studying on system capabilities in Chapter 5, and analyzing company documents. The problems, needs, and constraints mentioned in the earlier chapters are concluded below.

1. Information redundancies: Information is located at least in a 2D drawing, a 3D model, and/or the PLM system. Not every piece of information is well-managed. There is no standard rule of putting "what" in "where" so information management is not possible. Hence, product information should be located in either the PLM system or a 3D model alone.
2. CATIA and PLM are not fully integrated: There is no product information exchange between these systems.
3. Information management and availability problems: Documents in PLM are not well-organized since not all important documents are stored there and there is no electronic link between some related documents. For example, some of the notes in most 2D drawings also refer to other documents which might or might not be accessible via PLM e-part.
4. CATIA accessibility and availability problems: Completed information on 3D models is not possible to access by everyone due to the license issue, multi-CAX system, and lack of computer resources in some places such as shop floor workers. However, the main purpose of the 3D model is to act as master information and for a supplier to make tool settings.
5. 3D CAD data exchange format: Due to the multi-CAX system environment, it is impossible to reuse 3D models in the system that is not a native system of the file. To be able to reuse in this case means enabling different CAX-users to use, change, analyze, measure, simulate and so on the file in other non-native CAX systems while still maintaining complete information in other non-native systems. Although there is a possibility to convert the file to some neutral file format, that format still cannot carry full product information. Besides, it is inconvenient for the users that need to ask and wait for technicians to convert the file upon a request.
6. External viewer application problem: It is complicated for the users to use Spinfire to view 3D models since it is not integrated to the PLM system and also not all information from 3D models can be seen by using the viewer.
7. There is no standard for notes on a 2D drawing: What the note looks like fully depends on each design engineer who creates the drawing. Some notes refer to the same thing, but probably use different words or phrases.
8. Autoliv's super 2D drawing: An Autoliv 2D drawing is a super drawing since all the product information that was used throughout the product lifecycle can be found here. A 2D drawing is one of the most important documents since it is not only a drawing, but also acts as a process document, a checklist, and a centre of communication throughout the whole product lifecycle. The drawing at Autoliv is more than a drawing, as it performs like a 'Super Drawing.'

According to the conclusions above, the solutions should have the potential to remove most of the above problems and fulfill some needs while still preserving all the information on the drawing in one place.

6.2.2 Business process design

In order to find the best new process, it is crucial to generate and evaluate multiple alternatives and not to quickly decide on one promising alternative. Generating many scenarios and concepts is seen as the most suitable method in this thesis since the main original task is to relocate product information into either the PLM system or a 3D model. Hence, it is crucial to provide the strategy for setting requirements.

6.2.2.1 Strategies for information relocation solutions

- *Strategy 1: Minimize contents in CAD approach:* According to the CAD-PLM environment at Autoliv (multi-CAX system with a single PLM), most information should be in PLM since it is accessible by everyone. However, some information not suitable to be located in PLM will be put into the 3D model. This information must be able to convert to a format that can be understood by the report generator tool in PLM.
- *Strategy 2: Maximize contents in CAD approach:* Locate the product information in the 3D model to make it carry as much information as possible in order to obtain the whole picture by using only the 3D model. But also provide the report generator function as a neutral file format for one that is not possible to use the 3D model.

6.2.2.2 Strategy selection: The strategy selection was done by using the Pugh matrix. The selection criteria are derived from the eight conclusions of problems, needs, and constraints from Section 6.2.1. That is because the strategy that has more potential to fulfill needs and constraints and eliminate the problems will be the winning strategy. The significance of the criteria is treated equally. Strategy 1 was compared to Strategy 2, which had been set as a datum. The analysis Pugh matrix table is depicted in Appendix E.1. It is obvious that Strategy 1 is better than Strategy 2. Minimizing contents in CAD allows managing product information through the PLM system, which is not possible in the 3D model. This will also solve the information unavailability and information redundancy problems. The integration between CATIA and PLM will be tighter because PLM will act as a center communication. Product information in both the PLM system and 3D CATIA CAD models will be available there. Minimizing the content in CAD will give a greater possibility of product information accessibility and availability, as everyone can access to PLM. For the other criteria, both strategies were seen to have equally capability to solve and fulfill. Hence, Strategy 1, Minimize contents in CAD approach, will be used as a strategy for the requirement specification and also the vision of system change.

6.2.2.3 Product information relocation: The generic groups of product information in Chapter 4 are representatives of the Autoliv product information. The lowest levels of the groups are re-categorized into a 'Higher Level of Grouping' to provide a clearer view to relocate them either to a 3D model or the PLM system. The higher level groups are divided into

five main clusters identified below according to the description characteristic of the product information. Each higher level group also tells where it should be located.

- A) **Textual description:** A long free-text description as a note on a drawing. This will be placed in the PLM for the possibility to search and manage. It consists of **1.3.1** Part/Product definition: e) Quality requirement, **1.3.5** External requirement fulfillment, **2.** Manufacturing information and Technique, and **3.** Verification requirements.
- B) **Feature illustration:** A graphical explanation without any texts. This will be put in the 3D model since it is 3D-related contents. It consists of **1.1.1** General pictorial and orthographic description, **1.1.2** Other pictorial and orthographic description, **1.2.1** Dimension philosophy, **1.2.2** Geometrical tolerance, **1.2.3** Tolerance stack, **1.3.1** part/product definition: a) Form and feature, and **1.3.6** Marking and printing.
- C) **Quantitative detail:** Information that can be seen or understood by only looking at its value. This will be relocated in the PLM in the EDR template since it contains only a value, a unit and some conditions, like MIN and MAX. Hence, it is suitable to put in the EDR template. It consists of **1.3.2** Technical information.
- D) **Property description:** A word or few words that can describe the part/product information. This will be relocated in the PLM in the existing EDR template since it is a short free-text description and value so it is suitable to put in an EDR template. It consists of **1.3.1** Part/product definition: b) Part/product type, **1.3.1** Part/product definition: d) Surface and texture, **1.3.1** Part/product definition: h) Traceability level according to AS 4, **1.3.3** Standard part/product, and **1.3.4** Product certification/approval.
- E) **Table / Hierarchy structure:** The piece of information describes a table or hierarchy structure. This kind has been solved by an existing solution in the PLM system. It consists of **1.3.1** Part/product definition: c) Material, **1.3.1** Part/product definition: f) Variants, and **1.3.1** Part/product definition: g) BoM: Bill of material/Part list.

6.2.3 Establish initial requirement specification

According to the theory part in Section 6.1.3, the software specification requirement document consists of six sub-documents. However, these requirements are the requirements for system changes. As such, the document will consist of five documents with some adjustments as follows. First, a description of the system vision is the implementation strategy in Section 6.2.2.2. Next, lists of potential improvements and the initial version of the requirement specification are provided later in this chapter. After that, the information model of the changes in the PLM system and ‘Holistic view of the suggested system with users’ roles’ depicted in Chapter 7, Figure 24 will be provided instead of a system architecture because the holistic view with users’ roles is sufficient and complete to describe information exchange among systems. The process model is not considered in this thesis since a process change is not in consideration in this thesis.

6.2.3.1 Lists of potential improvements

- Provides tighter integration between CAD and PLM systems.
- PLM functions as a central system for providing product information to the users regardless of different CAx systems (by single accessing).

- The users can dynamically view 3D models inside the PLM system.
- A possibility for product information customization according to a user's needs may exist
- Availability of potential data exchange format in the PLM system.

6.2.3.2 *Initial version of requirement specifications*: The requirement specification of the system changes are defined in Table 2. The requirements are divided into nine categories stated below. Each requirement contains a requirement description to clarify the requirement, a rationale to provide the reasons for the existence of the requirement, a demand/wish classification to emphasize the importance level of the requirement, a stakeholder to define people who will be affected by each requirement, a verification to provide a verification method for the requirement, and a fulfillment degree, which will be discussed later in Chapters 8 and 9. The following descriptions are the descriptions that need to be clarified.

- **Categories of requirements**: There are two major requirement categories, functional and non-functional. There are several types of requirements within those categories, but only the requirements mentioned in the requirement table will be described here (Sommerville, 2007).
 - Function requirements: The service of the system that states what the system should be able to do and how the system should respond to its input and situations.
 - Non-functional requirements include:
 - Usability requirements: It is a requirement associated to the usability of the system.
 - Reliability requirement: They are requirements associated to the reliability of the system, which can be measured in various ways, such as by failure rate of the system.
 - Organizational requirement: This requirement originates from the company policies, strategies, procedures, rules, and so on.
 - Implementation requirement: It states the method used, such as programming languages.
 - Interoperability requirement: This requirement tells how the system interacts with the system
 - Interface requirements: It specifies the interface between this system and other systems that it needs to work with.
 - Documentation requirement: It is a requirement of an official software requirement document that states the tasks to be implemented by the system developers
 - Delivery requirement: It is the requirement related to the time that the system will be delivered.
- **Demand and Wish**: Assigning Demand - a mandatory requirement that **MUST** be fulfilled - or Wish - a desired requirement that **SHOULD** be achieved - to a requirement is the way to prioritize the requirement (Almefelt, 2010).
- **Stakeholder**: Person or organization that may be positively or negatively affected by the execution of the system (Pinto, 2010).

- ‘Product information owners at Autoliv’ refers to Autoliv’s design engineers or any other roles that also create product information.
- ‘Product information users at Autoliv’ refers to the user of the product information that is created by a design engineer. These may include people from the Manufacturing, Manufacturing Quality, Supplied Quality, and Purchasing departments.
- ‘CAD-PLM System users at Autoliv’ refers to product information owners and users, both of whom are the CAD-PLM system users at Autoliv.
- ‘Customers’ refers to Autoliv’s customers.
- ‘Suppliers’ refers to Autoliv’s suppliers.
- ‘System developers’ refers to both internal and external software engineers, programmers and/or other roles who are involved in this new CAD-PLM system development for Autoliv.
- ‘Autoliv’ refers to Autoliv, Inc.
- **Fulfillment level:** As stated above, this will be discussed in Chapter 9. There are three levels of requirement fulfillment.
 - Completed: A requirement has been completely fulfilled by the suggested system
 - AD or Almost Done: A requirement is achieved to some extent by the suggested system. The undone tasks will be stated after the status.
 - VaI or Verified after Implementation: It is a requirement that can be verified after implementations of the suggested system.
 - Undone: It is a requirement that has not been fulfilled.

Table 2: The requirement specification table of the system changes

Requirement Definitions						
Category	Requirement	Rationale	Demand/ Wish	Stakeholder(s)	Verification method	Fulfillment Level
Function Requirements	- Dimension, geometrical, and dimensioning tolerance: Possible to put dimension and tolerances on 3D model	- Dimension and tolerance are suitable to place in a 3D model.	Demand	Product information owners at Autoliv	- Testing: Possible to put Dimension, geometrical, and dimensioning tolerance in the 3D model.	Completed
	- Note text: Some note texts according to the classification criteria must be able to be put in the PLM system and stored in the database.	- Some note texts are appropriate to store in the PLM database.	Demand	Product information owners at Autoliv	- Testing: Function to add note texts in the PLM system is available.	Completed
	- File viewer: All product information originated either from the existing 3D model or the PLM system can be seen inside the PLM system.	- To enable all users to view and use a 3D model without any CATIA license required.	Demand	Product information users at Autoliv	- Testing: Possible to view a file outside CATIA.	Completed
	- Searching function: Possible to search for information in the existing drawing by using the searching engine in the PLM	- Easy for the users to search and receive only their related product information.	Demand	CAD-PLM System users at Autoliv	- Testing: Possible to search for note texts in PLM.	AD - Browsing function is used instead.
	- Document generator: The system should be able to generate some kind of drawing replacement documents, such as customized drawings, that should be able to combine information from the 3D model and the PLM (input) together into one document package in the form of some neutral format document (output).	- This function mainly provides for information users, who cannot access to a computer, such as people on a shop-floor and for others to read the file by simply using the general neutral format reader (freeware).	Demand	Product information users at Autoliv, customers and suppliers	- Testing: Possible to generate document package from PLM.	Completed
	- Customized information: Possible to customize to only view suitable product information (as categorized in the classification table) for each user's function and role.	- To make possible for people to view only the information their related contents. Information filtering leads to convenient and easier to use and look for the desired information user oriented information).	Wish	Product information users at Autoliv, customers and suppliers	- Testing: Possible to customize product information to view in PLM	Completed
	- Customized view: Possible to select several desired views of the 3D model before printing.	- The purpose of this function is to allow people to choose any view that they are interested in to support their function and tasks (a user oriented view).	Demand	Product information users at Autoliv, customers and suppliers	- Testing: Possible to select views before generating documents.	Completed
	- Live drawing: Possible to rotate 360 degrees to see the whole picture of a part by using some neutral file format.	- To see the whole picture of a part for information accuracies and precision.	Wish	Product information users at Autoliv	- Testing: Possible to rotate the model outside CATIA.	Completed
- Change and update: Possible to update the information in the PLM and the 3D model.	- It must allow for and follow the change management process, and not all requirements are specified once the very first time.	Demand	Product information users at Autoliv, customers and suppliers	- Testing: Possible to change and update the information in PLM and the 3D model.	AD - product information is possible to change or edit, but it has not been controlled by the change management process.	
Usability Requirements	- Friendly user interface: Easy and convenient to create, use and look for the information Demanded in PLM	- New function should support all users' working routines and not make their tasks more complicated.	Demand	CAD-PLM system users at Autoliv	- Measuring: Training time and number of help frames.	VAI
	- Acceptable waiting time: waiting time for generating a document package should be reasonable.	- This new system should support the working routine to proceed faster and easier.	Demand	CAD-PLM system users at Autoliv	- Measuring: Processing time and response time.	VAI
	- PLM as a center: Desired product information is accessible via PLM.	- To support the users' working routines to receive required information by single accessing to the PLM system.	Demand	CAD-PLM system users at Autoliv	- Measuring: Rate of product information missing in PLM occurrence or rate of unavailability of product information in PLM.	VAI
	- Drawing replacement document requirements: it must at least preserve all the information in an existing drawing.	- The new drawing replacement document should contain all the information in the current drawing, to preserve the existing working routines as much as possible.	Demand	CAD-PLM system users at Autoliv, customers, and suppliers	- Document verification: Possible to present information from current drawing.	Completed
	- EDR (Engineering Data Records)			CAD-PLM	- Document verification:	VAI

	template requirements: An existing EDR template for each specific part must be extended and modified to support the change.	- To support the new changes since some notes from an existing drawing will be put in here and it will be the only source for storing this kind of note information.	Demand	system users at Autoliv	Verify new EDR template.	
Reliability Requirement	- Information accuracy: The system must store and preserve any input information at the right place. When it is required by a user, it must be available and able to present upon request without any error.	- Reliability, consistency and accuracy of information stored in the database.	Demand	CAD-PLM system users at Autoliv	- Measuring: Rate of failure occurrence and probability of unavailability.	VAI
Organizational Requirement	- Single source of product information: Product information is stored in only one single source, referred to as an information master source either in the PLM or a 3D model	- To reduce information redundancies, inconsistencies, and information island problems.	Demand	CAD-PLM system users at Autoliv	- Verification: Product information stored in only one place.	Completed
Implementation Requirements	- The modification must be based on Autoliv's current, customized ENOVIA MatrixOne PLM.	- ENOVIA MatrixOne is the current Autoliv PLM system.	Demand	System developers	- Verification: Modification base on the current PLM system.	Completed
	- Information model must be defined in the form of Unified Modeling Language (UML).	- UML is the language used by ENOVIA MatrixOne.	Demand	System developers	- Verification: Using UML information model.	Completed
	- For CATIA V5, Visual Basic script is preferred as a programming language since it is the language that CATIA V5 understands.	- It is the language that CATIA V5 understands.	Demand	System developers	- Verification: Using VB script.	VAI
Interoperability Requirement	- CAD-PLM integration: Tighter integration between the PLM and the CAD system.	- It is a consequence of the change to utilize the maximum potential and capabilities of the system.	Wish	CAD-PLM system users at Autoliv and system developers	- Testing: Information exchange is possible between a 3D model and PLM.	Completed
Interface Requirements	- Neutral output file format: Any output files must be in a form of potential neutral format, which can preserve all geometrical product information	- To make possible for both internal and external product information users to view the 3D model and its product information without any CATIA license required. For the internal user, the file can be viewed through the PLM system. For the external users, including customers and suppliers, they can use some kind of freeware viewer to view the file.	Demand	CAD-PLM system users at Autoliv, customers, and suppliers	- Testing: Using some kind of freeware to view an output file.	Completed
(exchange format with other system, not a user interface)	- (Future requirement) Neutral exchange file format: In addition, the neutral exchange format that can be used to share product information between upstream and downstream CAx system should be defined.	- To make possible for those internal users who demand it to correct, change, and analyze the part by using the same file throughout the product lifecycle.	Wish	CAD-PLM system users at Autoliv	- Testing: Trying to use the same file in a different CAD system.	AD - the format feasibility study for the overall CAx applications and testing is required.
Documentation requirement	- (Future requirement) The software requirement document which describes the system for the system's developer. It should be provided.	- To provide the scope of works and tasks that the system developers need to succeed the changes.	Demand	Autoliv and System developers	- Verification: The document available on Autoliv's wiki pages.	Undone
Delivery requirement	- The development time and the delivery date: They should be specified.	- Time required for development is an important factor to be considered in the system development.	Demand	CAD-PLM System users at Autoliv, System developers, Autoliv, Customers, and Suppliers	- Verification: The approximate time required and delivery date are defined.	Undone

Chapter 7

Future System Design and Implementation Plan

The main focus of this chapter is to provide descriptions of tentative solutions as a result of the requirement definitions formulated in the previous chapter. The content of this chapter includes purposed solutions and suggestions, gap analysis, and system evaluations.

7.1 Solution proposals

The suggested solutions are divided into two main categories. The first category is divided into three main topics: the solution of PLM, CAD, and the alternative solutions for a document generator. The second category is the suggested potential neutral 3D data exchange format within the multi-CAx system.

7.1.1 PLM

There are several changes in the PLM e-part page since it is the main page for design engineers to share the product information that has been created with users throughout the product lifecycle. However, this part will focus on the changes of the e-part page. Other changes will be specified later in this chapter.

7.1.1.1 Information model of note texts: According to the information model in Chapter 5 Section 5.1.1, there are changes that are marked in red in the first section of the information model since the information relocation is related to the Documents Class. The Product Information class will be added under the Documents class. The modified objects are shown in Figure 13. There are three main classes that are sub-classes of the product information class. Each class is derived from the information relocation group in PLM in Section 5.2. The object classification is based on the characteristics of each attribute and its value type. The first main class is the General Descriptions derived from the Texture description group. Most of the note texts that exist on the 2D drawings will be migrated here. The characteristics of a note in this group are free-text notes of one of two possible types: either general free-text notes or free-text notes with a reference document resulting in two type of attribute values - String with multi-line and Reference to other class. The second main class is common EDR obtained from Property descriptions which will be extended from the existing common attributes of EDR. This type of class contains only attributes that are shared among all parts and products. Their values are string as well, but not multi-line, since these attribute values will be just short text description. The last main class is Specific EDR, a part that contains a numerical value with its unit and conditions acquired from Quantitative detail group. Also, attributes of this class will be specific to a particular type of part and product.

For the most part, the attribute value will be either integer or float with short strings for its unit and condition. However, it can include short strings as well, which required further studies on specific attributes of each part. The attributes of each class are specified in Figure 13.

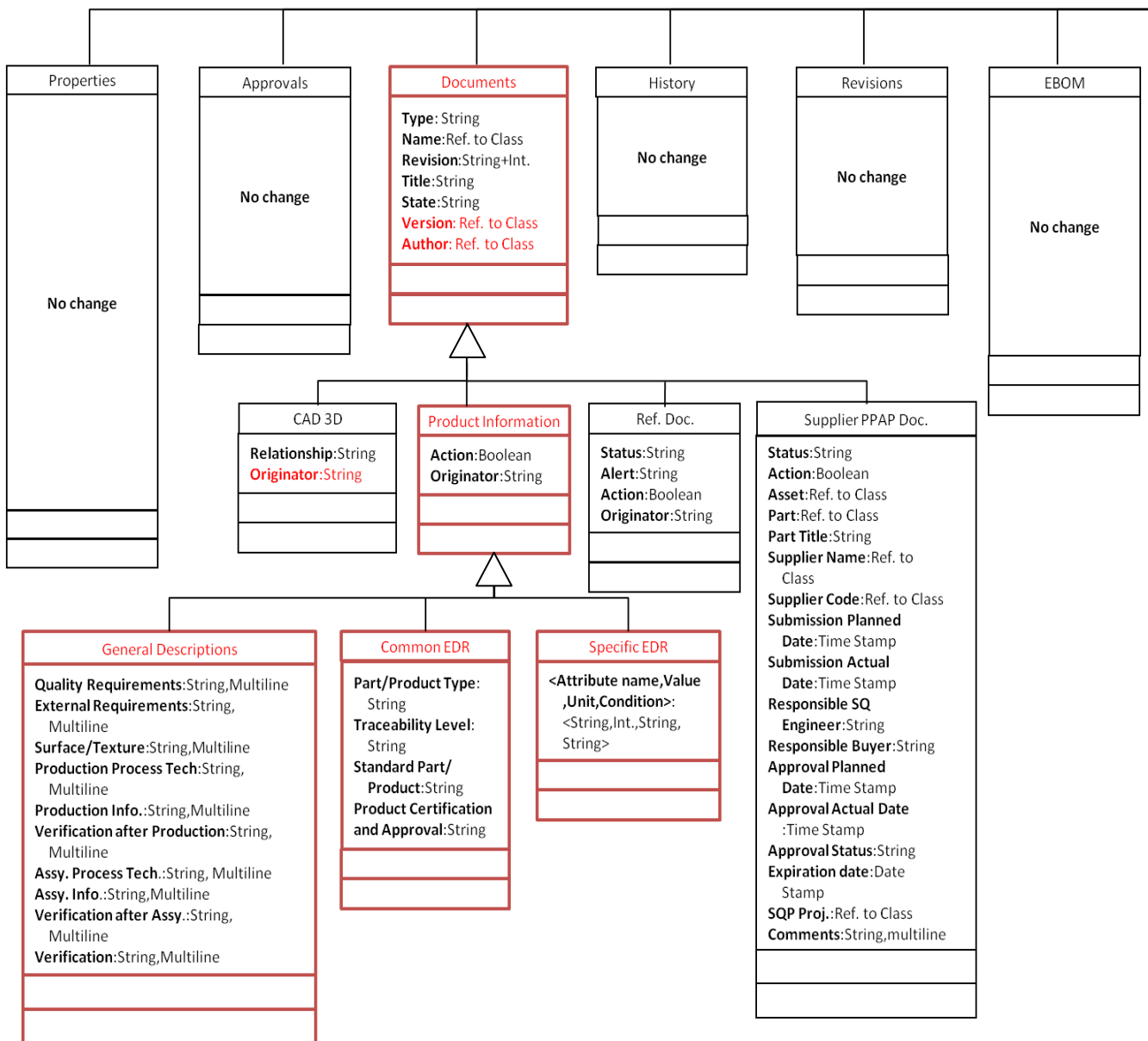

Figure 13: Modified information model

7.1.1.2 *User interface under in product information navigation:* The e-part page user interface must be modified to support changes. The product information navigation must be included in the page. General descriptions, Common EDR, and Specific EDR links to view the information should be provided under product information navigation with three other major functions - Create, Edit, and Report. Some example screenshots of the user interface-mentioned changes are demonstrated below. The illustrated appearance begins with the product information view of general description notes, is then followed by a product information view of Common EDR, and a product information view of Specific EDR in Figures 14, 15, and 16, respectively. Also, an example demonstration of the “Create” function process of the product information in Figure 17 will be shown.

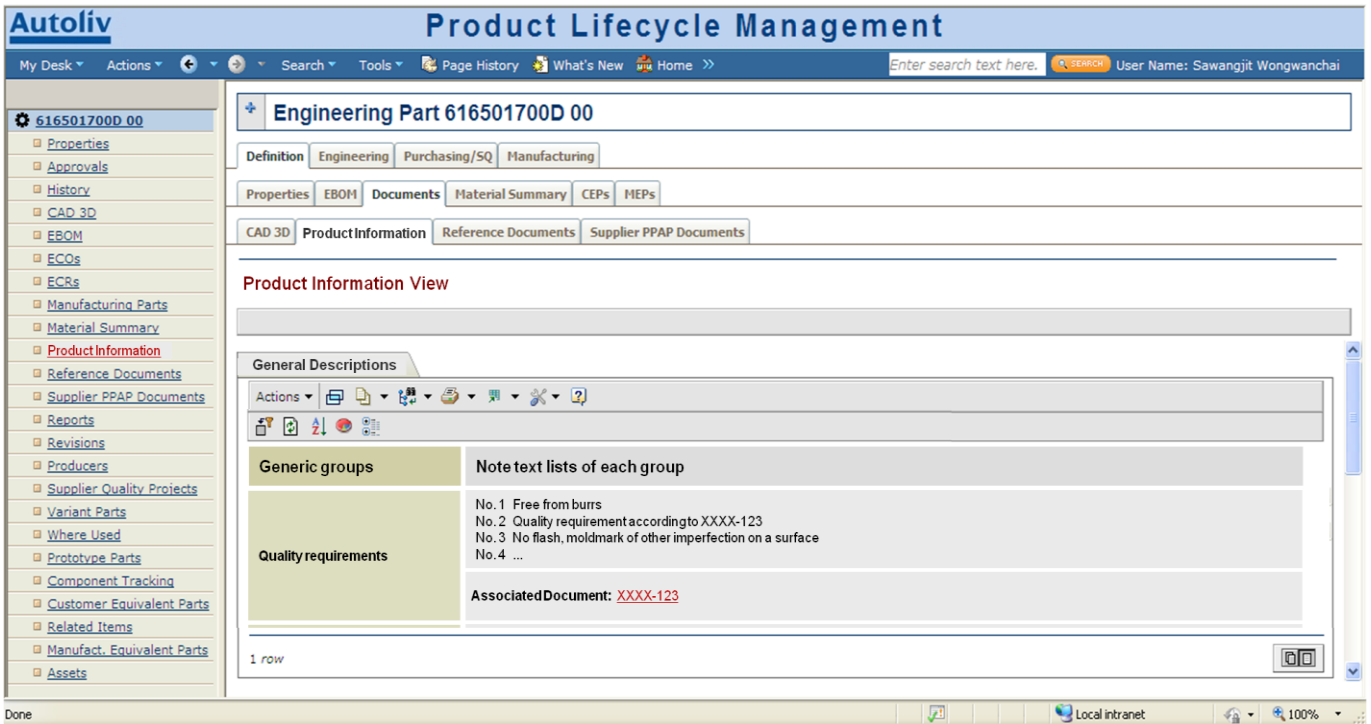

Figure 14: The product information view of General description notes

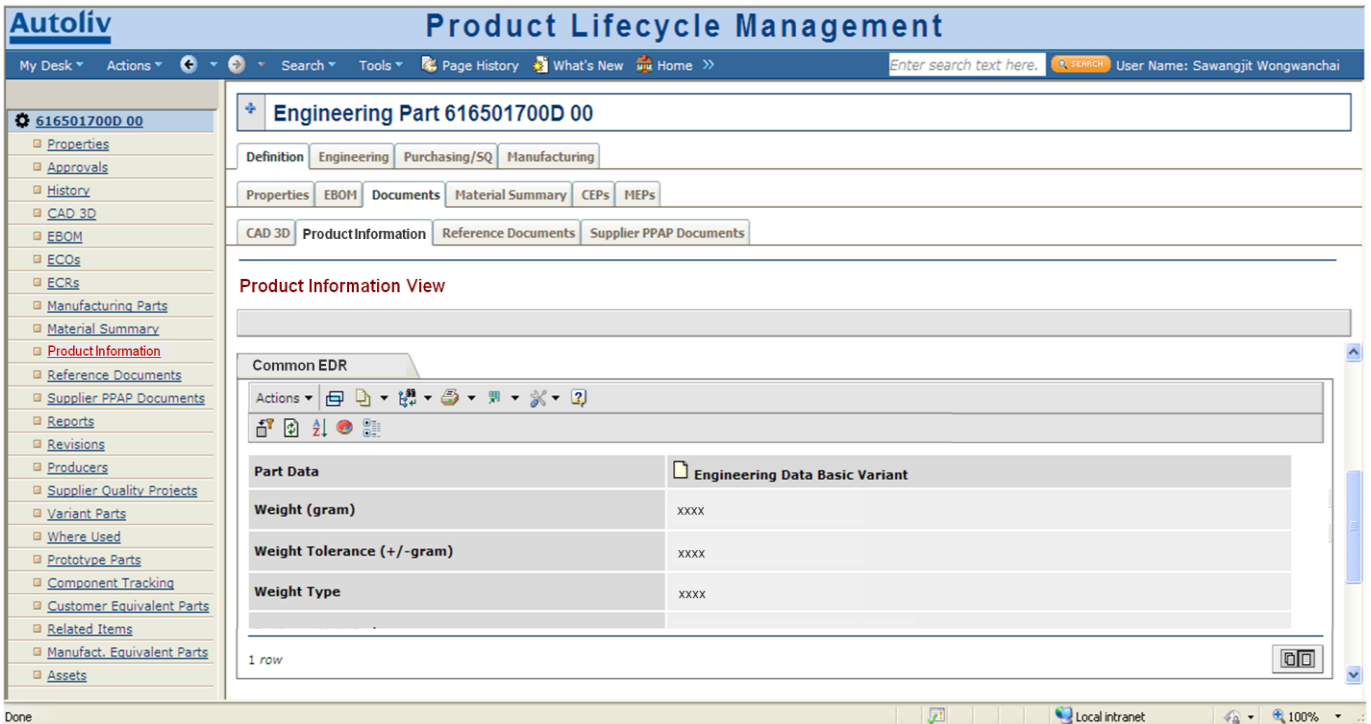

Figure 15: The product information view of Common EDR

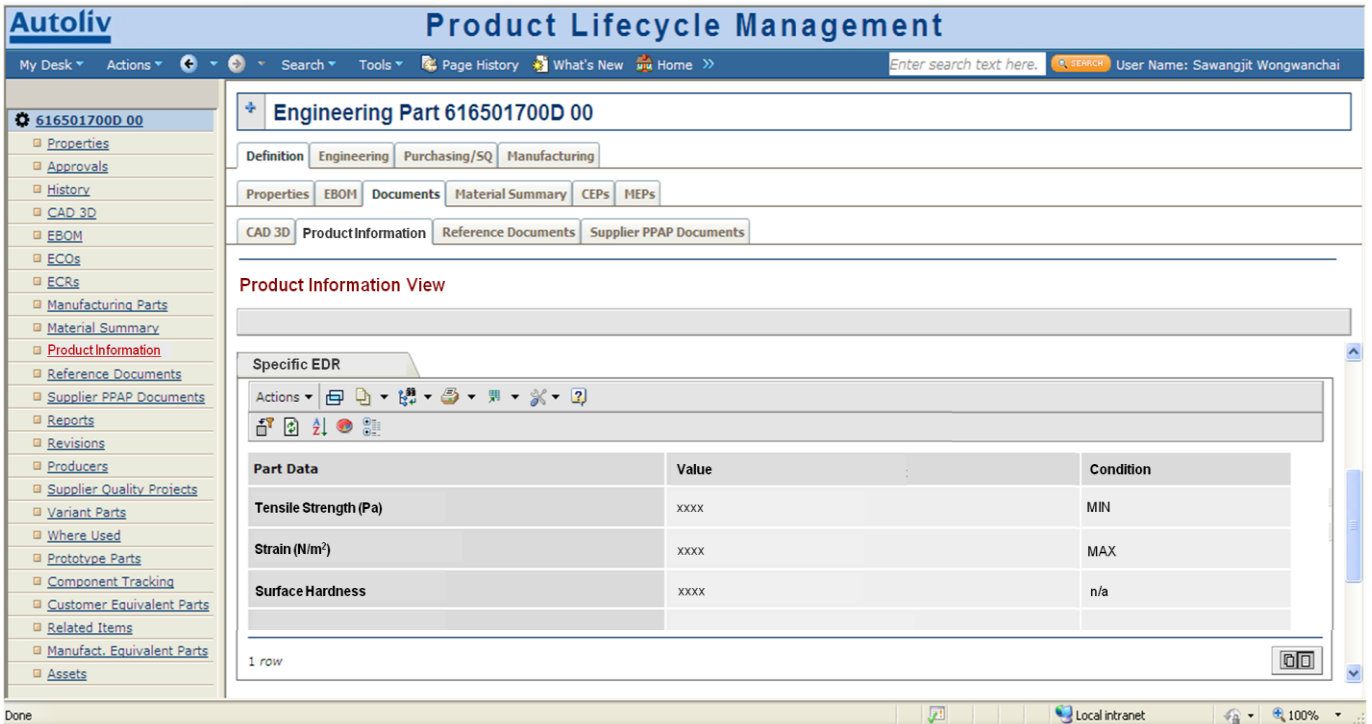
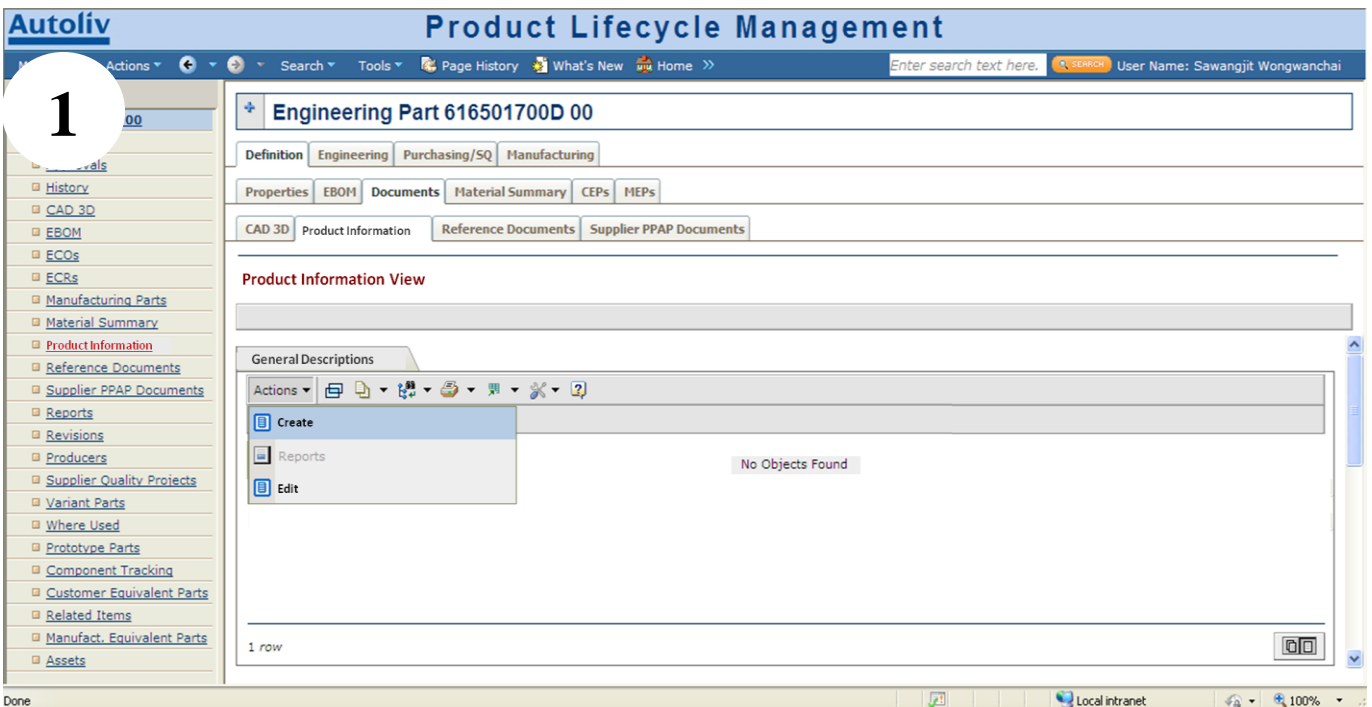
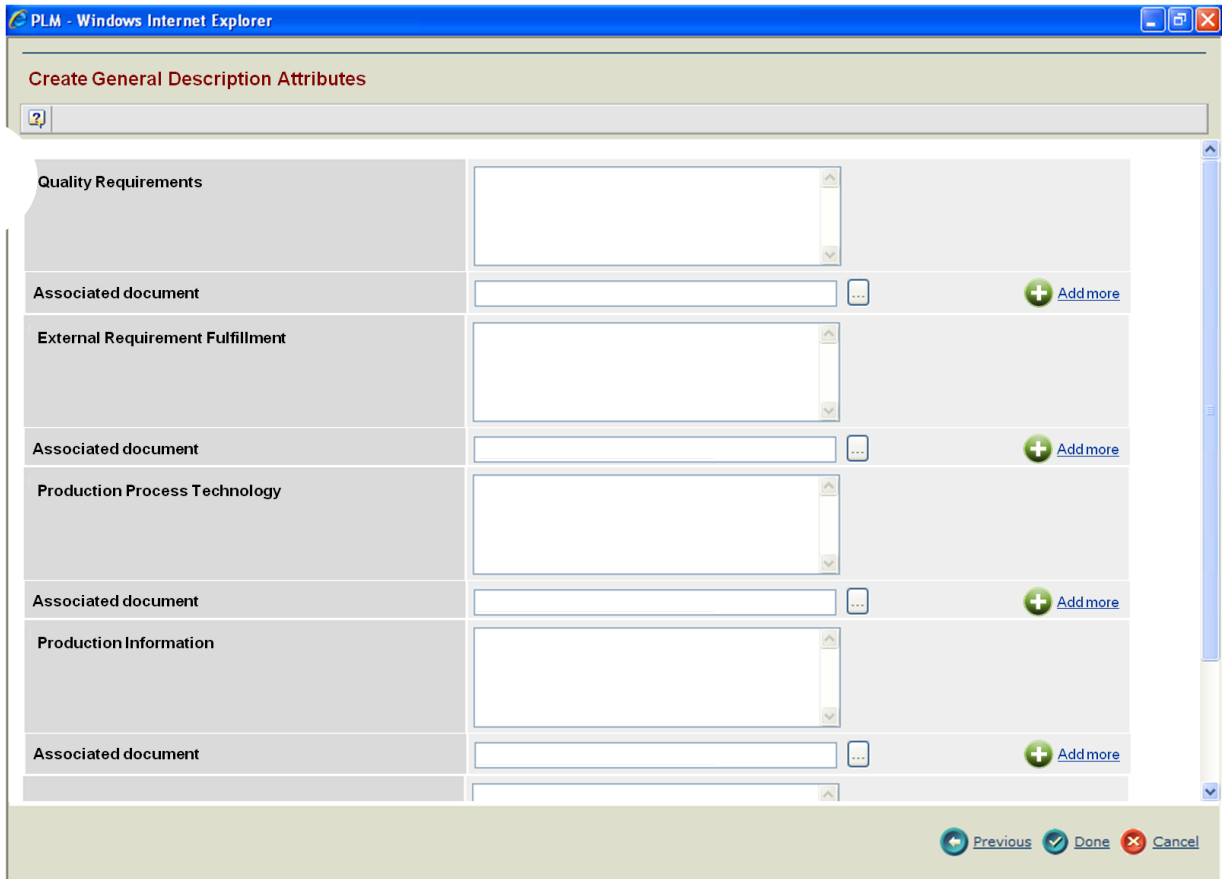

Figure 16: The product information view of Specific EDR

Figure 17: Three steps of note creation process



2



3

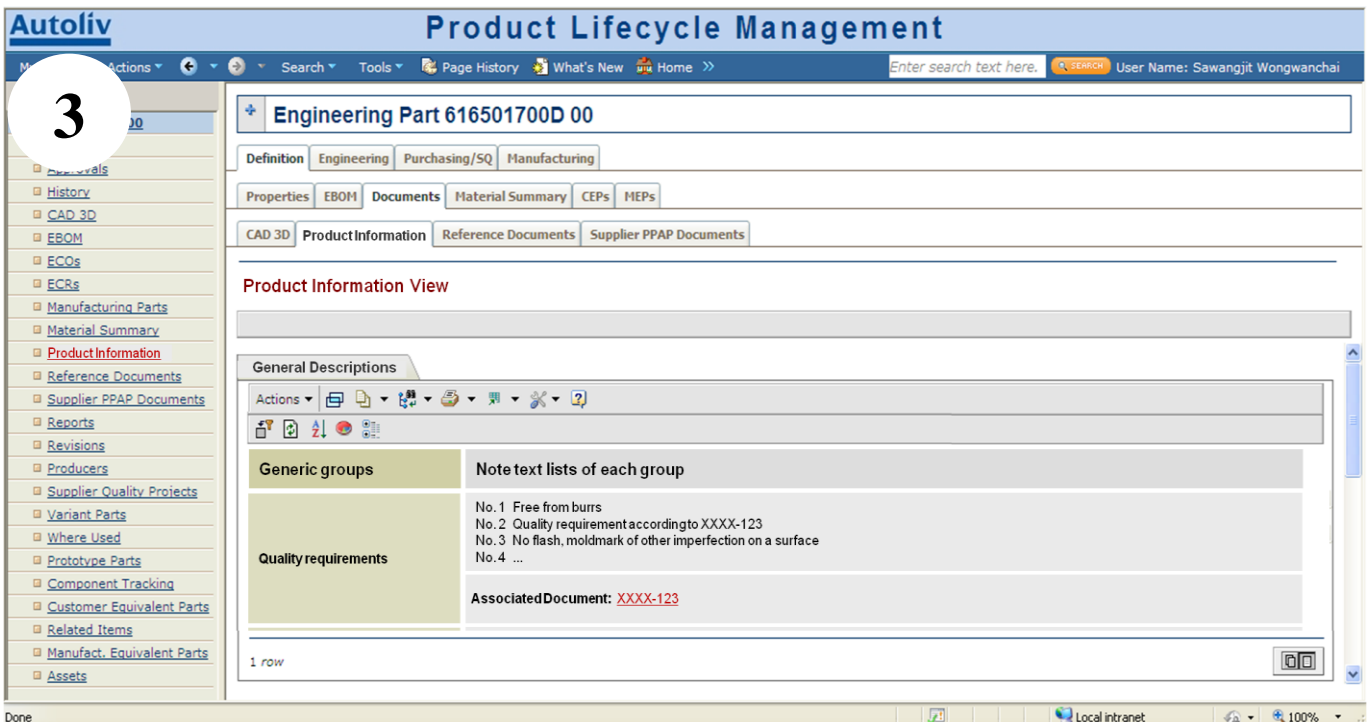

7.1.2 CAD

In this topic, a suggested solution that could fulfill requirements involving putting geometrical product information in the 3D model will be discovered here. Many options have been investigated during the study in order to achieve the requirements. These options

include FTA (Functional Tolerancing and Annotation), RD&T (Robust Design and Tolerance), and Visual basic scripts. However, it was found that the RD&T and the scripts did not have the competence to fulfill all the related requirements. RD&T is a more analysis-oriented program, while writing the scripts will take some time to develop and not all the needs can be completed. Hence, only the FTA module will be discussed further.

7.1.2.1 3D FTA Module: The FTA module stands for 3D Functional Tolerancing and Annotations. Its main function is to define and manage tolerance specification and annotations on 3D parts and products in order to reduce any 2D drawing dependency and master the geometry product information on 3D representation. An example of part with 3D representation is shown in Figure 18.

- **Main product key** (DassaultSystemes, 2008b)
 - Provides a comprehensive set of associative annotations, text, flag-notes, datum, datum targets, geometrical tolerances, and roughness dress-up features in 3D format.
 - 3D dimensioning and tolerancing in part, product and process documents.
 - Totally related to 3D part or product.
 - Multiple display and filtering options.
 - Functional tolerancing and annotation generative dimensions from CATIA-Part Design.
 - Full compliance with the latest revisions of major standards: ISO, ANSI, JIS supported/full NLS compliance and DBCS support.
 - Format model: 3D PMI or 3D Product Manufacturing Information: It is a 3D model with 3D geometry information, such as dimension, tolerances or surface accuracies.

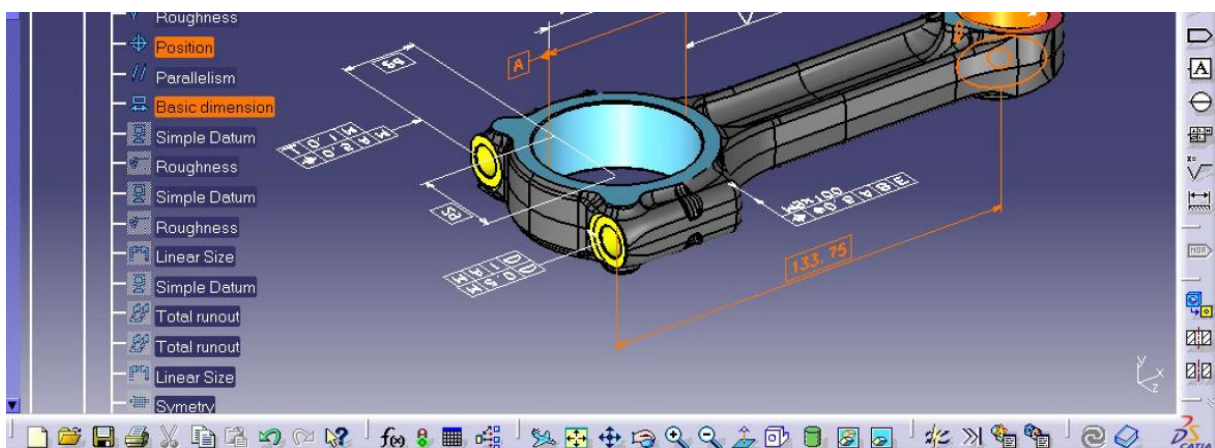

Figure 18: Example of a part created from FTA module (DassaultSystemes, 2008b)

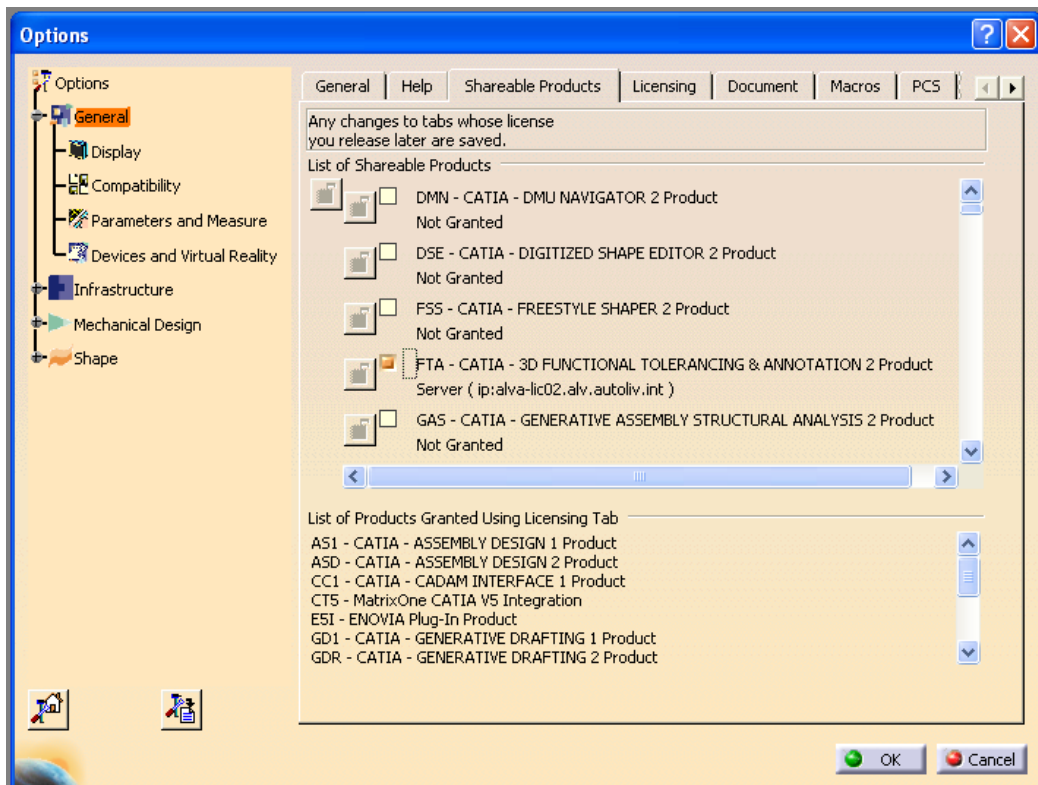

Figure 19: Activating FTA license in CATIA V5

- FTA License:** FTA is an additional module for CATIA from Dassault. There is only one kind of FTA license. Fortunately, FTA has been purchased by Autoliv EU for some time; they see the possibility to manage data in 3D models. The purpose of this purchase for now is for customers only for testing. However, it has not been utilized in practice since there has been no standard formulation concerning putting this information in a 3D model yet, Furthermore, training is definitely required to do so.

It is necessary for Autoliv users to have 5HTA CATIA license in order to use FTA. After the CATIA V5 work station is opened, the users can work on the FTA module by clicking on: Tool >> Option >> General >> Sharable Project tab. Activating the FTA module option is done under the Sharable Products tab, as shown in Figure 19.

7.1.3 A document generator system

Because product information will be relocated in two places, the PLM system and a 3D model as declared above, the document generator system is required to combine information from two places. It is also to provide an opportunity to include other relevant documents into the generated document. The author has been searching a great deal in the market to look for a system that could fulfill the requirements formulated above. There are two potential systems that might be able to fulfill the requirements, ProSTEP 3D Generator and 3dvia Composer. Their details are given in Appendix D.1.

Table 3: Document generator system comparison table

Criteria	ProSTEP	3dvia
Purpose of the system	ProSTEP can combine various kinds of information from different locations and formats that are utilized in PLM system into one single package in a 3D PDF format. Its purpose is to allow non-CAD consumers to use CAD files and other related documents without CAD license limitation.	3dvia is used to gather documents and files related to a manufacturing process from different locations and formats. The purpose is to enhance and support manufacturing process by using animation such as animation of how parts assembled for a product.
User friendly: Easy to use and access to reduce complications	It depends on individual system interface design.	Some training is required to use the system properly.
File format for viewing and interacting by using computer: Possible to use freeware to view	3D PDF	Internal lightweight file format
Printable format	PDF	Microsoft office form, PDF, and some other standard format
Capability to pack complete information into one single document	Yes, 3D PMI model and some other information from PLM.	Not quite, 3D model without 3D PMI information and some other documents
Customization ability	Yes	Yes
Possible to embed or integrate the generator and viewer into the PLM system for internal users' convenience to use	The generator is compatible with ENOVIA, and the viewer is Adobe Reader 9 (or later), which can be integrated to the PLM system.	Both generator or composer and viewer are the desktop application, none of which are possible to integrate into the PLM system.
File viewer	Adobe Reader 9	An interactive model can be viewed by using 3dvia Player freeware or 3dvia Player Pro. A generated document can be viewed according to the generated native file format, a standard PC application format.

7.1.3.1 System comparison: To conclude, both systems mentioned above have the potential to fulfill needs and requirements. However according to the comparison table in Table 3, ProSTEP matches up well with stated requirements and suits the scope of interests better than 3dvia. The overall perspective of ProSTEP is to gather several kinds of documents together in one document package. This includes the possibility to dynamically interact to 3D data in the package by using a basic PDF reader, a standard program on every PC. On the other hand, the main goal of 3dvia emphasizes more on animation to enhance the manufacturing context. The users need to use its special program to view interactively. Although it is freeware, it is an uncommon program and it cannot be integrated into a PLM system. Even though it is possible to generate a standard format of a document package from several different kinds, but it is impossible to interact to 3D data in this document package. Hence, ProSTEP is more compatible with being a document generator than the other and directly solves the underlined problems in the aspects of this thesis.

7.1.3.2 Document generator user interface in PLM system: In the previous part, the options of the new additional module that can combine all required documents into one package were discussed. In this section, the screenshot of the user interface in PLM in generating the document will be demonstrated. There are four main links added into the Select Report page. They consist of the following: a General Description Report, a Technical Description Report, an EDR Report, and a Customized Drawing. The first three report generating processes will be similar since they will be done by the Technia TVC Report Generator. The process of creating a general description report will be exemplified in Figure 20. On the other hand, Customized Drawing will be created through either of the system options discussed in Section 7.1.3.3, resulting in a slightly difference in the process. It will be exhibited in Figure 21.

Figure 20: Four steps of the process of creating a general description report.

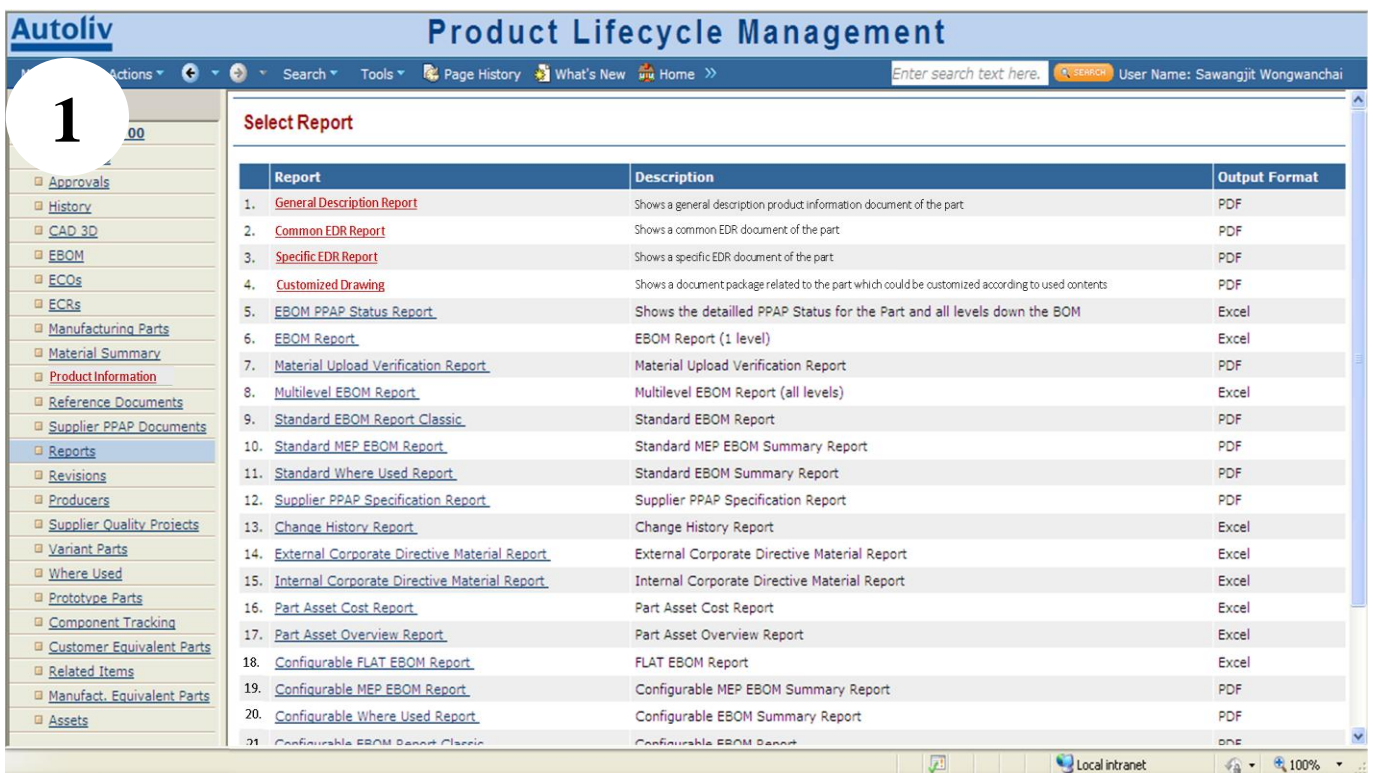

2

Autoliv Product Lifecycle Management

Search Tools Page History What's New Home Enter search text here SEARCH User Name: Sawangjit Wongwanchai

Select Report

Report	Output Format
1. General Description Report	PDF
2. Common EDR Report	PDF
3. Specific EDR Report	PDF
4. Customized Drawing	PDF
5. EBOM PPAP Status Report	PDF
6. EBOM Report	Excel
7. Material Upload Verification	PDF
8. Multilevel EBOM Report	Excel
9. Standard EBOM Report	PDF
10. Standard MEP EBOM Report	PDF
11. Standard Where Used Report	PDF
12. Supplier PPAP Specific Report	PDF
13. Change History Report	Excel
14. External Corporate Directory	Excel
15. Internal Corporate Directory	Excel
16. Part Asset Cost Report	Excel
17. Part Asset Overview Report	Excel
18. Configurable FLAT EBOM Report	Excel
19. Configurable MEP EBOM Report	PDF
20. Configurable Where Used Report	PDF
21. Configurable EBOM Report Classic	PDF

TVC Report Generator - Windows Internet Explorer

TVC Report Generator

Enter Values

Quality Requirements

External Requirement Fulfillment

Production Process Technology

Production Information

Verification after Production

Assemble Process Technology

Assemble Information

Verification after Assembly

Verifications

Continue Cancel

3

Autoliv Product Lifecycle Management

Search Tools Page History What's New Home Enter search text here SEARCH User Name: Sawangjit Wongwanchai

Select Report

Report	Output Format
1. General Description Report	PDF
2. Common EDR Report	PDF
3. Specific EDR Report	PDF
4. Customized Drawing	PDF
5. EBOM PPAP Status Report	PDF
6. EBOM Report	Excel
7. Material Upload Verification	PDF
8. Multilevel EBOM Report	Excel
9. Standard EBOM Report	PDF
10. Standard MEP EBOM Report	PDF
11. Standard Where Used Report	PDF
12. Supplier PPAP Specific Report	PDF
13. Change History Report	Excel
14. External Corporate Directory	Excel
15. Internal Corporate Directory	Excel
16. Part Asset Cost Report	Excel
17. Part Asset Overview Report	Excel
18. Configurable FLAT EBOM Report	Excel
19. Configurable MEP EBOM Report	PDF
20. Configurable Where Used Report	PDF
21. Configurable EBOM Report Classic	PDF

TVC Report Generator - Windows Internet Explorer

TVC Report Generator

Please wait while the report is being created

Report Name	General Description Report (PDF)
Status	In queue
Duration	0 Minutes, 0 Seconds

Cancel

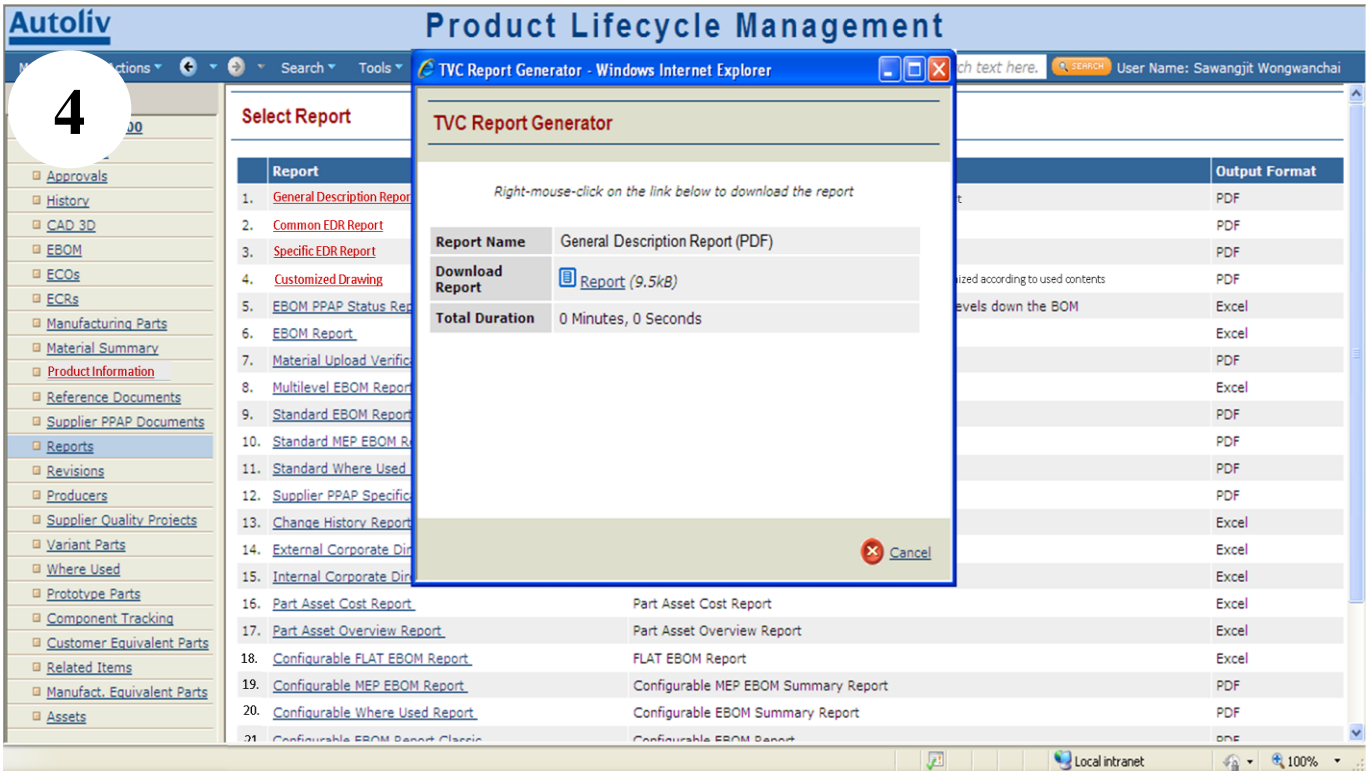
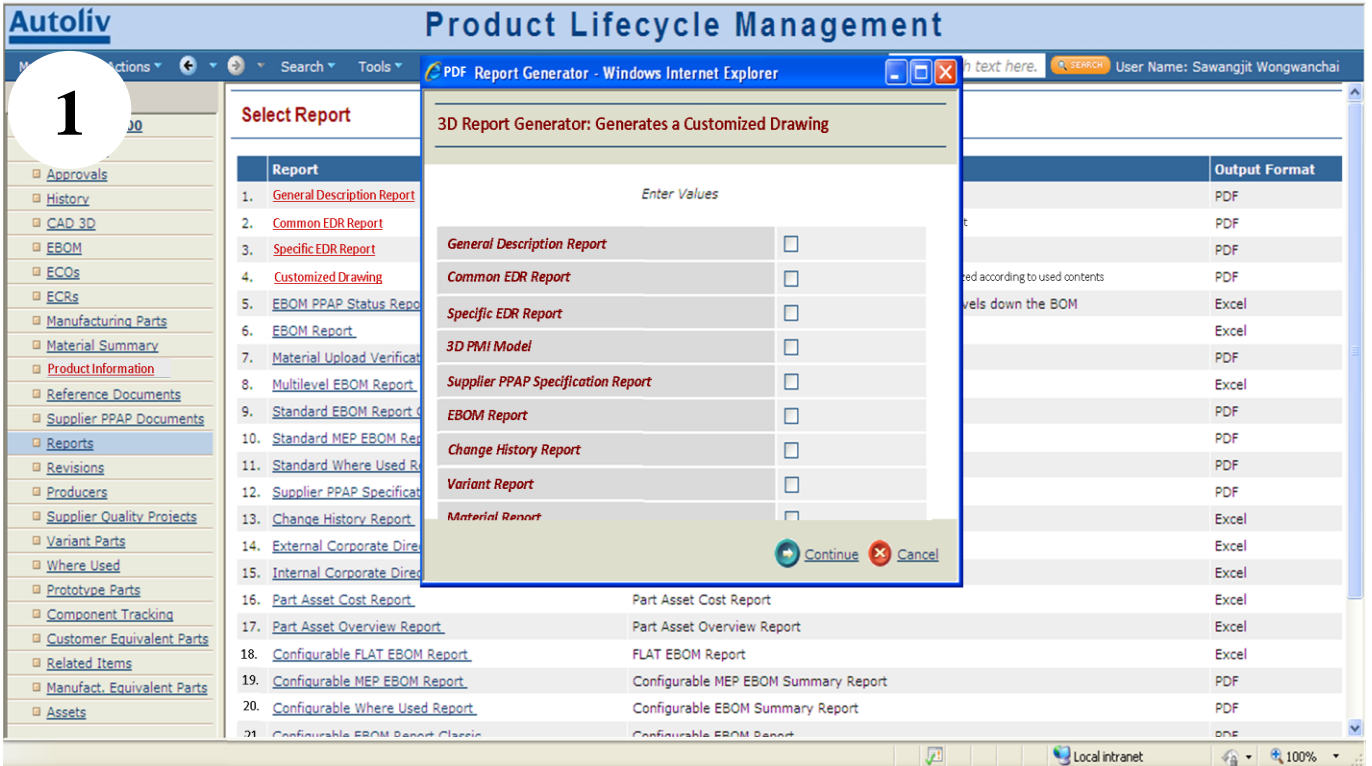
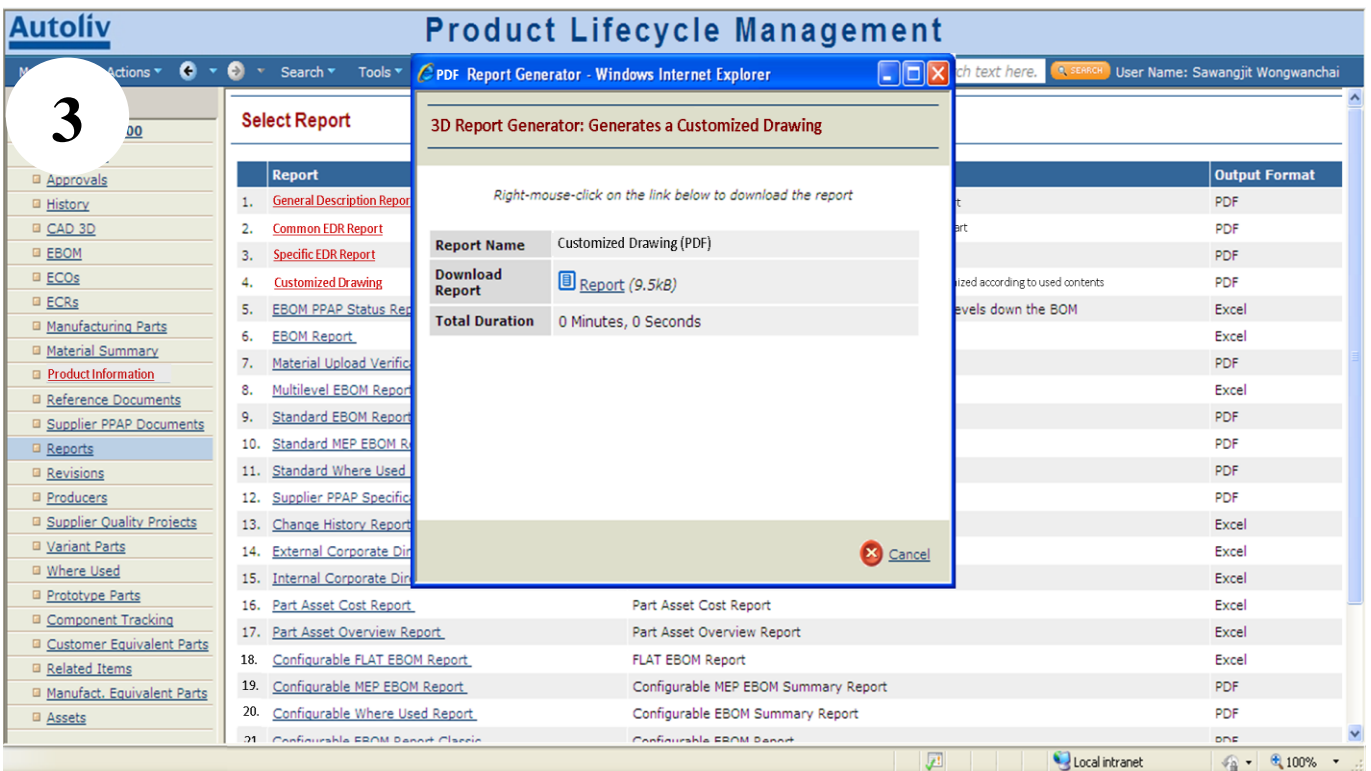
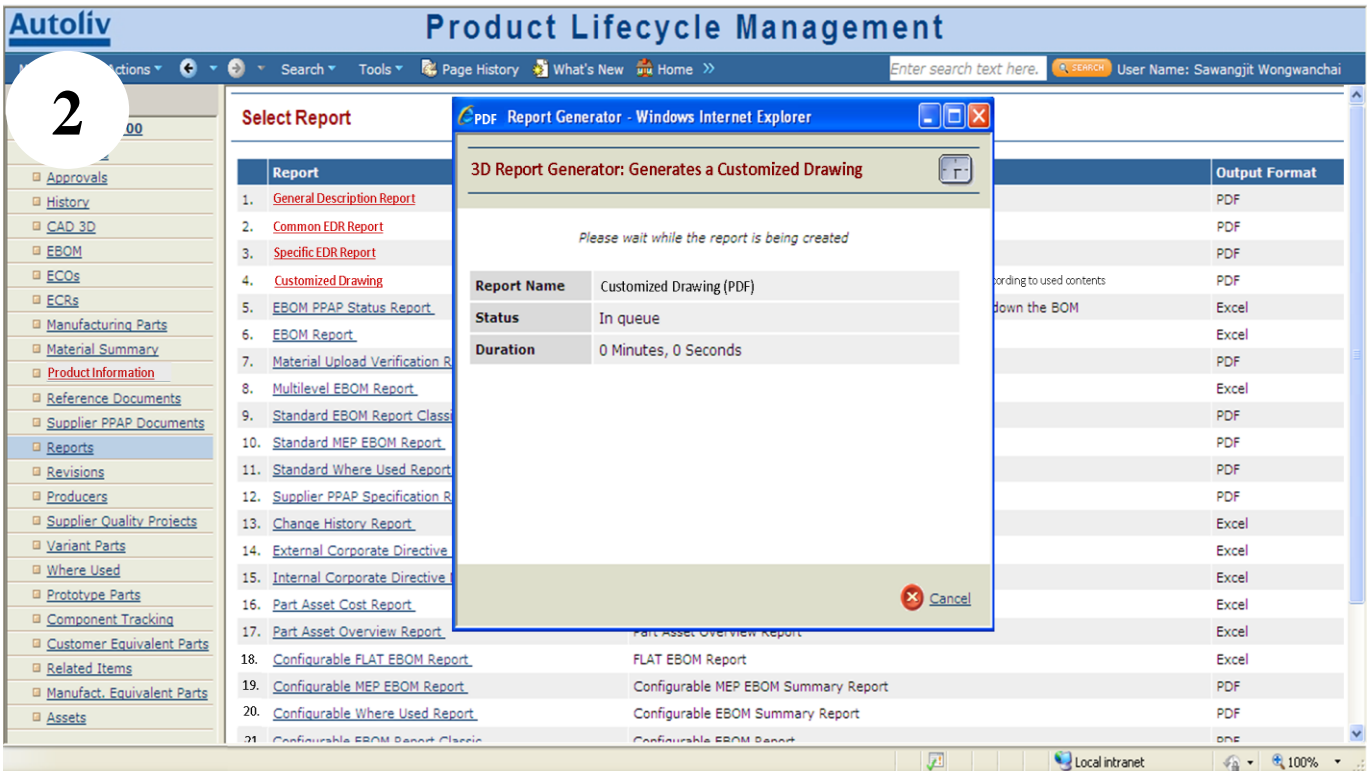

Figure 21: Steps of the process of creating a Customized Drawing





7.1.4 Data exchange format

The neutral data exchange format is a key communication among different operating systems, especially in the multi-CAX system environment, since it can decrease a number of system interfaces. The potential universal 3D data exchange format, able to carry completed geometrical product information and to allow reusing the file with other different CAX systems for diverse purposes such as measurement, analysis, simulation and so on during the

product lifecycle internally and externally, is advantageous in terms of time and cost savings. It, too, is a future requirement, but some general analysis of suggested potential 3D data exchange format will be provided here as input for the future work.

7.1.4.1 Alternative format: There are several kinds of 3D CAD data exchange formats containing STEP, VRML, JT, IGES, STL, and PDF 3D. Below are their short descriptions.

- **STEP** (STandard for the Exchange of Product model data, ISO10303): Only a small part of it **concerns geometry data exchange** but it is supported by most CAD systems. It is described by Mathematical description (Lindkvist, 2009). In this case, STEP AP 203, Configuration controlled 3D designs of mechanical parts and assemblies will be considered.
- **VRML** (Virtual Reality Modeling Language): Language for interactive visual simulations on WWW, which is an open standard. It is also used for geometry data exchange and supported by most CAD systems. Mostly it is used for analysis program such as Robust Design and Tolerance (RD&T). The feature that is commonly used is structured triangulated surface geometry, and it also includes colour, material, and textures, among other things. It is described by a triangulated (Lindkvist, 2009).
- **JT** (Jupiter): It is a neutral file format from Siemens (UGS) and supported by all UGS products (and also many others). A translator module is required to make CATIA V5 understand. It used to be a closed format but now the specification is released to the public. The features that are commonly used are Trimmed parametric and Triangulated surfaces. It is most widely used as a standard for geometry data exchange nowadays due to its lightest format. It is described by Mathematical description and Triangulated format (Lindkvist, 2009).
- **IGES** (Initial Graphics Exchange Specification): It is ANSI standard since 1980 that is supported by most CAD and CAx software. Most CAD-system exports solid geometry as trimmed parametric surfaces. However, it is an old fashion format. It is described by Mathematical description (Lindkvist, 2009).
- **STL** (STereo Lithography): It is widely used for rapid prototyping and scanning, and is supported by most CAD systems. It is used to describe the boundary surface of a 3D object with triangles, and no other information. It is described by triangulated format (Lindkvist, 2009).
- **PDF 3D:** It is a combination of two main formats:
 - **PRC** (Product Representation Compact): It is a 3D file format capable of representation 3D files in PDF form, developed by Adobe. Both exact and tessellated geometry representation are presented in PRC. There are several levels of compression to be chosen. High compression allows for a very small file size, one of the interesting advantages. PRC is proceeding towards being included in the PDF/E ISO standard (Adobe, 2008).
 - **U3D** (Universal 3D): A major characteristic of the format is a standard compressed format for 3D data developed by several 3D users from diverse industries. U3D enables tessellated geometry representation. It belonged to the ISO PDF/E International standard (Wikipedia, 2011d).

It is clear that VRML and STL are of less interest since their major applications are for analysis program and rapid prototyping, respectively, and they are not widely used. Also, PRC will not be taken into account further since it is not a standard format. Hence, only STEP, JT, IGES, and U3D will be discussed and analyzed further in detail in Appendix D.2.

7.1.4.2 Selection criteria: The selection criteria for the format are defined below. They are generated based on their potential for and usability in exchanging data.

- **Compression size:** It defines a size of a file format as compared to the amount of information it can carry. The smaller the ratio is, the better the format capability, meaning that the file size is compact. To have a small file size is beneficial but not necessary.
- **Completeness:** It is an ability to carry a variety of geometrical product information, or it can be said to be the potential level to cover all geometrical product information aspects. It is the possibility that the file can be reused throughout the product lifecycle. It is crucial to have complete file information; otherwise, exchanging purposes is meaningless.
- **Usability of file exchanging:** This criterion focuses on the potential of a format that it can perform in file exchanging tasks. It can be measured by considering the main purpose, features, and experiences of the format. Although this criterion is fairly important, it is more than vital that the format must achieve its main criteria.
- **Generalization and Standardization:** It is the degree of the commonality of the format that is widely used by a large number of organizations and industries. It is a publicity level of a format defined by the amount of CAx systems that can understand the format and utilize information. The availability of format viewers and translators in the market are also in consideration. It can be called a degree of format neutralization. This criterion is a major key for information exchange.
- **Continuous improvement:** It is a measure of the modern degree of the format. The format that has been released recently or still under development is a plus. It is important since CAx features of each CAx system are being developed endlessly. Hence, the format should be up-to-date as well. Continuous improvement criteria are important, but they are not necessary as long as the format can still perform well in its core exchanging tasks like generalization and standardization.

7.1.4.3 Selection: The criteria in the previous section have been used as selection criteria for the 3D CAD data exchange format selection by using the Pugh matrices twice for reliability and accuracy of selection. In both matrices, all criteria are weighted according to their significance level as mentioned in Section 7.1.4.2 since all criteria are not equally important. For the first matrix STEP AP 203 was set as a reference meaning that JT and IGES were compared against it. Then, the first rank from the first matrix will be set as a datum in the following second matrix. Both matrices can be found in Appendices E.2 and E.3. It is clear that JT is the greatest potential 3D CAD data exchange format throughout the product lifecycle according to the selection criteria. However, the STEP AP 203 selection score is comparable to JT. Therefore, STEP AP 203 should be considered as an option to implement as well, while both IGES and U3D have inferior capabilities.

7.1.4.4 JT against STEP AP 203: Due to the fairly equivalent selection score between JT and STEP AP 203, they will be compared against the selection criteria.

- **Compression size:** JT is outstanding in this criterion since it is possible to represent approximated or faceted data resulting in a small file size with completed geometrical product information. On the other hand, STEP AP 203 cannot do so.
- **Completeness:** Even though both JT and STEP AP 203 are able to represent NURBS data or rich size data format which contains the greatest possible completed data, JT is still more advanced than STEP AP 203. It is obvious that STEP is possible to represent diverse kinds of information since it consists of several different types of APs. Nevertheless, when comparing JT with the single AP, JT itself has a greater number of information representation varieties compared to STEP that require several APs to be able to represent the same amount of information.
- **Usability of file exchanging:** When comparing JT and STEP AP 203, against each other, STEP itself has a greater potential due to a large number of applications and high level of maturity of the format.
- **Generalization and standardization:** The generalization and standardization degrees of both formats are apparently similar. They are widely used by the public and can be understood by several major CAX systems. On the other hand, both format translators from native CAX system formats are available. In addition, numerous JT and STEP viewers are obtainable as freeware, such as JT2Go for the JT and IDA-STEP for the STEP. STEP became the ISO standard before JT but they both are the ISO standard today.
- **Continuous improvement:** Both formats are still improving. The latest version of JT is Version 9.5, which has been launched recently. For STEP in the Mechanical group, AP 242, which is in the context of 3D Engineering, will be the latest under development.

According to the discussion matrices in Appendices E.2 and E.3, JT is the most optimal 3D CAD data exchange format. JT overcomes STEP AP 203 in Compression size and Completeness criteria. Generalization and Standardization and Continuous improvement criteria are comparable. Although STEP AP 203 is superior to JY in the Usability of file exchanging criterion, JT is better in overall important criteria. Using JT not only provides a possibility to reuse the file internally throughout the whole product lifecycle, but it also allows suppliers to use JT2Go, a JT freeware viewer, to view 3D PMI (Product and Manufacturing Information) model in JT format without any CATIA license required. As mentioned in the beginning of this section, this analysis will be input for a future work. Therefore, the format feasibility to overall CAX applications that JT will use as the data exchange format must be analyzed in further detail, since the criteria above are general criteria for the potential formats.

7.1.5 Customized drawing

Customized Drawing is a new type of drawing resulting from an introduction of a new CAD-PLM suggested solution system. It combines all the necessary information from the PLM database and the 3D PMI CAD model that contains GD&T information according to user's

requests. The performance of the new system provides users various options when choosing information and documents that is necessary and should be included in their works. The appearance of the customized drawing can be seen in Figure 22.

7.1.5.1 Content in the customized drawing: The content below defined the content in the customized drawing from PLM and 3D model sources.

- From PLM:
 - Note texts from new EDR. They are from the Quantitative detail and Property description groups.
 - Quantitative detail includes 1.3.2 Technical information
 - Property description includes 1.3.1 Part/product definition: b) Part/product type, 1.3.1 Part/product definition: d) Surface and texture, 1.3.1 Part/product definition: h) Traceability level accd. to AS 4, 1.3.2 Technical information, 1.3.3 Standard part/product, and 1.3.4 Product certification/approval
 - Note texts from classification criteria that are not located in EDR. They are in the Textual description group, including 1.3.1 Part/Product definition: e) Quality requirement, 1.3.5 External requirement fulfillment, 2. Manufacturing information and Technique, and 3. Verification requirements.
 - ECR history with versions and revision history (existing object)
 - Part/Product identification information, such as Name of the part, Part number, Traceability, etc. (existing object)
 - Other associated documents

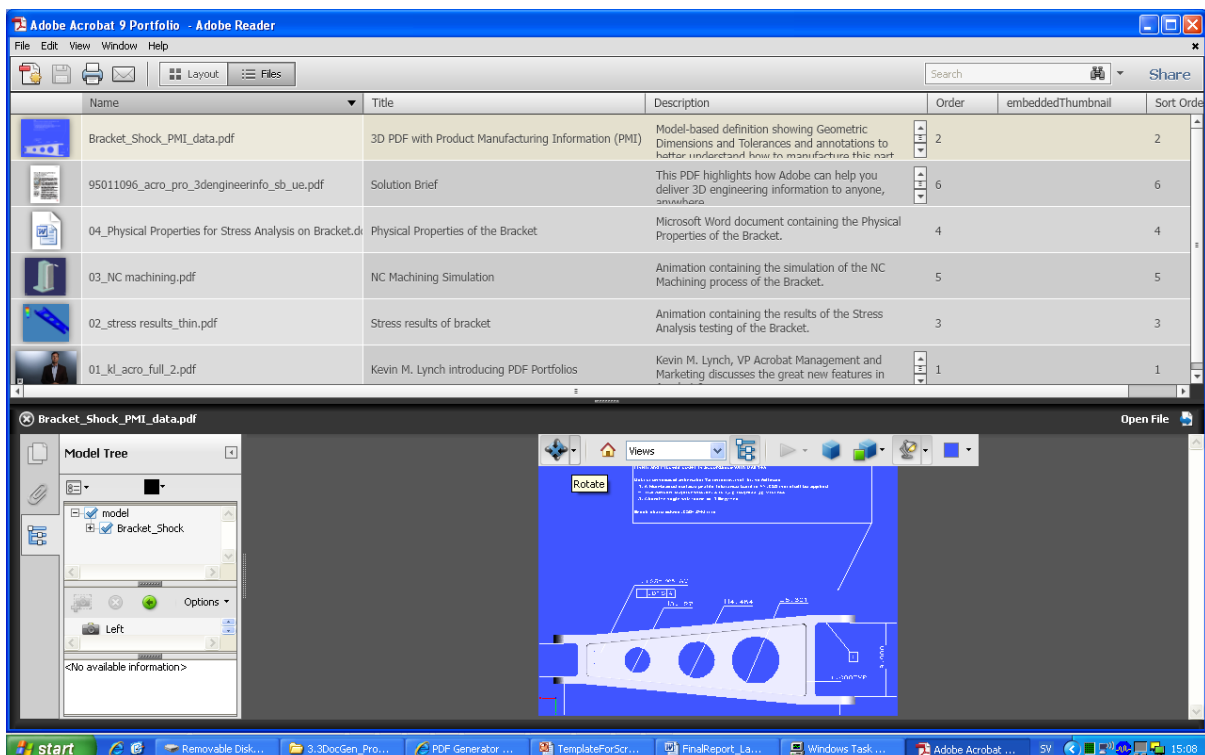

Figure 22: An example of a customized drawing or intelligent PDF file: The CAD file of this document package originates from CATIA V5 as 3D PMI (ProSTEP, 2011).

- From CATIA V5:
 - A 3D model
 - Tolerances in a 3D model
 - Dimensions in a 3D model
 - Any kinds of feature illustration
- From other generated documents: This document will be created in CATIA and then checked in into PLM ready to be combined in the customized drawing.
 - 1.3.6 Marking and printing notes (such as text labeling) on a part, such as how to print some specific text on the part according to customers.

7.1.6 Holistic view of the suggested CAD-PLM system

Figure 23 illustrates the holistic view of suggested CAD-PLM system with some changes in user roles. When the 2D drawing is removed due to the introduction of the new system, some routine works from each user will be adapted. In the PLM system, the ProSTEP 3D generator will be introduced to convert the 3D CAD file into a 3D PDF to be merged with existing selected documents in PLM. The final document package can be read by Adobe reader Version 9 and later. The new system makes CAD and PLM more tightly integrated by sharing product information together and providing intense collaborations between the two.

7.1.6.1 Change lists

- **CATIA V5:** Utilize FTA module in Production
- **PLM:** Some user interfaces are changed as stated above in Sections 7.1.1.2 and 7.1.3.2.

User roles in suggested CAX-PLM system

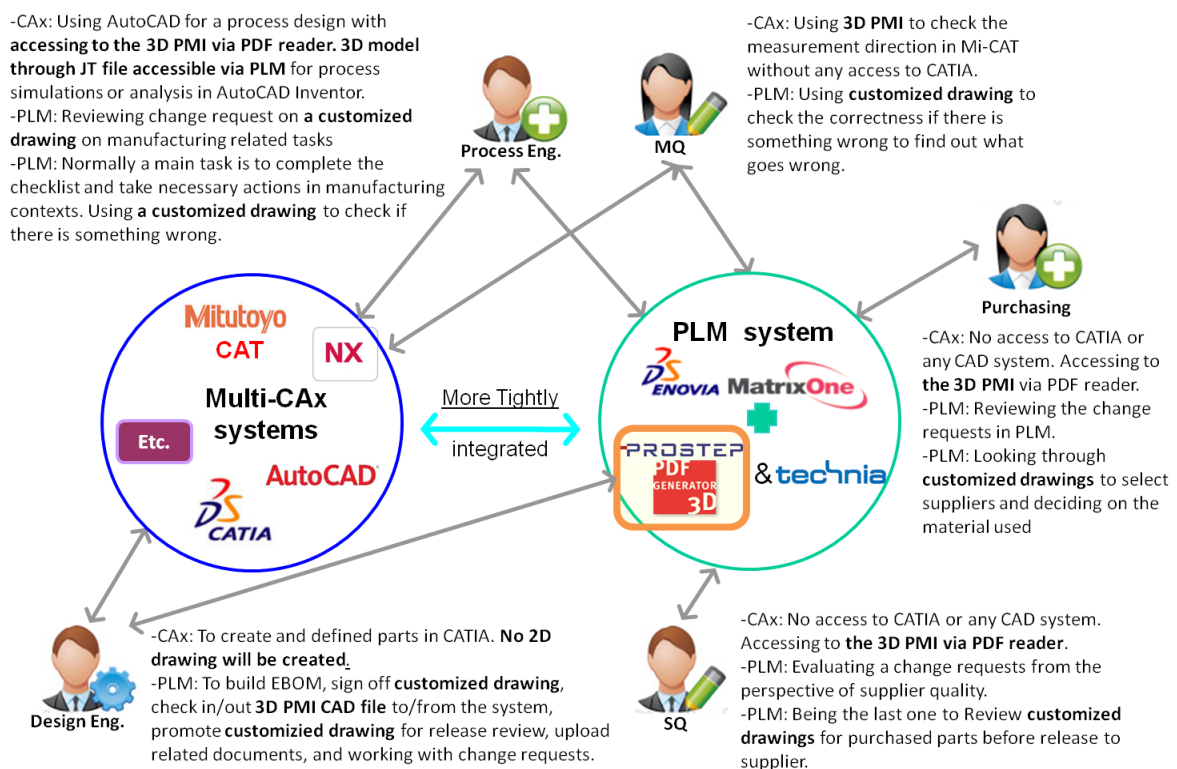

Figure 23: Holistic view of suggested CAD-PLM system with its user roles

- **Document generator:** Some components of ProSTEP 3D Generator will be integrated into the PLM system.
- **Document:** The 2D drawing will be removed, and the Customized drawing will be replaced.
- **3D model:** Changed from the original 3D model to the 3D PMI model (the 3D model with GD&T information) in CATIA V5 format and JT format.
- **Users' roles:** Changed according to bold texts in Figure 23.

7.1.6.2 Overall working procedure for the suggested system: The working procedure for the overall system is the 3D model with PMI information. It will be created in CATIA V5 format, and it will be converted into the JT format. Both will be checked in separately into the PLM system under the CAD 3D class. CATIA V5 will be opened in the CATIA V5 workstation while JT will be reused in the other CAx workstation. Product information that belongs to any three product information classes, mentioned in the information model in Section 7.1.1.1, will be added to and displayed in PLM. There is a possibility to generate a single 3D PDF document package, a customized drawing that contains product information, other related information from PLM system and geometrical product information in CATIA V5 format. Also, there is an option to customize before creating the document package. The report generator components consist of a ProSTEP CAx translator module, a ProSTEP PLM Connector, ProSTEP Base Server Component, and an existing Technia Report Generator. The overall working procedure of the suggested system is clarified in Figure 24. The functions of the three ProSTEP components are described below.

- The Base server component is required for gathering all data and file into the single document package.
- CAx translators from ProSTEP 3D generator are required for the system to convert a 3D model to a 3D PDF with PMI information.
- PLM connectors is used to transfer any file and metadata from PLM system including the file generated by Technia report generator to Base server component which will be combined with the PDF 3D model into a defined template resulting in the 3D PDF document package.

7.2 System evaluation

It is important to compare the suggested system with existing systems currently utilized. By doing so, one can learn from others' experiences and receive feedback from end-users for further system improvement and system fault prevention.

7.2.1 Benchmarking with the case studies

Case studies: Volvo Car Corporation and Diamler are used as references for benchmarking to assess the suggested system since they have implemented the 3D Master Concept before.

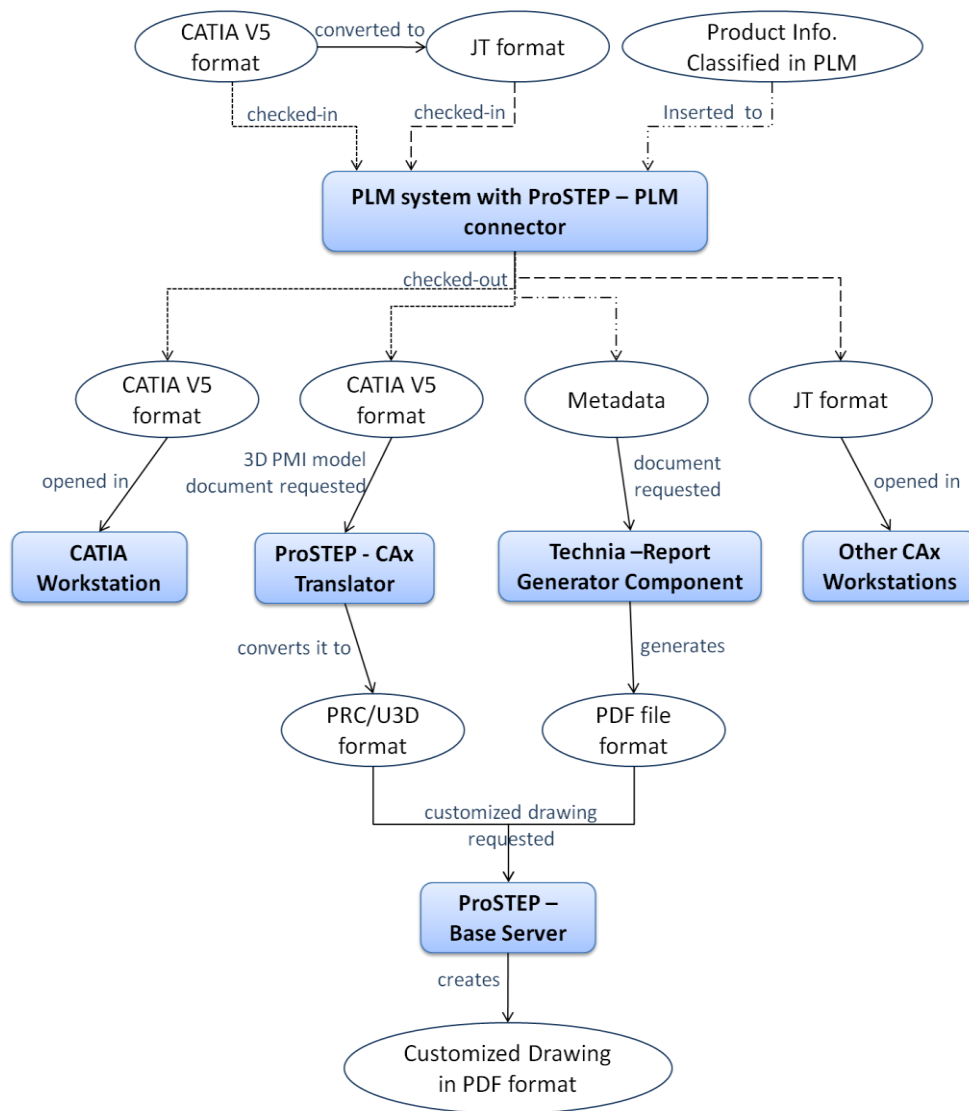

Figure 24: Overall working procedure of the suggested system

- Volvo Car Corporation (VCC):** VCC has implemented the 3D Master Concept for a while but the exact time is not known to author. They started the concept with a sheet metal part since it was less complicated and simplest to apply. However, they have plans to utilize the concept with other parts in the near future. The next part will be a plastic part. The PDM system at VCC is Teamcenter Engineering (TCE) from Siemens with KDP developed by VCC as scripts as a PLM system. The multi-CAD system at VCC includes CATIA V4, CATIA V5, and IDS, but the main use is CATIA V5 R18 sp4. They put the 3D master concept into practice by locating all the product information on the 3D PMI model, including the note texts. The note texts are pre-defined as a template and placed at a zero coordinate reference to a whole car. A template only applies only to one kind of part. With this execution, a 2D component drawing on a sheet metal part is of no use. However, a 2D assembly drawing is used since other related parts do not have a 3D PMI model. The FTA module added on CATIA V5 is an application tool to achieve the concept since it provides a possibility to position product information in a 3D model. Teamcenter Visualization (TCVis) is a viewing tool embedded in their PLM system used

to view 3D PMI models without any CAD system required. Since JT is the major 3D PMI model format, their suppliers may use JT2Go to view the model. The interview transcription is in Appendix A.3.

- **Daimler:** Daimler has also utilized 3D master concept for some time. Their main CAD system is CATIA V5, and the PLM system is also TCE. With this concept, the 3D PMI model is utilized throughout the product lifecycle without any 2D drawing. JT is used as a data representation of 3D PMI CAD data at Daimler. Even Long Term Data Archiving is still based on TIFF (Tagged-Image File Format). According to ISO, TIFF is a media-independent means for prepress electronic data exchange. However, they plan to base all data on 3D PMI CAD in the form of JT in the future. Once the CATIA 3D PMI model is checked-in, it is automatically converted to JT and stored in the Daimler EDR system. That system is available to use for all applications including web-based access portal, client access, data exchange, and virtual reality applications. Daimler also has the goal of providing simplicity: a button is used in all relevant Daimler applications to visualize parts. To view the 3D PMI model, a visualization tool is a main key to enable the sharing of the product information. The 3D PMI model in JT format is viewed and interacted with, through VisBasic and VisView Pro PMI embedded in the PLM system, for example. At the moment, internal and external users are getting used to the 3D master concept measured by a number of users that call for or use visualization tools. Also, supplier may access 3D information in a controlled way. There are four different levels of user controls to limit supplier access to the Daimler portal; for example, level 1 is opened for every supplier (Klass, 2008; Klass, 2006). However, Daimler might change their major CAD system from CATIA to Siemens. This would allow them to rely on one single system to utilize the 3D master concept with full capability and further development with Siemens.

Discussion: According to the cases study from VCC and Daimler, there are some features that the suggested system could improve. They are as follows:

- **Visualization system embedded in PLM system:** For better product information illustration, having a visualization system that is able to dynamically interact with a 3D model in the PLM system, similar to working on a CAD system, is advantageous. In addition, the tool also provides functions to manage 3D models according to users' purposes, giving more flexibility to users.
- **Note template:** It is simpler and more convenient for information creators and consumers to provide note templates for different kinds of parts. For information creators, note text templates support them by cutting the number of their workloads and reducing searching time for notes in previous drawings, resulting in shorter lead time. For the information consumers, note templates provide the same understanding and avoid confusion for the readers. That is because without the templates, the different creators may use different words and ways of writing, leading to chances for misunderstanding. Using the templates is one way to standardize notes. The concept is applicable to the suggested system by creating a note template for an individual part in the PLM system.

- **Automatically convert the 3D model to JT when checked in:** This automatically JT-converting concept could be used with the neutral exchange format, JT of the suggested system. The reason is that an information creator is currently assigned to translate a native 3D CAD model to JT and to check both native and converted model in manually. This feature will reduce the amount of information creator tasks and prevent human error in dealing with a converted model.
- **3D master system supplier control:** Using the 3D master concept is obviously done in the digital world. Therefore, providing an external user control is crucial to limiting the access of users for the security of the firm and protecting confidential data from being misused.

7.2.2 Feedback from the users

The information owners and users were shown screenshots of the suggested system with some system descriptions before being asked to provide feedback.

Users' feedback on the system: The user feedback is categorized into five groups: General comment, Product information page, Report generator – customization, 3D model, and 2D drawing. The analysis feedback table (with users' functions) is shown in Appendix A.4. The feedback conclusions from the table are clarified below.

- **General comments:** It is an interesting system, and the overall system seems to be good and support the users' works because all the information is still maintained and it is easier to use. A better judgment could be given after one has tried and gotten more familiar with the suggested system since it is simpler to comment after one has been working with the system for a while.
- **Product information page:** It is good that all notes are managed and classified in PLM system and associated document links are provided since there is no need to search for the documents. Also, a note browsing function is seen as a benefit.
- **Report generator:** The report generator customization function is a great function since it is helpful to pick what you want.
- **3D PMI model:** The 3D PMI model shows clearer geometrical product information, as a large number of explanations are required in creating 2D drawings to express additional information for manufacturing departments and suppliers. It is also great for flexibility to choose a projection view of a 3D model and have the possibility to print the document for shop-floor people.
- **3D CAD data exchange format:** The availability of a potentially neutral 3D CAD format that can preserve all the necessary geometrical information from its native 3D CAD file in the PLM system is valuable and supportive. It saves file conversion time and supports process simulations in manufacturing and measuring processes in MQ.
- **2D drawing removal:** A current drawing is easier for the users since currently drawing is a single document. The suggested system is seen to include more works to click, and it could lead to a risk of missing some necessary information.

Suggestions regarding the suggested system: The users also suggested some improvement in the purposed system. They are classified into seven groups: General

function, Product information page, Report generator, Training, Implementation related, Risk, and Further analysis. The suggestion classified table with user's functions is presented in Appendix A.5. The suggestions for further improvement conclusions from the table are clarified below.

- **General function:** There are two main things here. In the PLM system interface, favorite user settings should interface for each user. In an assembly model, it should be able to display only dimensions and tolerances related to assembly and hide all individual dimensions of a part to avoid confusion.
- **Product information page:** There are several comments related to a note and a product information function. First, three categories of notes should be located in different pages under the product information group. Second, a note template for each type of a part to standardize notes and to reduce ambiguity and possibility to write extra note and the reference number in front of a note should be updated automatically. Third, there should be options for selecting the number of notes per a page, so people do not need to scroll down too much. Fourth, a function to create shortcuts for some specific group of notes should be provided allowing PLM user interface customization. Fifth, the attachment of associated documents to notes should be set as a mandatory activity that an information creator must perform before proceeding to the next step. Sixth and last, the possibilities to share testing results from a part in the PLM, instead of manually sending emails, will be great for MQ.
- **Report generator:** In the four new report generator options in the report page, different pre-defined selections of necessary note groups or documents specific for a user's function should be provided to avoid information missing and miscommunication. For internal users, the complete level of selections (without any limitation) should be available for all internal users. The flexibility to select could be separated between external and internal users. There should be pre-defined mandatory content selections included in the report generator option pages, as there is a risk that suppliers could miss something for external users while the system could provide more freedom to select for internal users. It will be convenient to be able to include a testing result of a part into a customized drawing.
- **3D CAD data exchange format:** In using the neutral 3D CAD model, it would be good to also consider 'workshop.' It is a section for making a particular tool to support the production line and testing upon request. This allows the users to utilize this 3D model with complete information to design and build precise and accurate tools. In addition, it is important to ensure that the chosen neutral 3D CAD model can provide complete product information in other CAx systems. That is because current STEP files cannot represent GD&T information.
- **Training:** Training is required for both internal users and suppliers. A workshop for Autoliv's suppliers to introduce how to use new features of the system must be arranged to provide a clear understanding for external users.
- **Implementation related:** Diverse suggestions related to the implementation are listed below.

- The time required to make the suggested system work in practice needs to be considered by comparing it with the time frame of new advanced CAD and PLM system technology and defining the return of investments.
- New Autoliv standard documents, related to contexts of how to create 3D drawings or 3D PMI models, must be formulated.
- Before the system implementation is in production, the system should be stable and users must see and use PLM as a main center.
- A suggestion forum for internal and external users could help to give feedback for directly improving and debugging the system.
- The 3D master concept should be started with Die casting suppliers supplying the implementation, not uncomplicated part-suppliers. Simple part-suppliers do not have as much experience working on 3D models as Die casting suppliers.
- Connect the DVM system, which is an additional parallel system to the PLM system storing all the information related to testing, to the PLM system in order to have PLM single access for all information.
- **Risk:** There are two kinds of risks analyzed by the users. The first one is a security risk. With this 3D master concept, there is a security risk that suppliers could steal confidential information from the PLM system. Thus, Autoliv needs to make sure that the current PLM system can guarantee data security. The second one is a customization risk, a risk that the supplier does not select all necessary notes/documents, resulting in information missing and miscommunication. SQ could pre-select the important item for suppliers.

7.2.3 Suggestions method to reduce change resistance

The descriptions are the suggestions for how reduce change resistance and make people get used to the system changed. The suggestions (below) are recommended by the system users from several functions at Autoliv and the VCC interviewee. The interview transcription can be found in Appendix A.6.

- Point out benefits for all related functions (including Engineering, Manufacturing, MQ, and SQ) to reduce change resistance and to make it easy for suggested system changes.
- Provide information for the suggested system users to avoid conflicts.
- Set a test group of people who have negative feedback regarding the suggested system and provide presentations to make them get used to the system and to increase acceptance level.
- Train and introduce new methods to make people get used to the system.
- Impress people by debugging the suggested system before introducing it in practice.
- Set the trial system or live test system in PLM for the users to test and play around with to explain the reasons for changes.
- For someone who still wants a 2D drawing, there is a function to create a 2D drawing from 3D PMI. They need to create it themselves however.

Chapter 8

Discussion

The chapter discusses how the thesis fulfills the goal and answers the research questions in Chapter 1, reflects on the system's validity, and generalizes about the applicability of the system to other companies. Each topic will be addressed as follows.

8.1 Reflection on the system solution

The suggested system is good, and the most appropriate one, at least for now. That is because the goal of this thesis is achieved by delivering all the tasks stated in the goal statement in Section 1.6, the results are able to answer the research questions in Section 1.7, and most stated requirements in Chapter 6 are fulfilled by the suggested system. The system responds to the research questions as follows. First, product information regarding Autoliv's product drawings and its owners and users are identified and classified in Chapter 4. After that, the interviews and system capability studies in Chapter 5 are used to formulate the requirements' on the new system in Chapter 6. Next, the product information is mostly an engineering note that is relocated into the product information page in the PLM system, while the rest (mostly GD&T information) is more appropriate to be placed in the 3D model. Finally, the product information from the PLM and 3D model is merged by using the report generator function to create 3D PDF documents or a customized drawing. In addition, a suitable 3D CAD data exchange format is also recommended from the analysis results in Chapter 7. The fulfillment level of each established requirement can be seen in the last column of the requirement table, Table 2. The system's advantages and disadvantages are summarized in terms of time, cost, and quality in Table 4.

8.2 Implementation suggestion

The suggested system concept is analyzed based on literature studies and information from interviews. Accordingly, there are some other factors that need to be considered, studies and tests before the execution in production. First, the feasibility of practical implementation is required to be studied. Also, the existing change management process needs to be seriously taken into account for the change of the 3D PMI model and product information in PLM system. It is possible that the system seems to work well in theoretical but some hidden problems may occur in reality. The assessment of the time required for the suggested system development is a crucial issue to be concerned with as mentioned in the Delivery requirement in Table 2. The suggested system is excellent for the current CAD-PLM system at present and in the near future, but it will not be the most suitable system forever. The CAD-PLM system could be changed and some other needs and requirements might come to play more important roles in the future than the existing requirements do now. Therefore, its development time should be in an acceptable range in terms of cost and quality. Next, the risk analysis of the suggested system, as compared with the current system, must be performed. The possibility of product information customization, a main feature of the suggested system, is seen as a benefit- a risk. It could lead to a miscommunication risk and a security risk. A

miscommunication risk could arise if the product information users do not select all the necessary product information. However, this risk can be managed by training the users, arranging the users' workshops, providing pre-defined mandatory selections for some users, and so on. A security and risk is a risk of information theft and misuse by external users

Table 4: Advantages and Disadvantages of the suggested system

Advantages	Disadvantages
Time	
Faster to search for and find interesting information and associated documents	The suggested system development could take a long time.
Shorter lead time	It could take some time to make people accept the changes.
Cost	
Saving cost of engineering hours that the system users spend on searching and communicate to get the right information.	The system development cost and the investment on suggested technology could be high.
Cost of using the wrong information will be reduced since information is in one place and reliable.	FTA training costs are required.
No cost on viewing system.	
Quality	
Error reduction: In customized drawing, it illustrates where exactly the GD&T note indicates in 3D PMI model and provides a possibility to interact such as rotating and enlarging the model which enriches information communication and reduces information ambiguity.	Fully relying on the PLM system could be risky if the system is not stable and reliable.
The PLM central: Accessible to product information related to user's context in one place and one document package including required information by using the document generation function. Possible to have different kinds of documents in a single document package. Accessible to neutral 3D model.	There is a chance of risk in terms of information security.
User friendly: Provides integrated viewer of 3D PMI model. Possible to customize information with just a few simple steps before creating a document.	Risk to receive incomplete information is possible.
Reliable information: Because information is located at one place, consistent and correct information is available.	-

because customization and flexibility allows them to get closer to the company information. The way to minimize this risk should be in very much concern as theft and misuse could negatively affect the firm. One alternative suggestion is to exclude external users from flexibility and customization functions by choosing and providing limited right of access for them and also to use an element from Adobe Lifecycle components to control the security of the PDF document package.

8.3 Generalization and standardization of the suggested solution

According to the suggested system, some elements of it could be implemented at other companies as well. The concept of managing product information notes in the PLM system and providing a browsing function for the notes could be applied to other companies by adjusting the concept to suit a company PLM system. Secondly, placing GD&T information in a 3D model by using FTA is a general concept that is useable by any companies as the FTA module from Dassault is available in the market. However, the customized drawing concept is fairly specific for Autoliv because it results from locating product information in different places – the PLM system and a 3D model. Then, some method to combined product information in a single place is defined. However, the idea of providing a package of paper documents for shop-floor workers and the users in a computer non-accessible area is definitely applied to other cases. Finally, although most companies use JT as a 3D CAD format (VCC and Daimler, for instance), it might not be the best 3D CAD format for every company. Each company should analyze whether to use JT in this manner based upon its working context and also consider own business needs and process.

It can be concluded from the above discussion that the suggested system is good and appropriate for the current CAD-PLM system situation. Although there are some additional tasks required to be accomplished and some issues to be solved, but they are not difficult to achieve in light of the benefits the suggested system may offer. Finally, the generalization degree of the suggested system is fairly high as several elements could be used by other firms.

Chapter 9

Future Implementation Recommendations

The suggested system can be implemented successfully in practice, according to the gap analysis provided below. Furthermore, some further recommendations regarding additional work to be performed that can enhance the system's capability will be made.

9.1 Gap analysis and recommendations

Some tasks need to be worked on and optimized in order to implement the suggested system. There is room for development. The implementation is divided into two major sides – system and human resources.

9.1.1 System side

PLM system: The PLM system developer teams need to make changes in the PLM system according to information model to make it realistic and to adjust the final appearances of the PLM user interface to make them similar to the suggested ones.

- **Notes in the PLM system:** The technical procedure to implement the notes in the PLM system must be defined in detail. However, the methodology should be similar to a method of inserting other kinds of information into PLM, such as the method of EDR. Gap analysis of each type of note is stated below.
 - **Common notes:** Common notes that are shared among every parts/products are Generic description notes and Common EDR notes. Both can be implemented right away without any additional study.
 - **Specific notes:** Every part has particular attributes that are different from those of other parts. These different notes are grouped under Specific EDR, which is specific for certain types of parts. Hence, further study on Specific EDR is necessary to identify particular characteristics of EDR for each part.
- **Report class:** Four more report generator options described on Section 7.1.3.2 must be added to the report class.
- **CAD 3D class:** Enables the system to upload the JT CAD model, an additional separate file from the CATIA 3D model.
- **Report generator:** ProSTEP 3D generator is suggested to be used along with existing Technia report generator in the purposed system. For the Adobe Lifecycle module, it is an optional application to support the security of the document, to provide electronic signature, and so on. However, the feasibility and compatibility testing of these two systems need to be verified before any investments or implementations are made. In addition, a standard form for each document type needs to be defined before the system is launched.
- **Data exchange format:** Ensure that the chosen neutral 3D CAD data exchange format can provide complete product information for the uses of other CAx systems since currently the STEP AP file cannot carry GD&T information.

- **Change management:** The change management process is an important process to control changes in product development. Product information of a part must be controlled by the change management process. According to the suggested system, any notes in the product information class are able to be updated by using edit function. They are not, however, in the change control. Hence, some solutions that could handle this should be discovered before using the suggested system in practice. The product information notes and 3D model of a part could together follow the existing 2D drawing change management process since some product information from the current 2D drawing in the suggested system in the suggested system is located in the 3D model and the rest is in the PLM. Also, to use the benefit of information management provided by the suggested system, product information could be classified into two types – information controlled by the change management process and information that can be changed without any control.
- **Legacy data:** Legacy data cannot be ignored, even if it is not used. The suggested system might be applicable to some legacy electronic documents in the system, especially from CATIA V4. In order to use these documents with the system, some further investigation on the feasibilities and compatibilities of the system to the documents (and vice versa) are required to be conducted.

CAD system: The JT recommended as the most potential exchange format is analyzed by using general criteria. Therefore, further studies concerning format capability and feasibility as regards the overall CAx systems at Autoliv are required in detail to ensure that the JT can convey complete information from the CATIA to other CAx systems.

Documentation: New Autoliv standard rules for creating 3D drawings without any 2D drawings involved need to be set. Also, the suggested system information and concept should be provided on Autoliv's PLM wiki page. Most importantly, the software requirement document that describes the system for system developers should be provided. This report is good input for the document.

9.1.2 Human resources side

Training: There are two types of important training, system training and CATIA training.

- **System training:** Its purposes are to introduce changes, new ways of working and new suggested systems and also to point out the reasons for and the benefits of changes to reduce change resistance and to increase user acceptance.
- **CATIA training:** Training regarding how to use FTA in production to create 3D drawings according to set standard is mandatory.

9.2 Further recommendations

The first step is to complete the AD, the VaI, and the undone status of ‘demand’ requirements and probably ‘wish’ ones as well in the requirements table, Table 2. Note that this thesis report could be used as the input for the software requirement document in the Document requirement. The next step is to follow the comments and suggestions from the users, such as creating an automatic note template as suggested in the Section 7.2.2. According to the case

study analysis in Section 7.2.1, a potential embedded viewer tool could be defined and utilized to provide greater flexibility to manage and interact with the 3D PMI model inside the PLM system. A further step is to find the method to connect the PLM system to important analysis and simulation applications from both upstream and downstream to enhance PLM usability as a centre and the users' convenience.

Finally, the above recommendations will not only provide the future road map for the system solution, but also support 3D master concepts so that they may work even better. In addition, other suggestions worth proposing may arise after the suggested system has been used for a while.

Chapter 10

Conclusion

The ultimate goal of the thesis is to provide the requirement definitions and to suggest a system solution for the 3D master concept for Autoliv. Even the aim of the work is to be implemented globally. However, the sources of the data collection came from Autoliv and local people in Vårgårda, Sweden with some further suggestions and assistance from people at Autoliv Germany, France, and USA.

Autoliv's current CAD-PLM system has two problem areas. The first is a major problem relevant to product information management. The thesis focuses on product information in 2D drawings. They are super drawings, since all the information throughout the product lifecycle related to a part and product is found there. The second is a limitation in sharing and reusing complete contents on CATIA 3D model. Relocating information on 2D drawings either to PLM or 3D models is seen as the first step to solving the current problem and to implementing the 3D master concept as a concept for future solutions.

After information on 2D drawings was collected and the eight interviews were conducted to verify gathered information and to collect needs and problems further from company document studies and system capability studies, requirements for the changes were formulated. Then, the suggested system was purposed based on the requirements. The suggested system solution for Autoliv is divided into four main sub-solutions. The first piece is the solution of the product information that will be located on the PLM e-part page. The second piece is the solution of the information that will be positioned in the 3D model. The next element is the document generation solution and customized drawing concepts. The last component is the recommendation of the potential neutral 3D CAD data exchange format. Then, system evaluations and further suggestions for system improvement are also provided. They come from the system users and the benchmarking discussion of the case studies made to validate and verify the suggested system.

Finally, the overall system is good theoretically since it responds to the requirements and solves the problems in a great extent. Autoliv can implement the solution by following the provided suggestions and recommendations in Gap analysis and Future Implementation Recommendations in Chapter 9. In addition, some sub-solutions are applicable to other, similar organizations, as mentioned in Section 8.3. In the past, a conventional paper-based 2D drawing and blueprints were used. Then, product information was shifted to being presented in the form of an electronic 2D drawing, along with associated 3D model created using CAD technology. In the near future, the 3D model will play a major role presenting the information alone. This will result in a complete move of mastery on 3D data and the total elimination of 2D drawings. People will be able to share and use the completed information with less effort.

References

- Adobe (2008) *PRC Format Specification*, [Online], Available: http://livedocs.adobe.com/acrobat_sdk/9/Acrobat9_HTMLHelp/API_References/PRCReference/PRC_Format_Specification/ [2011].
- Alange, S. (2009) *The Affinity-Interrelationship Method AIM*, Gothenburg: Chalmers University of Technology - Total Quality Management course material.
- Almefelt, L. (2010) *Requirements Management*, Gothenburg: Chalmers University of Technology - Product Development Project course material.
- Appleby, J. and Dahlén, M. (2006) *Autoliv Inc. Standard, Part Number - AS 101*, Autoliv - internal document unpublished.
- AutolivCAD-PLMTeam (2006a) *PLM Concepts*, Autoliv- internal document, unpublished.
- AutolivCAD-PLMTeam (2006b) *PLM Training Introduction to Change Management-CATIA V5/PLM Method Training handout*, Autoliv - internal document, unpublished.
- AutolivCAD-PLMTeam (2008) *Managing Change Orders (ECO/MCO) - CATIA V5/PLM Method Training handout*, Autoliv - internal document, unpublished.
- AutolivCAD-PLMTeam (2009) *Overview of PLM for Designers-CATIA V5/PLM Method Training handout*, Autoliv - internal document, unpublished.
- AutolivCAD-PLMTeam (2009b) *CATIA-PLM integration - CATIA V5 Method handout*, Autoliv - internal document, unpublished.
- AutomotiveIT-International (2011) *JT data format closer to becoming international standard*, [Online], Available: <http://www.automotiveit.com/jt-data-format-closer-to-becoming-international-standard/news/id-001471> [May 2011].
- Bergman, B. and Klefsjo, B. (2010) *Quality from Customer Needs to Customer Satisfaction*, 3rd edition, Lund: Studentlitteratur AB.
- Briggs, D. and Hendrix, T. (2006) *AP203 Edition 2 - Configuration Controlled 3D Design of Mechanical Parts and Assemblies*, Boeing.
- Burr, H., Deubel, T., Vielhaber, M., Haasis, S. and Weber, C. (2003) 'Challenges for CAx and EDM in an International Automotive Company', Stockholm.
- Butcher, R. and Dahlén, M. (2004) *Autoliv Inc. Standard, The use of CAD data in PDM - AS 102*, Autoliv - internal document, unpublished.
- Chakrabarti, A.K., Feineman, S. and Fuentesvilla, W. (1983) 'Characteristics of sources, channels, and contents for scientific and technical information systems in industrial R and D.', *IEEE Transactions on Engineering Management*, vol. 30, no. 2, pp. 83-88.

- CIMdata (2011) *All About PLM*, [Online], Available: <http://www.cimdata.com/plm/definition.html> [May 2011].
- Dahlén, M. (2006) 'From PDM to PLM', Nord PLM '06, Gothenburg.
- DassaultSystem (2011a) *3dvia Composer*, [Online], Available: <http://www.3dvia.com/products/3dvia-composer/> [May 2011].
- DassaultSystemes (2008b) *CATIA 3D Functional Tolerancing & Annotation 2 (FTA)*, Dassault Systemes, Available: <http://www.3ds.com> [24 March 2011].
- ecmaInternational (2007) *Standard ECMA-363 - Universal 3D File*, 4th edition, Geneva.
- Eigner, M., Gerhardt, F., Langlotz, M. and Nem, F.M. (2011) 'Integrated visualisation for supporting decision-making in engineering processes, based on JT', *International Journal Product Lifecycle Management*, vol. 5, no. 1, pp. 37-53.
- Grieves, M. (2006) *Product Lifecycle Management-Driving the next generation of Lean Thinking*, New York: McGraw-Hill.
- Hertzum, M. and Pejtersen, A.M. (2000) 'The information-seeking practices of engineers: searching for documents as well as for people', *Information Processing and Management*, vol. 36, no. 5, pp. 761-778.
- Isaksson, O., Fuxin, F., Jeppsson, P., Johansson, H., Johansson, P., Katchaounov, T., Lindeblad, M., Ma, H., Malmqvist, J., Mesihovic, S., Sutinen, K., Svensson, D. and Torlind, P. (2000) 'Trends in Product Modelling – an ENDREA perspective', *Proceedings of Produktmodeller*, pp. 1-16.
- Johannesson, H. (2010) *Systematic Design - Overview*, Gothenburg: Chalmers University of Technology - Product Development Project course material.
- King, D.W., Casto, J. and Jones, H. (1994) *Communication by engineers: A literature review of engineerings' information needs, seeking process, and use.*, Washington DC: Council on Library Resources.
- Klass, R. (2006) *Introduction to Digital Visualization*, Stuttgart: Daimler Chrysler AG.
- Klass, R. (2008) 'Digital Engineering Visualization Services', ProSTEP Symposium, Berlin.
- Kuffner, T.A. and Ullman, D.G. (1991) 'The information requests of mechanical design engineers', *Elsevier*, vol. 12, no. 1, pp. 42-50.
- Lindkvist, L. (2009) *Geometry Modeling 2*, Gothenburg: Chalmers University of Technology, Advanced Computer Aided Design course material.
- Lowe, A., McMahon, C. and Culley, S. (2004) 'Characterising the requirements of engineering information systems', *International Journal of Information Management*, vol. 24, no. 5, pp. 401-422.

- Malmqvist, J. (2010a) *Engineering Change Management*, Gothenburg: Chalmers University of Technology - Product Lifecycle Management course material.
- Malmqvist, J. (2010b) *Information modelling*, Gothenburg: Chalmers University of Technology - Product Lifecycle Management course material.
- Malmqvist, J. (2010c) *Introduction to PLM*, Gothenburg: Chalmers University of Technology - Product Lifecycle Management course material.
- Malmqvist, J. (2010d) *PLM development process or Software engineering processes for mechanical engineers*, Gothenburg: Chalmers University of Technology - Product lifecycle management course material.
- Malmqvist, J. (2010e) *Product Lifecycle Management (PLM) – overview – focusing on PDM*, Gothenburg: Chalmers University of Technology - Product Lifecycle Management course material.
- McMahon, C., Giess, M. and Culley, S. (2005) 'Information management for through life product support: the curation of digital engineering data', *International Journal of Information Management*, vol. 1, no. 1, pp. 26-42.
- Mohrmann, J. (2000) *ISO 10303-214 Product data representation and exchange: Application protocol: Core data for automotive mechanical design processes*, Ullrich Pfeifer edition, Geneva: ISO - International Organization for Standardization.
- NIST, N.I.i.S.a.T. (2002) *The Initial Graphics Exchange Specification (IGES)*, May, [Online], Available: <http://ts.nist.gov/standards/iges/> [May 2011].
- PDES (1998) *Recommended Practices for AP 203*, PDES, Inc.
- Pinto, J.K. (2010) *Project management-Achieving Competitive Advantage*, 2nd edition, New Jersey: Pearson.
- ProSTEP (2011) *ProSTEP - PDF Generator 3D*, [Online], Available: <http://www.pdfgenerator3d.com/en.html> [April 2011].
- Robson, C. (2002) *Real World Research - A Resource for Social Scientists and Practitioner Researchers*, 2nd edition, Oxford: Blackwell Publishing.
- Roytech (2010) *British Standards - ISO Drawing Aids*, 8 July, [Online], Available: http://www.roytech.co.uk/Useful_Tables/Drawing/Drawing.html [26 January 2011].
- Saaksvouri, A. and Immonen, A. (2005) *Product Lifecycle Management*, 2nd edition, Berlin: Springer.
- SC4ONLINE (2011) *STEP Overview*, 9 May, [Online], Available: [http://www.tc184-sc4.org/SC4_Open/SC4%20Legacy%20Products%20\(2001-08\)/STEP_\(10303\)/](http://www.tc184-sc4.org/SC4_Open/SC4%20Legacy%20Products%20(2001-08)/STEP_(10303)/) [9 May 2011].

- Siemens (2011) *PLM Components*, [Online], Available:
http://www.plm.automation.siemens.com/en_us/ [May 2011].
- Sommerville, I. (2007) *Software Engineering*, 8th edition, Essex: Pearson Education.
- STEP-Tool (2011) *STEP - iso 10303*, [Online], Available:
<http://www.steptools.com/library/standard/> [May 2011].
- Technia* (2010), 10 October, [Online], Available:
<http://en.wikipedia.org/w/index.php?title=Technia&oldid=388802464> [18 May 2011].
- Ulrich, K.T. and Eppinger, S.D. (2008) *Product Design and Development*, 4th edition, New York: McGraw-Hill.
- Waltzer, M. and Dahlén, M. (2010) *Autoliv Inc. Standard, CAD Drawing and Model Standard- AS 109*, Autoliv - internal document, unpublished.
- Weber, W. (2009) *PLM Infrastructure Overview*, Autoliv - internal document, unpublished.
- Wheelwright, S.C. and Clark, K.B. (1992) *Revolutionizing Product Development - Quantum Leaps in Speed, Efficiency, and Quality*, New York: The Free Press.
- Wikipedia (2010a) *ENOVIA MatrixOne*, 1 November, [Online], Available:
http://en.wikipedia.org/w/index.php?title=ENOVIA_MatrixOne&oldid=394158665 [11 February 2011].
- Wikipedia (2010b) *Technia*, 5 October, [Online], Available:
<http://en.wikipedia.org/w/index.php?title=Technia&oldid=388802464> [18 May 2011].
- Wikipedia (2011a) *Benchmarking*, 30 May, [Online], Available:
<http://en.wikipedia.org/w/index.php?title=Benchmarking&oldid=432632839> [2 June 2011].
- Wikipedia (2011b) *ISO 10303*, 23 March, [Online], Available:
http://en.wikipedia.org/w/index.php?title=ISO_10303&oldid=420373138 [May 2011].
- Wikipedia (2011c) *JT (Visualization format)*, 31 March, [Online], Available:
[http://en.wikipedia.org/w/index.php?title=JT_\(visualization_format\)&oldid=431648336](http://en.wikipedia.org/w/index.php?title=JT_(visualization_format)&oldid=431648336) [10 May 2011].
- Wikipedia (2011d) *Universal 3D*, March, [Online], Available:
http://en.wikipedia.org/w/index.php?title=Universal_3D&oldid=430515192 [April 2011].

Appendix A: Interview transcription

Appendix A.1: Interview conclusion from information owners

Interviewees Questions	1 st Engineer (Seatbelt)	2 nd Engineer (A/B)
1. About the note on the note template	n/a	n/a
1.1 The current note template	The template was collected by the CAD coordinator. An engineer who uses some information tells the CAD coordinator to put it there.	Originally, the note comes from CATIA V4 collecting from engineer's needs and requirements by the CAD coordinator made under a long period of time. It is not a standard document.
1.2 The purpose of the note	Supporting document	This list is a supporting document of Engineering work and it is not standard.
1.3 What criteria make the note of each drawing different?	Material and how it is produced. Ex: Metal could be either regular stamping or fine blanking.	Material and technology.
2 .The classification table	n/a	n/a
2.1 Is there any information not use by engineer?	We use only twenty notes from this list, but the rest may be used by others. Also, the note is dependent on how each engineer will call it. Some things are there but never get used or might be used by one	There are some things that we really use, but not all. All notes depend on particular engineers. He also commented that almost everything is outside the note. Only ten notes in here are used. Some

	individual engineer since not all engineer go to the note. The note is just a template.	things do not exist anymore.
2.2 Who is the owner of the information?	An engineer is the one who owns and creates all the data/information. However, there is a review process to check whether anything is missing. Also, it is a two-way communication between the engineer and supplier if something needs to be changed. In addition, the testing requirement is defined by a two-way communication between engineers and suppliers which is always tested by the supplier according to customer requirements.	Engineers are the owners of them. Most requirements are based on customer requirements. Sometimes suppliers cannot complete something, and they require us to change the note (two-way communications).
2.3 Who is the information user of the drawing?	Mainly, it is done for suppliers who produce parts.	Suppliers actually need the drawing to produce parts and industrial designers need the drawing to approve a machine for production.
2.4 Is there any information that does not follow the change control?	No. Nothing in the drawing can be changed without going to the change management process after the drawing is released.	No.
3. Purpose of 2D drawing	As a checklist for supplier that if they have fulfilled all important tasks. Some things cannot be specified anywhere else except in the drawings, such as dimensions, surface references, stamping direction and so on.	As a checklist since a 3D model is the master. If a 2D drawing is wrong but the 3D is corrected then Autoliv has no problem. However, the problem is that it is impossible to put any notes in 3D today since people don't know how to do it.
4. Other communication along with 2D	When drawings are sent to the supplier, some other	Yes, all important documents are located in PLM

drawing?	documents like technical information will be sent to the supplier as well.	and will be sent to people according to the process defined in AS 100.
5. Note		
5.1 SC and CC	From DFMEA and PFMEA, which differ in certain drawings.	From DFMEA and PFMEA, which differ in certain drawings.

Appendix A.2: Interview conclusion from information users

Interviewees Questions	Manufacturing		Supplied Quality (SQ) ¹	Purchasing
	Process Engineer	Manufacturing Quality (MQ) ²	n/a	n/a
1. What kind of product drawing do you use?	Component drawings and Assembly drawings	Component drawings and Assembly drawings	Mainly component drawings and also the small assembly drawings used by suppliers.	Component drawings and Assembly drawings
2. What is the purpose of using product drawings?	-	If the operators find anything wrong, then SQ needs to find out what goes wrong.	-	They use both drawings depending on the production (whether it is a part production or some small assembly task).
2.1 Component drawings?	For figure checking that it is right or wrong (such as dimension, tolerance, and so on) if any problem occurs.	-	To use it as a checklist for measuring dimensions and checking the quality fulfillments that are stated on a drawing note of a part produced by suppliers.	-
2.2 Assembly	To check the correctness of	-	- If the drawing (small	-

¹ This column contains the information from two separate interviews from SQ.

² This column contains the information from two separate interviews with three MQ interviewees participated in total.

drawings?	the part assembling if any problem occurs.		assembly drawing) goes to the supplier, they will check it similar to how they check in the component drawing. - If a drawing does not go to a supplier, normally they will not be interested in it. However, they will look for it sometimes when they want some information relating to the component drawing.	
3. What product information do you use on the drawing?	See Section 4.2	See Section 4.2	See Section 4.2	See Section 4.2
4. Is there any product information that is stated here and does not belong to the group here?	All should be in the group	The group is clearly defined and should cover everything. They think that everything should be in the group.	First interviewee: The product information on the textile drawing and the side-airbag drawing is missing. Second interviewee: No comments on that, but he said some information is not used anymore and a few of them in the table should be moved to other groups.	No comments since they do not actually understand the information through their role but perhaps through their experiences.
5. What is the role of the user's function?	The role of manufacturing is to assemble parts that have been produced by suppliers.	The main tasks of MQ are 1. To check a part/product stated on a drawing when a part/small assembly is produced by any suppliers at the first time. 2. When there is something wrong on the production line,	- They help Purchasing to get verification on a part/small assembly. They are also the last one to see and check a drawing before it is released to a supplier for production.	The role of the Purchasing is similar to a middle man. They will select suppliers either to buy or produce a part and open the communication door between Autoliv (SQ and design engineer) and

		<p>MQ needs to find out what goes wrong with the part/product.</p> <p>3. To make testing on the requested part and report to technical department manually via email.</p> <p>Note that: the verification of 1 and 2 is mainly to measure all dimensions on the drawing and also check the part/product according to the notes related to form, appearance, fitting and technical information excluding a function of the product on the drawing such as weight, strength, surface, gross, colour, check in fixture, and part fitting, to ensure that part/product is lined in the tolerance or acceptable level.</p>	<p>- The role of SQ is to check the fulfillment, correctness and quality according to the drawing and agreement of a part/small assembly that has been produced by suppliers by reading the measuring report and the capability study document from a supplier and comparing it to the drawing. They work together with suppliers to check the suppliers' productions.</p>	<p>suppliers. Also they act as a secretary in the meeting between Autoliv (SQ and design engineer) and suppliers.</p>
6. Are there any documents that the information users use along with the drawing to receive the information?	Yes. Some technical information in PLM	Yes, take a look at information according to the PLM check.	Check the reference documents on the note.	No. Only in the drawing.
7. 3D model	n/a	n/a	n/a	n/a
7.1 How do the information users	They do not actually use the 3D model since there is no	They use the 3D model only to check the direction of the	Normally not. Only when something is not okay, such	Not at all.

<p>actually use the information from the 3D model?</p>	<p>software to support. However, they will ask a technician to convert the CATIA 3D model into a STEP file and use it as an object in process simulation. However, this model format cannot represent GD&T information.</p>	<p>measurement according to all coordinated points stated on the drawing. However, that is the only information that they can extract from 3D model. It would be good to see clear and completed information.</p>	<p>as some dimension lines outside tolerance! The 3D model is for suppliers to order or set up a tool for production.</p>	
<p>7.2 What system for 3D models do the information users work on?</p>	<p>They use the Autodesk system to design the assembling process.</p>	<p>Only Mi-CAT, which is a measuring program. Mi-CAT can read CATIA files but only the coordinate points and measuring directions (generally perpendicular to the surface) are shown there. It is not possible to view and get any other information.</p>	<p>No.</p>	<p>Not at all.</p>
<p>8. Opinion about removing the 2D drawing.</p>	<p>No comments since they do not actually know the information through their role, but perhaps through their experiences.</p>	<p>Not that ok since they don't have any 3D CAD system and 2D is important for them and some working stations are not able to access to a computer. 2D is accessible and convenient to read and check.</p>	<p>Not ok at all. Since a 2D drawing is the only document that contains all the critical information of the part/product that needs to be checked in one document. Also, they cannot access to CATIA and at the production plant, not every operator can use or have a computer everywhere. The drawing is accessible and easier to take a look at by everyone.</p>	<p>Unacceptable, since the drawing is the only information they have. However, if there are any other replacements, it is acceptable.</p>

Appendix A.3: CAD-PLM case study from volvo car corporation - Interview transcription

CAD-PDM system at VCC

- PDM system at VCC: Teamcenter Engineering (TCE) from Siemens (Origin from Ford).
 - PLM system at VCC: KDP (Developed by VCC as Script).
 - CAD system at VCC: Multi-CAD system, including CATIA V4, V5, and IDS but mainly here is CATIA V5 R18 sp4 from Dassault system (Have plans to go for CATIA V5 R21 or V6).
 - Operating system at VCC: Window xp 32 bit, Vista 64 bit, and Unix.
1. A 3D model instead of a 2D drawing: An engineer does not create 2D drawings anymore. Only 3D PMI (Product Manufacturing Information) is used, which is a 3D model with all the information on the 2D drawing.
 2. Tech/solution for moving to 3D
 - Tools for putting 3D information on a model >> Using FTA module: two separated modules which are 'FTA' for putting tolerances and 'Product FTA' for putting dimensions on the model. They are in separate modules since they both need to be viewed separately.
 - PLM: Teamcenter Engineering.
 - TCE is used, from Ford.
 3. File format used
 - JT, for two main reasons:
 - o 1. It is a native format for Teamcenter, Siemens.
 - o 2. It is a light format for Teamcenter.
 - o 3. There is a great deal of potential; for example, it is an accurate format (such as for making tools), all the geometrical information from a whole car can be recorded and carried through this format, and it can carry all needed and suitable information via this format, among other things.
 4. Any document replacement?
 - There is no document replacement. They introduce a new type of file which is a 3D PMI and a viewing module added on Teamcenter is used.

- There is no 2D drawing in this new solution. They use 3D PMI to store every bit of information instead (it contains the 3D model and information from the 2D drawing, such as dimensions, tolerances, and notes). Notes on 3D PMI are placed at a zero coordinate reference to a whole car related to the part and a template which applies only for one kind of part. Currently, there is only one template for a sheet metal part. If any other new part implements the existing solution, a new template for the part will be generated.
 - This viewing module is called Teamcenter Visualization (TCVis), which is built in Teamcenter. It can read JT format and all the information in 3D PMI as the JT file can be viewed here. The reader in VCC does not need to have any CAD system since they can view the file through TCE by using TCVis.
5. How can VCC communicate to suppliers?
 - Suppliers can use JT2go, which is a freeware, to view the 3D PMI file since it is a JT format.
 - Also as long as a file is a JT format from suppliers, VCC can view it by using TCVis.
 6. To what degree is this sheet metal a part of the assembly, since only the sheet metal is in 3D but other related parts are still in the 2D drawing and 3D model and it looks much different than a single part?
 - Even a component part of sheet metal is in a form of 3D PMI. Assembly drawings of this sheet metal part with other related parts will be created in the form of a 2D drawing.
 7. Do you have both component drawings and assembly drawings?
 - The component drawing of the sheet metal part will be created in the form of 3D PMI.
 - The assembly drawing of the sheet metal part will be created in form of a 2D drawing since other related parts do not have 3D PMI.
 8. Was there any problem? How could we make people get used to that?
 - Yes, there were some problems. For example, some parts from CATIA V4 are not able to create a solid model (only 1%), not all downstream people have a computer to view this, people against the new system from the start (especially older people who have worked for a long time since they think 2D drawing is everything), and so on.
 - They made people get used to the changes by training and introducing new methods. There is a function to create a 2D drawing from 3D PMI for shop-floor people and other people who want to use a 2D drawing but they need to create it themselves. Engineers will not create 2D drawings anymore.
 9. Why does VCC not implement the existing solution to the other parts as well since now only sheet metal can utilize the solution?
 - They have plans to implement the solution to other parts. However, right now, they only implement it on sheet metal first since it is the easiest part to do. A plastic part is the next step with which they will use this solution.

Appendix A.4: Analysis of feedbacks from interviewees regarding the suggested system with users' functions

Functions of Users / Feedback Classifications	Engineering ³	Manufacturing	MQ ⁴	SQ	Purchasing
General comment	- It is an interesting system.	- Overall system seems to be good because all the information is still maintained. - Better comments could be given after one has tried and seen the system.	- It is a nice solution, and it seems as though the solution really supports their work and makes it better. - The whole system is easier to use.	-	- For a better judgment, one needs to be more familiar with the suggested system since it is simpler to comment after one has been working with the system for a while.
In Product information page	- It is good that all notes are managed in the PLM system. - Link to reference document near the notes is great since there is no need to search for it. - Note browsing function is benefit	-	- It is good to classify the note which is easy to see and find associated documents.	- Providing quick links to associated documents to notes is great. - Browsing function is good.	- Providing quick links to associated documents to notes is good.
Report generator	- It is better to pick what you want (Possible to	- The customization of generated reports and product information is	- It is good for customization to select what they want.	- Document generator customization is a good function.	-

³ This column contains the information from two separate interviews from Engineers.

⁴ This column contains the information from two MQ interviewees.

	customize).	great.			
Usability of 3D PMI - JT	<ul style="list-style-type: none"> - 3D PMI model shows clearer geometrical product information since a lot of views on drawing need to be created just for expressing some information for suppliers. - The 3D PMI model will reduce the amount of explanations required in 2D drawings. 	<ul style="list-style-type: none"> - It is great for flexibility to choose a projection view of a 3D model before printing for shop-floor people. 	<ul style="list-style-type: none"> - The possibility to select any view of a model to be viewed in 3D PMI is good. 	-	-
Usability of JT, neutral format of 3D model	-	<ul style="list-style-type: none"> - The availability of a potential neutral 3D CAD format that can preserve all necessary geometrical information of its native 3D CAD file in the PLM system is valuable. It saves file conversion time and supports process simulations in manufacturing. 	<ul style="list-style-type: none"> - It is good that completed information on neutral 3D CAD format (especially GD&T) can be viewed when using Mi-CAT, the measuring program to open 3D data. 		
2D drawing removal	<ul style="list-style-type: none"> - 2D drawing removal seems to be impossible since everything is there. Hence, if this 	-	-	-	<ul style="list-style-type: none"> - A current drawing is easier for them since currently drawing is a single package of

	system is implemented, 2D drawings should still be preserved.				documents. The suggested system is seen to be a good deal more work to click and it could lead to a risk of missing some necessary information.
--	---	--	--	--	---

Appendix A.5: Analysis of suggestions from interviews regarding the suggested system with users' functions

Functions of Users / Suggestion Classifications	Engineering	Manufacturing	MQ	SQ	Purchasing
General function	- In an assembly model, it should be able to display only dimensions and tolerances related to assembly and hide all individual dimensions of a part to avoid confusion. - When will this system be able to used?)	-	- Function or possibility to share testing results of a part through PLM.	- In PLM system interface, favorite setting of user interface for each user.	-
Product information page	- A note template for each type of a part to standardize notes and to reduce ambiguity and increase the possibility to write extra notes.	-	-	On the product information page, <ul style="list-style-type: none"> Three categories of notes should be located on different pages under the product information 	-

	<p>- In the product information page, there should be a template for each part type and the reference number in front of a note should be updated automatically.</p>			<p>group.</p> <ul style="list-style-type: none"> • There should be options for selecting the number of notes per a page, so people don't need to scroll down too much. • Function to create shortcuts for some specific group of notes should be provided, allowing PLM user interface customization. • Associated documents to notes attachment should be set as a mandatory activity that an information creator must do before proceeding to the next step. 	
<p>Report generator</p>	<p>- In the four new report generator options in the report page, different pre-defined selections of necessary note groups or documents specific for a user's function</p>	<p>-</p>	<p>- It will be convenient to be able to include a testing result of a part into a customized drawing, a single document package and to share it in the PLM system, since</p>	<p>-</p>	<p>On the report page, document content selection should be differentiated for internal and external users.</p> <ul style="list-style-type: none"> • For internal users, the complete level

	should be provided to avoid information missing and miscommunication.		nowadays a testing result is manually sent to the technical department that requests the document.		<p>of selections without any limitation should be available for all internal users.</p> <ul style="list-style-type: none"> • For external users, there should be some pre-defined mandatory content selections included in the report generator option pages since there is a risk for suppliers that they could miss something.
Training	-	-	-	- A workshop for Autoliv's suppliers teaching how to use new features of the suggested system must be arranged to provide a clear understanding for external users.	- Training is required for both internal users and suppliers.
Neutral 3D CAD data exchange format	-	- Ensure that the chosen neutral 3D CAD model can provide complete product information in other CAx systems	- In using a neutral 3D CAD model, it would be good to also consider 'workshop,' a section of making a particular tool to support the		-

		since currently the STEP file cannot carry GD&T information	production line and testing upon request, so as to allow them to use this 3D model with complete information to design and build precise and accurate tools.		
Risk	<ul style="list-style-type: none"> - With this 3D master concept, there is a security risk that suppliers could steal confidential information from the PLM system. Thus, Autoliv needs to make sure that the current PLM system can guarantee data security. - Customization risk: A risk that the supplier may not select all the necessary notes/documents, resulting in information missing and miscommunication. SQ could pre-select the important item for suppliers. 	-		-	-
Implementation	- Time required to	-	- Connect DVM	- System should be	- The 3D master

<p>related</p>	<p>make the suggested system work in practice needs to be considered by comparing it with the time frame of new advanced CAD and PLM system technology and defining the return on investment.</p> <ul style="list-style-type: none"> - New Autoliv standard documents, related to contexts of how to create 3D drawing or 3D PMI model, must be formulated. - When will this system be able to use? (One wants to use it.) 		<p>system, which is an additional parallel system to PLM system storing all information related to testing, to PLM system. To have PLM single access for all information.</p> <ul style="list-style-type: none"> - When it will be implemented in practice? They are looking forward to use it. 	<p>stable before use in production.</p> <ul style="list-style-type: none"> - Before system implementation, the system users must see and use PLM as a main centre. - Provide a suggestion forum for internal and external users to give feedback for directly improving and debugging the system. 	<p>concept should be started to implement with Die casting suppliers than begun with some uncomplicated part-suppliers. Simple part-suppliers do not have as much experience working on 3D models as Die casting suppliers do.</p>
-----------------------	--	--	--	---	--

Appendix A.6: Interview transcriptions of suggestions to reduce change resistance

From Engineer 1

- Point out benefits for all related functions (including Engineering, Manufacturing, MQ, and SQ) to reduce change resistance and to make it easy for suggested system changes.

From SQ

- Impress people by debugging the suggested system before introducing it in practice.
- Set a test group of people who have negative feedback regarding the suggested system and provide some presentations to make them get used to the system and increase the acceptance level.

From Manufacturing

- Make people get used to the system.

From Purchasing

- Make people get used to the system.

From Engineer 2

- Set the trial system or live test system in PLM for the users to show how it would work to more easily explain the reasons for the changes.
- Provide information for the suggested system users to avoid conflicts.

From MQ

- It is hard to avoid change resistance.

Appendix B: Classification table

Appendix B.1: Classification of reference documents in the classification table

1. Reference to internal documents

1.1.Reference to global Autoliv (AL) standard such as:

- AS documents: Autoliv Standard
- ATS documents: Autoliv Technical Specification

1.2.Reference to local AL standard such as:

- ALTM: Autoliv Test Method defines a test method from testing activities performed in repeatable manner (ATS documents that replace ALTM.)
- ALS-SP: Autoliv Sweden Standard Procedure
- MPS: Manufacturing process specification such as MPS 017

1.3.Reference to local document: It is a newly created report every time the project starts in order to perform as a reference document for some specific purposes such as:

- Reference number of each dimension
- E document: It is a reference document that is created along with the specific project for technical description and clarification purpose, such as E455829.
- ALTR: Autoliv Technical Requirement

2. Reference to external documents

2.1.Reference to international standard such as:

- ISO
- DIN
- ASME

2.2.Other external standard: It is a reference to customer standard and a reference to supplier standard

- VCC TR XXXXXXXX: Standard requirements from Volvo Car Corporation
- GMW: Standard requirements from General Motor

Appendix B.2: Classification table

Ref. to External Doc.		Ref. to Autoliv Internal Doc.			Generic Groups of Information	Product information found on 2D drawing	Description
International std.	Other ext. std./req.	Global AL std.	Local AL std.	Other ref. local doc.			
					1. Engineering Specification		
					1.1 Pictorial and Orthographic description		
					1.1.1 General Pictorial and Orthographic description		
					<i>a) Multiple view and projection on a drawing</i>		
					Multiple view and projection on a drawing	Multiple view and projection on a drawing	Graphical description
					<i>b) Cross sectional view</i>		
					Cross sectional view	Reference cross sectional surface/view	n/a
					<i>c) Exploded view</i>		
					Exploded view	Exploded view	n/a
					<i>d) Reference view</i>		
					Reference view	Surface reference related to dimension and tolerance	Tolerance and dimension referred to specific surface
					Reference view	The shaded area is a 'Mating surface' The unshaded area is a 'Other surface'	n/a
					Reference view	Referenced point on surface related to xyz coordinates of 3D model.	n/a
					Geometrical tolerance and Reference view	Profile tolerance see Cover surface identify points list.	n/a
					1.1.2 Other Pictorial and Orthographic description		
					<i>a) Part/Product descriptions</i>		
					Part or sub-part orientations	Omega spring to be oriented as shown	n/a
					Part or sub-part orientations	Description of some part orientation with drawing, orientation and textual descriptions such as gasgenerator orientation	n/a
					<i>b) Text labeling on a part</i>		
				x	Text labelling on a part	Traceability label printing instruction accd. to GM std. 1737	n/a
					Text labelling on a part	Sample view of label printing	n/a
					Text labelling on a part	Detail description of each line in a label printing	n/a
					Text labelling on a part	Text labeling on some specific part such as Cust. Part no., ALS part no., Angle, and Date.	n/a
					<i>c) Feature illustration</i>		
					Feature illustration	Position of holes	n/a
					Quality requirements&Feature illustration	Free from everything except from what is specified on drawing	n/a : Probably drawing is changed to notes
					1.2 Dimension and Tolerances		
					1.2.1 Dimension Philosophy		
					Dimension philosophy	Dimension	n/a
					Dimension philosophy&Marking and printing	Draft angle where nothing else is stated ___ MAX	n/a
					Dimension philosophy	Material thickness not specified	Unspecified material thickness
					Dimension philosophy	Inside/inside bending/bending/corner radius	Dimension as particular radius
					Dimension philosophy&Production process info.	Dimensions and weight including tie bar and surface treatment	Total weight
					Dimension philosophy	[SC] Flange and bending radii w/o cracking	n/a
				x	Dimension philosophy	Reference no. of each dimension for communication	n/a
					1.2.2 Geometrical tolerance		
					Geometrical tolerance	Geometrical Tolerance	n/a

					d) Surface and texture		
					Product descriptions	Surface roughness: Ra _____ micrometer	n/a
					Product descriptions	[SC] Gloss _____ Gardner	Glossy
				x	Product descriptions	[SC] Colour accd. to master sample _____	n/a
				x	Product descriptions	[SC] Painting accd. to _____	n/a
				x	Product descriptions	[SC] Surface structure accd. to master sample	n/a
				x	Product descriptions	[SC] Pattern accd. to master sample	n/a
			x		Product descriptions	[SC] Surface classes accd. to ALTR 570 6385 00	ALTR is Autoliv Technical Requirements
					e) Quality requirements		
					Quality requirements	[SC] Polished surface	n/a
					Quality requirements	Burrs _____ MAX	Burr is an unwanted piece of material after SQ
					Quality requirements	[SC] Free from burrs	n/a
					Quality requirements	Flash height _____ MAX	Flash is an excess material attached to a part must be removed.
					Quality requirements	[SC] No visible sink marks on surface	Aesthetic reason
					Quality requirements	[CC] Free from hydrogen and embrittlement	n/a
					Quality requirements	Free from embrittlement	n/a
					Quality requirements	Free from grease, dirt and foreign particles	n/a
					Quality requirements&Feature illustration	Free from everything except from what is specified on drawing	n/a
					Quality requirements	Free from casting blow holes, cavities and cracks	n/a
					Quality requirements	[SC] Free from cracks	n/a
					Quality requirements	[SC] Free from cracking	n/a
					Quality requirements	[SC] Free from silver splash	n/a
					Geometrical tolerance and Reference view	Profile tolerance see Cover surface identify points list.	n/a
x					Geometrical tolerance	Tolerance definition accd. to ISO 1101	n/a
					1.2.3 Tolerance stack		
					Tolerance stack	Tolerances unless otherwise stated	n/a
					Tolerance stack	General tolerances as a table	n/a
					Tolerance stack	Dimensioning tolerance	n/a
					1.3 Part/Product requirements		
					1.3.1 Part/Product definitions		
					a) Form and feature		
					Product descriptions	Edge deviation at meeting cut ± _____ allowed	n/a
					Product descriptions	Trim edges	n/a
					Product descriptions	Sharp edge broken _____ MIN	n/a
					Product descriptions	Cut out is allowed	n/a
x					Product descriptions	Workpiece edges accd. to ISO 13751	n/a
					b) Product type		
					Product descriptions	Product type such as Inflator , A/B, Seatbelt and so on.	n/a
				x	Product descriptions	Propellant type accd. to MSDS1	MSDS is the Material Safety Data Sheet.
	x			x	Product descriptions	Connector on airbag module accd. to _____	n/a
					c) Material		
x					Product descriptions	Material used or referenced industry standard	n/a
				x	Product descriptions	Restrict substance and material std. accd. to GMW 3059	n/a
					Product descriptions	[SC] Uniform glass	n/a
				x	Product description	[CC] Flammability requirement accd to FMVSS 302 . Burning rate<_.	n/a

					Quality requirements	[SC] Free from sink marks	n/a
					Quality requirements	[SC] Allowed surface imperfections of small size and limited height. Max 2 Pcs. of imperfections on a planar surface, not edge w/i diameter of 10 mm where func is not affected.	n/a
					Quality requirements	No imperfection allowed	n/a
					Quality requirements	No foreign particles inside module	n/a
					f) Variants		
					Variants of a part	Variants table which contains some specific variant part of a drawing such as Retractor assy. no., Ret. type, Spindle part no., Torsion bar, Bearing, Tread head, Housing T-N, Steering pin part no., Mech cover inner, Lever T EA, Chaild safety system assy., Mech assy part no., CL. package assy part no., Gasgenerator part no., Spring assy. part no. and so on.	Available variant information of the components
					Variants of a part	Description of part variants for color, material/finish, and inert parts	n/a
					g) BOM	* Note this is prohibited to put on a drawing accd. to AS 109.	
					BOM	Part list/Bill of Material (BOM)	A user wants to see it when they see the drawing.
					h) Tracability level accd. to AS 4		
					Tracability level accd. to AS 4		
					1.3.2 Technical information		
					Technical information	Mass with metric unit	n/a
					Technical information	[CC] Tensile strength: ____ MIN	Product spec
					Technical information	[CC] Torque strength: ____ MIN	Product spec
					Technical information	[CC] Shearing strength: ____ MIN	Product spec
					Technical information	Pyro technical weight: _____	Weight measuring technique
					Technical information	Max authorized pyrotechnical weight:	n/a
					Technical information	Pyrotechnical weight total:	n/a
				x	Technical information	MSDS NO. (Material Safety Data Sheet): E395827	n/a
					Technical information	Surface hardness	Resistance of material against penetration
					1.3.3 Standard part/product identification		
	x				Standard part/product identification	[CC] Screws ____ Class ____ Min	n/a
	x				Standard part/product identification	[CC] Nut ____ Class ____ Min	n/a
	x				Standard part/product identification	List the standard product referenced (ISO 1101)	n/a
					1.3.4 Product certification/approval		
					Product certification/approval	BAM No. Inflator: PTI - 1172	Approval for putting an inflator on the market
					Product certification/approval	DOT No. Inflator: DOT - EX2005070691	Approval for putting an inflator on the market
					Product certification/approval	BAM No. Module: PTI - 1732	Approval for putting an inflator on the market
					1.3.5 External requirement fulfillment		
				x	External requirement fulfillments	[CC] Technical regulation Volvo TR 31810392	n/a
					External requirement fulfillments	[CC] Must meet the following legal requirement/technical regulation/specifications accd. to ____	n/a
					External requirement fulfillments	[CC] Must meet the following points accd. to tech. regulation ____	n/a
					External requirement fulfillments	[CC] Must meet the following legal requirement/technical regulation/specifications accd. to ____	n/a
					External requirement fulfillments	[CC] Must meet the following points accd. to tech. regulation ____	n/a
				x	External requirement fulfillments	Part has to fulfill VDG-SPECIFICATION P201 D	Fulfillment of the requirement
					1.3.6 Making and printing		

				x	Marking and printing for C.	[CC] Product marking with bar codes accd. to _____	n/a
					Marking and printing for S.	Marked with Batch No.	n/a
					Marking and printing for S.	Depth marking	n/a
					Marking and printing for S.	Planish marks allowed on outside surface	Planishing is a metalworking technique to smooth the surface
2. Manufacturing information/technique							
2.1 Production process requirements							
2.1.1 Production technology							
					Production process requirements	[SC] √ refers to "Feintool" master: _____	It is technology fineblanking process company.
					Production process requirements	[CC] Hardened and tempered	n/a
					Production process requirements	Surface treatment SS-ISO 2018 and SS-ISO 4520	n/a
					Production process requirements	Black electrophosfatic paint _____ μm	Anti-corrosive painting
					Production process requirements	[SC] Tumbling required as final surface treatment	It is a technique for smoothing and polishing a rough surface
					Production process requirements	Casting: MAX _____	A SQ process by which a liquid material is usually poured into a mold.
					Production process requirements	Flattening ___ allowed - Flash included in diameter	n/a
2.1.2 Production information							
				x	Production process information	Supplier quality requirement: see supplier manual	n/a
					Dimension philosophy&Production process info.	Dimensions and weight including tie bar and surface treatment	Total weight
					Production process information	Steadily increasing from _____ to _____	SQ description
					Production process information	Control fixture for cushion interface _____	Control the fixture tool not to cash
					Production process information	Ejector burr: MAX _____	n/a
					Production process information	Ejector depth: MAX _____	n/a
		x			Production process information	Tie bar pull-off load min _____ kN accd. to ATS...	n/a
					Production process information	Tie bar riveted to frame to choice of supplier	n/a
2.1.3 Verification after Production							
					Verification after production	Verify dimension at some reference points on the drawing	n/a
					Verification after production	Checkpoint, thickness of surface treatment	n/a
					Verification after production	Table of referenced points on surface related to xyz coordinates of 3D model	n/a
2.2 Assembly process requirements							
2.2.1 Assembly technology/technique							
				x	Assembly technology/technique	[CC] Riveting _____	n/a
					Assembly technology/technique	Disassembly force	n/a
					Assembly technology/technique	Airbag folding accd. to floding instruction E315535 000	n/a
					Assembly technology/technique	[SC] Adhesion accd. to _____	n/a
2.2.2 Assembly information							
			x		Assembly information	[SC] Apply grease per MPS 065 : _____ + _____g. _____g grease minimum per location	MPS is the document stating how to manufacture that part in the best way
					Assembly information	[SC] Torque _____ Nm MIN /screw	n/a
					Assembly information	[SC] Pushout force _____ Nm MIN /screw	n/a
					Assembly information	[SC] Tightening torque _____ + _____ Nm	n/a
					Assembly information	No grease or lubricant for assembling is allowed.	n/a
					Assembly information	Squib: _____	It's a miniature explosive device.
					Assembly information	Resistance in cable harness + squib for stage 1 and 2: _____ at _____'C	n/a
					Assembly information	Resistance for grounding: Max _____ m-ohm at _____'C	n/a

					Assembly information	Clusion fabric may stick out less than 2m out of cover, etc.	n/a
					Assembly information	[SC] Screws must stand tightening torque ___ Nm MIN through clearance hole ø ___ w/o casting deformation	n/a
				x	Assembly information	Deviation approval ___ is valid for tool no. ___	n/a
				x	Assembly information	Minimal strength must be ___ kN in fixture accd. to Autoliv requirement specification E501586 for spindle 616 5017 (Part no.)	n/a
				x	Assembly information	[SC] After assy. : Axial force required to separate tread head assy. From spindle to be ≥ ___ N per Autoliv spec E455829	E455829 is the report that refers to some particular info which states reasons of decreasing severity level from PFMEA .
				x	Assembly information	After assy. Axial force required to separate spindle ring from spindle to be ≥ 150 N per Autoliv specification E472683	E472683 is the report that refers to some particular info which states reasons of decreasing severity level from PFMEA .
2.2.3 Verification after assembly							
					Verification after assembly	Defined points measured at gap above lock dog	Lock dog is a device for holding a log in place while it is being worked (a mechanical clamping device).
					Verification after assembly	All clip in fixation closed	n/a
					Verification after assembly	Checked in fixture ___	A support device used in the manufacturing industry.
				x	Verification after assembly	Dimension marked with * shall be checked in fixture	n/a
				x	Verification after assembly	[SC] Color measuring: Demand ΔE ___. Measured accd. to ___	n/a
					Verification after assembly	Δ Area for measuring of gloss and colour	n/a
2.2.4 Logistics information							
				x	Logistics information	Packing instructions accd. to AL-230-016	n/a
				x	Logistics information	Handling instructions accd. to ALTR 570 6320 00	n/a
2.3 Controlled manufacturing induced affects							
					Controlled manufacturing induced effects	For direct current ignition	n/a
					Controlled manufacturing induced effects	For altering current ignition	n/a
					Controlled manufacturing induced effects	Die seperation marks MAX ___ allowed	n/a
					Controlled manufacturing induced effects	Die seperation line for lateral side	n/a
					Controlled manufacturing induced effects	Area for spindle assembly identification	n/a
					Controlled manufacturing induced effects	Feed gate	Raw material injection location
					Controlled manufacturing induced effects	Ejector marks recessed allowed only	n/a
3.Verification requirements							
					Testing requirements	Opening force to be tested	n/a
					Testing requirements	[SC] Strength split line to be tested.	n/a
				x	Testing requirements	[SC] With break test, parts from the Ni-Cr coating must not flask off accd. to ATS...	n/a
				x	Testing requirements	[SC] With saw test, parts from the Ni-Cr coating must not flask off accd. to ATS...	n/a
				x	Testing requirements	[SC] Free from red rush, white rust or corrosion after test accd to ATS...	n/a
					Testing requirements	[CC] Electrical test accd. to ___	n/a
					Testing requirements	F test/pull/extraction/retraction accd. to VCC TR XXXXXXXX.	n/a
				x	Testing requirements	Breaking load min ___ daN accd. to ATS...	n/a
				x	Testing requirements	Stake safety plate and verify lock dog function per MPS 017	MPS is the document stating how to manufacture that part in the best way.
					Testing requirements	100% check of presence of a part such as a deflector	n/a
					Testing requirements	100% check of plausibility such as check bag and check inflator	n/a

Appendix C: The information model of the current e-part page in the PLM system

Appendix C.1: The first section of the information model of the current e-part page

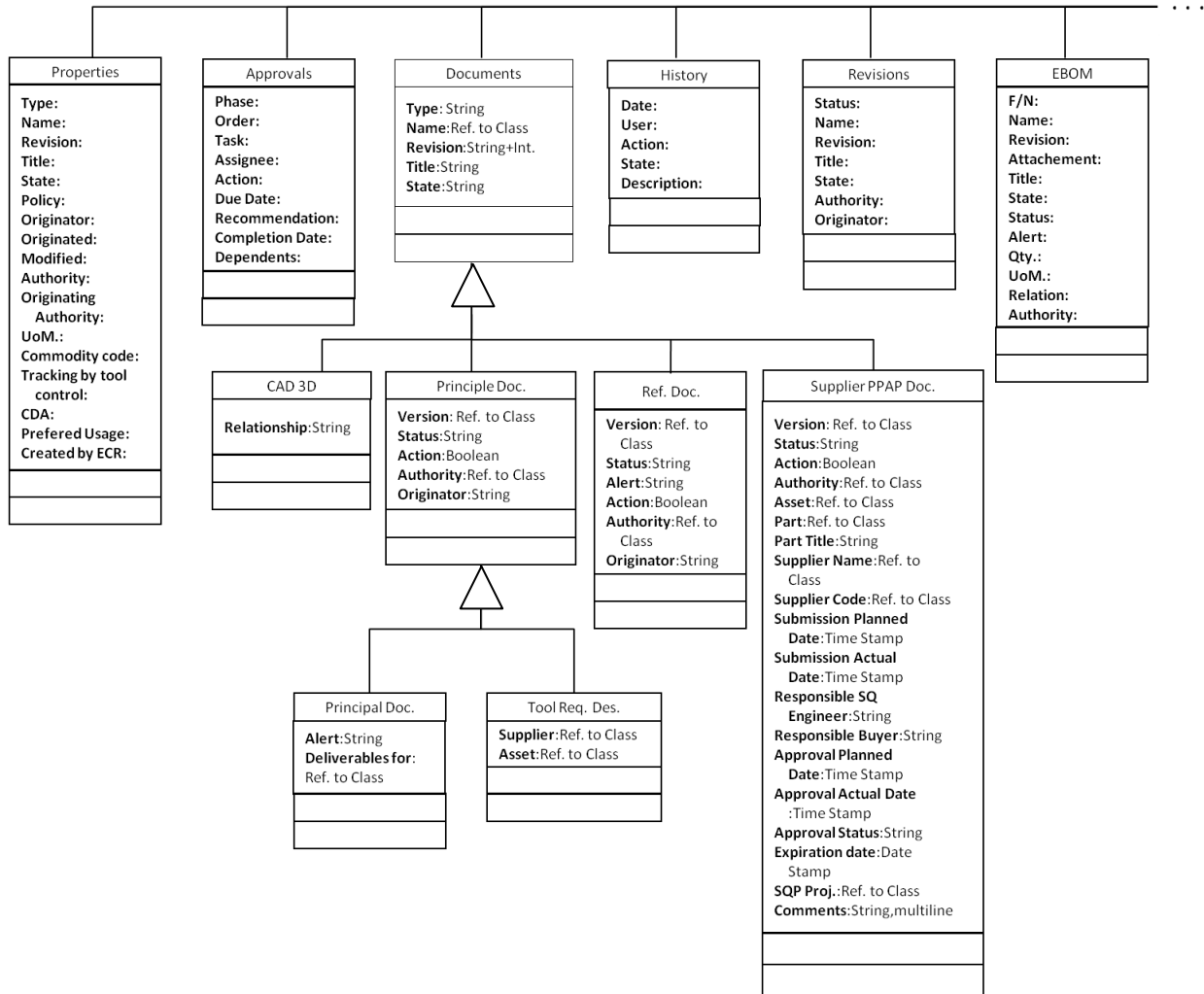

Appendix C.2: The second section of the information model of the current e-part page

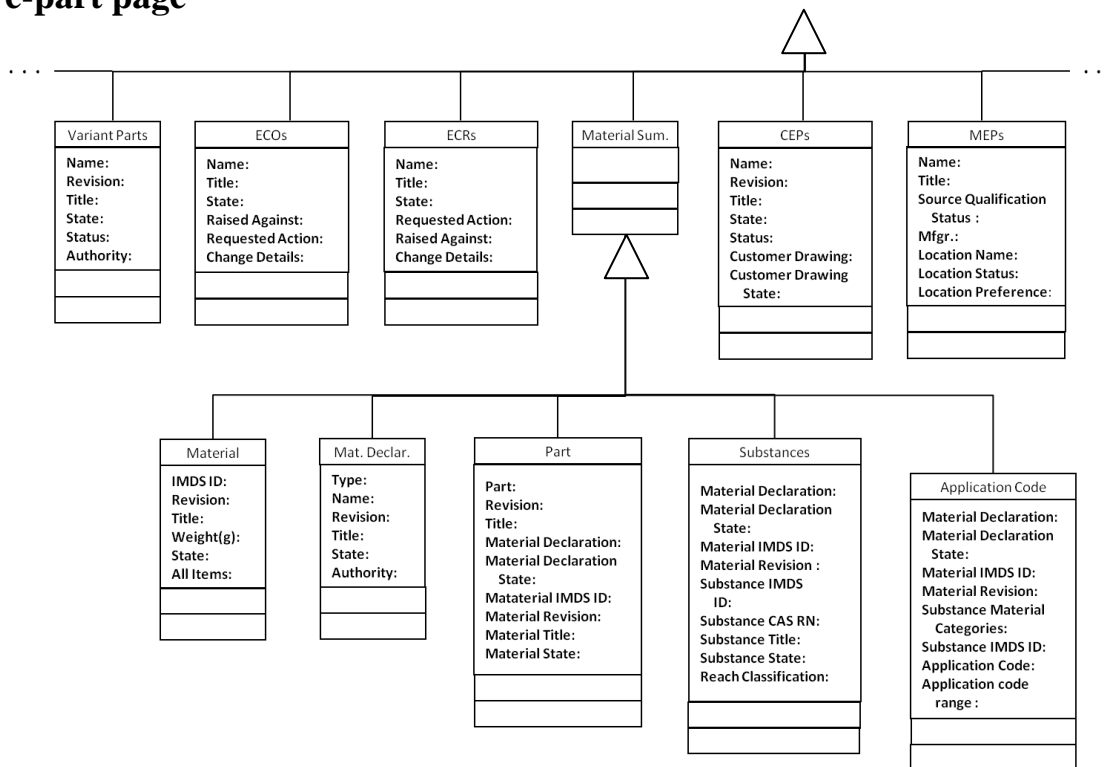

Appendix C.3: The third section of the information model of the current e-part page

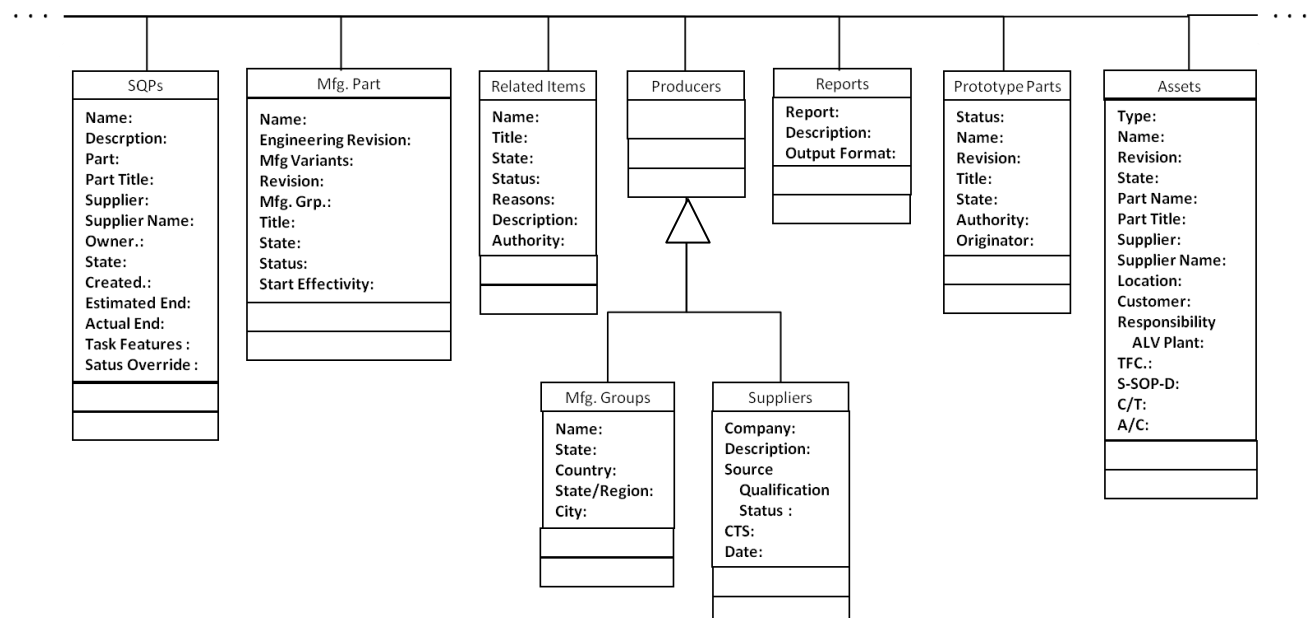

Appendix C.4: The fourth section of the information model of the current e-part page

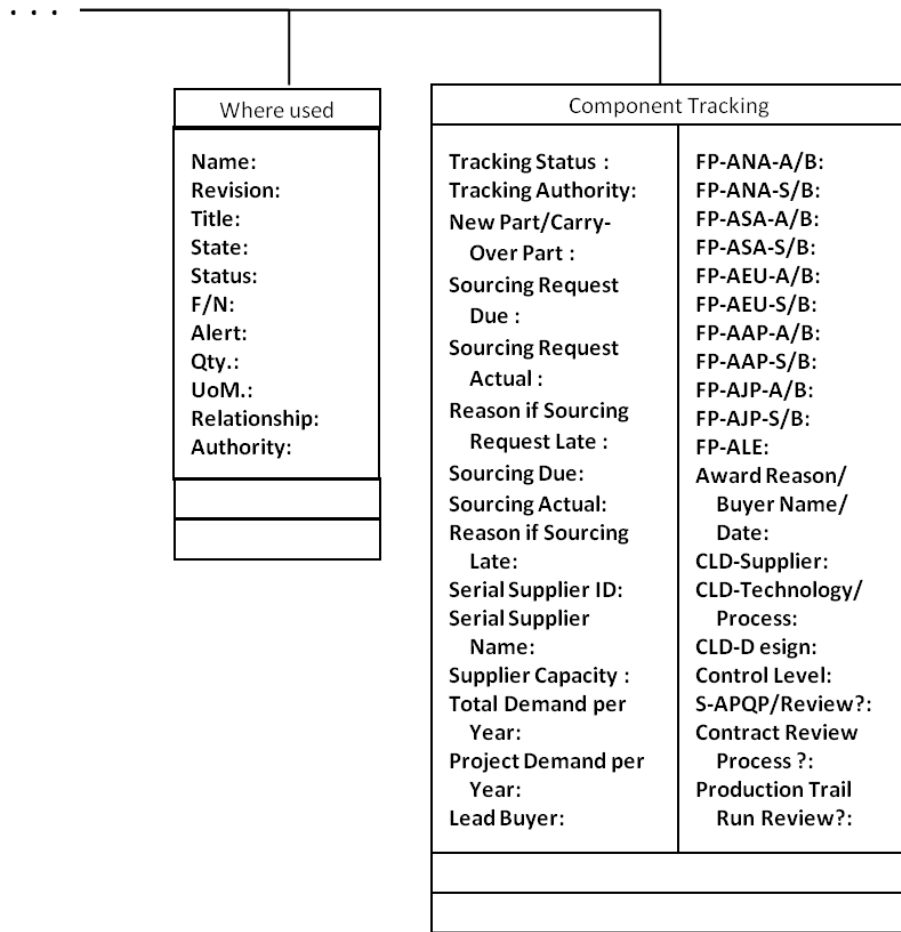

Appendix D: Information related to the suggested system

Appendix D.1: Document generator system candidates

1. PROSTEP PDF Generator 3D for Adobe LiveCycle: The application belongs to ProSTEP with Adobe's Lifecycle technology utilization. It is a system to convert complex 3D CAD data and integrate it to product defining metadata from existing backend systems, and any other existing files into Adobe PDF files which look exactly the same as the original documents and preserve source file information-including text, layout, forms, 2D drawings, 3D designs and PDM metadata. The overview of the system is illustrated in Figure 24. There are four major components in the system (ProSTEP, 2011).

- **Base server component:** This component is the part that creates a secured PDF document package from 3D model and other information in the form of metadata from PLM. Basically, it is a document generator part that contains six sub-components. These include **XML metadata integration** for integrating data from backend systems based on XML into PDF templates and extracting it again, **XMP integration** for integrating standard properties into the PDF documents, **Basic Encryption** for securing PDF documents based on password protection, **Packaging** for assembling various contents into a PDF Package, the **Adobe LiveCycle Workbench** for defining enterprise workflows, and the **Adobe LiveCycle Designer** for creating and modifying PDF templates (Quote ProSTEP (2011)).
- **CAX translators:** Generally, it translates various native CAX system file formats (including the CATIAV5 format) into an intermediate neutral format that the system can understand (U3D or PRC), which will be clarified in later in Appendix D.2. The possible input CAD formats are classified in Table 5 with their vendors, versions, and possible data types of each format that can be converted into the PDF document.
- **PLM connectors:** The connectors connect PLM to the base server component, which is possible to connect to several PLM systems including ENOVIA allowing data exchanging.
- **Additional Adobe lifecycle Components:** The system allows the users to combine additional functions from Adobe for customization and different purposes and requirements of each user such as the right management requirement.
- **Working procedure:** PROSTEP PDF Generator 3D allows the translation, extraction and integration of 3D CAD geometry models into a PDF document package that is able to be viewed dynamically by using the Adobe Reader. The PLM system exports CAX data, metadata, structure, and other documents to the ProSTEP PDF generator 3D to aggregate and generate on PDF template into one intelligent PDF document package. Currently PDF can carry several additional contents. They are barcode integration 3D viewports,

links that activate 3D views, data collection via form fields, XML data integration (ERP/PLM), PDF Portfolio, animation, geometry with PMI, GD&T or FT&A, audio & video integration, attachments, and digital signatures (ProSTEP, 2011).

This intelligent PDF file includes 3D data and other new contents can be viewed, rotated, zoomed, customized, and some other functions by using Adobe Reader® 9 or later software version that can be downloaded without any cost. Figure 25 demonstrates an example of a 3D PMI file in the form of an intelligent PDF document (ProSTEP, 2011).

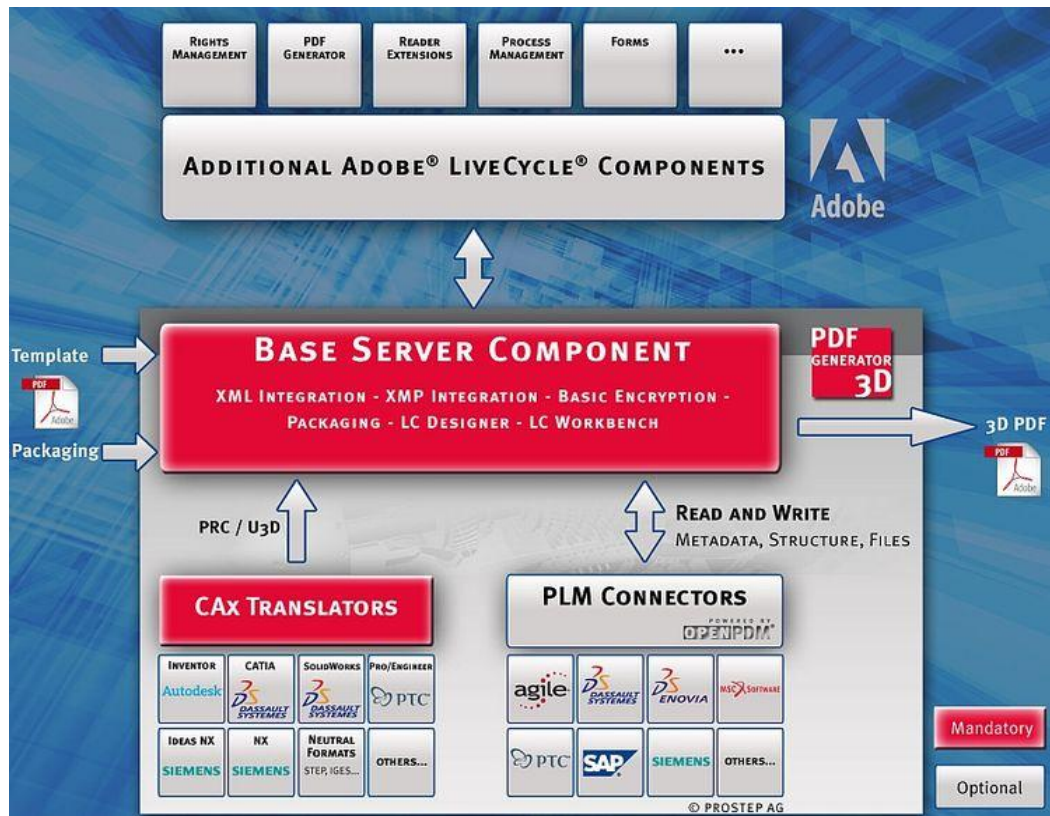

Figure 25: The components of the PDF Generator 3D (ProSTEP, 2011)

Vendor	Format	Version	Tess.	B-Rep	PMI
3D Systems	STL		✓		
ANS US	IGS, IGES	5.3, 5.2, 5.1	✓	✓	
Autodesk	Inventor	Up to 12.x, 2010	✓		
Dassault Systèmes	3D-XML	Up to 3.0	✓	✓	
Dassault Systèmes	CATIA V4	Up to V4.2.5	✓	✓	
Dassault Systèmes	CATIA V5	Up to R20	✓	✓	✓
Dassault Systèmes	CGR	Up to 3.0	✓		
Dassault Systèmes	SolidWorks	Up to 2009	✓	✓	
ECMA 363	Universal 3D	ECMA 1, ECMA 3	✓		
ISO 10303	STEP	AP 203 E1/E2, AP 214	✓	✓	
ISO 16739	IFC	IFC2x Editions 2 and 3	✓		
PTC	Creo Elements/Pro	V18.0 to Wildfire 5	✓	✓	✓
SIEMENS PLM	JT	Up to 9.1	✓	✓	
SIEMENS PLM	NX	Up to NX6	✓	✓	✓
SIEMENS PLM	I-DEAS NX	Up to 13.x (NX5), NX(6)	✓	✓	✓
SIEMENS PLM	Parasolid	Up to 23	✓	✓	
SIEMENS PLM	Solid Edge	19, 20, ST	✓	✓	

Table 5: A possible input format for a PDF Generator 3D. Note that Tess., B-Rep, and PMI stand for Tessellated geometry, Boundary Representation, and 'Product Manufacturing Information (ProSTEP, 2011)

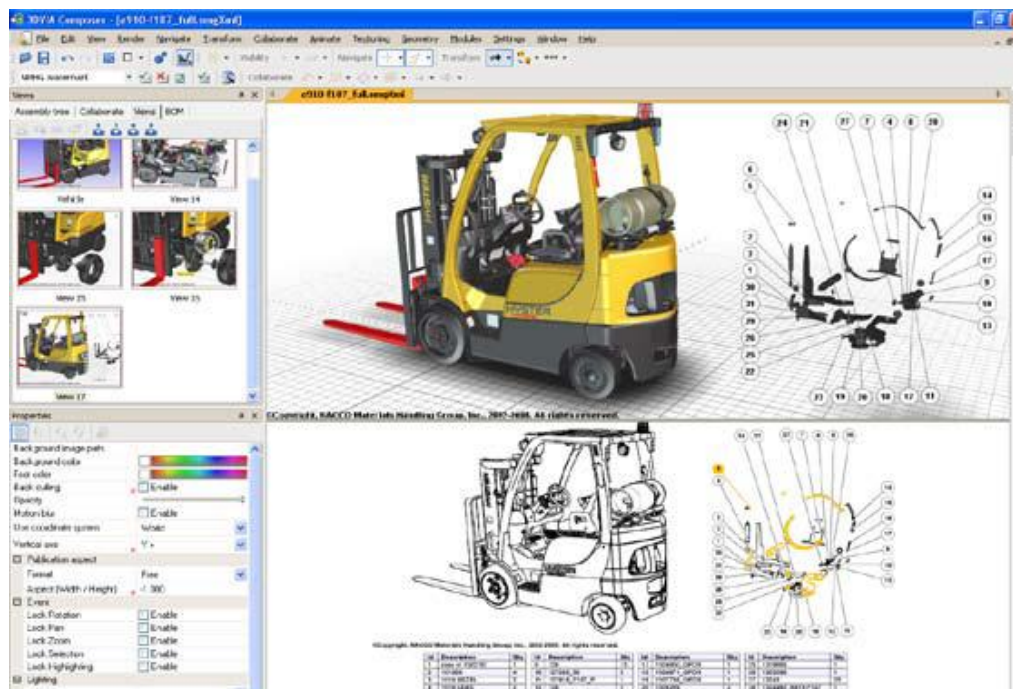

Figure 26: An example of a 3dvia viewer screen shot (DassaultSystem, 2011a)

2. *3dvia Composer*: This application module is developed by 3dvia which is the brand under Dassault systems. It is a typical desktop application that can be used on any standard PC for creating neutral document package from 3D data, including a right management option to set a certain level of access for each user. Its structure is based on lightweight, open XML-based architecture. It also offers BOM and PLM integration via XML interchange. The

ultimate objective is to create a document package of 3D information to allow end-users throughout the product lifecycle to utilize it without any CAD system access, training or knowledge required (DassaultSystem, 2011a).

All major native CAD file input formats including CATIA V5 can be understood and converted into 3DVIA Composer internal formats which are in the Composer's lightweight XML-based file format with capabilities to store native geometry data with a high degree of accuracy. The file format can contain 3D product structure, parts geometry and associated PLM data including 3D Annotations and Dimensions, 3D Exploded Views, 3D Real Time Animations, and 3D Dynamic Cutting Planes. The output file format will be neutral and standard, such as PDF, Microsoft Office, HTML and more, which allows users to integrate the file to their existing documents (DassaultSystem, 2011a).

- **Working procedure:** The 3DVIA Composer imports (via 'drag and drop') any common native CAD file such as CATIA V4, CATIA V5, SolidWorks, Pro / Engineer®, STEP, and XML. Then, the 3D CAD file will be translated into an internal lightweight format file while associates back to the original data, so any design changes are able to be updated without loss or need for rework. The internal format file can be viewed dynamically and interactively via 3dvia Player, which offers the same illustration as done by the file native CAD system in order to provide complete product information. After that, the converted file is optionally merged to PDM, ERP, other system data or exiting documents before generating an output document in the form of Microsoft Office, PDF or some other standard file formats that can be viewed by computer inaccessible users such as shop-floor people (DassaultSystem, 2011a).

There are two kinds of output files. First, an internal lightweight format file can be viewed by 3dvia Player freeware or 3dvia Player Pro which can be used to view the file dynamically. The other is a file under Microsoft Office, PDF or some other standard formats that can be viewed statically by using Microsoft Office, PDF reader or some other common readers respectively. See Figure 26 for an example of a 3dvia viewer screen shot (DassaultSystem, 2011a).

Appendix D.2: Data exchange formats

- **STEP**
 - **Overview and history:** The Standard for the Exchange of Product Model Data or STEP is an ISO standard format first released in 1994, known formally as ISO 10303 for computer-interpretable representation and exchange of product and manufacturing information purposes, (SC4ONLINE, 2011; STEP-Tool, 2011; Wikipedia, 2011b; Lindkvist, 2009). The primary aim was that STEP should be a completed and independent information model. However, due to its complexity, it was divided into several small modules to be developed individually. These small parts (several hundred) are grouped into Environments, Integrated Data Model, and Top parts (Wikipedia, 2011b). The STEP parts can be divided into Description Methods, Information Models, Application Protocols, Implementation Methods, and Conformance Tools (Wikipedia, 2011b; STEP-

Tool, 2011). Due to many elements in STEP, Application Protocols or AP under Top parts is a specific application and industrial focus that is most related to a user.

- **Characteristics of the format:** STEP is continuously developed, a neutral 3D data exchange format between CAD, PDM, and CAx systems. Its ultimate purpose is to provide product data description interchanging throughout the entire product lifecycle in various industries including automotive, aerospace, ship, etc (STEP-Tool, 2011; Wikipedia, 2011b). The strong point of STEP is the ability to exchange product data as solid models and assemblies of solid models even better than IGES. In addition, STEP organizes a forum for the CAD vendors to discuss and provide feedback for continuous improvements (STEP-Tool, 2011). However, there are many sub-parts in this standard and only small parts are related to an information exchange (Lindkvist, 2009). A free STEP viewer, for example, IDA-STEP.
- **Engineering data model:** STEP AP is the content to be discussed since it is most associated with users. The STEP APs can be categorized into the three main areas of design, manufacturing and lifecycle support. Each has its own sub-groups. The group that is related to the context most is Mechanical, which consists of the following APs (Wikipedia, 2011b).
 - *AP 201*, Explicit draughting. Simple 2D drawing geometry related to a product. No association, no assembly hierarchy.
 - *AP 202*, Associative draughting. 2D/3D drawing with association, but no product structure
 - *AP 203*, Configuration controlled 3D designs of mechanical parts and assemblies
 - *AP 204*, Mechanical design using boundary representation
 - *AP 207*, Sheet metal-die planning and design
 - *AP 209*, Composite and metallic structural analysis and related design
 - *AP 214*, Core data for automotive mechanical design processes
 - *AP 235*, Materials information for the design and verification of products
 - *AP 236*, Furniture product data and project data
 - *AP 242*, Managed model based 3D engineering (under development)

It is obvious that Configuration-controlled 3D designs of mechanical parts and assemblies of AP 203 are in the area of 3D model geometrical exchange. Seven types of shape representation are provided in the first edition of this AP - entities of advanced boundary-representation (B-rep) shape representation, edge based wireframe shape representation, faceted B-rep shape representation, geometrically bounded surface shape representation, geometrically bounded wireframe shape representation, manifold surface shape representation, and shell based wireframe shape representation. The latest version of AP 203 is Edition 2. The additional representation from the previous version is entities of constructive solid geometry representation which supports GD&T and geometric validation properties presentation when it works with manifold surface shape representation entities (Briggs and Hendrix, 2006; PDES, 1998).

- **JT**

- **Overview and history:** JT or Jupiter is the most used 3D data format for file sharing and collaboration developed and used by Siemens PLM Software (such as Teamcenter and PTC Windchill). Its most compatible CAD systems are NX and ProEngineer since they belong to Siemens. JT was originally the Direct Model toolkit of Engineering Animation, Inc. and Hewlett Packard. After that, it was purchased by UGS, which was acquired by Siemens AG later. Finally, the Siemens PLM software was introduced. JT has been approved to become an ISO Publicly Available Specification (PAS) in 2009 by ISO (Wikipedia, 2011c).

- **Characteristics of the format:** JT is commonly utilized especially among many large end-users for exchanging CAD data and product visualization which is viewing and manipulating of 3D models, technical drawings and other associated documents. It is known as a lightweight exchanging format (~1-10% of the size of a CAD file) which enhances the online global collaboration both inside and outside a company (Siemens, 2011; Wikipedia, 2011c). According to Siemens, some outstanding benefits for the format are its high performance with small size of format for 3D data, its potential to carry large assembly and model information completely, and its neutral format supported by several major MCAD applications (Siemens, 2011). The latest version of JT is Version 9.5 (AutomotiveIT-International, 2011). JT2Go is an example of a JT free viewer.

- **Engineering data model:** It has potential to represent several kinds of data. Those types include exact boundary representation surfaces which is a rich size or an exact data (NURBS), approximate (faceted) data which is a smaller size, attributes, metadata, product structure, geometry, PMI, multiple tessellations, and level-of-detail (LOD) generation either originated from a CAD system or transited from a PDM system. Data models that are capable of being represented by JT are listed below (Siemens, 2011; Wikipedia, 2011c).

- Product Structure, including assembly, part, and instance
- Facet, including polygon and polygon set.
- Lighting, including light set, point light, and infinite light.
- Textures
- Precise Geometry and Topology, including point, curve, surface, face, loop, edge, and vertex.
- B-rep, including both JT B-rep or XT B-rep (Parasolid) format. Generally, it is exact 3D geometry.
- Geometry Primitives, including box, cylinder, pyramid, and sphere.
- PMI representing GD&T and 3D annotations.
- Attributes and Properties, including string, integer, float, date, and layers.
- Metadata, including property filters, transforms, and bounding box definitions.

- **IGES**

- **Overview and history:** IGES or Initial Graphic Exchange for Specification began to be developed in 1979 by a group of CAD user vendors, with the assisting of the National Bureau of Standards (NIST) and the U.S. Department of Defense (DoD). It is the first national standard for CAD data exchange. However, after STEP had been released,

people had no interest in developing IGES anymore. Its last version is Version 5.3 in 1996 (Lindkvist, 2009).

- **Characteristics of the format:** Even IGES is an old format; it has been commonly utilized as a standard for geometrical data exchange which is applicable to most CAD and CAX software (Lindkvist, 2009). A free viewer of the format is such as IGS Viewer 2.3.
- **Engineering data model:** It defines several different entities, solid primitives and so on. However, the basic unit of the file is described in terms of entity, which is mainly categorized into geometric and non-geometric information (NIST, 2002; Lindkvist, 2009).
 - *Geometry entities:* They represent the geometrical information or the definition of the physical shape which could include curves, points, relations, solids, and surfaces, for example.
 - *Non-geometry:* There are several types of entities but they typically support viewing perspectives, annotation, a general note, witness line and dimensioning, which are applicable to drawings and also provide particular attributes for individual or groups of entities along with their definitions and instances, which may locate in another file. The general entities for attribute could be property and associativity entities.
- **U3D** (ecma International, 2007; Wikipedia, 2011d)
- **Overview and history:** U3D is a format for a computer graphical data exchange. It was invented by 3D Industry Forum, which is participated in by many organizations and companies from various industries. Examples include Intel, Adobe Systems, and Boeing. It is aimed to be a universal exchange format for all kinds of data. It is the international standard within the framework of ISO IS 32000.
- **Characteristics of the format:** It is the format that is used by diverse industries. Its format size is compressed. The native format is supported by 3D data in the U3D format and PDF format could be read by using Acrobat Reader Version 7 or later. Currently, there are 4 versions of the format. The latest was released in 2007. It can be viewed by using general Adobe Reader, for instance.
- **Engineering data model:** The format consists of four editions. The first edition has the capability to carry vertex based geometry, color, textures, lighting, bones, and transform based animation. The second exists to correct errors in the first version. The third edition continues to correct the faults and also includes the concept of vendor specified blocks such as the RHAdobeMesh block. Adobe Acrobat and Reader 8.1 can also read this data. Finally, the fourth version supports definitions of curved surfaces, higher order primitives.

Appendix E: Analysis from the Pugh matrix

Appendix E.1: The Pugh matrix of the strategy selection.

Criteria	Alternatives	
	Strategy 1	Strategy 2
Possible to solve information redundancy problems	+	Datum
More tightly integration between CATIA and PLM	+	
Possible to solve information management and availability problems	+	
Possible to fix CATIA accessibility and availability problems	+	
Provide neutral 3D CAD data exchange format	0	
Provide internal viewer application	0	
Provide standards for notes on a 2D drawing	0	
Possible to preserve Autoliv's super 2D drawing contents	0	
Sum +	+4	
Sum -	0	
Net Value	+4	0
Ranking	1	2
Selection	Yes	No

Appendix E.2: The first Pugh matrix is employed as a selection matrix for the 3D CAD data exchange format.

Criterion	Weight	Alternatives			
		JT	STEP AP 203	IGES	U3D
Compression size	1	+	Datum	0	+
Completeness	3	+		-	0
Usability of file exchanging	2	-		-	-
Generalization and Standardization	3	0		0	-
Continuous improvement	1	0		-	0
Sum +	n/a	+4		0	+1
Sum -		-2	-6	-5	
Net Value		+2	0	-6	-4
Ranking		2	0	4	3
New datum for the 2nd matrix		Yes	No	No	No

Appendix E.3: The second Pugh matrix is employed as a selection matrix for the 3D CAD data exchange format.

Criterion	Weight	Alternatives				
		STEP AP 203	JT	IGES	U3D	
Compression size	1	-	Datum	-	0	
Completeness	3	-		-	-	
Usability of file exchanging	2	+		0	0	
Generalization and Standardization	3	0		0	-	
Continuous improvement	1	0		-	0	
Sum +	n/a	+2		0	0	
Sum -		-4		-5	-6	
Net Value		-2		0	-5	-6
Ranking		2		1	3	4
Selection		Optional		Yes	No	No